

Operating Instructions

Features

1 Space-saving ice maker*

Ice maker and bin are located on the door creating more usable storage space.

2 Showcase LED lighting

LED lighting is positioned throughout the interior to spotlight areas in the refrigerator. LEDs are located under the fresh food door to light the freezer when opened.

3 Drop-down tray*

Allows for extra door storage when you need it and tucks away when you don't.

4 Full-width temperature controlled drawer

Adjustable temperature control bin that can accommodate larger items.

5 Dairy bin

Separate compartment for your items.

6 Ice bin/Ice maker*

Ice maker with ice storage bins.

7 QuickSpace shelf*

Functions as a normal full-sized shelf when needed and easily slides back to store tall items below.

8 Spillproof shelves

Designed to capture your spills for easier clean up.

9 Anti-slip Mat

Liner that captures spills. keeps containers from shifting when the door is opened and is easily removable for cleaning.

10 Removable door bin

Can be removed for those with a wall limiting the door opening.

11 Climate zone bin

Separate bins for produce storage.

12 Water filter

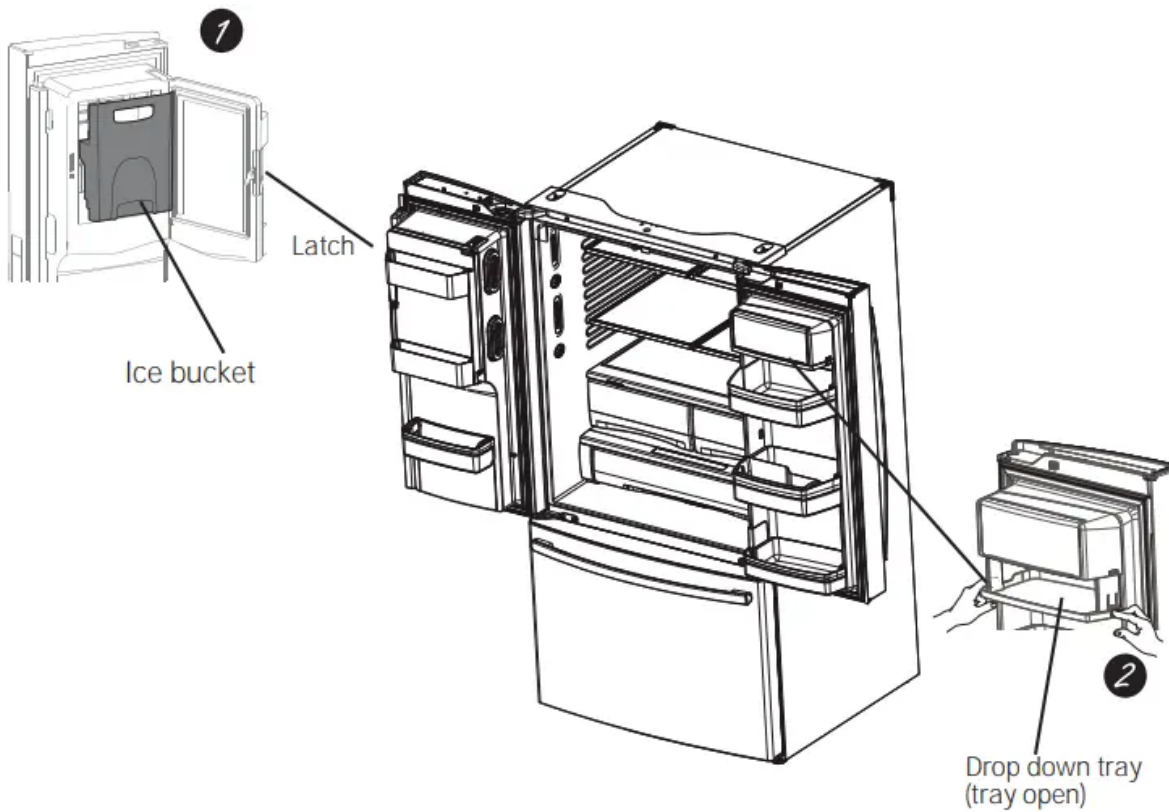

Ice bucket

1 Door ice bin*

- 1. Open left fresh food door. ff
- 2. Pull down latch to release bin y door.
- 3. Using handhold lift ice bucket up and out to clear locators in H i bottom of bin.
- 4. To replace the ice bucket. set it on the guide brackets and push until the ice bucket seats properly.
- 5. If bucket cannot be replaced. rotate the Ice Bucket Fork 1/4 turn clockwise.

2 Drop down dairy bin*

1. Open right fresh food
2. Depress both buttons on lower sides and bin will drop down.
3. Reverse to reinstall.

3 Ice/water filter

Remove filter/bypass plug

Push the indent on the cover and pull open filter door fully. Rotate the filter/bypass plug as far as it will go and pull the filter/oypass plug toward you to remove.

Installing the filter cartridge

Push the new filter/bypass plug straight in aligning the lugs with the notches in cabinet and rotate the filter/bypass plug into the recess in the cabinet. Make sure the front of the filter is toward the interior of the refrigerator.

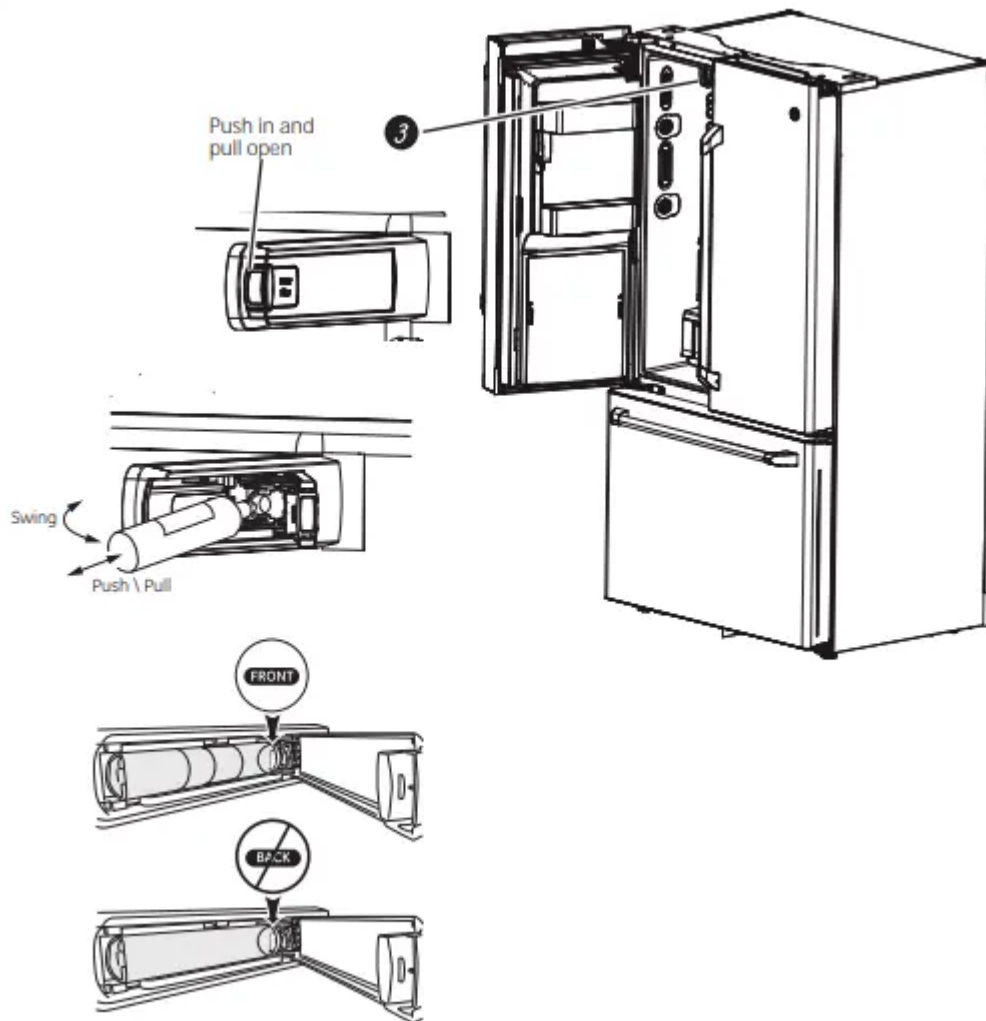

About the controls with temperature settings.

PFE28,PYE22P Control Style A, LCD External Control

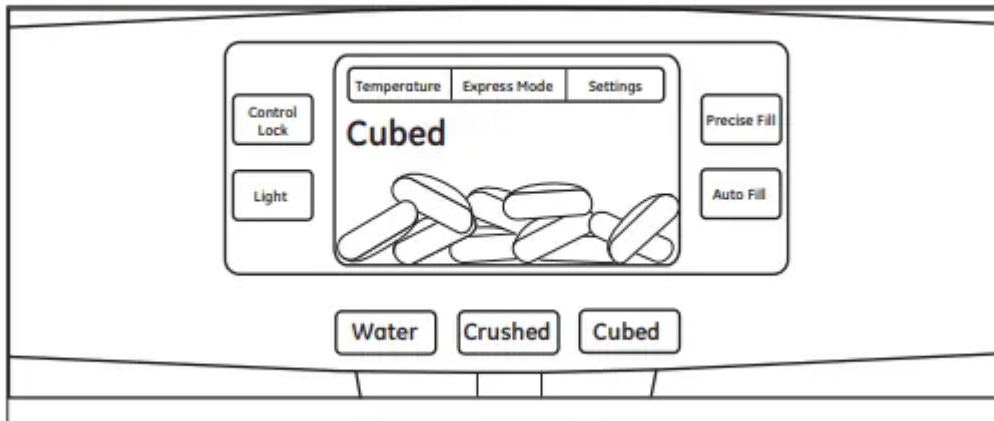

GFE28, GFE26, DFE28, GYE22 Control Style B, External Control

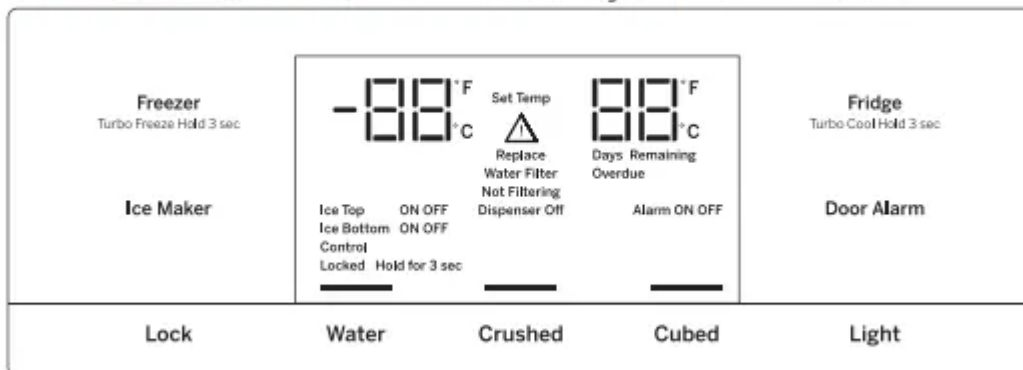

GNE29, PWE23 Control Style C, Internal Control

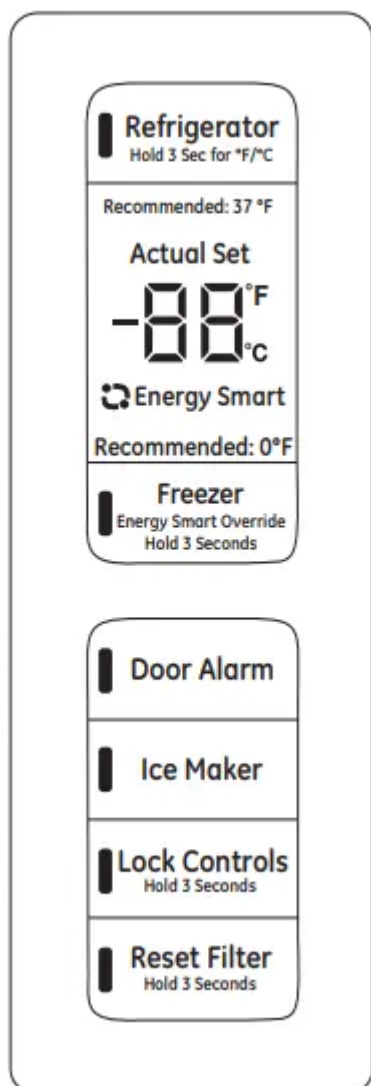

NOTE: The refrigerator is shipped with protective film covering the temperature controls. If this film was not removed during installation, remove it now.

The temperature controls are preset in the factory at 37°F for the refrigerator compartment and 0°F for the freezer compartment. Allow 24 hours for the temperature to stabilize to the preset recommended settings.

The temperature controls can display both the SET temperature as well as the actual temperature in the refrigerator and freezer. The actual temperature may vary slightly from the SET temperature based on usage and operating environment.

Changing the Temperature for Control Style A

To Change the Refrigerator Temperature:

Access By: Temperature Button **Temperature**

Activate By: Below the word “Refrigerator”, use the arrows to select the desired temperature. Press DONE when finished to return to HOME screen.

To Change the Freezer Temperature:

Access By: Temperature Button **Temperature**

Activate By: Below the word “Freezer”, use the arrows to select the desired temperature. Press DONE when finished to return to HOME screen.

To turn OFF cooling system, access SETTINGS from the HOME screen. Page over and tap COOLING SYSTEM ON. Press DONE to return to HOME screen.

To turn ON cooling system, access SETTINGS from the HOME screen. Page over and tap COOLING SYSTEM OFF. Press DONE to return to HOME screen.

Turning the cooling system off stops the cooling to refrigerator, but it does not shut off the electrical power

Changing the Temperature for Control Style B

To change the temperature, press and release the Freezer or Fridge pad. The display will show the set temperature. To change the temperature, press either the Freezer or Fridge pad until the desired temperature is displayed.

To turn OFF cooling system, press and hold Fridge and Ice Maker simultaneously for 3 seconds. When the cooling system is OFF the display should read OFF.

Changing Temp. for Control Style C

Temperature Display is located on inside of left-hand refrigerator door. To change the temperature, press and release the REFRIGERATOR or FREEZER pad. The ACTUAL TEMP light will come on and the display will show the actual temperature. To change the temperature, tap either the REFRIGERATOR or FREEZER pad until the desired temperature is displayed.

To turn OFF cooling system, press and hold the REFRIGERATOR and FREEZER pads simultaneously for 3 seconds. When the cooling system is OFF the display should read OFF.

To turn ON cooling system, press either REFRIGERATOR or FREEZER pad. The display will show the preset temperature settings of 37°F for refrigerator and 0°F for freezer. Turning the cooling system off stops the cooling to refrigerator, but it does not shut off the electrical power.

NOTE: For optimal temperature performance, we recommend to avoid placing food items directly at the air flow vents of the fresh food air tower and thus blocking the air flow.



About the controls - features.

Control Style A, External Controls PFE28, PYE22P

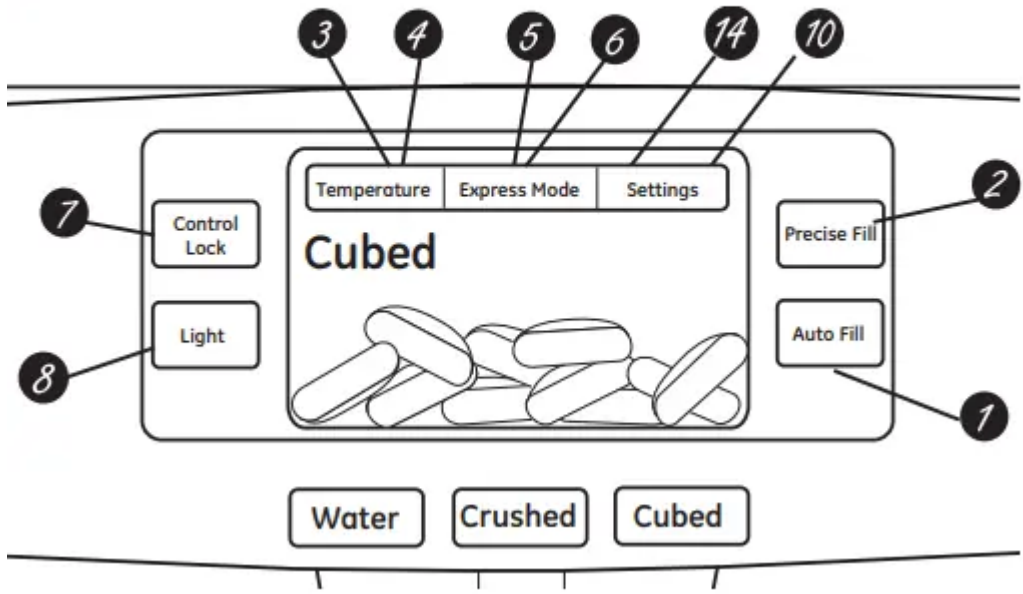

Control Style B, External Controls GFE28, GFE26, DFE28, GYE22

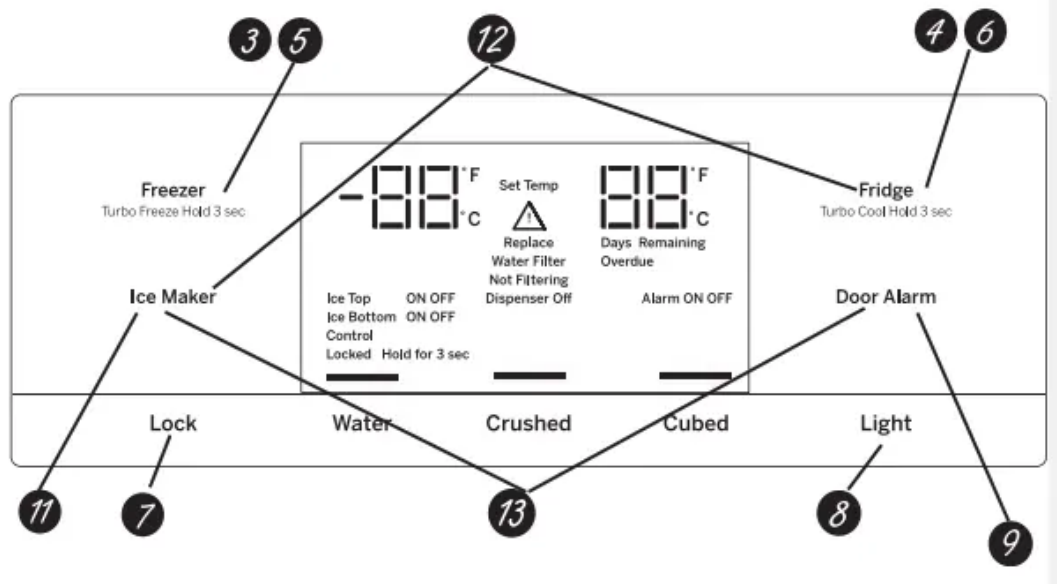

1 Hands-free Autofill*

Hands-free Autofill uses sensors to monitor container height to automatically dispense filtered water without having to activate the paddle.

2 PreciseFill setting*



Precisely dispenses filtered water in accurate measurements in ounces, cups, quarts, or liters using paddle.

3 Refrigerator temp control

Adjust freezer compartment temperature.

4 Fresh food temp control

Adjust fresh food compartment temperature.

5 TurboFreeze™ setting

Activate TurboFreeze to quickly restore freezer temperatures after frequent door openings.

6 TurboCool™ setting

Activate TurboCool to quickly restore fresh food temperature after frequent door openings.

7 Lock controls

Press and hold 3 seconds to lock out ice and water dispenser and all feature and temperature buttons.

8 LED dispenser light

LED lighting that can be turned on/off to light your dispenser.

9 Door Alarm

Sounds to alert when the freezer or fresh food doors have been left open. Press and hold Door Alarm pad and it will toggle the sound between low, high and off.

10 Photo upload*

Insert USB memory stick to upload personal photos to the refrigerator LCD screen. LCD will provide on screen prompts to load and view slideshow. Make sure the photos are in the root directory in your USB.

11 Ice maker setting

Turn your ice makers on/off.

12 Cooling system On/Off

Press and hold Fridge & Ice Maker simultaneously for 3 seconds to turn the cooling system on or off.

13 Metric/English units

Press and hold Ice Maker & door alarm simultaneously for 3 seconds to switch between Metric & English units.

14 Additional settings:

- Photo upload and delete

- Slideshow
- Connected Home ready
- Reset water filter
- Ice maker on/off
- Door alarm
- Sound control
- Cooling system On/Off
- Metric/English units
- Auto fill video tutorial

Controls Style D, Internal Controls GNE29, PWE23

1 Door Alarm

Sounds to alert when the freezer or fresh food doors have been left open.

2 Reset Filter

Hold for 3 seconds after replacing filter.

3 Lock Controls

Press and hold 3 seconds to lock out ice and water dispenser and all feature and temperature buttons.

4 Freezer temp control

Adjust freezer compartment temperature

5 Refrigerator temp control

Adjust fresh food compartment temperature

6 Ice maker setting

Turn your ice maker on/off.

About the dispenser.*

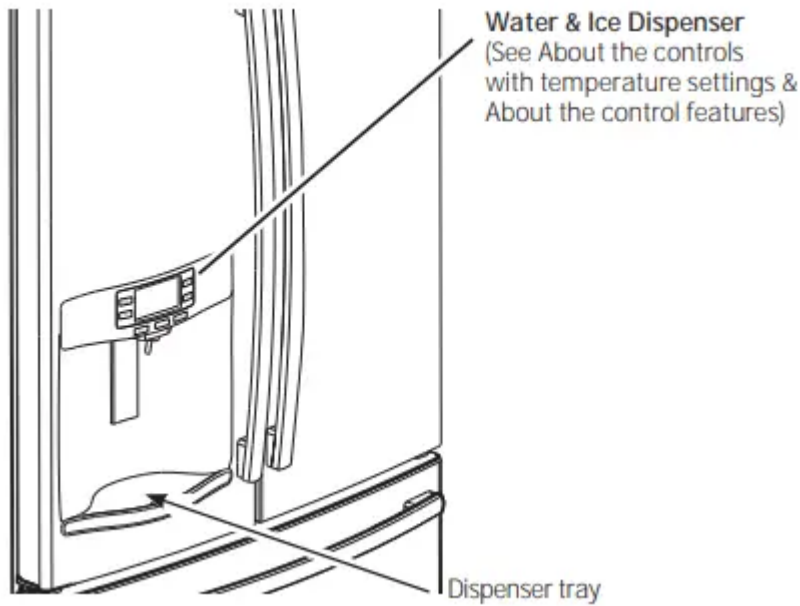

Laceration Hazard

- Never put fingers or any other object into ice crusher discharge opening. Doing so can result in contacting the ice crushing blades and lead to serious injury or amputation
- Use a sturdy glass when dispensing ice. A delicate glass may break and result in personal injury.

If no water is dispensed when the refrigerator is first installed, there may be air in the water line system. Press the dispenser paddle for at least five minutes to remove trapped air from the water line and to fill the water system. To flush out impurities in the water line, throw away the first six full glasses of water.

To remove Dispenser Tray (Type A Only)

- Pull Dispenser Tray out until it stops.
- Locate tab in the center on the bottom and push up.
- Pull Dispenser Tray assembly out.
- Lift metal Dispenser Tray out at center notch to clean.

To remove Dispenser Tray (Type B Only)

- Pull Dispenser Tray out.

To reinstall Dispenser Tray (Type A Only)

- Place the Dispenser Tray cover on top of catch tray and position under the two plastic retainers on either side.
- Center Dispenser tray, and align with center guides.

- Push in until it locks firmly in place.

To reinstall Dispenser Tray (Type B Only)

- Center Dispenser Tray and push in until it snaps in place.

Important Facts About Your Dispenser

- Do not add ice from trays or bags to the door ice maker bucket. It may not crush or dispense.
- Avoid overfilling glass with ice and use of narrow glasses. Backed-up ice can jam the chute or cause the door in the chute to freeze shut. If ice is blocking the chute remove the ice bucket. poke it through with a wooden spoon.
- Beverages and foods should not be quick-chilled in the door ice maker bin. Cans, bottles or food packages in the storage drawer may cause the ice maker or auger to jam.
- To keep dispensed ice from missing the glass, put the glass close to, but not touching, the dispenser opening.
- Some crushed ice may be dispensed even though you selected CUBED ICE. This happens occasionally when a few cubes accidentally get directed to the crusher.
- After crushed ice is dispensed, some water may drip from the chute.
- Sometimes a small mound of snow will form on the door in the ice chute. This condition is normal and usually occurs when you have dispensed crushed ice repeatedly. The snow will eventually evaporate.

To Use the Internal Water Dispenser*

The water dispenser is located on the left wall inside the refrigerator compartment.

To dispense water:

1. Hold the glass against the recess.
2. Push the water dispenser button.
3. Hold the glass underneath the dispenser for 2-3 seconds after releasing the dispenser button. Water may continue to dispense after the button is released.

If no water is dispensed when the refrigerator is first installed, there may be air in the water line system. Press the dispenser button for at least 5 minutes to remove trapped air from the water line and to fill the water system. During this process, the dispenser noise may be loud as the air is purged from the water line system. To flush out impurities in the water line, throw away the first 6 glassfuls of water.

NOTE: To avoid water deposits, the dispenser should be cleaned periodically by wiping with a clean cloth or sponge.

AUTOFILL*

To Use HANDS FREE AUTOFILL

- Center container on Recess Dispenser Tray as far back as possible without activating paddle and remove hand from container
- Press AUTOFILL

To Stop AUTOFILL

- Press AUTOFILL to stop.

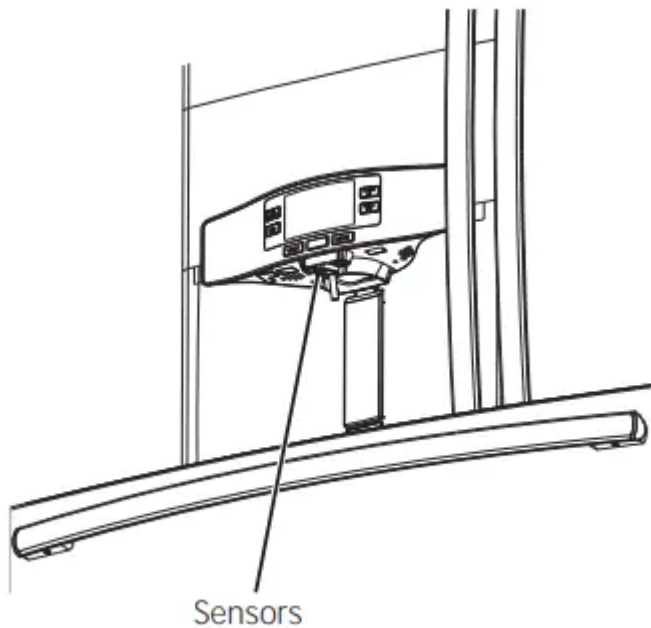

Important Facts about AUTOFILL

- For optimum results. use a uniform container between 4-8" (10-20 cm) tall and 2-6" wide.
- Container shape, fill level and functionality may vary on containers taller than 8"
- Container volumes may vary, if error message "Container Not Found" is given, try a different container
- AUTOFILL will time out.
- Handles, straws, and garnishes on the rim of the container may cause overflowing or variation in fill volumes.
- Splashing may occur depending on the location of the container, water flow rate, container shape, and ice cubes.
- Keep sensors clean with a clean damp cloth, and do not spray liquid or cleaners directly on sensors
- AUTOFILL works best with household water pressure of 60 to 100 psi (414 to 689 kPa).

About the fresh food storage options.

Rearranging the Shelves

Shelves in the refrigerator compartment are adjustable.

To remove:

1. Remove all items from the shelf.
2. Tilt the shelf up at the front.
3. Lift the shelf up at the back and bring the shelf out

To replace:

1. While tilting the shelf up, insert the top hook at the back of the shelf in a slot on the track.
2. Lower the front of the shelf until the bottom of the shelf locks into place

Spillproof Shelves

Spillproof shelves have special edges to help prevent spills from dripping to lower shelves.

Quick Space Shelf *

This shelf splits in half and slides under itself for storage of tall items on the shelf below.

This shelf can be removed and replaced or relocated (just like spillproof shelves)

NOTE: The back half of the Quick Space Shelf is not adjustable.

Non-Adjustable Dairy Bin*

To remove: Lift the dairy bin straight up, then pull out.

To replace: Engage the bin in the molded door supports and push down. The bin will lock in place.

See page 33.

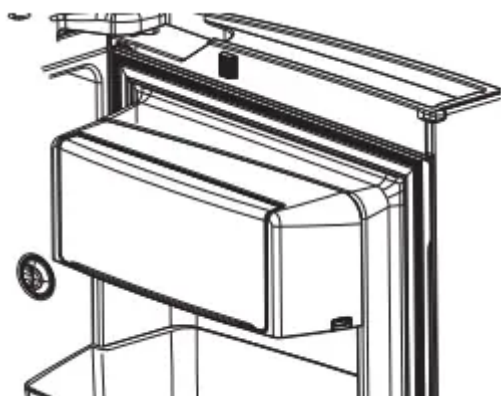

Adjustable Bins on the Door

Adjustable bins can easily be carried from refrigerator to work area.

To remove: Lift bin straight up, then pull out.

To replace or relocate: Slide in the bin just above the molded door supports, and push down. The bin will lock in place. See page 33.

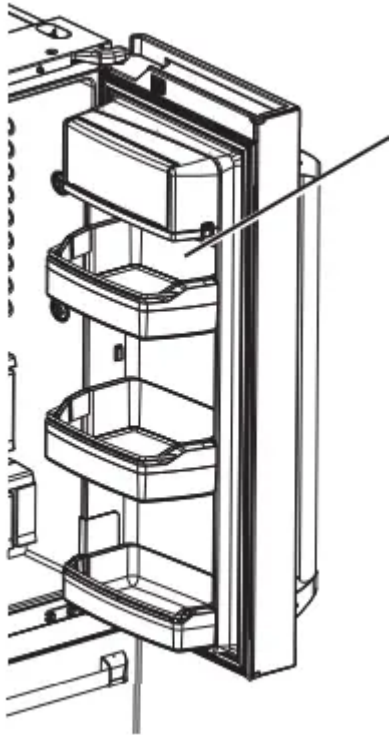

Drop down tray * (tray open)

1. Open right fresh food door
2. Depress both buttons on lower sides of bin and bin will drop down.
3. Reverse to reinstall.



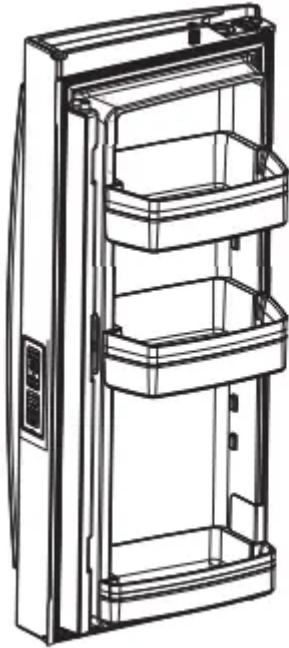

Non-Dispense Models (Left Hand Door)

Non-Adjustable Bins on the Door (Dispenser Models - Left Hand Door)

To remove: Lift the bin straight up, then pull out.

To replace: Engage the bin in the molded supports on the door and push down. It will lock in place. The ice maker door bins are not interchangeable, note the location upon removal and replace the bin in its proper location.

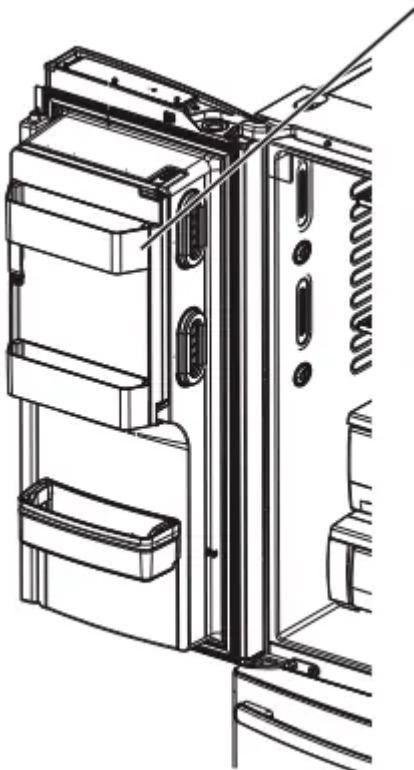

About the climate zone and temperature controlled drawer.

ClimateZone

Keep fruits and vegetables organized in separate compartments for easy access.

Excess water that may accumulate in the bottom of the drawers or under the drawers should be wiped dry.

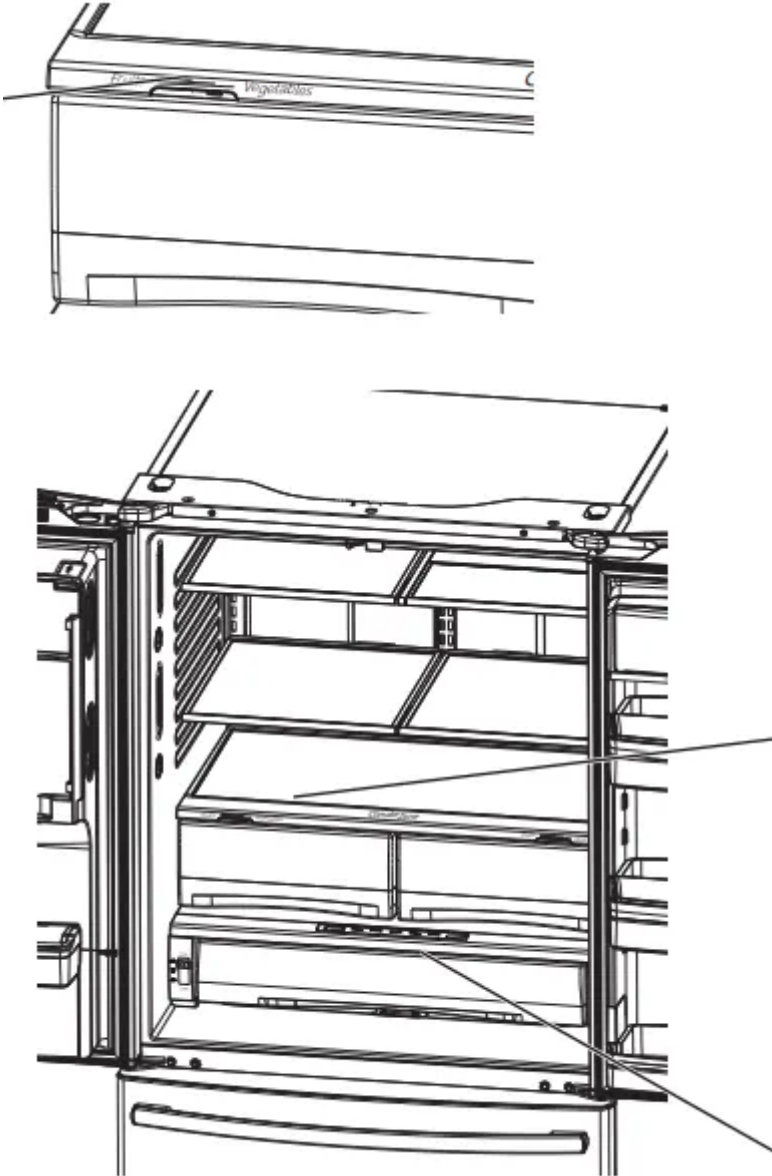

Note: Temperatures indicate the appropriate temperatures for the food and actual temperatures may vary based on normal operation and other factors such as door openings and fresh food set point.

Temperature Controlled Drawer*

The Temperature Controlled Drawer is a full-width drawer with adjustable temperature control. This drawer can be used for large miscellaneous items.

To change setting, press select button.

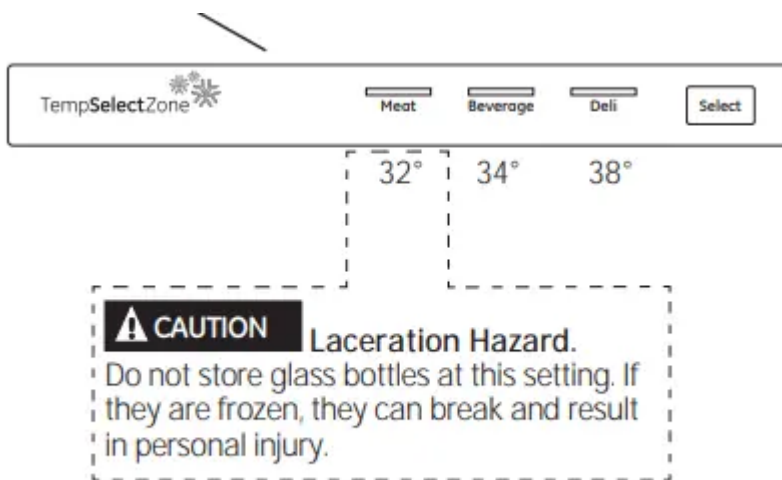

How to Remove and Replace Drawer

To remove:

1. Pull the drawer out to the stop position.
2. Lift the front of the drawer up and out.

To replace:

1. Pull left and right slides until fully extended.
2. Place drawer back in first and rotate drawer front down to seat on slide.
3. Push the drawer in to closed position.

How to Remove and Replace Drawer Divider*

To remove:

1. Pull the drawer out to the stop position.
2. Raise the front side of the divider to unhook it from the rear wall of the drawer.

To replace:

1. Hook the back of the divider over the rear wall of the drawer.
2. Push the divider down.

CARE AND CLEANING

Cleaning the Outside

The stainless steel panels, door handles and trim.

The stainless steel doors and door handles (on some models) can be cleaned with a commercially available stainless steel cleaner. Cleaners with oxalic acid such as Bar Keepers Friend Soft Cleanser will remove surface rust, tarnish and small blemishes. Use only

a liquid cleanser free of grit and rub in the direction of the brush lines with a damp soft sponge. Do not use appliance wax or polish on the stainless steel.

Silver-accented plastic parts.

Wash parts with soap or other mild detergents. Wipe clean with a sponge, damp cloth or paper towel. Do not use scouring pads, powdered cleaners, bleach or cleaners containing bleach because these products can scratch and weaken the paint finish.

Should spill tray need cleaning use lime remover.

Cleaning the Inside

To help prevent odors. leave an open box of baking soda in the refrigerator and freezer compartments.

Unplug the refrigerator before cleaning.

If this is not practical, wring excess moisture out of sponge or cloth when cleaning around switches, lights or controls.

Use an appliance wax polish on the inside surface between the doors.

Use warm water and baking soda solution—about a tablespoon (15 ml) of baking soda to a quart (1 liter) of water. This both cleans and neutralizes odors. Rinse and wipe dry.

To clean the inside metal panel*. open the outer door using the Door in Door Latch. Clean the panel with a mild detergent and then wipe dry with a soft cloth. Do not use any stainless steel cleaner on the panel as it may damage the surrounding plastic.

CAUTION Do not clean glass shelves or covers with warm water when they are cold. Glass shelves and covers may break if exposed to sudden temperature changes or impact such as bumping or dropping. Tempered glass is designed to shatter into many small pieces if it breaks. Do not wash any plastic refrigerator parts in the dishwasher.

Behind the Refrigerator

Be careful when moving the refrigerator away from the wall. All types of floor coverings can be damaged, particularly cushioned coverings and those with embossed surfaces.

Raise the leveling legs located at the bottom front of the refrigerator.

Pull the refrigerator straight out and return it to position by pushing it straight in. Moving the refrigerator in a side direction may result in damage to the floor covering or refrigerator.

Lower the leveling legs until they touch the floor.

When pushing the refrigerator back, make sure you don't roll over the power cord or water supply line.

Preparing for Vacation

For long vacations or absences, remove food and unplug the refrigerator. Clean the interior with a baking soda solution of one tablespoon (15 ml) of baking soda to one quart (1 liter) of water. Leave the doors open.

If the temperature can drop below freezing, have a qualified service technician drain the water supply system to prevent serious property damage due to flooding.

- 1. Turn refrigerator off or unplug the refrigerator.
- 2. Empty ice bucket
- 3. Turn water supply off

If you cut the water supply off, turn off the ice maker.

Upon returning from vacation:

- 1. Replace the water filter.
- 2. Run 2 gallons (7.57 liters) of water through the cold water dispenser (about 5 minutes) to flush the system.

Preparing to Move

Secure all loose items such as shelves and drawers by taping them securely in place to prevent damage.

When using a hand truck to move the refrigerator, do not rest the front or back of the refrigerator against the hand truck. This could damage the refrigerator.

Handle only from the sides of the refrigerator.

Be sure the refrigerator stays in an upright position during moving.

Refrigerator the Lights

Refrigerator Lights (LEDs)

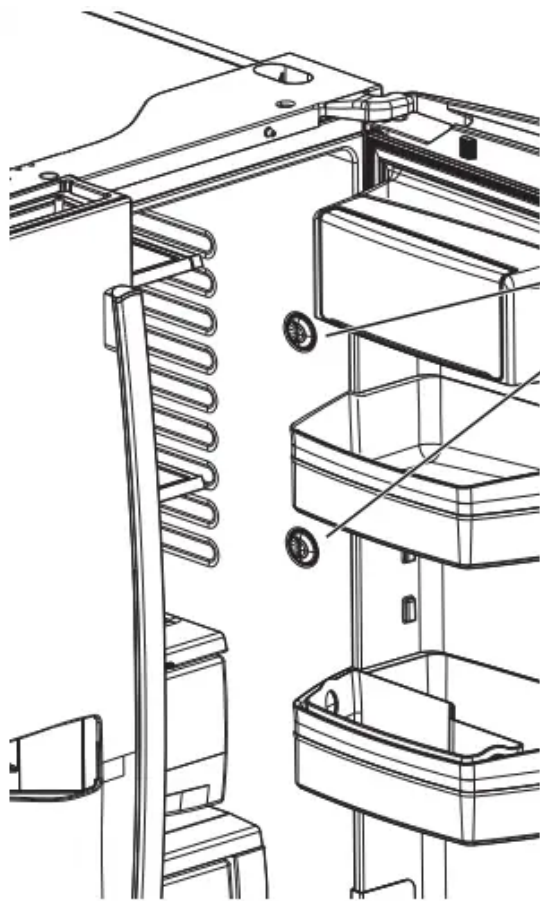

There is LED lighting in fresh food compartment and on the bottom of the fresh food doors to light the freezer compartment.*

An authorized technician will need to replace the LED light.

If this assembly needs to be replaced, call GE Service at 1.800.432.2737 in the United States or 1.800.561.3344 in Canada.

Installation Instructions

INSTALLING THE REFRIGERATOR

REMOVE THE FRESH FOOD DOOR HANDLE

Handle Design varies based on models, however Installation is same.

Stainless steel and plastic handles:

A Loosen the set screws with the 1/8" Allen wrench and remove the handle.

NOTE: If the handle mounting fasteners need to be tightened or removed, use a 1/4" Allen wrench.

REMOVE THE FREEZER DOOR HANDLE

Handle Design varies based on models, however Installation is same.

Stainless steel and plastic handles:

A Loosen the set screws with the 1/8" Allen wrench and remove the handle.

NOTE: If the handle mounting fasteners need to be tightened or removed, use a 1/4" Allen wrench.

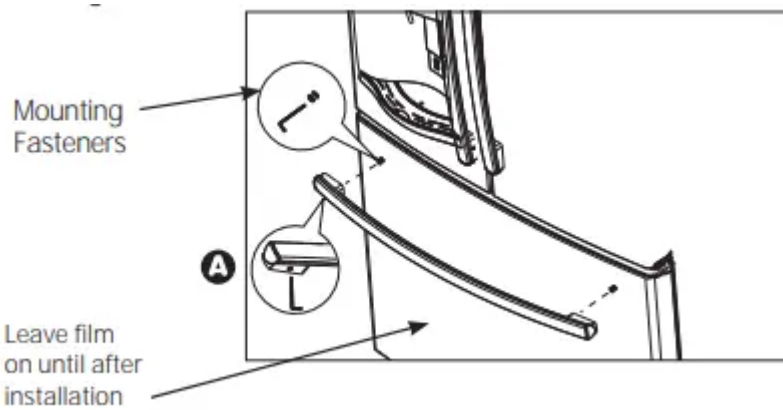

REMOVING FRENCH DOORS

WARNING

Follow all steps when reversing the door swing. Failure to follow these instructions, leaving off parts, or overtightening screws, can lead to the door falling off and result in injury and property damage.

A Securely tape the door shut with masking tape or have a second person support the door.

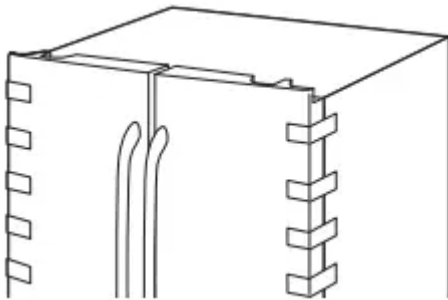

B Start with left-hand door first: Remove the hinge cover on top of the left refrigerator door by removing all hex screws and pulling it up. Do the same for the right-hand door and the middle cover.

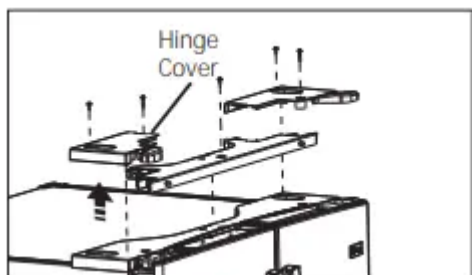

C Disconnect electrical connectors coming from each door located under the hinge covers. Remove the 1/4" hex head screw to disconnect the ground wire from the hinge. Remove the 1/4" hex head screw to remove the strain relief from the water line.

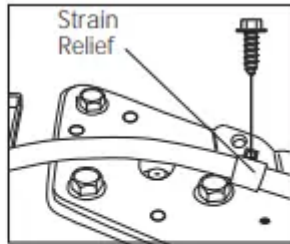
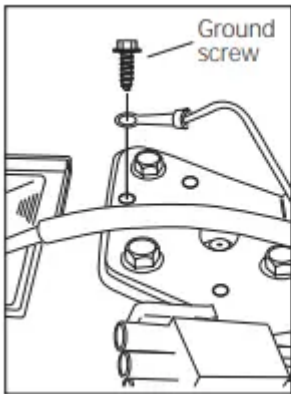
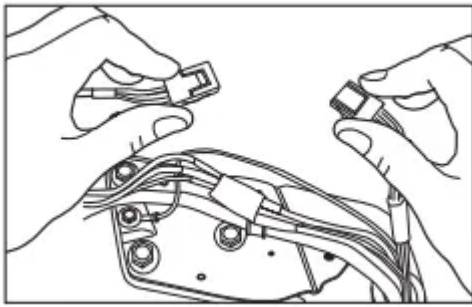

D Disconnect the water line from the back of the unit by pressing down on the dark grey collar while pulling up on the water line. Pull water line through case conduit from the top to free the line for door removal. The water line is more than 4' long and may need to be taped to Door for accessibility when reinstalling.

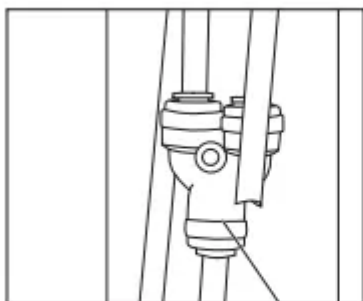

Y or Straight Connector

E Using a 3/8" socket ratchet/driver, remove the screws securing the top hinge to the cabinet, then lift the hinge straight up to free the hinge pin from the location in the top of the door.

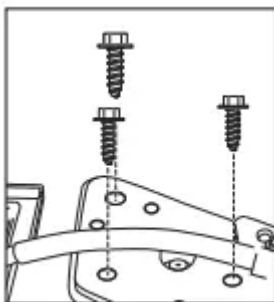

CAUTION Lifting Hazard

Single person lift could cause injury. Use assistance when handling, moving or lifting the doors.

NOTE: when removing door, to prevent damage to door and electronics, carefully place the door in a proper location.

NOTE: The lower door hinge pin and hinge are keyed and must be matched correctly for the door to self close properly. Please follow the directions carefully.

F Remove the tape and keeping the door as straight as possible, open the door to 90° then lift straight up to remove it.

REMOVE OPPOSITE DOOR

Follow the same procedure on the opposite door. There are no water lines on the opposite side.

REMOVE CENTER HINGE (if necessary)

Remove the 3/8" screws securing the center hinge to the cabinet.

Use T20 driver to remove outboard screw.

REINSTALLING THE REFRIGERATOR DOORS

Reverse steps 1 through 4 to reinstall refrigerator doors, follow details below for critical alignments.

A Reinstall center hinge first and torque the screws to 65 in-lbs (7.34 N-m). With the LH door at 90° to the front of the case, lower the refrigerator door onto the center hinge. Ensure that the door and hinge align correctly.

B Rotate doors closed and make sure moveable center sealing portion of the door aligns with the striker. If the door will not self-close after reinstalling, remove door, turn door upside down, check alignment mark and arrow; (there is an alignment mark on the door closure mechanism. It corresponds to an alignment arrow on the plastic ring. Rotate door closure mechanism to align mark and arrow, reinstall door).Door in Door models do not have the same closure mechanism on the right hand door. You may notice a difference in closure.

If door cannot be installed at 90° follow steps below:

1. Install door at 180° to case front.
2. If space limits opening door to less than 180°, then:

- a) Remove door, carefully turn door upside down.
- b) Check alignment of door closure mechanism shaft on underside of door. The flats on the shaft should correspond to alignment tab on plastic ring or mark on bottom end cap.
- c) If shaft is not aligned to tab/mark, using 5/32" Allen wrench, rotate door closure mechanism shaft counterclockwise for right door and clock- wise for left door. Then align flat with tab/mark.
- d) Install the door at 90°.

Securely tape the door shut with masking tape or have a second person support the door. Reinstall the top hinge and torque the screws to 65 in-lbs (7.34 N-m).

C Be sure to reinstall the ground wire and strain relief to the top hinge.

D Reinstall hinge cover. NOTE: Ensure wires are not pinched or under screw bosses before tightening screws.

REMOVE THE FREEZER DOOR

A Pull the freezer door open to full extension.

B Remove 3 attachment screws, located at the bottom on each side of the freezer door using 3/8" hex socket driver.

C Lift the freezer door to disengage it from the slide mechanism

The door can safely rest on the bottom. Do not rest the door on any other surfaces to avoid scratches.

Push the slide mechanism back completely until it self retracts.

REPLACING THE FREEZER DOOR

A Pull the slide Mechanism to full extension using both hands simultaneously.

B Remove the basket resting on the slides

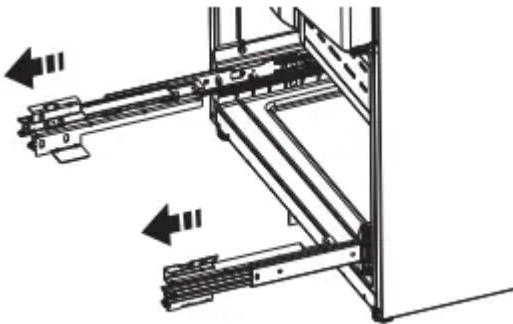

C Lift the freezer door and place it on the slide mechanism

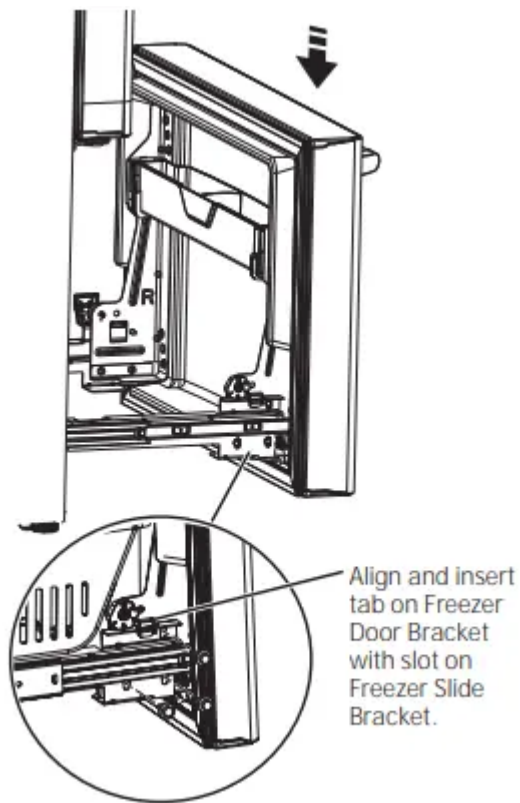

D Replace the attachment screws and torque the screws to 65 in-lb

E For adjusting freezer door gaps, follow the instructions on pg 27.

F Replace the basket

TROUBLESHOOTING TIPS

Normal Operating Conditions.

Newer refrigerators sound different from older refrigerators. Modern refrigerators have more features and use newer technology

Do you hear what I hear? These conditions are normal.

- The new high efficiency compressor may run faster and longer than your old refrigerator and you may hear a high-pitched hum or pulsating sound while it is operating
- You may hear a whooshing sound when the doors close. This is due to pressure equalizing within the refrigerator. a After dispensing ice, a motor will close the ice chute to keep warm room air from entering the ice bucket, maintaining ice at a freezing temperature.
- The hum of the motor closing the ice chute is normal, shortly after dispensing ice.
- You may hear the fans spinning at high speeds. This happens when the refrigerator is first plugged in, when the doors are opened frequently or when a large amount of food is

added to the refrigerator or freezer compartments. The fans are helping to maintain the correct temperatures.

- The fans change speeds in order to provide optimal cooling and energy savings.

CLICKS, POPS, CRACKS and SNAPS

- You may hear cracking or popping sounds when the refrigerator is first plugged in. This happens as the refrigerator cools to the correct temperature.
- The compressor may cause a clicking or chirping sound when attempting to restart (this could take up to 5 minutes).
- Expansion and contraction of cooling coils during and after defrost can cause a cracking or popping sound.
- On models with an ice maker. after an ice making cycle. you may hear the ice cubes dropping into the ice bucket.

WATER SOUNDS

- The flow of refrigerant through the cooling coils may make a gurgling noise like boiling water.
- Water dropping on the defrost heater can cause a sizzling. popping or buzzing sound during the defrost cycle.
- A water dripping noise may occur during the defrost cycle as ice melts from the evaporator and flows into the drain pan.
- Closing the door may cause a gurgling sound due to pressure equalization.

START UP COOLING

It can take up to 24 hours for the refrigerator and freezer temperatures to match the display. During that time refrigerator and freezer door openings should be minimized.

TIPS

- Freezer cools first.
- Refrigerator compartment cools last; it may take several hours after the freezer.
- Turning off ice maker makes both fresh food and freezer food cool faster.

Before you call for service

Water filter indicated as installed incorrectly or a leak is present on LCD screen

- Water filter installed backward or is leaking.
 - Check for leak. If no leak is present. remove filter/bypass plug**. rotate 180° and reinstall.

Water filter indicator light remains lit after replacing filter

- Filter timer has not been reset or filter is installed backward.
 - Internal Dispense models: -Press and hold reset button for 3 seconds
 - External Dispense models: -Remove filter and rotate 180 degrees and reinstall.

Water filter indicator light is not lit

- This is normal. This indicator will turn on to tell you that you need to replace the filter soon.
 - See About the Water Filter for more information.

Handle is loose/handle has a gap.

- Handle needs adjusting
 - See Attach Fresh Food Handle and Attach the Freezer Handle sections for detailed instructions.

Refrigerator beeping

- This is door alarm
 - Turn off or disable with door closed
 - If door open and alarm is sounding. you can only snooze the alarm

Not cooling

- The cooling system is off
 - See About Controls.

Water has poor taste/odor*

- Water dispenser has not been used for a long time
 - Dispense water. until all water in system is replenished.

Water in glass is warm*

- Normal when refrigerator is first installed
 - Wait 24 hours for the refrigerator to completely cool down.
- Water dispenser has not been used for a long time
 - Dispense water. until all water in system is replenished
- Water system has drained
 - Allow several hours for replenished supply to chill

Water dispenser does not work*

- Water supply line turned off or not connected
 - See installing the Water Line
- Water filter clogged or filter/bypass plug not installed
 - Replace filter cartridge or remove filter and install bypass plug**
- Air may be trapped in the water system
 - Press the dispenser arm for at least 5 minutes.
- Water in reservoir is frozen because the controls are set too cold
 - Set the refrigerator control to a warmer setting and wait 24 hours. If the water does not dispense after 24 hours. call for service

Water spurting from dispenser*

- Newly installed filter cartridge
 - Run water from the dispenser for 5 minutes (about 2 gallons)

No water or ice cube production*

- Supply line or shutoff valve is clogged
 - Call a plumber
- Water filter is clogged
 - Replace filter cartridge or remove filter and install bypass plug**
- Filter cartridge not properly installed
 - Remove and reinstall filter cartridge, being certain that it locks in place.
- Ice maker is turned off
 - Check that the ice maker is turned on. See About the Automatic Ice Maker.

Water is leaking from dispenser*

- Air may be present in the water line system, causing water to drip after being dispensed
 - Dispense water for at least 5 minutes to remove air from system

Photos not found*

- Photos not in root directory of USB
 - Make sure the photos are in the root directory in your USB
- Photos not in JPEG format
 - Photos must be in JPEG format

- Camera/PC used with USB cord
 - Must use a USB drive

AUTO FILL under fill/no fill

- Not all containers work with AUTOFILL
 - Try different container
- Container not found
- Unstable container
- Misaligned container
 - See pg. 11

AUTO FILL overfills*

- Not all containers work with AUTO FILL
 - Try different container

PRECISE FILL will not fill container*

- Normal, PRECISE FILL requires use of dispenser paddle
 - For a specific amount of water, select PRECISE FILL to dispense water

Freezer cooling, fresh food not cooling

- Normal, when refrigerator first plugged in or after extended power outage
 - Wait 24 hours for temperature in both compartments to reach selected temperatures.

Ice dispenser opens after closing freezer drawer *

- Normal
 - The ice dispenser door may open after closing freezer door to allow access

Freezer cooling, fresh food not cooling

- Normal, when refrigerator first plugged in or after extended power outage
 - Wait 24 hours for temperature in both compartments to reach selected temperatures

Ice dispenser opens after closing freezer drawer *

- Normal
 - The ice dispenser door may open after closing freezer door to allow access

Warning

This content is compiled from multiple sources and is provided for reference purposes only. It may not be complete or fully applicable to all situations. If you are unable to resolve your issue, please contact the product manufacturer or an authorized service provider for official support.

Document generated by [ManualsFile](#)

