

## Getting Started

### Features (All Refrigerator - 30" and 36" W. Models)

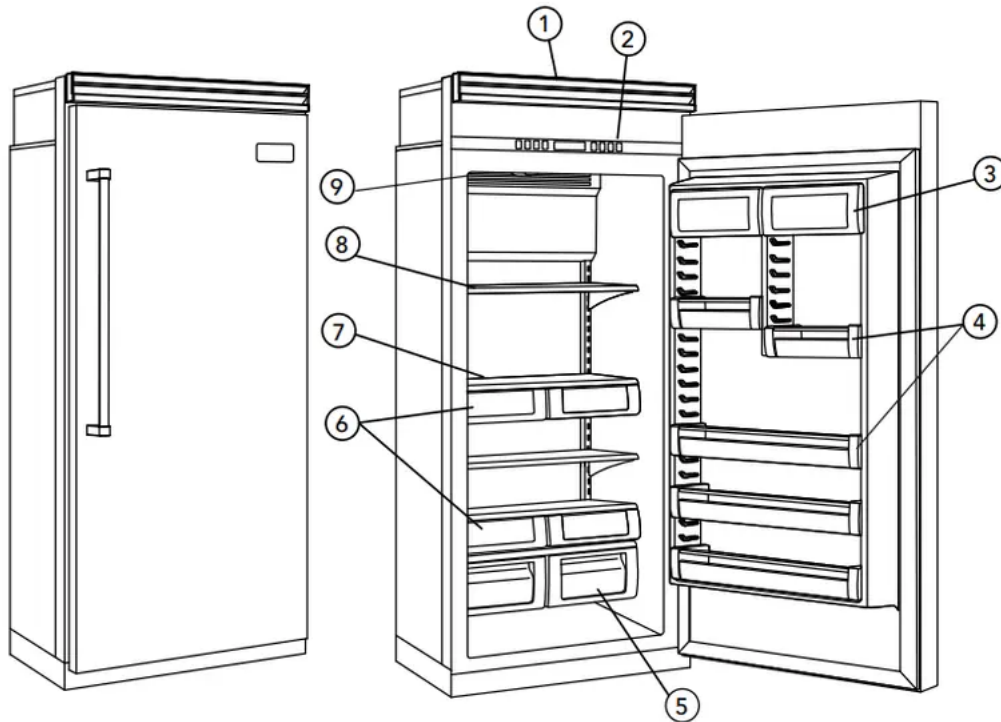

1. Variable Speed DC Overdrive™ Compressor and Super Clog-Resistant™ Condenser
2. Electronic Controls with digital temperature readouts
3. Dairy Compartments (2)
4. Adjustable Door Bins (Patented)  
30" W. Models—  
Full-Width (4)  
36" W. Models—  
Half-Width (2)  
Full-Width (3)
5. Adjustable Humidity Zone™ Drawers (2)
6. Deli Compartment Drawers (4)
7. Spillproof Shelves  
Full-Width (2)
8. Spillproof Shelves Plus Shelf w/Nano Technology  
Full-Width (2)

## 9. LED Lights

### Features (All Freezer - 30" and 36" W. Models)

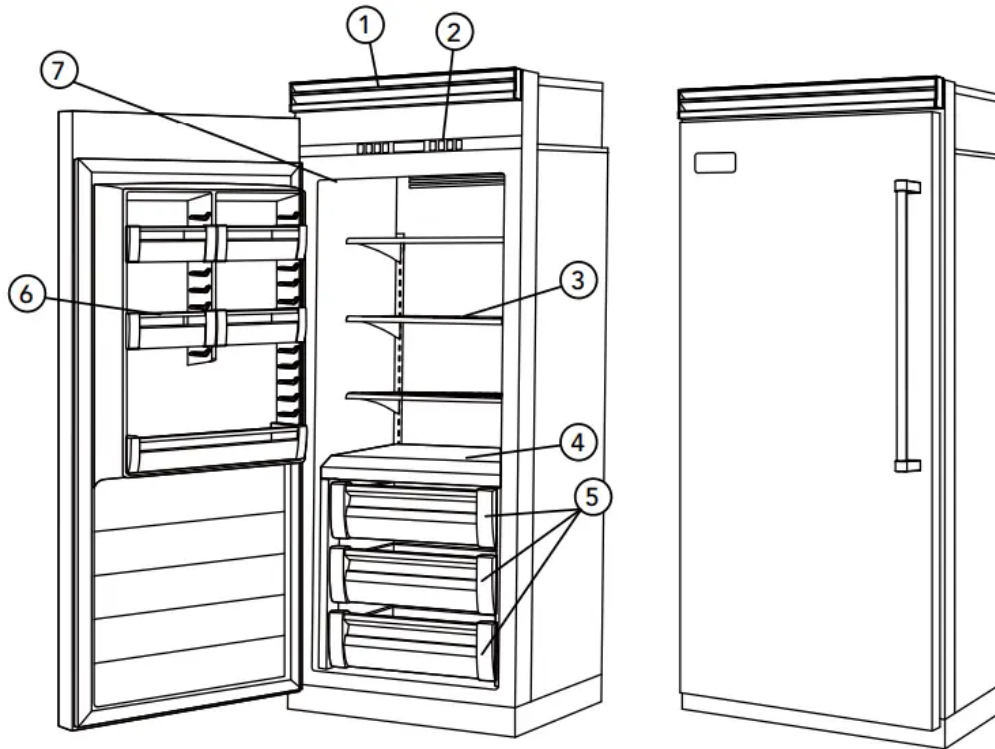

1. Variable Speed DC Overdrive™ Compressor and Super Clog-Resistant™ Condenser
2. Electronic Controls with digital temperature readouts
3. Wire Shelves (3)
4. Non-Adjusting Freezer Shelf (1)
5. Patented Modular Storage System
  - Gliding Ice Drawers (2) with ice Bins
  - Gliding Freezer Baskets (2)
6. Adjustable Door Bins (Patented)
  - 30" W. Models–
    - Full-Width (3)
  - 36" W. Models–
    - Half-Width (4)
    - Full-Width (1)
7. LED Lights

# Product Controls

## Settings and Functions

In order for your new refrigerator to work properly, it is important that you understand its various features, controls, and how to use them.

### Power On/Off Switch (Power Interruption Switch)

The power on/off switch is located behind your refrigerator's top grille. It is used to turn the power off when cleaning the refrigerator. Your refrigerator arrives from the factory with the power interruption switch on.

To turn power off, remove the center grille blade. Press the power on/off switch to the off position.

To turn power on, press power on/off switch to the on position. Replace the center grille blade.

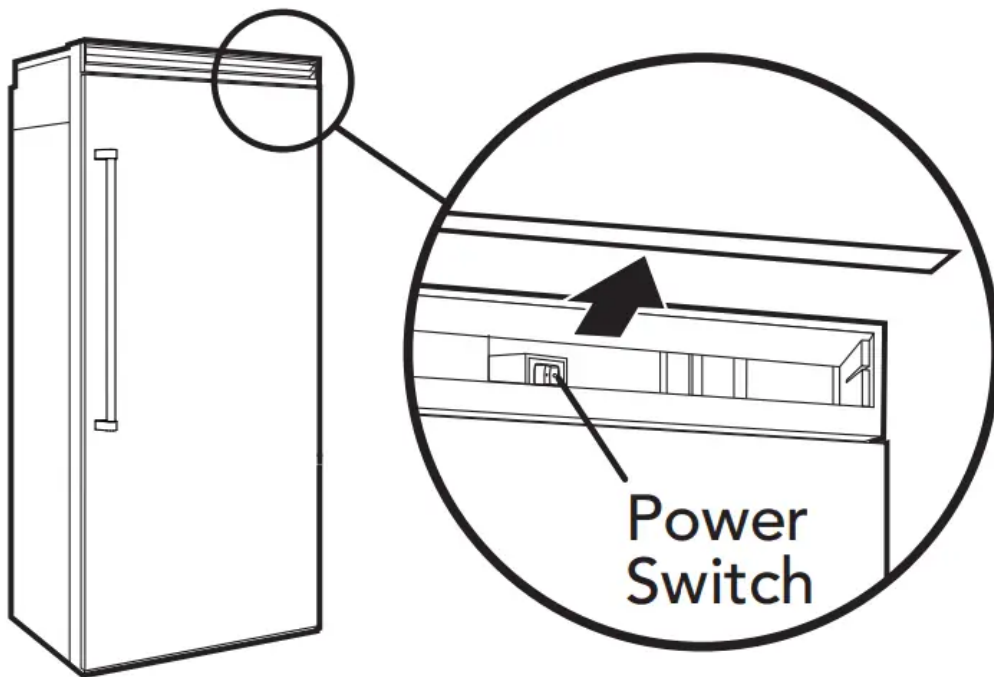

**IMPORTANT:** Be sure the power on/off switch is in the on position after cleaning or changing light bulbs.

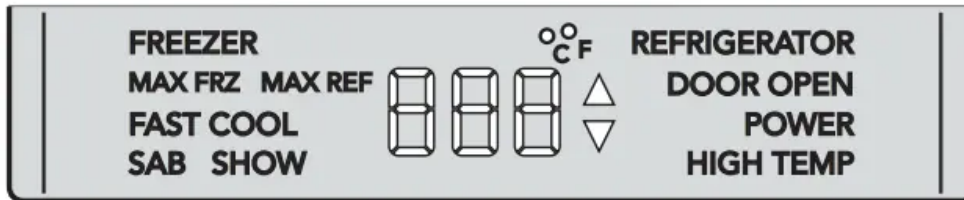

### Showroom Mode Initiation

Showroom mode allows electronic controls and interior lights to function independently of refrigerator system.

To enter the showroom mode: Press and hold "ACTIVATE CONTROLS" pad; while holding, press and hold the "HIGHER" and "ALARM OFF" pads together for 3 seconds. Three beeps will sound and SHOW will be lit. Showroom mode is entered.

To exit the showroom mode: press and hold "ACTIVATE CONTROLS" pad; while holding, press and hold the "HIGHER" and "ALARM OFF" pads together. Three beeps will sound and control will revert to normal operation and display.



### Electronic Temperature Settings

Your refrigerator's electronic controls are located behind the door above the cabinet interior. To activate the electronic control panel, press "ACTIVATE CONTROLS" pad. All other pads, except the "ALARM OFF" pad, will remain inactive until the "ACTIVATE CONTROLS" pad is pressed. Once activated, pad remains programmable for at least ten minutes.

When you first plug your new refrigerator in, you will find that the refrigerator is factory set at 38° F in the refrigerator and 0° F in the freezer. Wait 24 hours after plug-in for the cabinets to reach this setting. After 24 hours, you may adjust controls as desired. To change from °F to °C, press and hold "ACTIVATE CONTROLS" then press and hold "ALARM OFF" for 3 seconds. To change back, follow the same steps. To adjust the refrigerator or freezer temperature, simply press the "ACTIVATE CONTROLS" pad, then "Ref Temp" pad or "Frz Temp" pad. Press the "HIGHER" or "LOWER" pad to adjust temperature setting one degree at a time.



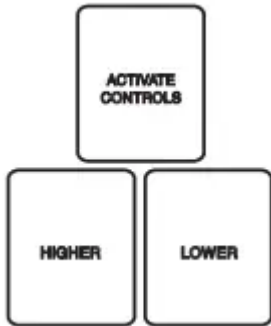

**Note:** Allow 24 hours for temperature to reach desired setting after any change in set temperature.



### Entry Tone

The entry tone is the “beep” you will hear when you press the control pad. You can deactivate the entry tone by pressing and holding the “ACTIVATE CONTROLS” pad for three to five seconds. You will hear three short beeps to let you know that the entry tone feature has been deactivated.

To activate the entry tone, simply press and hold the “ACTIVATE CONTROLS” pad for three to five seconds.

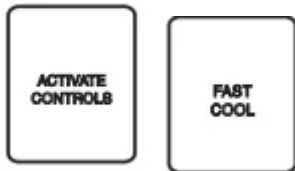

### Fast Cool

Fast Cool runs the compressor at high speed for 2 hours to cool the refrigerator as quickly as possible. After 2 hours, the refrigerator will return to the previous setting.

To activate fast cool, press “ACTIVATE CONTROLS” followed by the “FAST COOL” pad. The fast cool light will be lit.



### Max Refrigerator Mode

Max refrigerator mode adjusts the refrigerator temperature to the coldest setting for four hours, at the end of which the refrigerator's temperature automatically returns to its previous setting.



To activate the max refrigerator mode, simply press the "ACTIVATE CONTROLS" pad, followed by the "MAX REF" pad.

The "MAX REF" light will glow to let you know you've turned on the max refrigerator mode.

To deactivate the max refrigerator mode before the end of the four hour cycle, press the "ACTIVATE CONTROLS" pad, followed by the "MAX REF" pad.

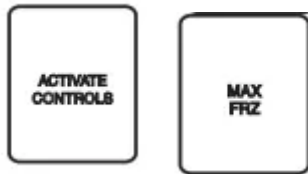

### Max Freezer Mode

Max freezer mode adjusts the freezer temperature to the coldest setting for 6 hours, at the end of which, the freezer temperature automatically returns to its previous setting.

To activate the max freezer mode, press the "ACTIVATE CONTROLS" pad, followed by the "MAX FRZ" pad. The "MAX FRZ" light will glow to let you know you have turned on the max freezer mode.

To deactivate the max freezer mode before the end of the 6 hours cycle, simply press the "ACTIVATE CONTROLS" pad, followed by the "MAX FRZ" pad.



### Door Open Alarm

Door open alarm sounds and the "DOOR OPEN" light blinks if either door is left open for more than three minutes.

To deactivate the door open alarm, press the "ALARM OFF" pad or close the door that is open.



### High Temperature Alarm





To deactivate temperature display, press the "ACTIVATE CONTROLS" pad, followed by the "DISPLAY OFF" pad.



### **Sabbath Mode**

Sabbath mode is used to disable interior lights and alarms for observance of the Sabbath.

Before the Sabbath mode is engaged, the bale arm of the ice maker needs to be raised until it clicks into the detent. This turns off the power to the ice maker.

To enter Sabbath mode, press the "ACTIVATE CONTROLS" pad to activate the control panel. Then, press and hold "Activate Controls" and "Display Off" pads simultaneously for three seconds. It will beep three times and light the SAB indicator so you will know that you have activated Sabbath mode.

When your refrigerator is in Sabbath mode, interior lights, display (excluding SAB indicator, temperature, and compartment indicator), and alarms are disabled.

If your refrigerator loses power while in Sabbath mode, it will return to the Sabbath mode when power is reestablished.

To exit the Sabbath mode, press the "ACTIVATE CONTROLS" pad. Then, press and hold "ACTIVATE CONTROLS" and "DISPLAY OFF" pads simultaneously for three seconds. You will then hear three beeps letting you know that you have turned the Sabbath mode off.

Once your refrigerator has left the Sabbath mode, the bale arm of the ice maker needs to be pushed downward until it is no longer in the detent. This will restore power to the ice maker.

## **Operation**

### **Refrigerator**

#### **Spillproof Plus Shelves with Nano Technology**

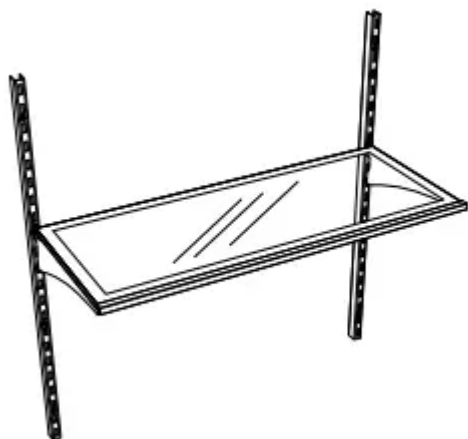

These spillproof shelves contain liquids with no raised edges in order to provide extra shelf capacity.

### **Standard Spillproof Shelves**

Standard spillproof shelves are constructed of polypropylene molded around the glass and metal rail. This design means that the shelves are completely enclosed and liquids can't seep under the glass. This localizes spills and makes clean-up easier.

**Note:** Foods and beverages placed on the uppermost shelf under the air vent may freeze.

### **Shelf Adjustment**

You can adjust the shelves to match the way you use your refrigerator. To remove the shelves, push up on the shelf, tilt upward at the front releasing the hooks from the shelf support, then pull the shelf straight out.

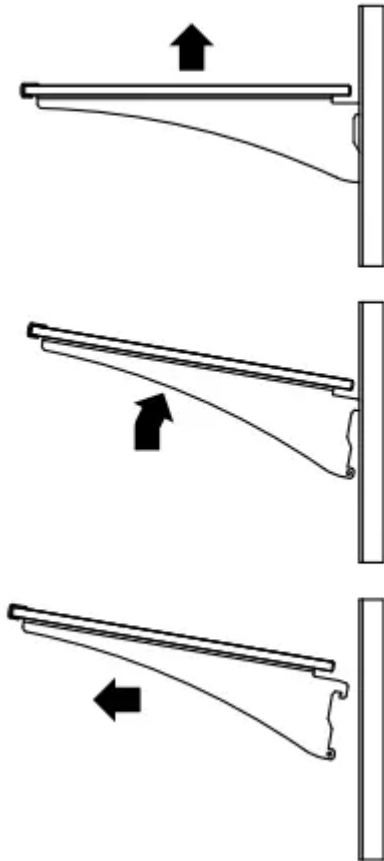

To replace shelves, guide the rear hooks of the shelf into the slots in the shelf supports. Then, tilt the shelf up at the front until the hooks drop into the slots, and lower the front of shelf to level position

### Door Bin Adjustment

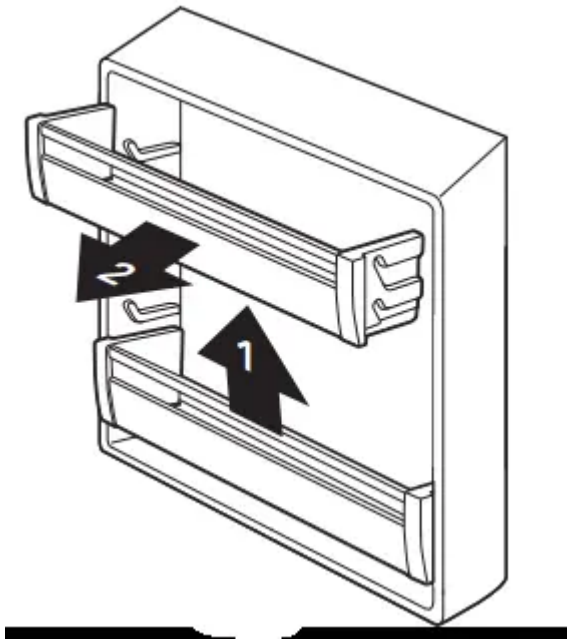

Your refrigerator's door bins hold two-liter bottles and can be placed in any position on the refrigerator door. To remove a bin, simply grasp it, lift the bin up, and pull it out.

To replace the bin, place it over the glides in the refrigerator door, and push the door bin down to lock it into place.

### Dairy Compartments

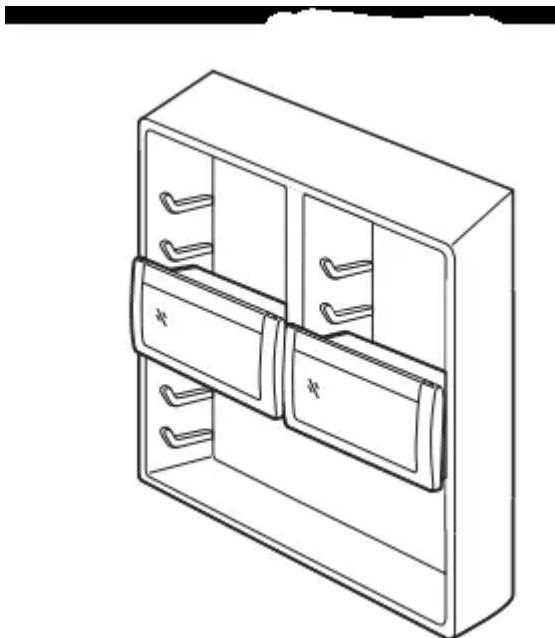

Your refrigerator's dairy compartment doors are surrounded by gaskets for a tighter seal. This allows items to stay fresh much longer. The dairy compartments can be adjusted to meet your unique storage needs.

To remove the dairy compartments, simply grasp, lift up and pull out. To replace, position the dairy compartment over the glides in the refrigerator door, and push the compartment down to lock it into place.

### Deli Drawers

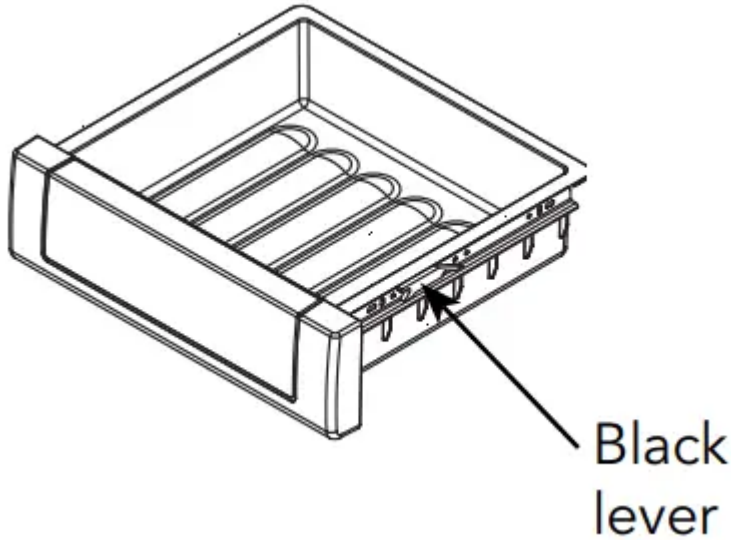

To remove drawer, roll the drawer out to the stop. Then, on each side of the drawer, locate the black lever on the glides and lift up until the drawer disengages from the glides. Pull the drawer out the rest of the way. To replace the drawer, extend the glides out to the stop. Next, place the drawer onto the glides and push it back until the drawer engages the hook. Lower the front part of the drawer, grasp the glides/drawer and lightly squeeze until the drawer snaps onto the glides. Then slide the drawer back until it stops.

### Adjustable Humidity Zone™ Drawer(s)

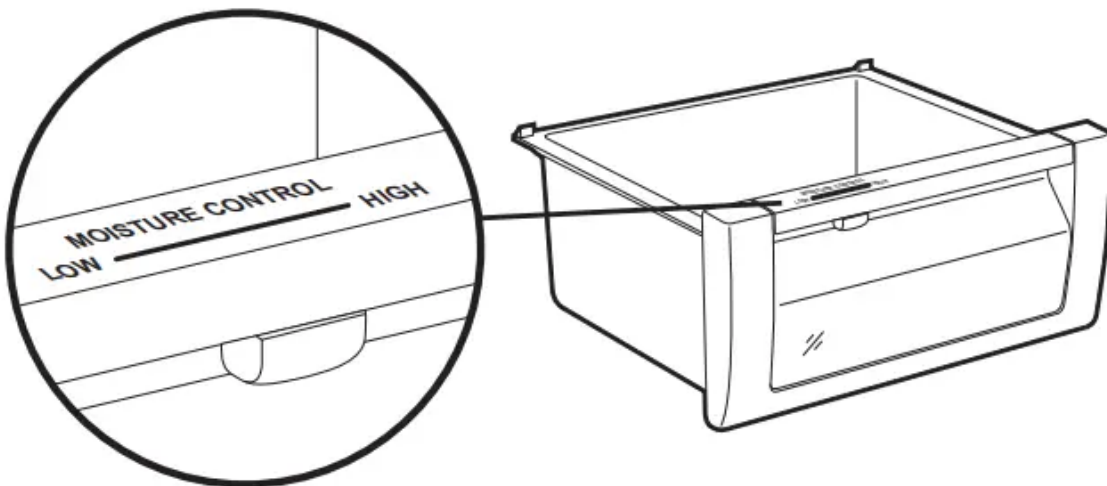

The moisture control on your refrigerator produce drawer(s) gives you the ability to change the amount of moisture or humidity in a drawer, and the clear top section allows you to see into a drawer without opening it. The moisture control is located underneath the front trim. Slide the

control to a higher setting for storing deli items or produce with leaves, such as lettuce, spinach, or cabbage. Slide the control to a lower setting for storing fruits and vegetables with skins, such as apples, corn, or tomatoes. See “Food Storage Guide” (pg. 13) for more information on storing foods properly. To remove drawer, roll the drawer out to the stop. Then, on each side of the drawer, locate the black leveler on the glides and lift up until the drawer disengages from the glides. Pull the drawer out the rest of the way. To replace the drawer, extend the glides out to the stop. Next, place the drawer onto the glides and push it back until the drawer engages the hook. Lower the front part of the drawer, grasp the glides/drawer and lightly squeeze until the drawer snaps onto the glides. Then slide the drawer back until it stops.

## Freezer

### Wire Shelf Adjustment

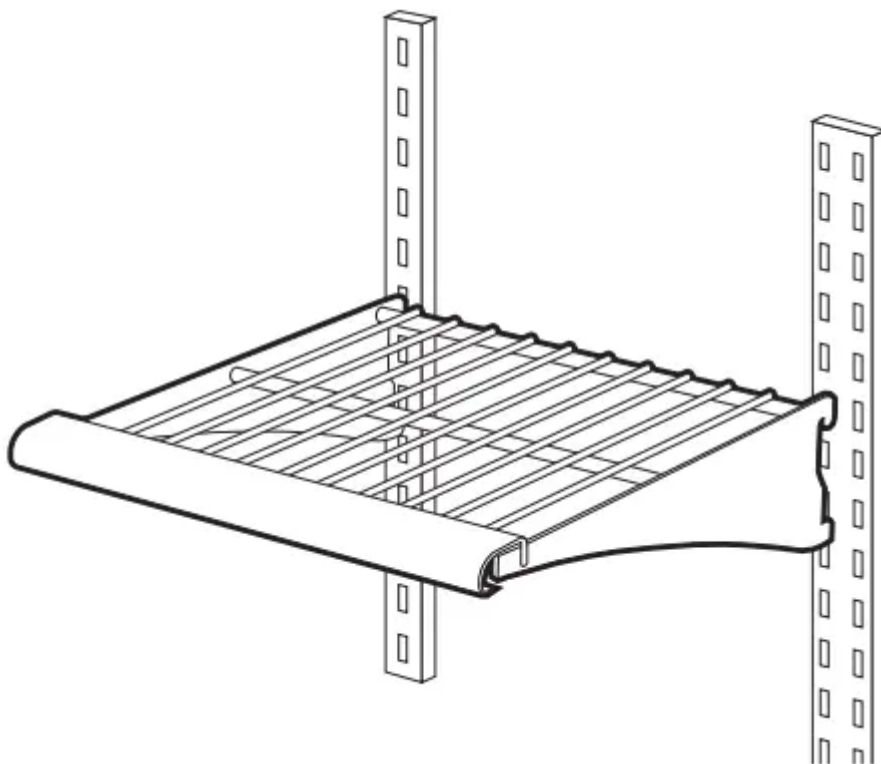

You can easily adjust your freezer’s shelves. To remove a shelf, simply tilt it up at the front, releasing the hooks from the shelf support. Then, pull the shelf straight out. To replace, guide the rear hooks of the shelf into the slots in the shelf supports. Then, tilt the shelf up at the front until the hooks drop into the slots. Next, lower the front of the shelf to a level position.

### Wire Basket Adjustment

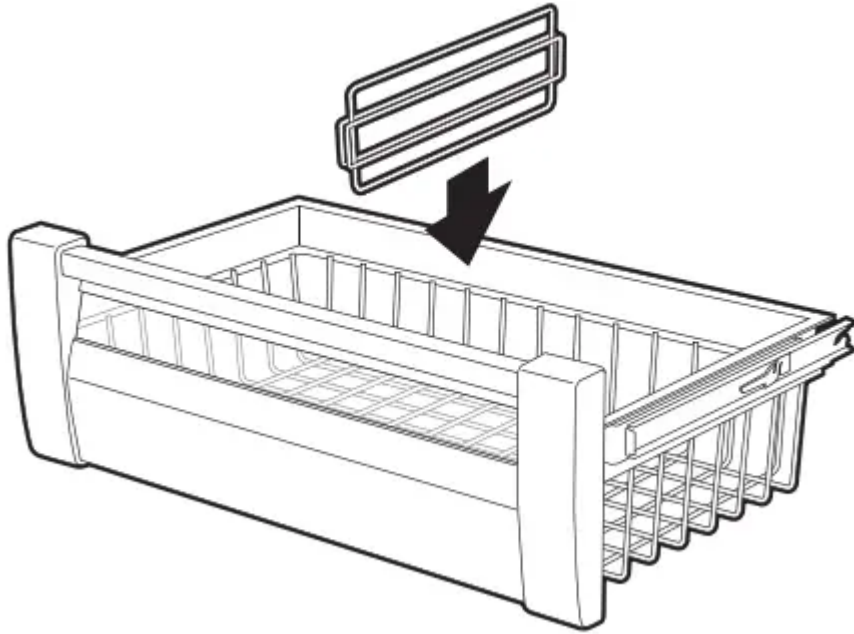

You can easily adjust your freezer's wire baskets by moving the dividers. To remove a divider, simply grasp it in the center, and pull the divider straight up. To replace, guide the divider around the basket wires in the desired location, then push the divider down until it stops.

#### **Automatic Ice Maker**

The ice maker and slide-out ice drawer on your refrigerator are not adjustable, but the ice drawer slides forward for easy access to ice.

After the refrigerator reaches normal temperature, the ice maker fills with water and begins operating. Under normal conditions, the ice maker will produce seven to nine batches of ice per 24 hour period.

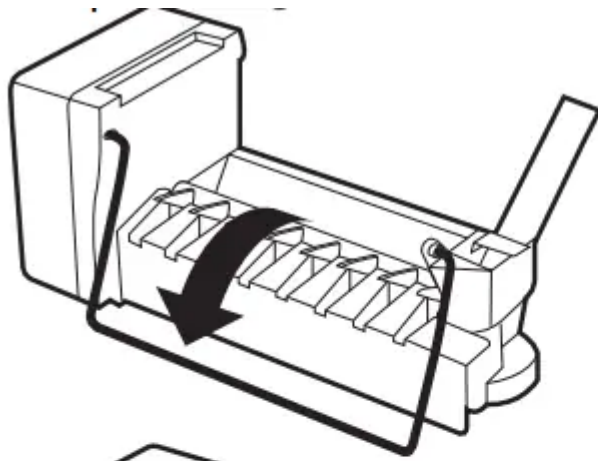

**On  
Position**

**Ice  
Maker  
Arm**

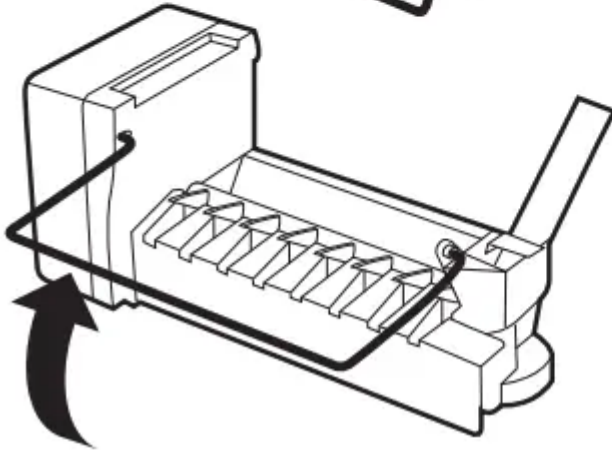

**Off  
Position**

**Note:** Allow 24 to 48 hours after installation before looking for ice in your ice drawer.

You should discard the first three full drawers of ice produced by your refrigerator, and should also throw out the first drawer full of ice your refrigerator produces after extended periods of non-use.

During ice production, the ice maker arm raises and lowers. When the ice bin is full, the ice maker arm automatically turns the ice maker off. To manually stop ice production, raise the ice maker arm. You will hear a definite click when you have the arm in the right position. The ice maker won't produce any more ice until you lower the ice maker arm.

### **Ice Bin Adjustment**

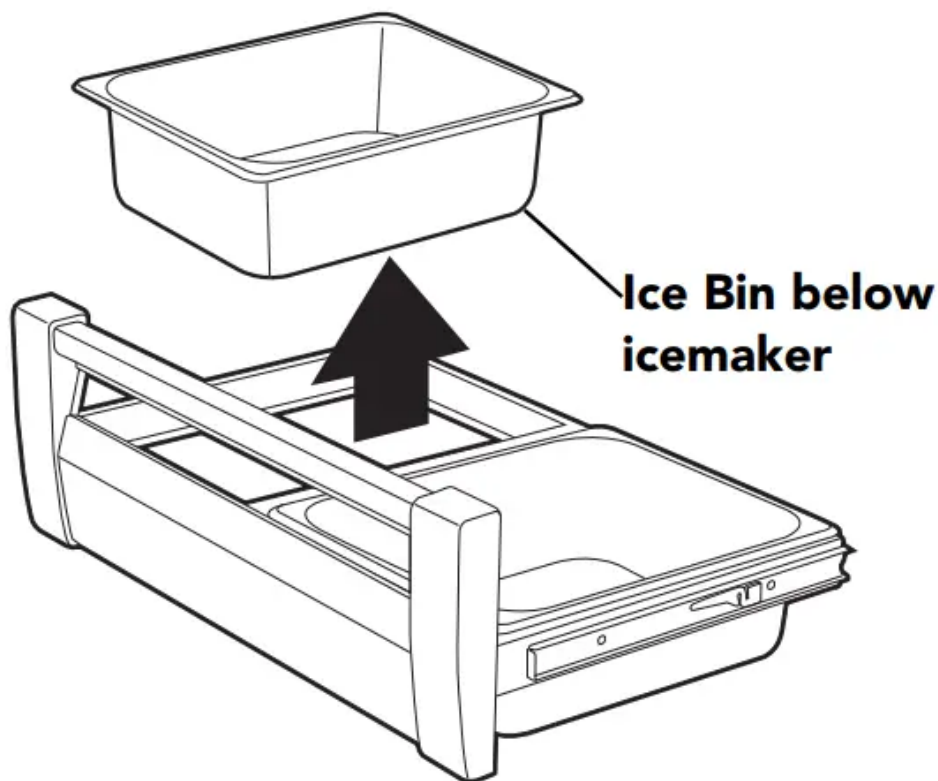

Ice bins can be adjusted to match the way you use your freezer. The ice bin on the left-hand side is used for collecting ice from the ice maker. Once the lefthand ice bin is full, the bins can be reversed so additional ice is made. If the ice maker is not operating, the ice bin can be used for cold storage.

## **Food Storage Guide**

### **Storing Fresh Food**

Wrap or store food in the refrigerator in airtight and moisture-proof material. This prevents food odor and taste transfer. For dated products, check use-by date to ensure freshness.

To store leafy vegetables, remove store wrapping. Then tear off bruised and discolored areas. Wash the vegetables in cold water and drain, and then place them in a plastic bag or plastic container and store in your produce drawer.

For vegetables with skins, such as carrots and peppers, store in plastic bags or containers.

When refrigerating or freezing fruit, wash the fruit and then let it dry. Store the fruit in plastic bags. Don't wash or hull berries until they are ready to use. Instead, sort and keep berries in their original container in the produce drawer, or store in a loosely closed paper bag on the refrigerator shelf.

Store eggs without washing them. Keep eggs in their original carton or in your refrigerator's egg bin.

Wipe milk cartons. For best storage, place milk on an interior shelf.

Keep opened butter in covered dish or closed compartment. When storing butter in the freezer, wrap it in freezer packaging.

When you have leftovers, cover them with plastic wrap, aluminum foil, or store the leftovers in plastic containers with tight lids.

Store meat in its original wrapping, as long as it's airtight and moisture-proof. Rewrap meat if necessary.

**Note:** When storing meat longer than the recommended times, freeze the meat.

**Recommended storage times:**

- Chicken 1-2 days Bacon 5-7 days
- Ground Beef 1-2 days Cold Cuts 3-5 days
- Steaks/Roasts 3-5 days Variety Meats 1-2 days
- Cured Meats 7-10 days

**Note:** Use fresh fish and shellfish the same day as purchased.

**Packaging Food for Freezing**

The secret of successful freezing is in the packaging; the way you close and seal a package of food must not allow air or moisture in or out, or the quality of the food will deteriorate while frozen.

**Packaging you should not use for freezing includes:**

- Bread wrappers
- Non-polyethylene plastic containers
- Containers without lids
- Wax paper or wax-coated freezer wrap
- Thin, semi-permeable wrap

**Recommended packaging:**

- Rigid plastic containers with tight-fitting lids
- Straight-sided canning/freezing jars
- Heavy-duty aluminum foil
- Plastic-coated paper
- Non-permeable plastic wraps (made from saran film)
- Zip-top freezer bags

**Follow package or container instructions for proper freezing methods.**



## Freezing Foods

**DO NOT** expect your freezer to quick-freeze large quantities of food; **DO NOT** load more than two to three pounds of unfrozen food per cubic foot within 24 hours. Leave enough space for air to circulate around packages, and be careful to leave enough room at the front so the freezer door can close tightly.

A full freezer stays cold longer than a partially filled one, and a freezer full of meat stays cold longer than a freezer full of baked goods. If food contains ice crystals, it may be safely refrozen, although the quality and flavor may be affected. If the condition of the food is poor, or if you feel it is unsafe, dispose of it.

Storage times will vary according to the quality of food, the type of packaging or wrap used (airtight and moisture-proof), and the storage temperature, which should be 0° to 2°F (-18° to -17° C).

## Product Care

### Cleaning & Maintenance

Your refrigerator is built to give you many years of dependable service. However, there are a few things you can do to help extend its life. This section tells you how to clean your refrigerator and what to do when going on vacation, moving, or during a power outage.

#### Interior Surfaces

Wash the interior surfaces of your refrigerator with four tablespoons of baking soda dissolved in one quart of warm water. Use a soft, clean cloth. Rinse these surfaces with warm water, and dry with a soft clean cloth.

**DO NOT use the following to clean interior surfaces:**

- Abrasive or harsh cleaners, such as ammonia or chlorine bleach
- Concentrated detergents or solvents
- Metal scouring pads

These products can scratch, crack and discolor your refrigerator's surfaces. Also, NEVER wash the ice bucket or shelves in the dishwasher. They must be cleaned by hand.

#### Glass Shelves

To clean your refrigerator's glass shelves, lift the shelf out by lifting the front and releasing the hooks from the metal track.

Then pull the shelf out. Be sure to allow the glass shelves to adjust to room temperature before cleaning.

To clean crevices, dilute mild detergent with water. Brush this solution into crevices using a plastic bristle brush. Let set for five minutes. Spray warm water into crevices using faucet spray

attachment. Dry glass shelf thoroughly and replace shelf by inserting hooks into metal track and lowering front.

### **Door Gaskets**

Clean the door gaskets every three months using the same procedures used for interior surfaces. You should apply a light film of petroleum jelly to keep gaskets pliable.

### **Defrost Pan**

To prevent condensation from overflowing, check defrost pan periodically.

To check defrost pan, remove two screws securing kickplate to unit. Pull defrost pan forward until it stops. Remove any excess water from pan. Wipe and clean defrost pan with a sponge. Return defrost pan to original position. Return kickplate to unit by securing with two screws.

## Cleaning Chart

Part	What to Use	How to Clean
<b>Removable parts</b> (shelves, drawers)	Sponge or cloth with mild detergent and warm water	Hand wash, rinse, and dry thoroughly.
<b>Front door panels</b> <ul style="list-style-type: none"> <li>• stainless steel</li> <li>• painted</li> </ul>	Stainless steel cleaner  Sponge or cloth with mild detergent and warm water.  DO NOT use cleaners containing chlorine bleach.	Wipe with soft cloth. Hand wash, rinse, and dry thoroughly
<b>Interior walls</b> ( allow freezer to warm up so cloth will not stick)	Sponge, soft cloth or paper towel with baking soda or mild detergent and warm water	Hand wash, rinse, and dry thoroughly.
<b>Door liners and gaskets</b>	Sponge, soft cloth or paper towel with mild detergent and warm water.  DO NOT use cleaning waxes, concentrated detergents, or cleaners containing chlorine bleach.	Wash, wipe, and dry thoroughly.
<b>Plastic parts</b> (covers, panels)	Soft, clean sponge or soft clean cloth with mild detergent and warm water. DO NOT use paper towels, window sprays, or scouring pads. These can scratch and damage the finish.	Wash, wipe, and dry thoroughly.
<b>Super Clog-Resistant™ Condenser*</b>	Vacuum cleaner with extended narrow attachment	Vacuum coils when dusty or dirty

\* Under normal conditions, condenser is maintenance-free.

## Door Stop Adjustment



Your refrigerator is factory set at the 110° door stop position. To change to either the 90° or 120° position, remove the door stop pin using a 3/16" (0.5 cm) allen wrench.

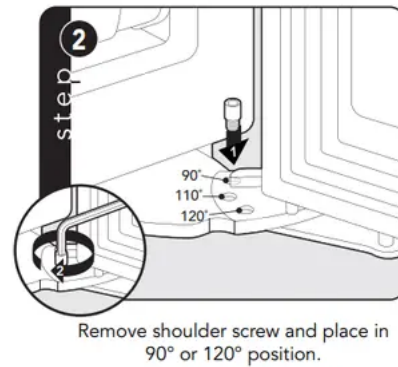
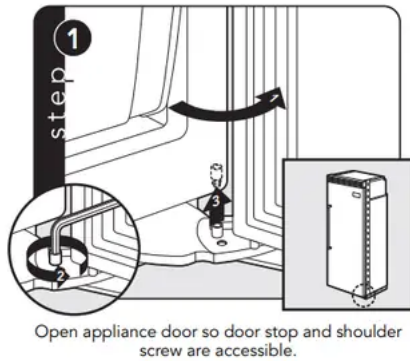

### Saving Energy

You can help your appliance use less electricity with these simple tips:

- Open the door as few times as possible. Think about what you need before you open the door. Get everything out at one time. Keep food organized so you will not have to search for what you want. Close door as soon as food is removed.
- DO NOT overcrowd the unit so air movement is blocked.
- DO NOT set the unit to temperature colder than necessary.

### Vacation Tip

When you will be gone from home a short time (less than four weeks), there is no need to shut off your refrigerator. However, be sure to:

- Use any perishables.
- Freeze other items.
- Raise the signal arm in the automatic ice maker to the off (up) position and shut off water supply to the ice maker.

If you will be away from home for a month or more, follow these guidelines:

- Remove all food and ice.
- Turn the power disconnect switch to the off position.
- Clean the unit and door gaskets according to the "Cleaning and Maintenance" chart on page 15.
- Prop doors open with rubber or wood blocks so air can circulate inside. This will keep odor and mold from building up.
- Raise the signal arm in the automatic ice maker to the off (up) position and shut off water supply to the ice maker.

### Power Interruptions

If electric service to your freezer will be interrupted for 24 hours or less, keep the doors to the freezer closed. This helps food stay frozen.

If service will be interrupted longer than 24 hours, remove all frozen food and store it in a frozen food locker, or place two pounds of dry ice inside the freezer for every cubic foot of interior volume. This will keep food frozen for two to four days. Be sure to wear gloves to protect your hands from dry ice burns. If neither a food locker or dry ice is available, you should use or can your perishable food at once.

## Troubleshooting

### Understanding Sounds You May Hear

Your new refrigerator may make different sounds than your old one. Hard surfaces, such as the ceilings, walls, and cabinets around the unit can make these sounds seem louder. However, these sounds are normal and will soon become familiar; they indicate that your refrigerator is working properly.

Here are some of the noises you may hear and what they are:

- Freezer or refrigerator fresh food fan: sounds like air rushing or whirling
- Sealed system (evaporator and heat exchanger) refrigerant flow: sounds like gurgles, pops or boiling water
- Defrost heater: sizzles, hisses or pops
- Condenser fan: air rushes and whirls
- Compressor: has a high pitched hum or pulsating sound
- Ice maker valve hookup: buzzes when ice maker fills with water. This occurs whether or not the unit is connected to water supply. If the unit is not connected to water supply, stop sound by raising ice maker arm to off position.

**Most performance problems you might encounter with your new refrigerator will be minor and you should be able to fix them yourself without tools.**

Listed below are the most common problems consumers run into with their appliances. Please read through this and see if it can solve your problem before calling for service

## Common Problems

<b>Problem</b>	<b>Possible Cause And/Or Remedy</b>
Unit will not operate	Is the power cord plugged into a live circuit with the proper voltage? Has a household fuse blown or circuit breaker tripped? Is the power switch in the on position?
Unit makes unfamiliar sounds	See “Understanding Sounds You May Hear” on page 35 for descriptions of normal sounds and what makes them.
Water in the defrost pan	This is normal in hot, muggy weather. Make sure the pan is level so it does not overflow.
Lights do not work	Has a household fuse blown or circuit breaker tripped? Is a bulb burned out? For models with LED lighting, contact an authorized service agency.
Motor seems to run too long	The motor naturally runs longer on hot days, if the room is too warm, if a large amount of food has been added, or if the doors are opened often.
Temperature display does not match set point	Just plugged in unit, just put in hot food, opened the door for an extended time or frequently. Allow unit to stabilize for 24 hours.
Ice crescents attached at corners	This is normal. They break apart easily. Shake bin occasionally to keep cubes separated
Ice maker will not operate or ice is not made fast enough	<ul style="list-style-type: none"> <li>• On/off lever is in the OFF (up) position. Lower lever to ON (down) position.</li> <li>• Is the water valve turned on? Is water getting to the water valve? Check water line for leaks.</li> <li>• Freezer is not cold enough. Adjust temperature controls and wait 24 hours.</li> </ul>
Off-taste or odor in ice	<ul style="list-style-type: none"> <li>• New plumbing connections can cause discolored or off-flavored ice. Discard the first three harvests of ice.</li> <li>• Cubes are stored too long. Throw them away and make a new supply.</li> <li>• Food is not wrapped properly</li> <li>• Freezer and ice bin need to be cleaned</li> </ul>



- Water may contain minerals. A filter may be needed to remove them.

**Warning**

This content is compiled from multiple sources and is provided for reference purposes only. It may not be complete or fully applicable to all situations. If you are unable to resolve your issue, please contact the product manufacturer or an authorized service provider for official support.