

# USING THE REFRIGERATOR

## Features

### 1. Space-saving icemaker

Icemaker and bin are located on the door creating more usable storage space.

### 2. Showcase LED lighting

LED lighting is positioned throughout the interior to spotlight areas in the refrigerator. LEDs are located under the fresh food door to light the freezer when opened.

### 3. Drop-down tray\*

Allows for extra door storage when you need it and tucks away when you don't.

### 4. Full-width temperature controlled drawer

Adjustable temperature control bin that can accommodate larger items.

### 5. Dairy bin

Separate compartment for your items.

### 6. Dual ice maker/Ice bin (on some models)

An ice maker in both compartments gives you more ice whenever you need it

### 7. QuickSpace™ shelf\*

Functions as a normal full-sized shelf when needed and easily slides back to store tall items below.

### 8. Spillproof shelves

Designed to capture your spills for easier clean up.

### 9. Anti-slip Mat

Liner that captures spills, keeps containers from shifting when the door is opened and is easily removable for cleaning.

### 10. Removable door bin

Can be removed for those with a wall limiting the door opening.

### 11. Climate zone bin

Separate bins for produce storage.

### 12. Water filter

Filters water and ice.

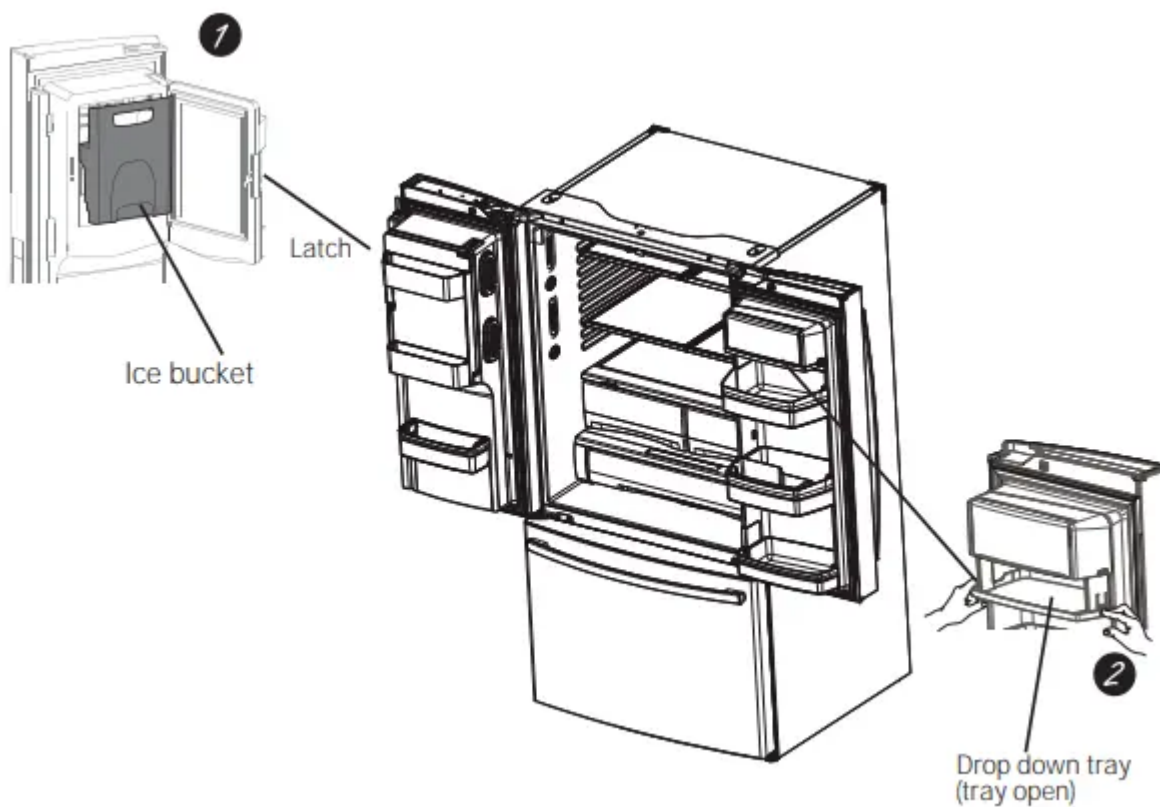

### 1 Door ice bin\*

1. Open left fresh food door.
2. Pull down latch to release bin door.
3. Using handhold lift ice bucket up and out to clear locators in bottom of bin.
4. To replace the ice bucket, set it on the guide brackets and push until the ice bucket seats properly.
5. If bucket can not be replaced, rotate the Ice Bucket Fork 1/4 turn clockwise.

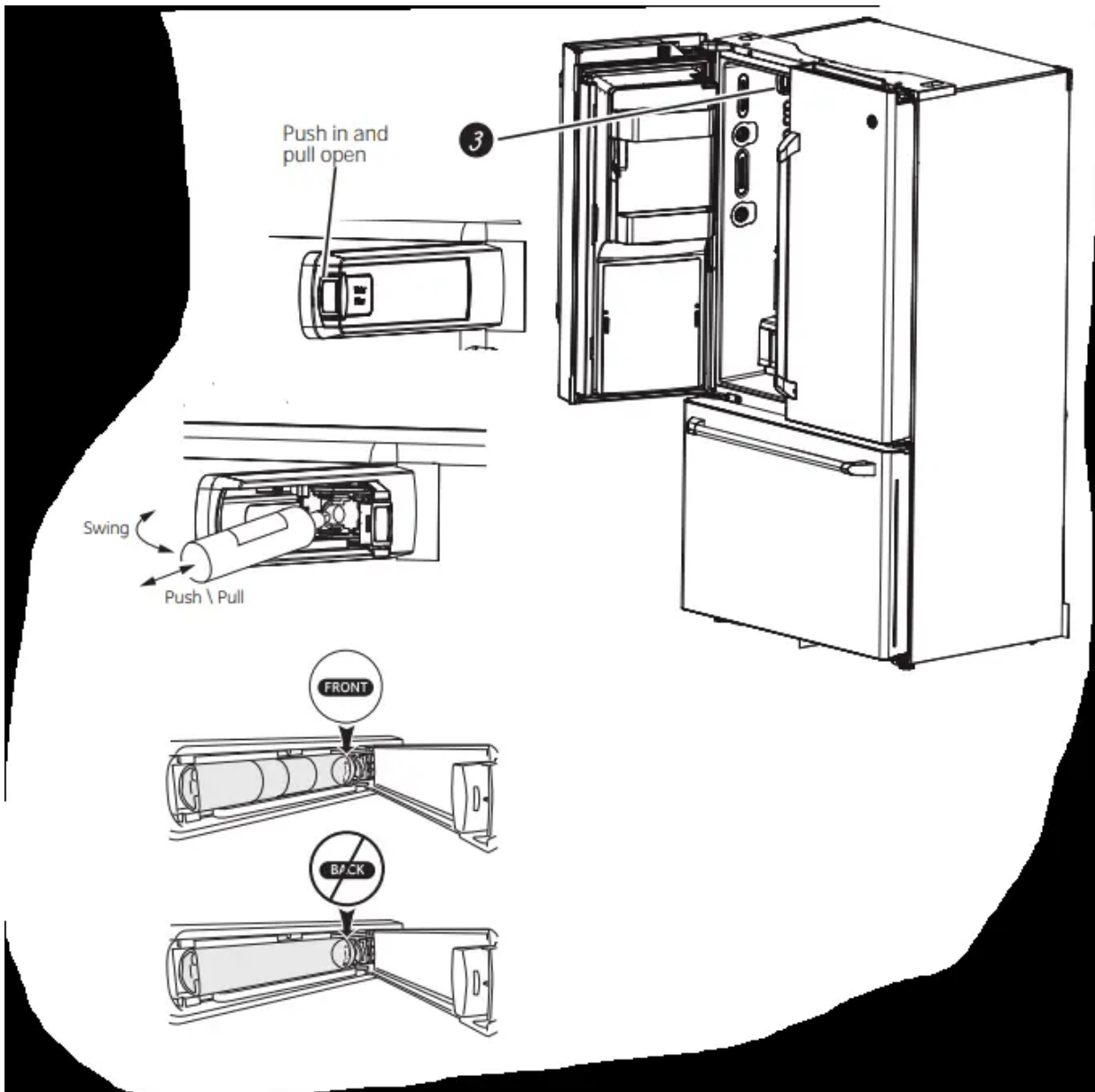

## 2 Drop down dairy bin\*

1. Open right fresh food
2. Depress both buttons on lower sides and bin will drop down.
3. Reverse to instal

## 3. Ice/water filter

Remove filter/bypass plug

Push the indent on the cover and open filter door. Pull out on filter/ bypass plug and pull straight back to remove.

Installing the filter cartridge

Push the indent at the bottom of the cover and open. Lift door and align tabs on filter to filter/holder and push filter into place

## Controls

### GFE28, GFE26, DFE28, GYE22 Control Style B, External Control

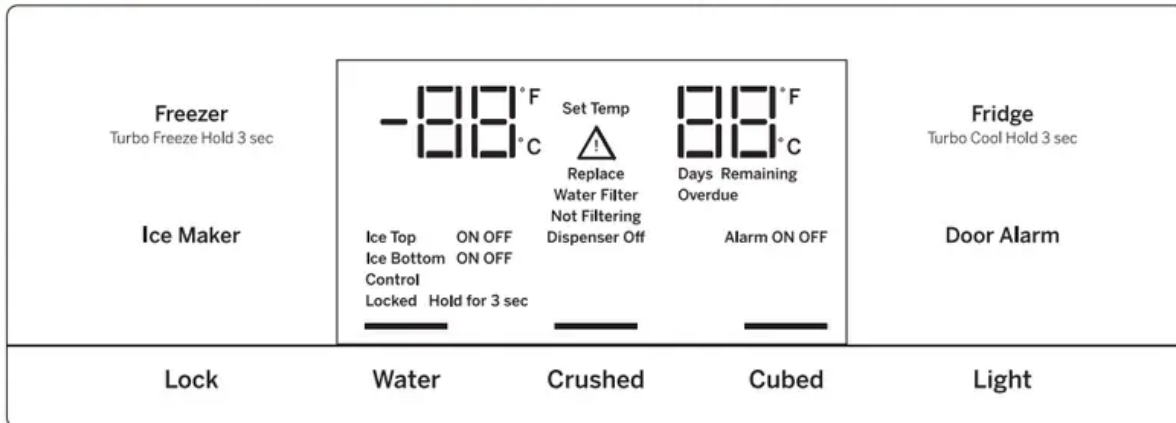

**NOTE:** The refrigerator is shipped with protective film covering the temperature controls. If this film was not removed during installation, remove it now.

The temperature controls are preset in the factory at 37°F for the refrigerator compartment and 0°F for the freezer compartment. Allow 24 hours for the temperature to stabilize to the preset recommended settings.

The temperature controls can display both the SET temperature as well as the actual temperature in the refrigerator and freezer. The actual temperature may vary slightly from the SET temperature based on usage and operating environment.

### Changing the Temperature for Control Styles B

To change the temperature, press and release the Freezer or Fridge pad. The display will show the set temperature. To change the temperature, press either the Freezer or Fridge pad until the desired temperature is displayed. To turn OFF cooling system, press and hold Fridge and Ice Maker simultaneously for 3 seconds. When the cooling system is OFF the display should read OFF.

**NOTE:** For optimal temperature performance, we recommend to avoid placing food items directly at the air flow vents of the fresh food air tower and thus blocking the air flow.

## Control Style B, External Controls

GFE28, GFE26,  
DFE28, GYE22

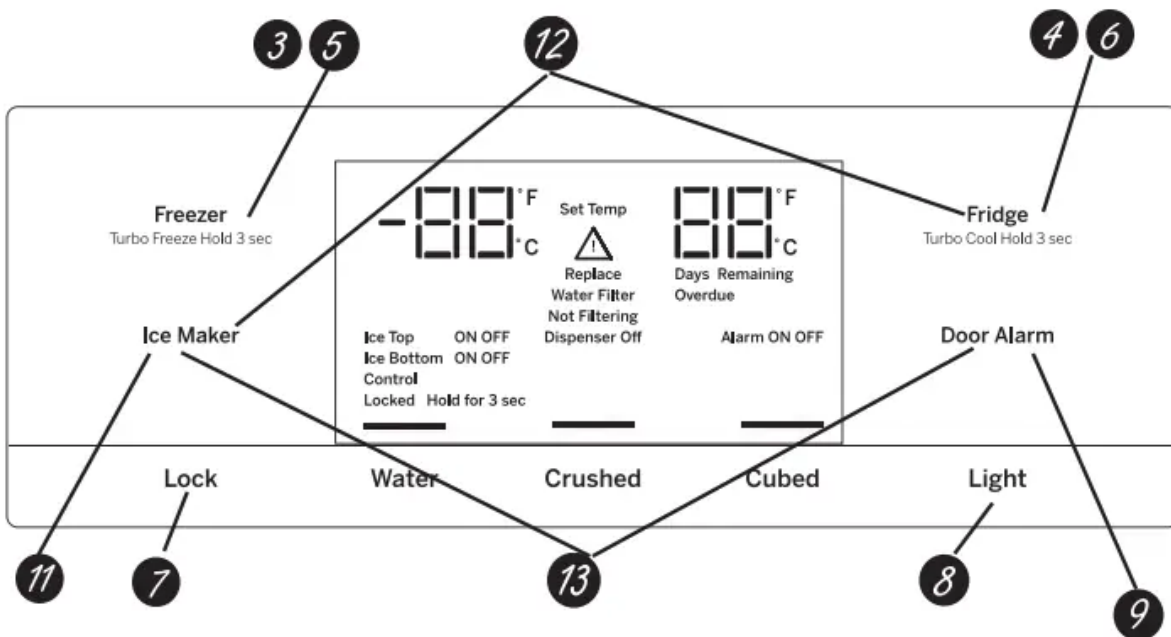

### 1. Hands-free Autofill\*

Hands-free Autofill uses sensors to monitor container height to automatically dispense filtered water without having to activate the paddle.

### 2. PreciseFill setting\*

Precisely dispenses filtered water in accurate measurements in ounces, cups, quarts, or liters using paddle.

### 3. Refrigerator temp control

Adjust freezer compartment temperature.

### 4. Fresh food temp control

Adjust fresh food compartment temperature.

### 5. TurboFreeze™ setting

Activate TurboFreeze to quickly restore freezer temperatures after frequent door openings.

### 6. TurboCool™ setting

Activate TurboCool to quickly restore fresh food temperature after frequent door openings.

### 7. Lock controls

Press and hold 3 seconds to lock out ice and water dispenser and all feature and temperature buttons.

## 8. LED dispenser light

LED lighting that can be turned on/off to light your dispenser.

## 9. Door Alarm

Sounds to alert when the freezer or fresh food doors have been left open. Press and hold Door Alarm pad and it will toggle the sound between low, high and off.

## 10. Photo upload\*

Insert USB memory stick to upload personal photos to the refrigerator LCD screen.

LCD will provide on screen prompts to load and view slideshow.

Make sure the photos are in the root directory in your USB.

## 11. Ice maker setting

Turn your ice makers on/off

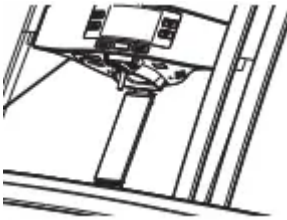

## 12. Cooling system On/Off

Press and hold Fridge & Ice Maker simultaneously for 3 seconds to turn the cooling system on or off.

## 13. Metric/English units

Press and hold Ice Maker & door alarm simultaneously for 3 seconds to switch between Metric & English units.

### Additional settings:

- Photo upload and delete
- Slideshow
- Connected Home ready
- Reset water filter
- Ice maker on/off
- Door alarm
- Sound control
- Cooling system On/Off
- Metric/English units
- Auto fill video tutorial

## Additional Modes

### Sabbath Mode

Press and hold lock & light simultaneously for 3 seconds to enter/exit Sabbath mode. Activate Sabbath Mode to turn off interior lights, temperature control and advanced features. Compressor will run on a timed defrost when in Sabbath mode.

## Dispenser

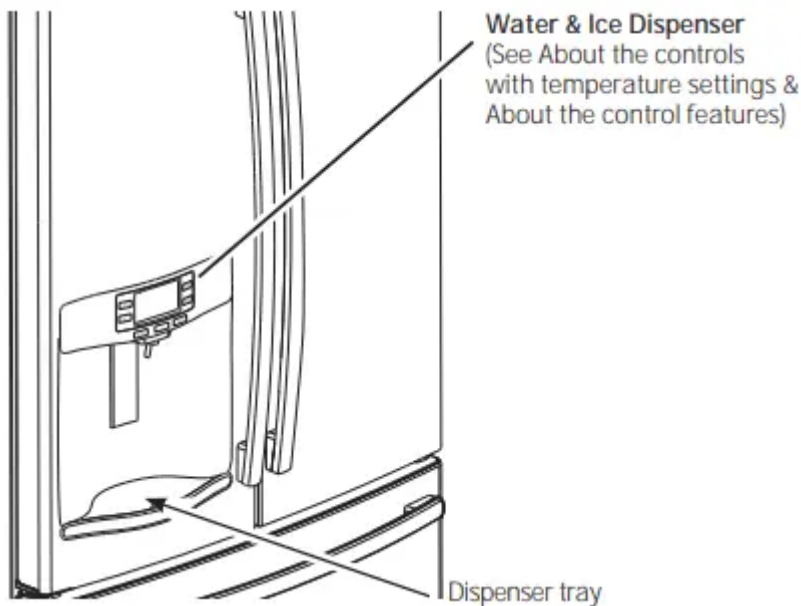

If no water is dispensed when the refrigerator is first installed, there may be air in the water line system. Press the dispenser paddle for at least five minutes to remove trapped air from the water line and to fill the water system. To flush out impurities in the water line, throw away the first six full glasses of water.

### To remove Dispenser Tray (Type B Only)

Pull Dispenser Tray out

### To reinstall Dispenser Tray (Type B Only)

- Center Dispenser Tray and push in until it snaps in place

### Important Facts About Your Dispenser

- Do not add ice from trays or bags to the door ice maker bucket. It may not crush or dispense.
- Avoid overfilling glass with ice and use of narrow glasses. Backed-up ice can jam the chute or cause the door in the chute to freeze shut. If ice is blocking the chute remove the ice bucket, poke it through with a wooden spoon.
- Beverages and foods should not be quick-chilled in the door ice maker bin. Cans, bottles or food packages in the storage drawer may cause the ice maker or auger to jam.

- To keep dispensed ice from missing the glass, put the glass close to, but not touching, the dispenser opening.
- Some crushed ice may be dispensed even though you selected CUBED ICE. This happens occasionally when a few cubes accidentally get directed to the crusher.
- After crushed ice is dispensed, some water may drip from the chute.
- Sometimes a small mound of snow will form on the door in the ice chute. This condition is normal and usually occurs when you have dispensed crushed ice repeatedly. The snow will eventually evaporate.

### **To Use the Internal Water Dispenser\***

The water dispenser is located on the left wall inside the refrigerator compartment.

To dispense water:

1. Hold the glass against the recess.
2. Push the water dispenser button.
3. Hold the glass underneath the dispenser for 2-3 seconds after releasing the dispenser button. Water may continue to dispense after the button is released.

If no water is dispensed when the refrigerator is first installed, there may be air in the water line system. Press the dispenser button for at least 5 minutes to remove trapped air from the water line and to fill the water system. During this process, the dispenser noise may be loud as the air is purged from the water line system. To flush out impurities in the water line, throw away the first 6 glassfuls of water.

NOTE: To avoid water deposits, the dispenser should be cleaned periodically by wiping with a clean cloth or sponge.

### **AUTOFILL\***

#### **To Use HANDS FREE AUTOFILL:**

- Center container on Recess Dispenser Tray as far back as possible without activating paddle and remove hand from container
- Press AUTOFILL

#### **To Stop AUTOFILL**

- Press AUTOFILL to stop.

#### **Important Facts about AUTOFILL**

- For optimum results, use a uniform container between 4-8" (10-20 cm) tall and 2-6" (5-15 cm) wide.
- Container shape, fill level and functionality may vary on containers taller than 8"

- Container volumes may vary, if error message “Not Found” is given, try a different container.
- AUTOFILL will time out.
- Handles, straws, and garnishes on the rim of the container may cause overflowing or variation in fill volumes.
- Splashing may occur depending on the location of the container, water flow rate, container shape, and ice cubes.
- Keep sensors clean with a clean damp cloth, and do not spray liquid or cleaners directly on sensors
- AUTOFILL works best with household water pressure of 60 to 100 psi

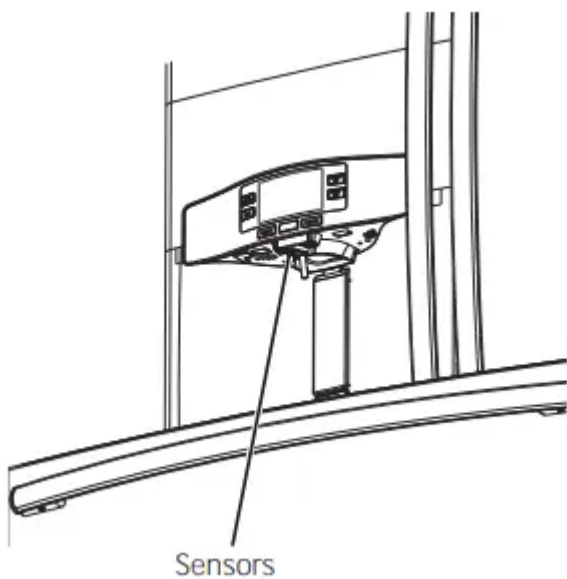

## Water Filter Cartridge - RPWFE

### Water Filter Cartridge

The water filter cartridge is located in the fresh food interior on the left side wall, near the top.

Select models use radio frequency identification (RFID) to detect leaks and monitor filter status.

The RFID technology is certified by the FCC.

### When to replace the filter cartridge

The filter cartridge should be replaced every six months or earlier if 170 gallons of water has been dispensed or the flow of water to the dispenser or icemaker decreases.

**Touch Screen Models:** A filter status message will appear on the screen when the water filter needs to be replaced. The filter status will automatically update when the filter is replaced. **Non-**

**touch Screen Models:** A filter indicator light will illuminate on the screen when the water filter needs to be replaced.

## Removing the filter cartridge

To replace the filter, first remove the old cartridge by opening the filter door and pulling on the bottom of the cartridge to allow it to swing outward. When the cartridge can no longer swing, gently pull to unseat it from the cartridge holder. **DO NOT TWIST CARTRIDGE.** A small amount of water may drip out.

## Installing the Filter Cartridge

1. Align top of filter cartridge with cartridge holder with the word "**FRONT**" facing outward then push the cartridge toward

the rear of the unit until it is fully seated. **DO NOT TWIST THE FILTER CARTRIDGE!**

2. While continuing to ensure cartridge is fully seated in the holder, gently swing the filter inward until it is in position. If filter will not swing easily, check to ensure filter is properly aligned and fully seated within the cartridge holder. Close the filter door.

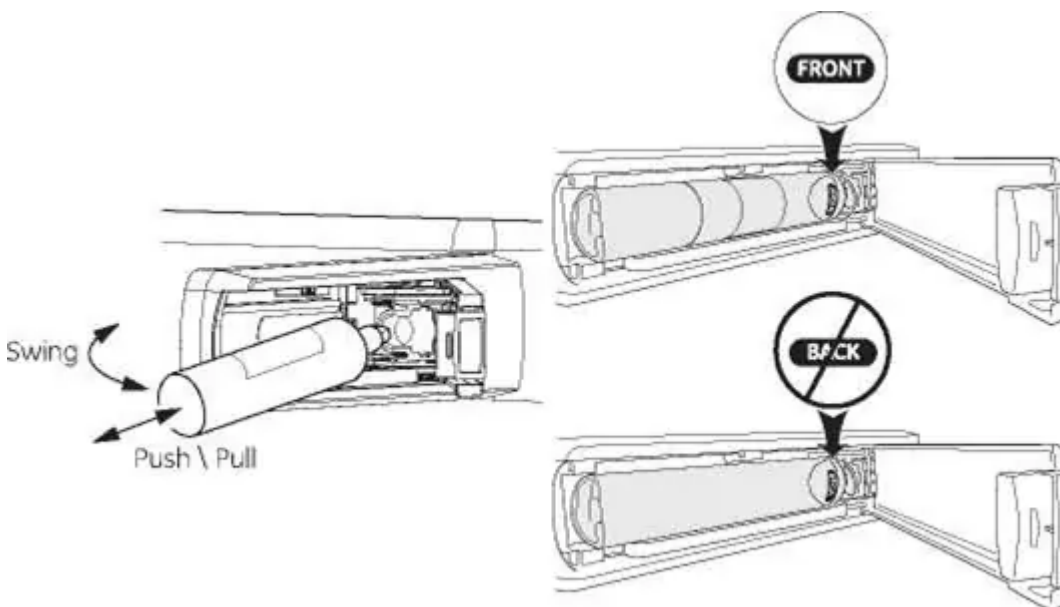

3. Run two gallons of water through the cold water dispenser (about 5 minutes) to remove air from the system. **A newly installed filter cartridge will cause water to spurt from the dispenser.** Use a large pitcher or sports bottle to catch the water spray. **DO NOT** use hands-free auto-fill (some models) until all air is removed from the system.

4. Reset Filter Status message (non-touch screen models).

**Note:** It is normal for water to appear discolored during the initial system flush. Water color will return to normal after first few minutes of dispensing.

## Filter Bypass Plug

To reduce the risk of property damage due to water leakage, you **MUST** use the filter bypass plug when a replacement filter cartridge is not available. Some models do not come equipped with the filter bypass plug. The dispenser and icemaker will not operate without either the filter or bypass plug installed. The bypass plug is installed in the same way as a filter cartridge.

## Fresh Food Storage Options

### Rearranging the Shelves

Shelves in the refrigerator compartment are adjustable.

To remove the shelves:

1. Remove all items from the shelf.
2. Tilt the shelf up at the front.
3. Lift the shelf up at the back and bring the shelf out.

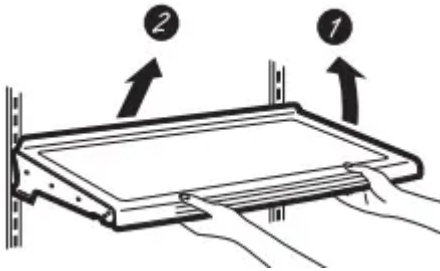

To replace:

1. While tilting the shelf up, insert the top hook at the back of the shelf in a slot on the track.
2. Lower the front of the shelf until the bottom of the shelf locks into place.

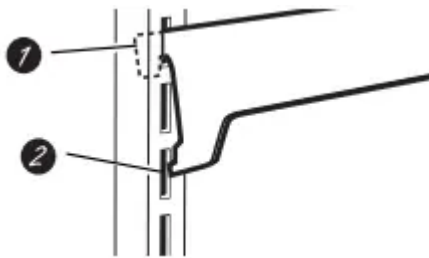

### Spillproof Shelves

Spillproof shelves have special edges to help prevent spills from dripping to lower shelves.

### Quick Space Shelf \*

This shelf splits in half and slides under itself for storage of tall items on the shelf below. This shelf can be removed and replaced or relocated

NOTE: The back half of the Quick Space Shelf is not adjustable

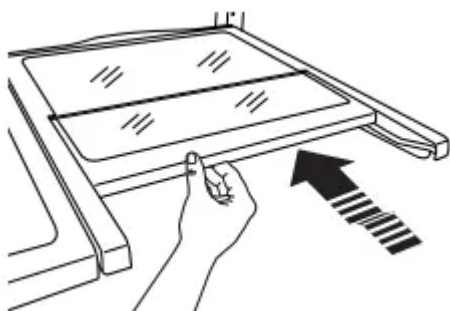

### Non-Adjustable Dairy Bin\*

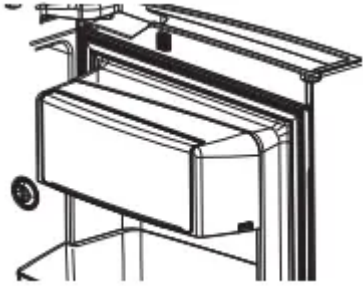

To remove: Lift the dairy bin straight up, then pull out.

To replace: Engage the bin in the molded door supports and push down. The bin will lock in place.

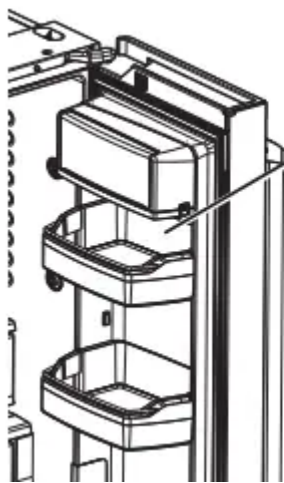

### *Adjustable Bins on the Door*

Adjustable bins can easily be carried from refrigerator to work area.

To remove: Lift bin straight up, then pull out.

To replace or relocate: Slide in the bin just above the molded door supports, and push down. The bin will lock in place. See page 33.

### Drop down tray \* (tray open)



1. Open right fresh food door
2. Depress both buttons on lower sides of bin and bin will drop down.
3. Reverse to reinstall.

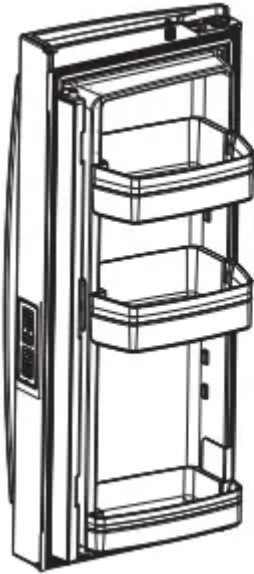

**Non-Dispense Models  
(Left Hand Door)**

**Non-Adjustable Bins on the Door (Dispenser Models - Left Hand Door)**

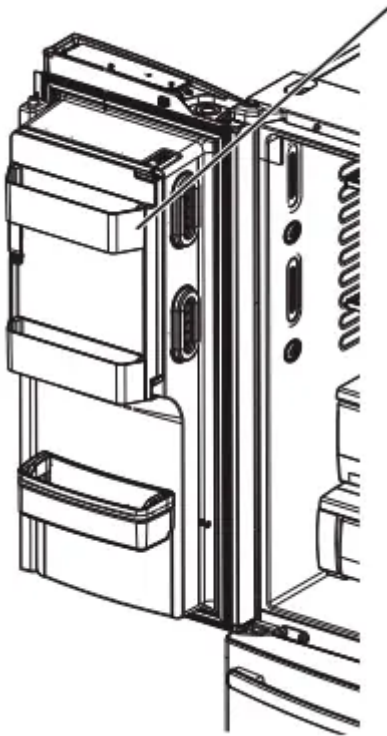

To remove: Lift the bin straight up, then pull out.

To replace: Engage the bin in the molded supports on the door and push down. It will lock in place.

The ice maker door bins are not interchangeable, note the location upon removal and replace the bin in its proper location.

## Climate Zone & Temperature Controlled Drawer

### ClimateZone

Keep fruits and vegetables organized in separate compartments for easy access.

Excess water that may accumulate in the bottom of the drawers or under the drawers should be wiped dry.

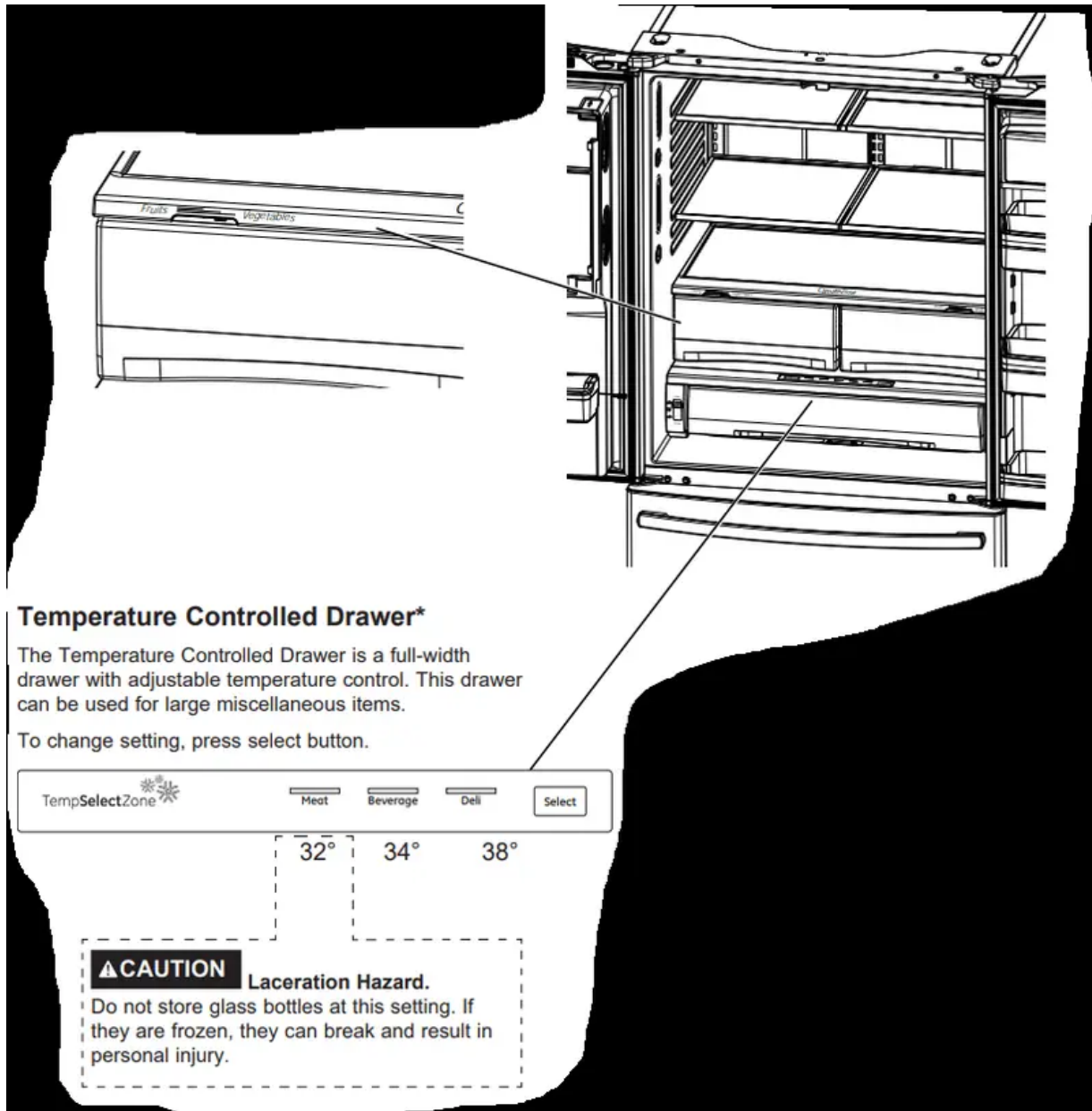

**Note:** Temperatures indicate the appropriate temperatures for the food and actual temperatures may vary based on normal operation and other factors such as door openings and fresh food set point.

### How to Remove and Replacethe Adjustable Deli/Produce Drawer

To remove:

1. Pull the pan out to the stop position.

2. Lift the front of the drawer up and out.

To replace:

1. Pull left and right slides until fully extended.

2. Place drawer back in first and rotate drawer front down to seat on slide.

3. Push the drawer in to closed position.

### **How to Remove and Replace Drawer Divider**

To remove:

1. Pull the drawer out to the stop position.

2. Raise the front side of the divider to unhook it from the rear wall of the drawer.

To replace:

1. Hook the back of the divider over the rear wall of the drawer.

2. Push the divider

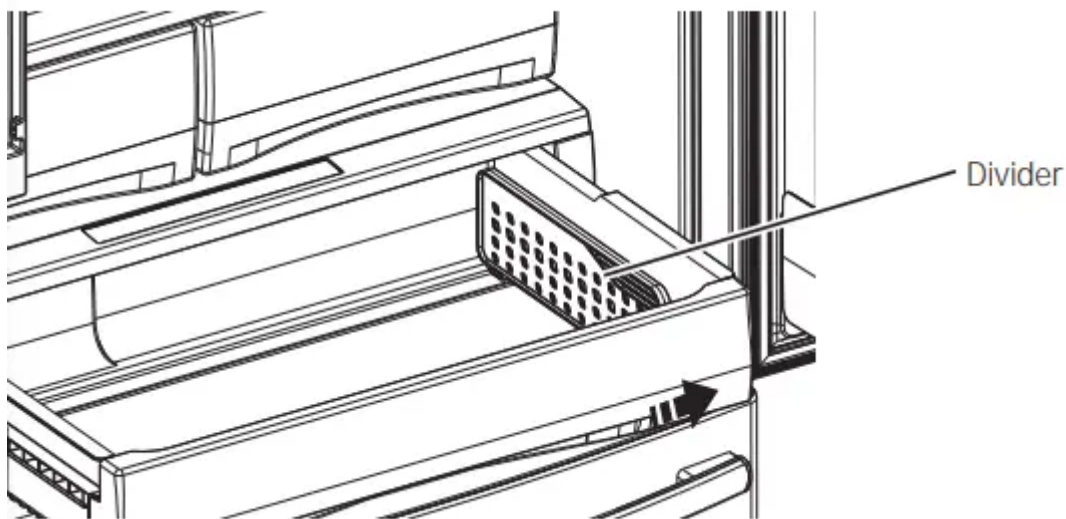

### **About the freezer.**

#### **Freezer Basket and Drawer**

1. Basket.
2. Drawer
3. Ice Bucket \*

#### **Non-Adjustable Bin in the Freezer\***

To remove:

Push in plastic tab on either left or right side

To replace:

Slide bin into location until it locks into place.

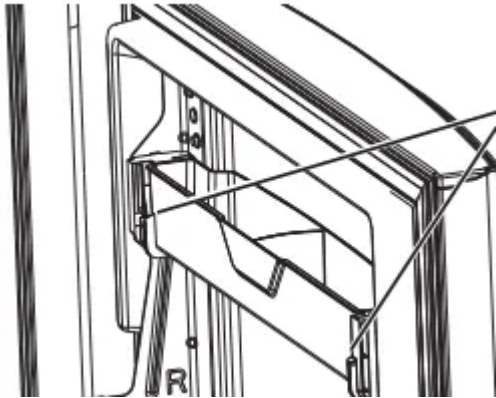

### **Basket Removal**

To remove, standard depth models only:

1. Open freezer door to the stop position.
2. Remove freezer door bin by pushing plastic tab on either left or right side to release bin hinge pin.
3. Remove freezer basket by lifting up the rear of the basket and moving basket rearward until the front of the basket can be rotated upward and out.
4. Lift it out to remove.

To remove, PYE and PWE models only:

1. Open fresh food doors.
2. Open freezer door to the stop position.
3. Remove freezer basket by lifting up the rear of the basket and rotate it upward.
4. Lift it out to remove.

To replace:

Reverse step 1 through 4 to replace.

### **Automatic Ice Maker**

A newly installed refrigerator may take 12 to 24 hours to begin making ice.

#### **Automatic Icemaker**

The ice maker will produce seven cubes per cycle approximately 100-130 cubes in a 24-hour period, depending on freezer compartment temperature, room temperature, number of door openings and other use conditions.

The ice maker will fill with water when it cools to 15°F (-10°C). A newly installed refrigerator may take 12 to 24 hours to begin making ice cubes.

If the refrigerator is operated before the water line connection is made to the unit or if the water supply to an operating refrigerator is turned off, make sure that the ice maker is turned off. Once the water has been connected to the refrigerator, the ice maker may be turned on. See the table below for details.

You may hear a buzzing sound each time the ice maker fills with water.

Throw away the first few batches of ice to allow the water line to clear.

Be sure nothing interferes with the sweep of the feeler arm.

When the bin fills to the level of the feeler arm, the ice maker will stop producing ice. It is normal for several cubes to be joined together.

If ice is not used frequently, old ice cubes will become cloudy, taste stale and shrink.

**NOTE:** In homes with lower-than-average water pressure, you may hear the ice maker cycle multiple times when making one batch of ice.

How to Turn the Ice Maker On/Off

Display Type (See Page 6)	Model #	How to turn the ice maker on/off
Control Style A	PFE28, PYE22P	Use the settings menu on the touchscreen
Control Style B	GFE28/26, DFE28, GYE22	Use the "ICE MAKER" button on the control
Control Style C	GNE29, PWE23	Use the "ICE MAKER" button on the control

**Ice Bucket and Dispenser\***

- Open the ice box door on inside of the left door.
- Pull up and out on on the ice bucket in the left hand door to remove it from the compartment.
- To replace the ice bucket, set it on the guide brackets and push until the ice bucket seats properly.
- If bucket cannot be replaced, rotate the ice bucket fork 1/4 turn clockwise.



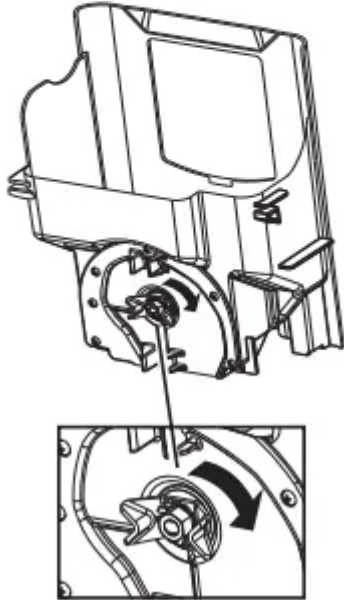
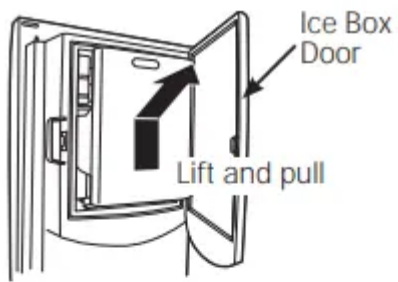

### Extra Ice Storage\*

There is additional ice storage in the freezer compartment drawer.

- Open the freezer drawer.
- The ice bucket is located on the left side of the upper basket.
- Pull the upper basket forward to remove the ice bucket.

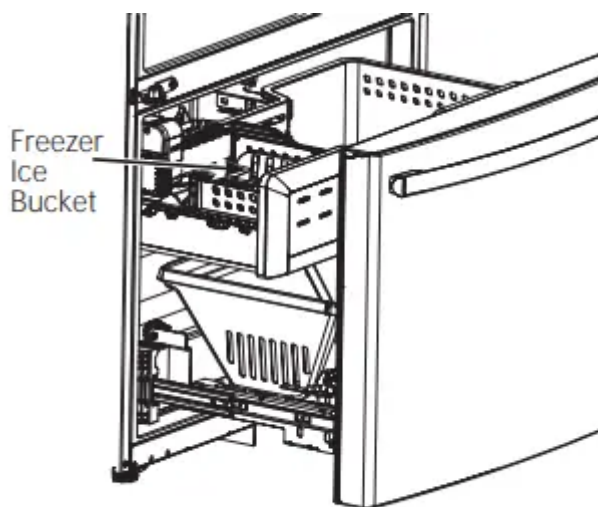

\*Select Models Only

# Care and Cleaning

## Cleaning the Outside

### **The stainless steel panels, door handles and trim.**

The stainless steel doors and door handles (on some models) can be cleaned with a commercially available stainless steel cleaner. Cleaners with oxalic acid such as Bar Keepers Friend Soft Cleanser™ will remove surface rust, tarnish and small blemishes. Use only a liquid cleanser free of grit and rub in the direction of the brush lines with a damp soft sponge. Do not use appliance wax or polish on the stainless steel.

### **Silver-accented plastic parts.**

Wash parts with soap or other mild detergents. Wipe clean with a sponge, damp cloth or paper towel.

Do not use scouring pads, powdered cleaners, bleach or cleaners containing bleach because these products can scratch and weaken the paint finish.

### **Should spill tray need cleaning use lime remover.**

## Cleaning the Inside

**To help prevent odors,** leave an open box of baking soda in the refrigerator and freezer compartments.

### **Unplug the refrigerator before cleaning.**

If this is not practical, wring excess moisture out of sponge or cloth when cleaning around switches, lights or controls.

Use an appliance wax polish on the inside surface between the doors.

Use warm water and baking soda solution—about a tablespoon (15 ml) of baking soda to a quart (1 liter) of water. This both cleans and neutralizes odors.

Rinse and wipe dry.

### **CAUTION:**

Do not clean glass shelves or covers with warm water when they are cold. Glass shelves and covers may break if exposed to sudden temperature changes or impact such as bumping or dropping. Tempered glass is designed to shatter into many small pieces if it breaks.

Do not wash any plastic refrigerator parts in the dishwasher.

## Behind the Refrigerator

Be careful when moving the refrigerator away from the wall. All types of floor coverings can be damaged, particularly cushioned coverings and those with embossed surfaces.

Raise the leveling legs located at the bottom front of the refrigerator.

Pull the refrigerator straight out and return it to position by pushing it straight in. Moving the refrigerator in a side direction may result in damage to the floor covering or refrigerator.

Lower the leveling legs until they touch the floor.

**When pushing the refrigerator back, make sure you don't roll over the power cord or water supply line.**

## **Preparing for Vacation**

For long vacations or absences, remove food and unplug the refrigerator. Clean the interior with a baking soda solution of one tablespoon (15 ml) of baking soda to one quart (1 liter) of water. Leave the doors open.

**LCD Models:** turn refrigerator off at control

If the temperature can drop below freezing, have a qualified service technician drain the water supply system to prevent serious property damage due to flooding.

- 1) Turn refrigerator off or unplug the refrigerator.
- 2) Empty ice bucket
- 3) Turn water supply off

**If you cut the water supply off, turn off the ice maker**

Upon returning from vacation:

- 1) Replace the water filter.
- 2) Run 2 gallons of water through the cold water dispenser (about 5 minutes) to flush the system.

## **Preparing to Move**

Secure all loose items such as shelves and drawers by taping them securely in place to prevent damage.

When using a hand truck to move the refrigerator, do not rest the front or back of the refrigerator against the hand truck. This could damage the refrigerator.

Handle only from the sides of the refrigerator.

**Be sure the refrigerator stays in an upright position during moving.**

## **Replacing the Lights**

### **Refrigerator Lights (LEDs)**

There is LED lighting in fresh food compartment and on the bottom of the fresh food doors to light the freezer compartment.\*

An authorized technician will need to replace the LED light.

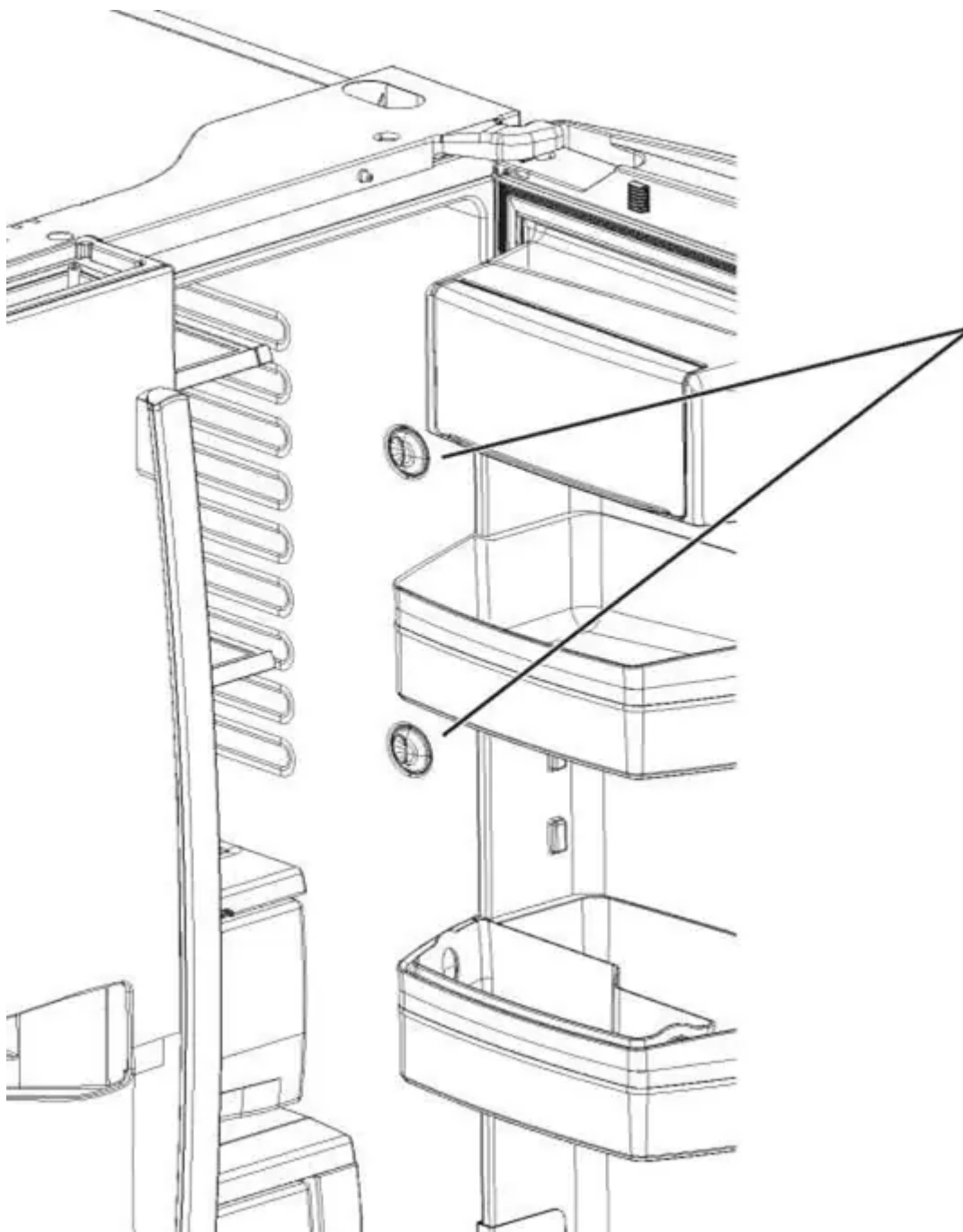

## TROUBLESHOOTING TIPS

### Normal Operating Conditions.

Newer refrigerators sound different from older refrigerators

Modern refrigerators have more features and use newer technology

**Do you hear what I hear? These conditions are normal.**

- The new high efficiency compressor may run faster and longer than your old refrigerator and you may hear a high-pitched hum or pulsating sound while it is operating.
- You may hear a whooshing sound when the doors close. This is due to pressure equalizing within the refrigerator.

### **CLICKS, POPS, CRACKS and SNAPS**

- You may hear cracking or popping sounds when the refrigerator is first plugged in. This happens as the refrigerator cools to the correct temperature.
- Expansion and contraction of cooling coils during and after defrost can cause a cracking or popping sound.
- On models with an icemaker, after an ice making cycle, you may hear the ice cubes dropping into the ice bucket.
- On models with a dispenser, during water dispense, weder you may hear the water lines move at initial dispense and after dispenser button is released.
- You may hear the fans spinning at high speeds. This happens when the refrigerator is first plugged in, when the doors are opened frequently or when a large amount of food is added to the refrigerator or freezer compartments. The fans are helping to maintain the correct temperatures.
- The fans change speeds in order to provide optimal cooling and energy savings.

### **WATER SOUNDS**

- The flow of refrigerant through the cooling coils may make a gurgling noise like boiling water.
- Water dropping on the defrost heater can cause a sizzling, popping or buzzing sound during the defrost cycle.
- A water dripping noise may occur during the defrost cycle as ice melts from the evaporator and flows into the drain pan.
- Closing the door may cause a gurgling sound due to pressure equalization.

### **START UP COOLING**

It can take up to 24 hours for the refrigerator and freezer temperatures to match the display. During that time refrigerator and freezer door openings should be minimized.

### **TIPS**

- Freezer cools first.

Refrigerator compartment cools last; it may take several hours after the freezer.

Turning off ice maker makes both fresh food and freezer food cool faster.

Problem	Possible Causes	What to Do
Water filter indicated as installed incorrectly or a leak is present on LCD screen.	Water filter installed backward or is leaking.	Check for leak. If no leak is present, remove filter/bypass plug, rotate 180 degrees and reinstall.
Water filter indicator light remains lit after replacing filter	Filter timer has not been reset or filter is installed backward.	<p><b>Internal Dispense models:</b></p> <ul style="list-style-type: none"> <li>-Press and hold reset button for 3 seconds</li> </ul> <p><b>External Dispense models:</b></p> <ul style="list-style-type: none"> <li>-Remove filter and rotate 180 degrees and reinstall.</li> </ul>
Water filter indicator light is not lit	This is normal. This indicator will turn on to tell you that you need to replace the filter soon.	See <b>About the Water Filter</b> for more information.
Handle is loose/handle has a gap.	Handle needs adjusting	See <b>Attach Fresh Food Handle</b> and <b>Attach the Freezer Handle</b> sections for detailed instructions.
Refrigerator beeping	This is door alarm	-Turn off or disable with door closed. When door is open and alarm is sounding, you can only snooze the alarm
Not cooling	The cooling system is off	See <b>About Controls</b> .
Water has poor taste/odor*	Water dispenser has not been used for a long time	Dispense water, until all water in system is replenished.
Water in glass is warm*	Normal when refrigerator is first installed	Wait 24 hours for the refrigerator to completely cool down.
	Water dispenser has not been used for a long time	Dispense water, until all water in system is replenished
	Water system has drained	



		Allow several hours for replenished supply to chill
Water dispenser does not work*	Water supply line turned off or not connected	See <b>Installing the Water Line</b>
	Water filter clogged or filter/bypass plug not installed	Replace filter cartridge or remove and install bypass plug**
	Air may be trapped in the water system	Press the dispenser arm for at least 5 minutes.
	Water in reservoir is frozen because the controls are set too cold	Set the refrigerator control to a warmer setting and wait 24 hours. If the water does not dispense after 24 hours, call for service
Water spurting from dispenser*	Newly installed filter cartridge	Run water from the dispenser for 5 minutes (about 2 gallons)
No water or ice cube production*	Supply line or shutoff valve is clogged	Call a plumber
	Water filter is clogged	Replace filter cartridge or remove and install bypass plug**
	Filter cartridge not properly installed	Remove and reinstall filter cartridge, being certain that it locks in place.
	Ice maker is turned off	Check that the ice maker is turned on. See <b>About the Automatic Ice Maker.</b>
Water is leaking from dispenser*	Air may be present in the water line system, causing water to drip after being dispensed	Dispense water for at least 5 minutes to remove air from system



Photos not found*	Photos not in root directory of USB Photos not in JPEG format Camera/ PC used with USB cord	Make sure the photos are in the root directory in your USB Photos must be in JPEG format Must use a USB drive
<b>AUTO FILL</b> under fill/no fill*	Not all containers work with <b>AUTO FILL</b>	Try different container
	<ul style="list-style-type: none"> <li>• Container not found</li> <li>• Unstable container</li> <li>• Misaligned container</li> </ul>	
<b>AUTO FILL</b> overfills*	Not all containers work with <b>AUTO FILL</b>	Try different container
<b>PRECISE FILL</b> will not fill container*	Normal, <b>PRECISE FILL</b> requires use of dispenser paddle	For a specific amount of water, select <b>PRECISE FILL</b> to dispense water
Freezer cooling, fresh food not cooling	Normal, when refrigerator first plugged in or after extended power outage	Wait 24 hours for temperature in both compartments to reach selected temperatures.
Ice dispenser opens after closing freezer drawer *	Normal	The ice dispenser door may open when closing freezer door to allow access



## Truth or Myth

Truth or Myth?	Answer	Explanation
The refrigerator water filter may require replacement prior to six months	TRUE	The water filter indicator will indicate the need to replace the water filter every six months or 170 gallons of water dispensed (select models only). Water quality varies by location to city. If water flow from the dispenser slows, or ice production decreases, the water filter should be replaced, even though the filter indicator may not indicate the need for replacement.
The automatic ice maker in my refrigerator will produce ice when the refrigerator is plugged in to a power receptacle.	MYTH	The refrigerator must be connected to water, and the ice maker must be turned on. Make sure the ice maker is turned on, only after the water line is connected and water is flowing. The ice maker can be turned <b>on/ off</b> from the control panel. To ensure the ice maker is on, as indicated on the refrigerator control panel. See About the Automatic Ice Maker.
After the refrigerator has been plugged in and connected to water, I will immediately have unlimited chilled water available from the water dispenser.	MYTH	The water dispenser tank located inside the refrigerator requires time for the water to chill after installation. High usage conditions will require more time for the water to chill.
After water dispenses, a few drops of water are normal.	TRUE	A few drops of water may fall from the dispenser, after the dispenser paddle has been released. To minimize this, remove the glass slowly from the dispenser.
I will never see frost inside the freezer compartment.	MYTH	Frost inside the freezer typically indicates that the door is not properly sealed, or has been left open. If frost is found, remove the frost using a plastic spatula and towel, then check the door seal. Ensure that no food packages or containers are preventing the freezer door from closing. Check the refrigerator control panel to ensure the door alarm is on.
When the refrigerator is installed, or after replacing the water filter, I must dispense water for five minutes.	TRUE	A newly installed refrigerator or water filter contains air in the water lines. Press the dispenser paddle and dispense water for at least 5 minutes to remove air from the lines and flush the filter.



<p>To fill the ice bucket to the maximum capacity, I should dispense 12 and 18 hours after installation.</p>	<p>TRUE</p>	<p>Dispensing 3-4 cubes 12 hours and 18 hours after installation allows ice to disperse within the ice bucket, which calls on the ice maker to produce additional ice. Ice production = 100 cubes in 24 hours.</p>
<p>I can use the water filter bypass plug to determine if the filter requires replacement.</p>	<p>TRUE</p>	<p>Decrease in flow from the water dispenser, or decrease in ice production, may indicate the need to replace the water filter. Install the water filter bypass plug (provided with the refrigerator on some models*), and check flow from the water dispenser. If water flow returns to normal with the bypass plug in place, replace the water filter.</p>
<p>The top of the refrigerator doors will always be aligned.</p>	<p>MYTH</p>	<p>Several things can affect the fresh food door alignment, including the floor the refrigerator is installed on and the level of doors. If the top of the fresh food doors are not aligned, use a 1/4" allen wrench to adjust the right/left hand door. The adjustment screw is located on the bottom right or left side of the door; open the freezer door to access the adjustment screw.</p>
<p>Refrigerator door handles can be easily tightened.</p>	<p>TRUE</p>	<p>If door handles are loose or have a gap, the handles can be adjusted using a 1/8" allen wrench, on set screws located at the ends of the handles.</p>
<p>There may be odor and taste problems with your ice.</p>	<p>TRUE</p>	<p>After starting the ice maker throw away 24 hours of ice production to avoid odor and taste problems.</p>
<p>I can make fine adjustments to the fresh food doors to align them.</p>	<p>TRUE</p>	<p>If the fresh food doors are not aligned, use a 1/4" Allen wrench to adjust the right hand door. The adjustment screw is located on the bottom of the right/left hand door. Open the freezer door to access.</p>
<p>Door handles should always be removed for installation.</p>	<p>MYTH</p>	<p>Check chart on reverse side of this instruction. If the handles must be removed do not remove the handles, or if they do not fit the refrigerator will fit easily through the passage way of the cabinet. Adjust handles that are loose or have a gap, by adjusting the set screws on either end of handles.</p>
	<p>MYTH</p>	



Door removal is always required for installation.		Check chart on reverse side of this instruction. Door may only be removed when necessary to prevent damage to passage way or access to final location.
Refrigerator doors that won't close after installation, can be adjusted to close properly.	TRUE	Door mechanism works best if installed at 90°. If in 180°, remove the door from the mid hinge, and swing to 180° before reinstalling. See Reinstalling the Refrigerator Doors.
There is an adjustment to rear wheels.	MYTH	Front leveling legs are adjustable and should be used to balance the refrigerator. Leveling legs are used to make fresh food door adjustment.
Check for leaks after all water connections are made.	TRUE	While purging the air from the water system, check all line connections for leaks. Check the connection to household water supply at back of refrigerator, and to line connect.
My LCD display will always be on when I plug the power cord in at installation.	MYTH	If the refrigerator has been stored in a cold environment, LCD may be slow to give a proper display. Give the refrigerator enough time to warm up, and the display should be okay.
Any packaging residue can be cleaned off the refrigerator using any cleaner.	MYTH	Do not use wax, polish, bleach, or other products containing chlorine on Stainless Steel panels, door handles and trim. Check this instruction under "Cleaning the Outside" for details.

### Warning

This content is compiled from multiple sources and is provided for reference purposes only. It may not be complete or fully applicable to all situations. If you are unable to resolve your issue, please contact the product manufacturer or an authorized service provider for official support.

