

Operation Guide

Instruments

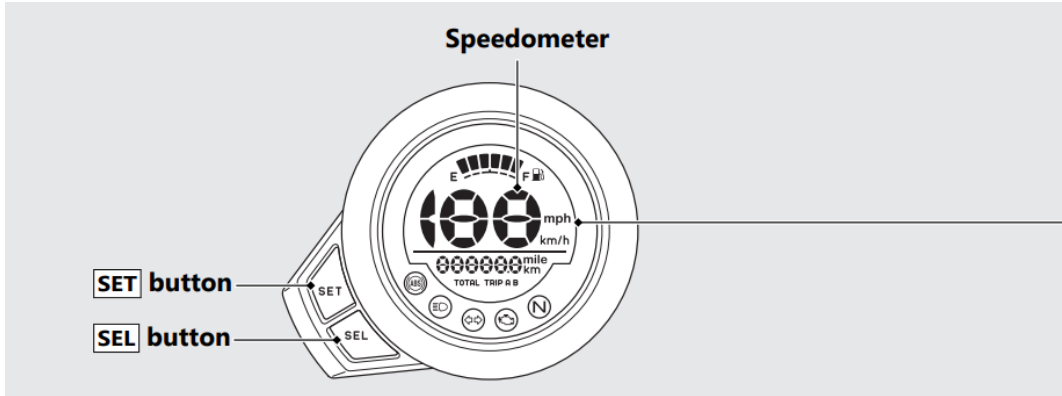

Display Check

When the ignition switch is turned to the ON position, all the mode and digital segments will show.

If any part of these displays does not come on when it should, have your dealer check for problems.

Fuel gauge
Remaining fuel when only 1st (E) segment starts flashing:
approximately 0.476 US gal (1.80 L)
If the fuel gauge indicator flashes in a repeat pattern or turns off: ➔ P.71

Odometer [TOTAL] & Tripmeter [TRIP A/B]
SEL button switches between the odometer and tripmeters.

- Odometer: Total distance ridden.
- Tripmeter: Distance ridden since tripmeter was reset (press and hold the **SET** button to reset to 0.0 km/mile).

Changing of speed and mileage unit

1. Turn the ignition switch to the ON position.
2. Press and hold **SEL** button and **SET** button.

3. Press **SEL** button to select either “km/h” and “km” or “mph” and “mile”.

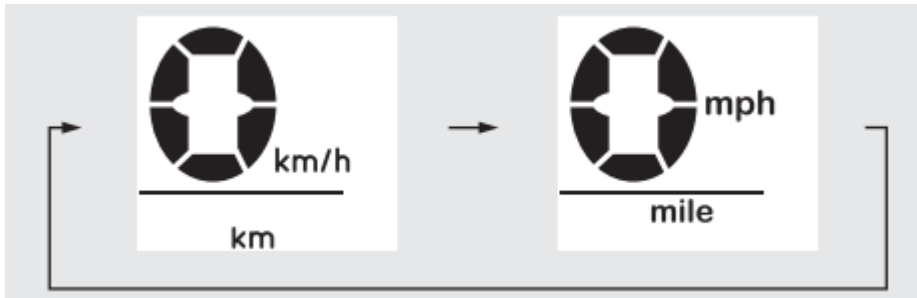

4. Press **SET** button. The speed and mileage unit is set, and then the display returns to the ordinary display

Starting the Engine

Start your engine using the following procedure, regardless of whether the engine is cold or warm.

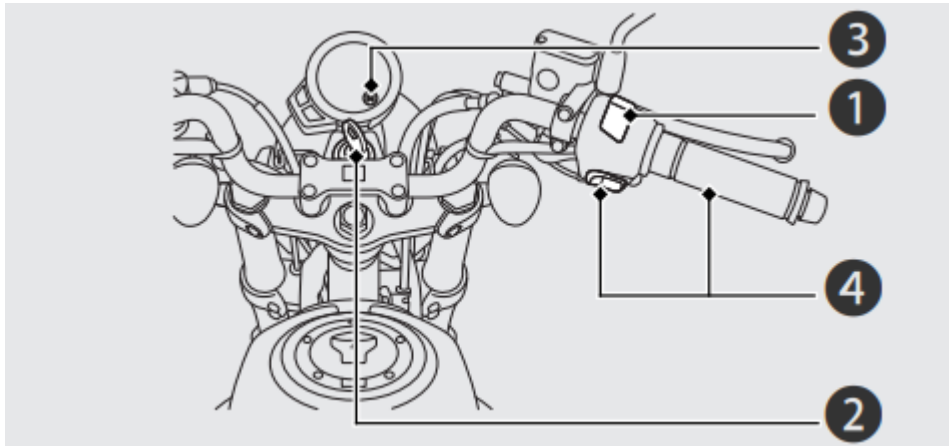

Consult your dealer for advice if you plan to ride your vehicle at an altitude above 8,000 feet (2,500 m).

1. Make sure the engine stop switch is in the  (Run) position.
2. Turn the ignition switch to the ON position.
3. Shift the transmission to Neutral (**N** indicator to come on). Alternatively, pull in the clutch lever to start your vehicle with the transmission in gear so long as the side stand is raised.
4. Press the start button with the throttle completely closed.

About 0.1 in (3 mm), without freeplay

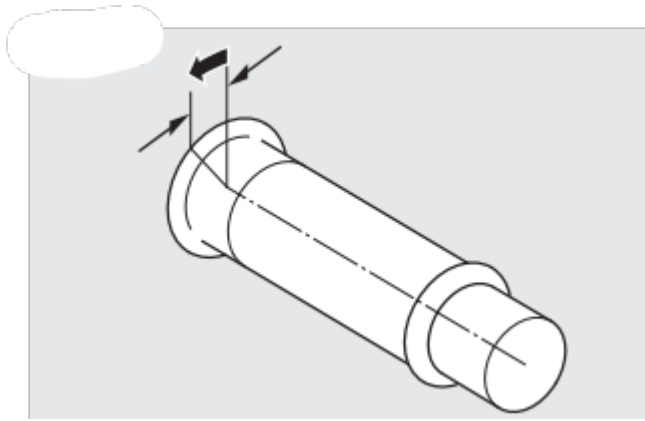

If the engine does not start:

1. Open the throttle fully and press the start button for 5 seconds.
2. Repeat the normal starting procedure.
3. If the engine starts, open the throttle slightly if idling is unstable.
4. If the engine does not start, wait 10 seconds before trying step 1 & 2 again.

Refueling

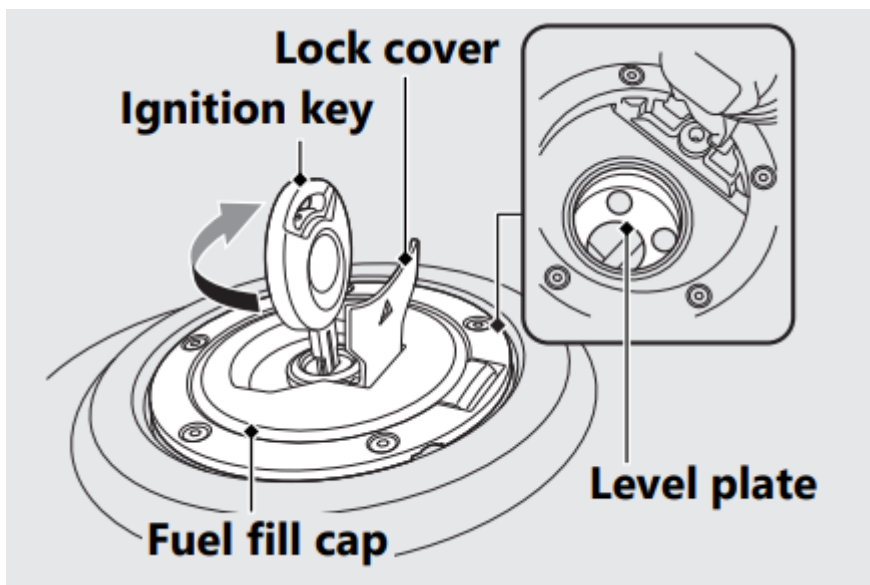

Do not fill with fuel above the level plate.

Fuel type: Unleaded gasoline only

Recommended fuel octane number: Pump Octane Number (PON) 86 or higher.

Tank capacity: 1.48 US gal (5.6 L)

Opening the Fuel Fill Cap

Open the lock cover, insert the ignition key, and turn it clockwise to open the fuel fill cap.

Closing the Fuel Fill Cap

1. After refueling, push the fuel fill cap until it locks.
2. Remove the ignition key and close the lock cover.

The ignition key cannot be removed if the fuel fill cap is not locked

Maintenance

Importance of Maintenance

Keeping your vehicle well-maintained is absolutely essential to your safety and to protect your investment, obtain maximum performance, avoid breakdowns, and reduce air pollution. Maintenance is the owner's responsibility. Be sure to inspect your vehicle before each ride, and perform the periodic checks specified in the Maintenance Schedule.

For information about the exhaust emission and noise emission requirements of the U.S. Environmental Protection Agency (EPA), and the California Air Resources Board (CARB).

Maintenance Safety

Always read the maintenance instructions before you begin each task, and make sure that you have the tools, parts, and skills required. We cannot warn you of every conceivable hazard that can arise in performing maintenance. Only you can decide whether or not you should perform a given task.

Follow these guidelines when performing maintenance.

- Stop the engine and remove the key.
- Place your vehicle on a firm, level surface using the side stand or a maintenance stand to provide support.
- Allow the engine, muffler, brakes, and other high-temperature parts to cool before servicing as you can get burned.
- Run the engine only when instructed, and do so in a well-ventilated area.

The maintenance schedule specifies the maintenance requirements necessary to ensure safe, dependable performance, and proper emission control.

Maintenance work should be performed in accordance with Honda's standards and specifications by properly trained and equipped technicians. Your dealer meets all of these requirements. All scheduled maintenance is considered a normal owner operating cost and will be charged to you by your dealer. Keeping an accurate maintenance record will help ensure your vehicle is properly maintained.





Make sure whoever performs the scheduled maintenance completes the maintenance record. Retain all service documents. If you sell your vehicle, these service documents should be transferred with the vehicle to the new owner.

| Items | Frequency *1 | | | | | | | | Regular Replace | Refer to page |
|--|--------------|-----|-----|------|------|------|------|------|-----------------|---------------|
| | × 1,000 mi | 0.6 | 4 | 8 | 12 | 16 | 20 | 24 | | |
| | × 1,000 km | 1.0 | 6.4 | 12.8 | 19.2 | 25.6 | 32.0 | 38.4 | | |
| Fuel Line | | | I | I | I | I | I | I | | - |
| Throttle Operation | | | I | I | I | I | I | I | | 66 |
| Air Cleaner *2 | | | | | R | | | R | | - |
| Crankcase Breather *3 | | | C | C | C | C | C | C | | - |
| Spark Plug | | | I | R | I | R | I | R | | - |
| Valve Clearance | | | I | I | I | I | I | I | | - |
| Engine Oil | | R | R | R | R | R | R | R | 1 Year | - |
| Engine Oil Strainer Screen | | | | C | | C | | C | | - |
| Engine Oil Centrifugal Filter | | | | C | | C | | C | | - |
| Engine Idle Speed | | I | I | I | I | I | I | I | | - |
| Evaporative Emission Control System *4 | | | | | I | | | I | | - |



















































































Maintenance Level

| | |
|--|--|
| | <p>Intermediate. We recommend service by your dealer, unless you have the necessary tools and are mechanically skilled.</p> <p>Procedures are provided in an official Honda Service Manual</p> |
| | <p>Technical. In the interest of safety, have your vehicle serviced by your dealer.</p> |

Maintenance Legend

| | |
|---|--|
|  | Inspect (clean, adjust, lubricate, or replace, if necessary) |
|  | Lubricate |
|  | Replace |
|  | Clean |



| Items | Frequency *1 | | | | | | | | | Regular Replace | Refer to page |
|------------------------|---|-----|---|---|---|---|--|---|---|-----------------|---------------|
| | × 1,000 mi | 0.6 | 4 | 8 | 12 | 16 | 20 | 24 | | | |
| | × 1,000 km | 1.0 | 6.4 | 12.8 | 19.2 | 25.6 | 32.0 | 38.4 | | | |
| Drive Chain | Every 300 mi (500 km):   | | | | | | | | | | 62 |
| Brake Fluid *5 | | |  |  |  |  |  |  |  | 2 Years | 58 |
| Brake Pads Wear | | |  |  |  |  |  |  |  | | 59 |
| Brake System | | |  |  |  |  |  |  |  | | 58 |
| Brake Light Switch | | |  |  |  |  |  |  |  | | 60 |
| Headlight Aim | | |  |  |  |  |  |  |  | | - |
| Clutch System | | |  |  |  |  |  |  |  | | 63 |
| Side Stand | | |  |  |  |  |  |  |  | | 61 |
| Suspension |  | |  |  |  |  |  |  |  | | - |
| Nuts, Bolts, Fasteners |  | |  |  |  |  |  |  |  | | - |
| Wheels/Tires |  | |  |  |  |  |  |  |  | | - |
| Steering Head Bearings |  | |  |  |  |  |  |  |  | | - |

Notes:

- *1 : At higher odometer reading, repeat at the frequency interval established here.
- *2 : Service more frequently when riding in unusually wet or dusty areas.
- *3 : Service more frequently when riding in rain or at full throttle.
- *4 : 50 STATE (meets California)
- *5: Replacement requires mechanical skill.

Maintenance Fundamentals

Pre-ride Inspection

To ensure safety, it is your responsibility to perform a pre-ride inspection and make sure that any problem you find is corrected. A preride inspection is a must, not only for safety, but because having a breakdown, or even a flat tire, can be a major inconvenience.

Check the following items before you get on your vehicle:

- Tire tread wear and air pressures are within limits.
- Lights, horn, and turn signals operate normally.
- Check the condition of the drive chain. Adjust slack and lubricate as needed.

Check the following items if you are carrying a cargo:

- Combined weight is within load limits.
- Cargo is secured properly.

Check the following items after you get on your vehicle:

- Throttle action moves smoothly without binding.
- Brake lever and pedal operate normally.
- Check the fuel level and refuel when needed.
- Engine stop switch functions properly



Check the following items at regular intervals:

- Oil level is between the upper and lower level marks.
- Brake fluid level is Front: above the LOWER level mark. Rear: between the UPPER and LOWER level marks.
- Side stand functions properly.

Periodic Checks

You should also perform other periodic maintenance checks at least once a month regardless of how often you ride, or more often if you ride frequently.

Also, check the odometer reading against the Maintenance Schedule and perform all maintenance that is due

| | |
|------------------|--|
| Tires and wheels | Check the air pressure (➤ P. 47), examine tread for wear and damage (➤ P. 47), and check the wheels for damage. |
| Fluid levels | Check the engine oil level (➤ P. 56), and brake fluid level (➤ P. 58). |
| Lights | Check that the headlight, position light, brake light, taillight, turn signals and license plate light are working properly. |
| Controls | Check the freeplay of the clutch lever (➤ P. 63), and throttle grip (➤ P. 66). |
| Drive chain | Check the slack (➤ P. 62), adjust the slack, and lubricate (➤ P. 46) as needed. |
| Fuses | Check that you have a full supply of spare fuses. |
| Nuts & bolts | Check the major nuts and bolts, and tighten as needed. |

Replacing Parts

Always use Honda Genuine Parts or their equivalents to ensure reliability and safety. When ordering colored components, specify the model name, color, and code mentioned on the color label.

The color label is attached to the frame.

To check the color label, remove the left side cover.

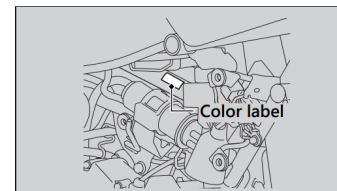

Battery

Your vehicle has a maintenance-free type battery. You do not have to check the battery electrolyte level or add distilled water. Clean the battery terminals if they become dirty or corroded.

Do not remove the battery cap seals. There is no need to remove the cap when charging.

What to do in an emergency

If any of the following occur, immediately see your doctor.

- Electrolyte splashes into your eyes:

Wash your eyes repeatedly with cool water for at least 15 minutes. Using water under pressure can damage your eyes.

- Electrolyte splashes onto your skin:

Remove affected clothing and wash your skin thoroughly using water.

- Electrolyte splashes into your mouth:

Rinse mouth thoroughly with water, and do not swallow.

Wash your hands after handling.

Cleaning the Battery Terminals

1. Remove the battery.
2. If the terminals are starting to corrode and are coated with a white substance, wash with warm water and wipe clean.
3. If the terminals are heavily corroded, clean and polish the terminals with a wire brush or sandpaper. Wear safety glasses.

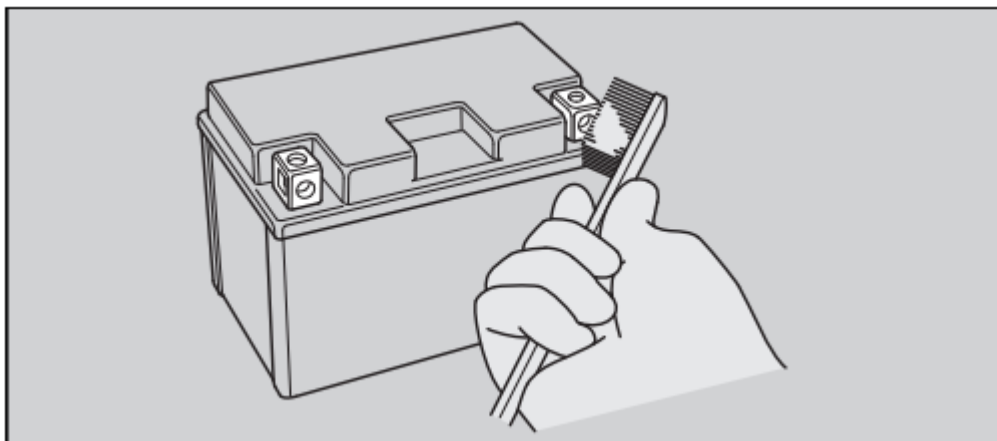

4. After cleaning, reinstall the battery.

The battery has a limited life span. Consult your dealer about when you should replace the battery. Always replace the battery with another maintenance-free battery of the same type.

Charging

If you use electrical accessories that drain the battery or you do not ride frequently, we recommend that you charge the battery every 30 days using a charger designed specifically for your Honda, which can be purchased from your dealer. Read the information that came with your battery charger and follow the instructions on the battery. Avoid using an automobile-type battery charger, as these can overheat a motorcycle battery and cause permanent damage.

Make sure the ignition switch is in the OFF position before charging the battery.

Fuses

Fuses protect the electrical circuits on your vehicle. If something electrical on your vehicle stops working, check for and replace any blown fuses.

Inspecting and Replacing Fuses

Turn the ignition switch to the OFF position to remove and inspect fuses. If a fuse is blown, replace with a fuse of the same rating. For fuse ratings, see “Specifications.”

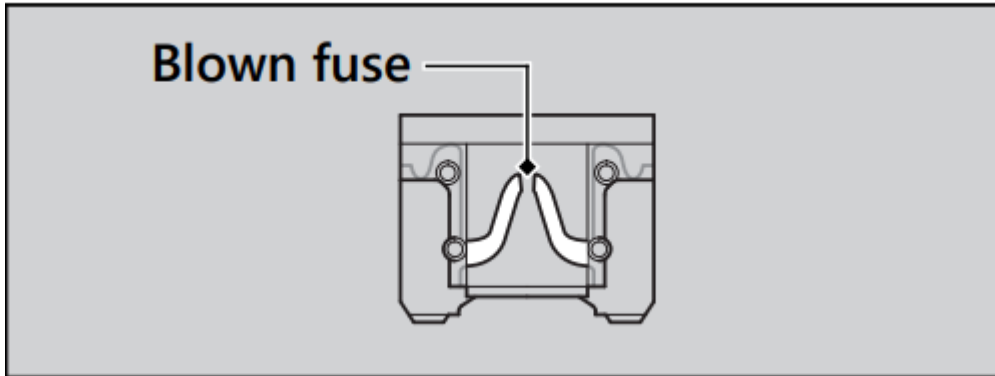

If a fuse fails repeatedly, you likely have an electrical fault. Have your vehicle inspected by your dealer.

Engine Oil

Engine oil consumption varies and oil quality deteriorates according to riding conditions and time elapsed.

Check the engine oil level regularly, and add the recommended engine oil if necessary. Dirty oil or old oil should be changed as soon as possible.

Selecting the Engine Oil

For recommended engine oil, see “Specifications.”

If you use non-Honda engine oil, check the label to make sure that the oil satisfies all of the following standards:

- JASO T 903 standard*1: MA
- SAE standard*2: 10W-30
- API classification*3: SG or higher

*1. The JASO T 903 standard is an index for engine oils for 4-stroke motorcycle engines. There are two classes: MA and MB. For example, the following label shows the MA classification.

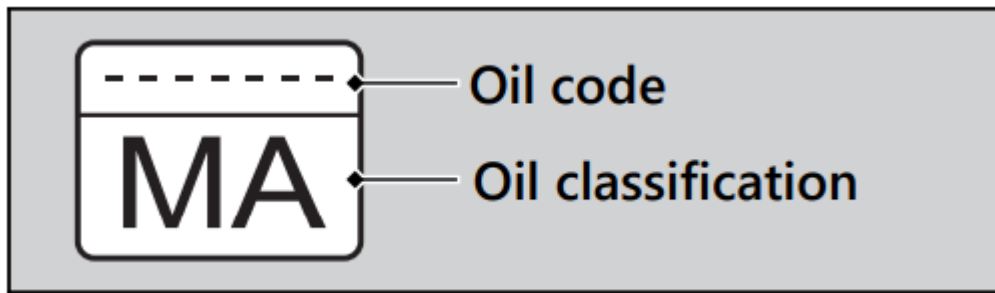

*2. The SAE standard grades oils by their viscosity.

*3. The API classification specifies the quality and performance rating of engine oils. Use SG or higher oils, excluding oils marked as “Energy Conserving” or “Resource Conserving” on the circular API service symbol.

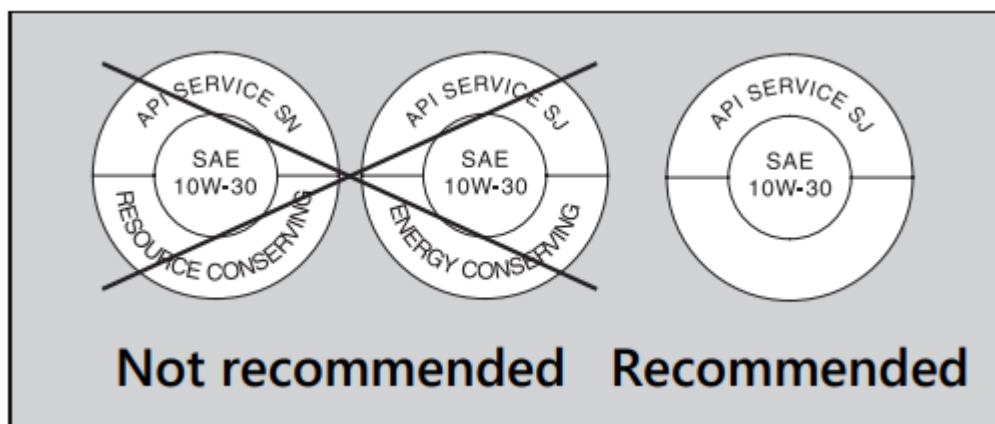

Brake Fluid

Do not add or replace brake fluid, except in an emergency. Use only fresh brake fluid from a sealed container. If you do add fluid, have the brake system serviced by your dealer as soon as possible.

Drive Chain

The drive chain must be inspected and lubricated regularly. Inspect the chain more frequently if you often ride on bad roads, ride at high speed, or ride with repeated fast acceleration.

If the chain does not move smoothly, makes strange noises, has damaged rollers, has loose pins, or kinks, have the chain inspected by your dealer.

Also inspect the drive sprocket and driven sprocket. If either has worn or damaged teeth, have the sprocket replaced by your dealer.

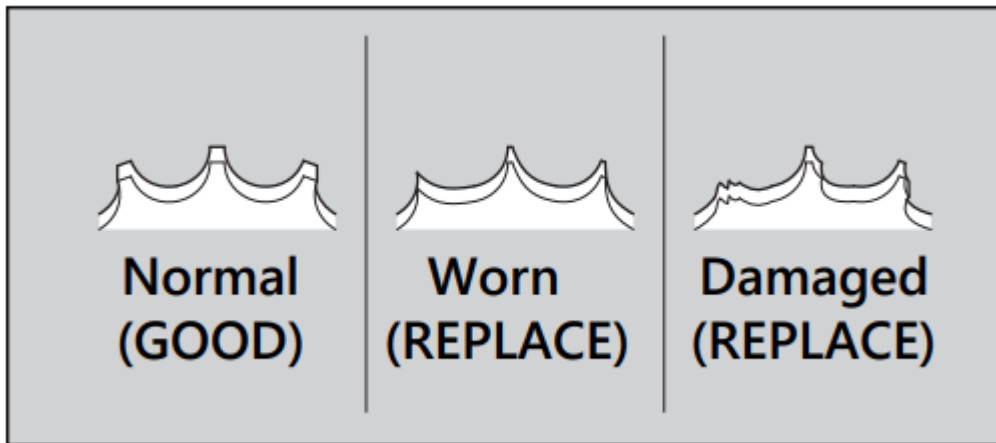

Cleaning and Lubricating

After inspecting the slack, clean the chain and sprockets while rotating the rear wheel. Use a dry cloth with high flash-point solvent. Use a soft brush if the chain is dirty.

After cleaning, wipe dry and lubricate with the recommended lubricant.

Recommended lubricant:
Pro Honda HP Chain Lube or equivalent

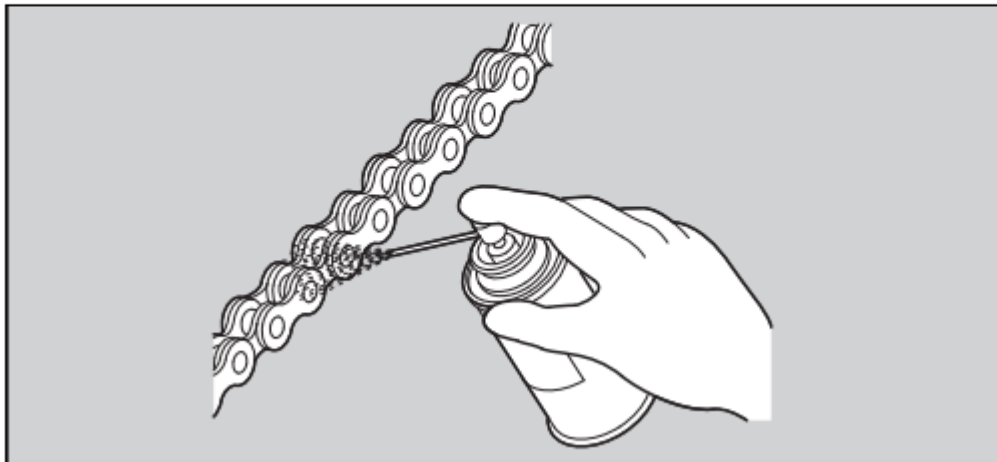

Never use gasoline or low flash point solvents for cleaning the drive chain.

A fire or explosion could result.

Avoid getting lubricant on the brakes or tires. Avoid applying excess chain lubricant to prevent spray onto your clothes and the vehicle.

Crankcase Breather

Service more frequently when riding in rain, at full throttle, or after the vehicle is washed or overturned. Service if the deposit level can be seen in the transparent section of the drain tube.

If the drain tube overflows, the air filter may become contaminated with engine oil causing poor engine performance.

Tires (Inspecting/Replacing)

Checking the Air Pressure

Visually inspect your tires and use an air pressure gauge to measure the air pressure at least once a month or any time you think the tires look low. Always check air pressure when your tires are cold.

Inspecting for Damage

Inspect the tires for cuts, slits, or cracks that exposes fabric or cords, or nails or other foreign objects embedded in the side of the tire or the tread. Also inspect for any unusual bumps or bulges in the side walls of the tires.

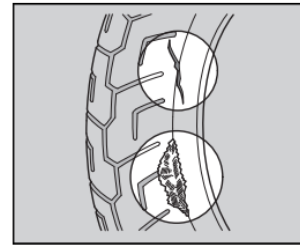

Inspecting for Abnormal Wear

Inspect the tires for signs of abnormal wear on the contact surface.

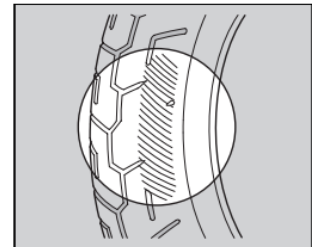

Inspecting Tread Depth

Inspect the tread wear indicators. If they become visible, replace the tires immediately

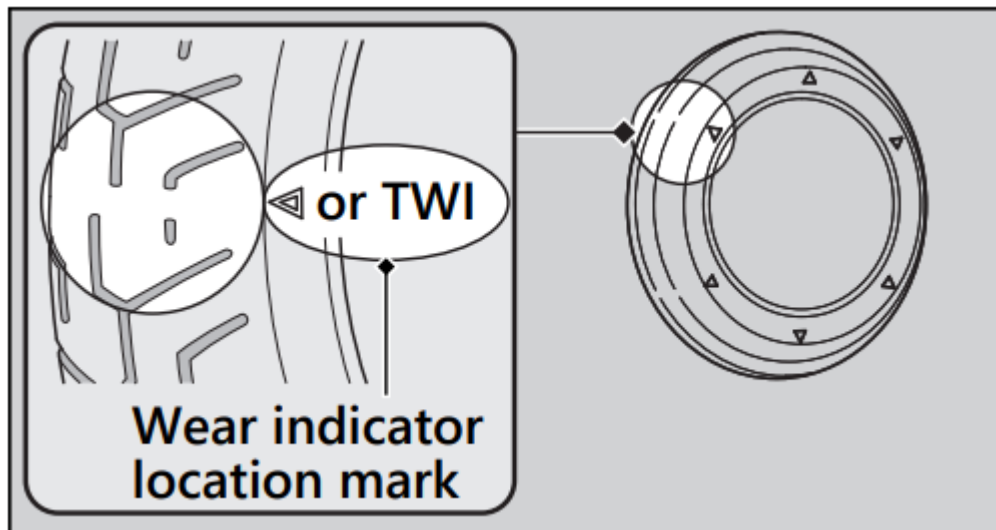

Have your tires replaced by your dealer.

For recommended tires and air pressure, see “Specifications.”

Follow these guidelines whenever you replace tires.

- Use the recommended tires or equivalents of the same size, construction, speed rating, and load range.
- Do not install a tube inside a tubeless tire on this vehicle. Excessive heat build-up can cause the tube to burst.
- Use only tubeless tires on this vehicle. The rims are designed for tubeless tires, and during hard acceleration or braking, a tubetype tire could slip on the rim and cause the tire to rapidly deflate

Tire Service Life

The service life of your tires is dependent on many factors, including, but not limited to, riding habits, road conditions, vehicle loading, tire air pressure, maintenance history, speed, and environmental conditions (even when the tires are not in use).

In addition to your regular inspections and maintenance, it is recommended that you have annual inspections performed once the tires reach 5 years old. It is also recommended that all tires be removed from service after 10 years from the date of manufacture, regardless of their condition or state of wear.

The last four digits of the TIN (tire identification number) indicate the date of manufacture.

Tire Identification Number (TIN)

The tire identification number (TIN) is a group of numbers and letters located on the sidewall of the tire

① ② ③

DOT XXXX XXXX 22 09

DOT: This indicates that the tire meets all requirements of the U.S. Department of Transportation.

① XXXX: Factory code

② XXXX: Tire type code

③ 22 09: Date of manufacture (week & year).

Example: week 22 in year 09.

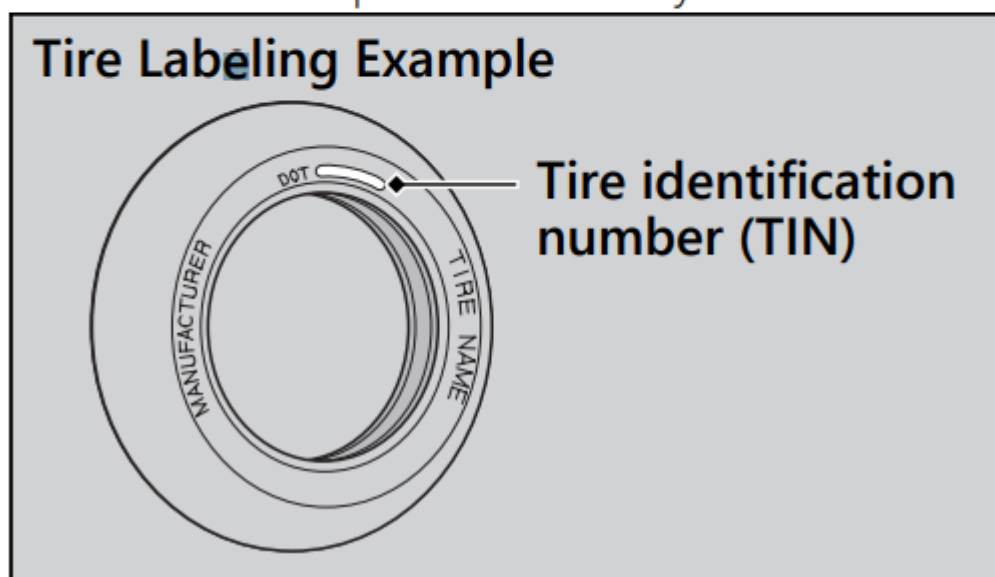

The tool kit is located behind the right side cover.

You can perform some roadside repairs, minor adjustments and parts replacement with the provided tools.

- Fuse puller
- Standard/Phillips screwdriver
- Screwdriver handle
- 6 mm Hex wrench
- Helmet set wire

Removing & Installing Body Components

Battery

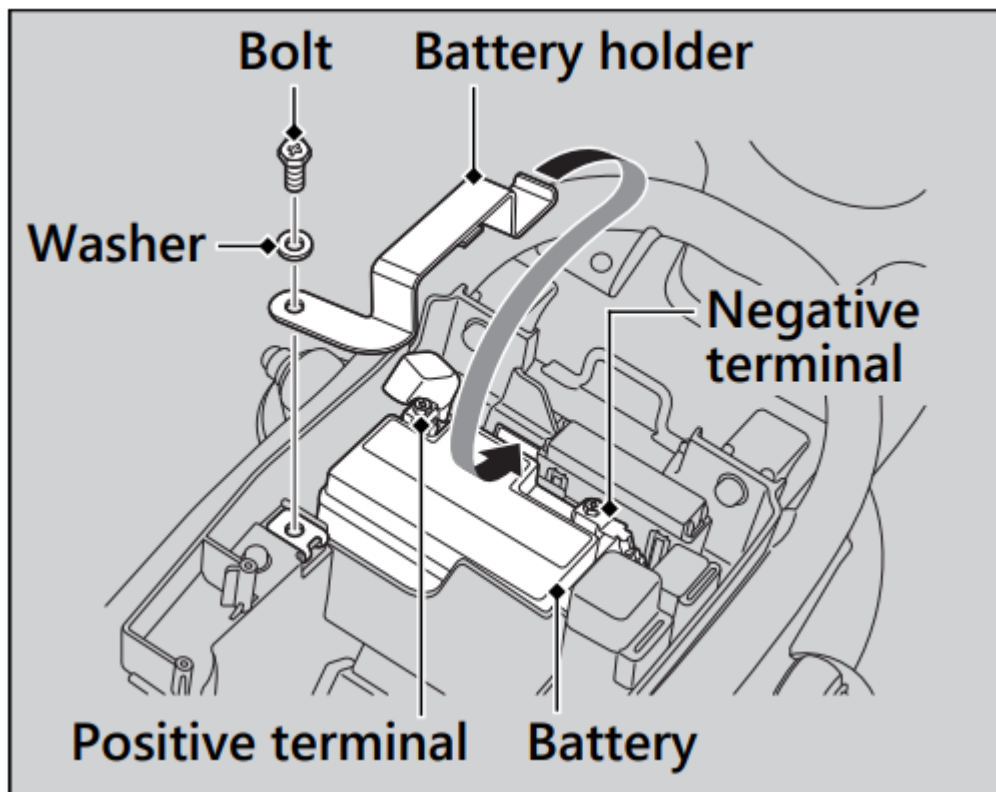

Removal

Make sure the ignition switch is in the OFF position.

1. Remove the seat
2. Remove the battery holder by removing the bolt and washer.
3. Disconnect the negative - terminal from the battery.
4. Disconnect the positive + terminal from the battery.
5. Remove the battery taking care not to drop the terminal nuts.

Installation

Install the parts in the reverse order of removal. Always connect the positive + terminal first. Make sure that bolts and nuts are tight.

For proper handling of the battery, see "Maintenance Fundamentals." "Battery Goes Dead."

Clip

Removal

1. Press down on the center pin to release the lock.
2. Pull the clip out of the hole.

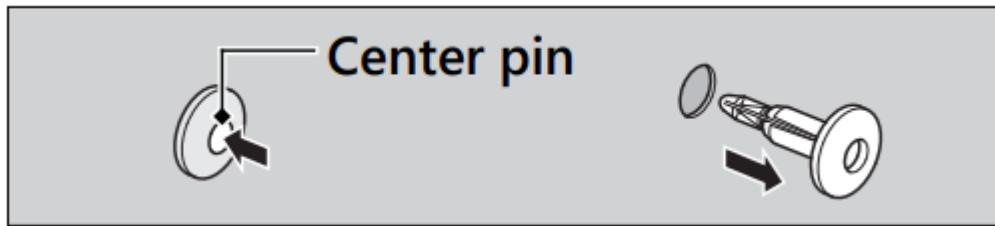

Installation

1. Push the bottom of the center pin.



2. Insert the clip into the hole.
3. Press down on the center pin to lock the clip.

Seat

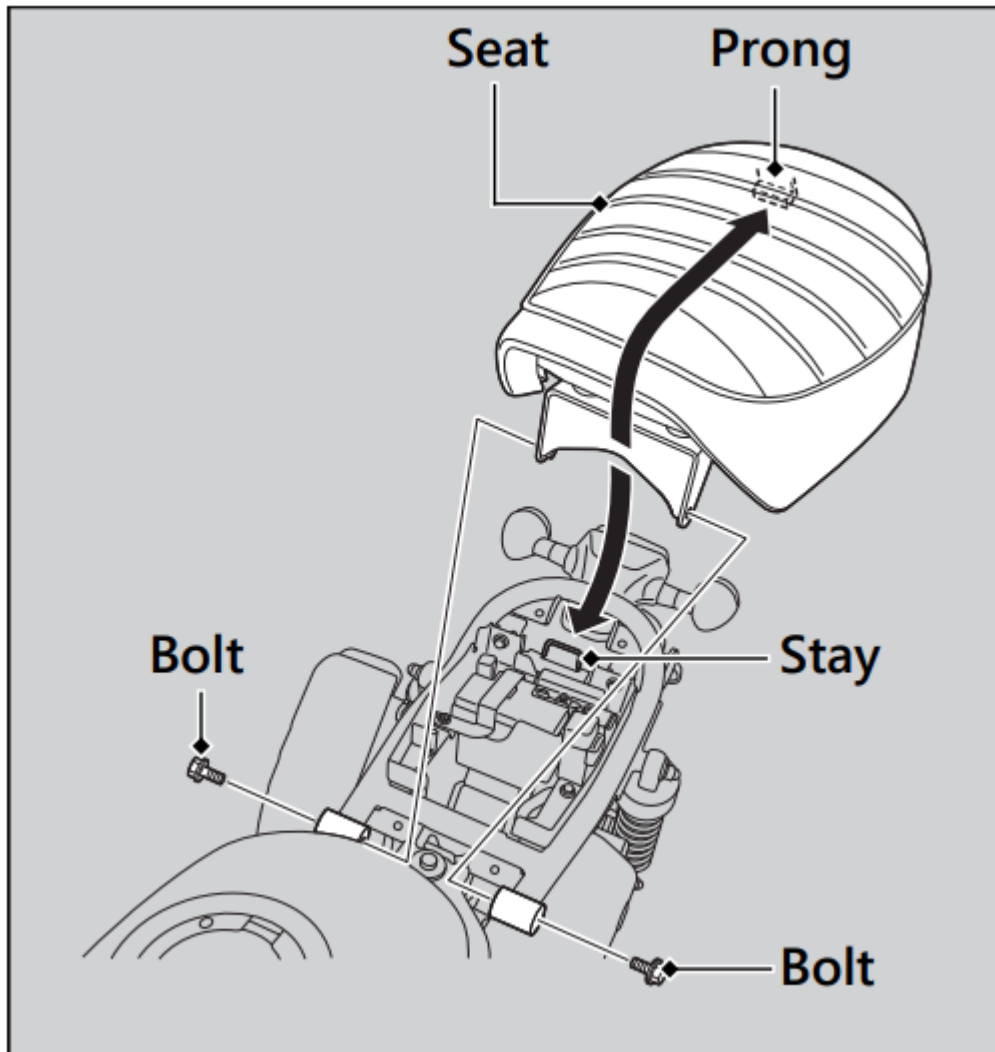

Removal

1. Remove the bolts
2. Pull the seat up and backward.

Installation

1. Insert the prong into the stay on the frame
2. Push forward and down on the rear of the seat until it locks in place.
3. Install and tighten the bolts.

Make sure that the seat is locked securely in position to pull it up lightly.

Left Side Cover

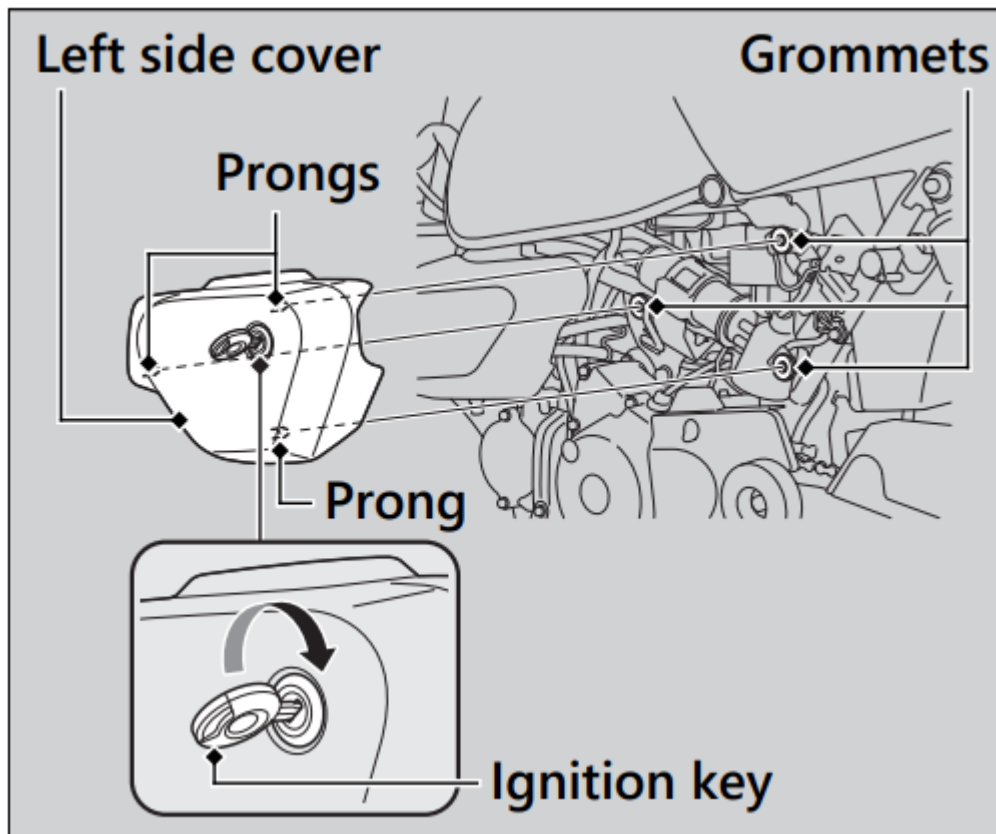

Removal

1. Insert the ignition key into the lock.
2. Carefully pull the left side cover out from the grommets while turning the ignition key clockwise.

Installation

1. Align the prongs with the grommets.
2. Push the left side cover into position while turning the ignition key clockwise.

Make sure that the left side cover is locked securely in position by pulling it lightly.

3. Remove the ignition key

Engine Oil

Checking the Engine Oil

1. If the engine is cold, idle the engine for 3 to 5 minutes.
2. Turn the ignition switch to the OFF position and wait for 2 to 3 minutes.
3. Place your vehicle in an upright position on a firm, level surface.
4. Check that the oil level is between the upper level and lower level marks on the oil level inspection window.

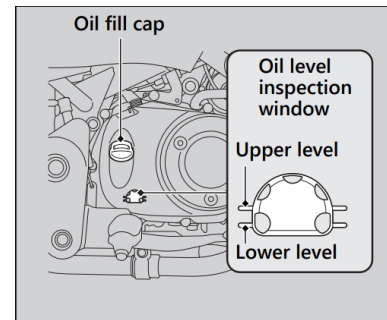

Adding Engine Oil

If the engine oil is below or near the lower level mark, add the recommended engine oil.

1. Remove the oil fill cap. Add the recommended oil until it reaches the upper level mark.

Place your vehicle in an upright position on a firm, level surface when checking the oil level.

Do not overfill above the upper level mark.

Make sure no foreign objects enter the oil filler opening.

Wipe up any spills immediately.

2. Securely reinstall the oil fill cap.

For the recommended oil and oil selection guidelines, see "Maintenance Fundamentals."

Brakes

Checking Brake Fluid

1. Place your vehicle in an upright position on a firm, level surface.
2. **Front Check** that the brake fluid reservoir is horizontal and that the fluid level is above the LOWER level mark.

Rear Check that the brake fluid reservoir is horizontal and that the fluid level is between the LOWER level and UPPER level marks.

If the brake fluid level in either reservoir is below the LOWER level mark or the brake lever and pedal freeplay becomes excessive, inspect the brake pads for wear.

If the brake pads are not worn, you most likely have a leak. Have your vehicle inspected by your dealer.

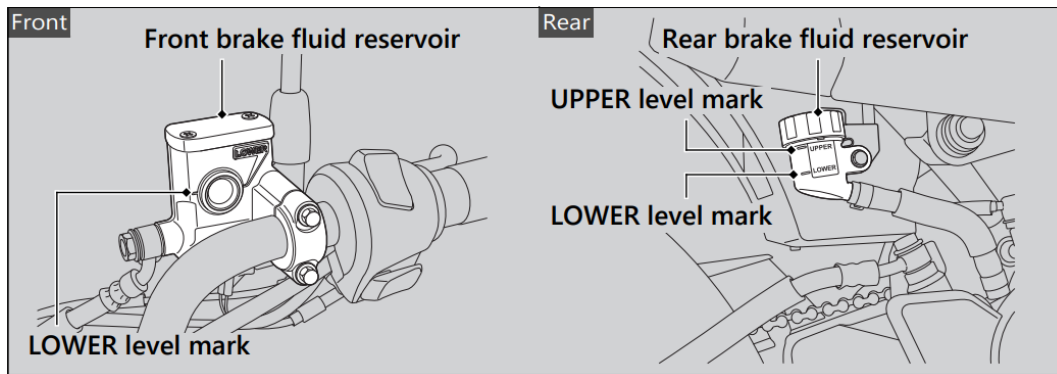

Inspecting the Brake Pads

Check the condition of the brake pad wear indicators.

The pads need to be replaced if a brake pad is worn to the indicator.

1. **Front** Inspect the brake pads from below the brake caliper.
2. **Rear** Inspect the brake pads from the rear right of the vehicle.

If necessary have the pads replaced by your dealer.

Always replace both left and right brake pads at the same time.

Adjusting the Brake Light Switch

Check the operation of the brake light switch. Hold the brake light switch and turn the adjusting nut in the direction A if the switch operates too late, or turn the nut in the direction B if the switch operates too soon.

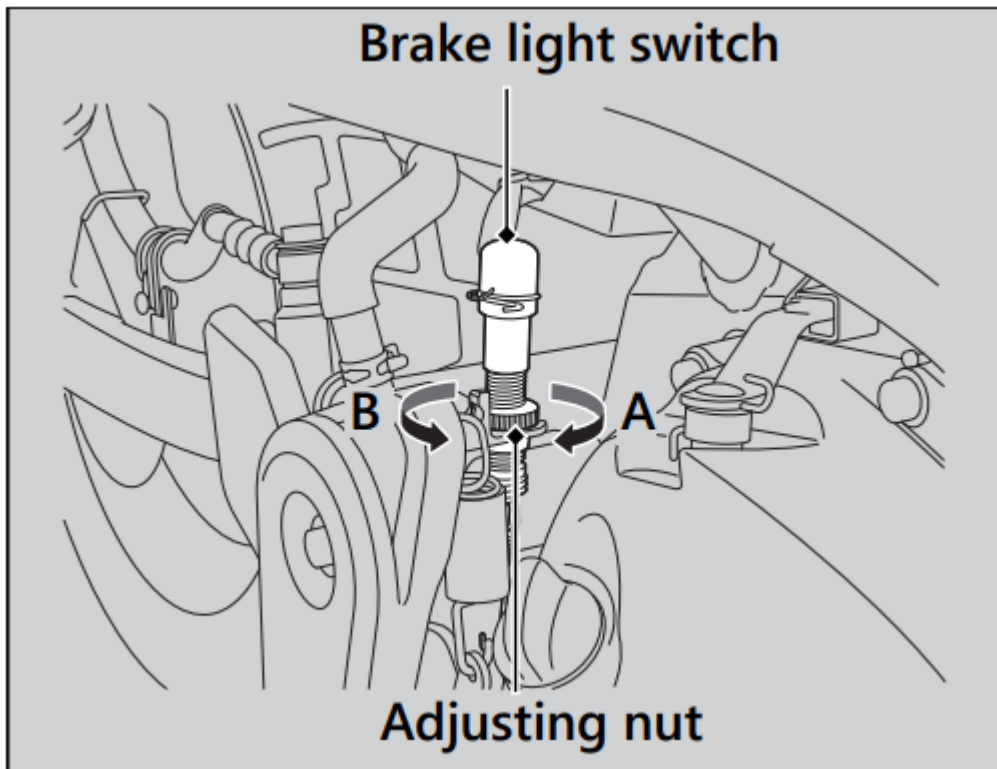

Side Stand

Checking the Side Stand

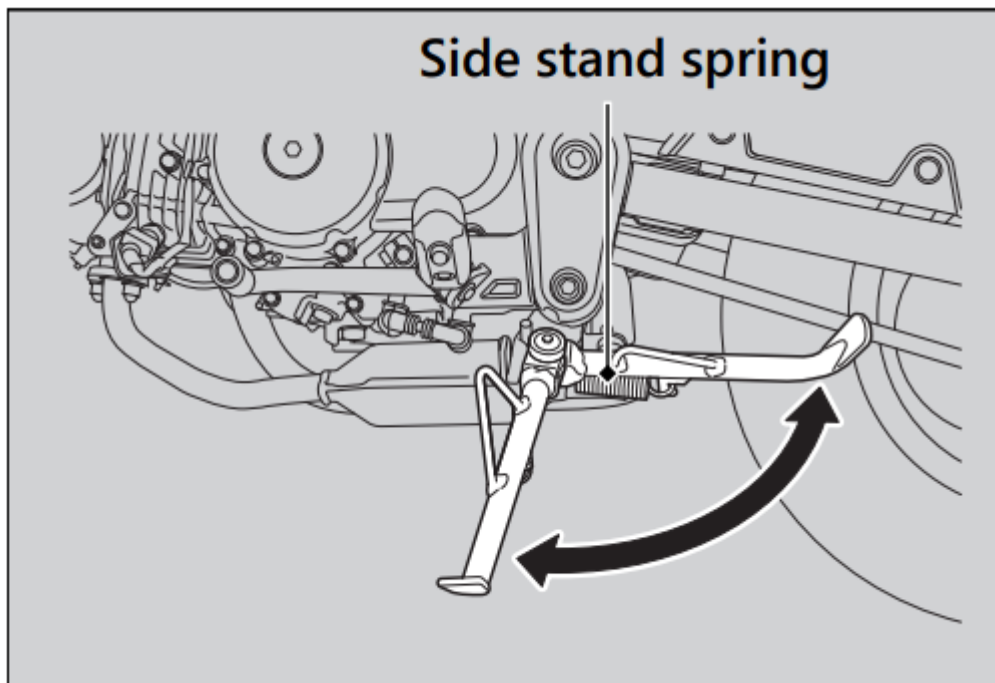

1. Check that the side stand operates smoothly. If the side stand is stiff or squeaky, clean the pivot area and lubricate the pivot bolt with clean grease.
2. Check the spring for damage or loss of tension.
3. Sit on the vehicle, shift the transmission to Neutral, and raise the side stand.

4. Start the engine, pull the clutch lever in, and shift the transmission into gear.
5. Lower the side stand all the way. The engine should stop as you lower the side stand. If the engine doesn't stop, have your vehicle inspected by your dealer.

Drive Chain

Inspecting the Drive Chain Slack

Check the drive chain slack at several points along the chain. If the slack is not constant at all points, some links may be kinked and binding. Have the chain inspected by your dealer.

1. Shift the transmission to Neutral. Stop the engine.
2. Place your vehicle on its side stand on a firm, level surface.
3. Check the slack in the lower half of the drive chain midway between the sprockets.

Drive chain slack:

1 3/16 - 1 9/16 in (30 - 40 mm)

Do not ride your vehicle if the slack exceeds 1 15/16 in (50 mm).

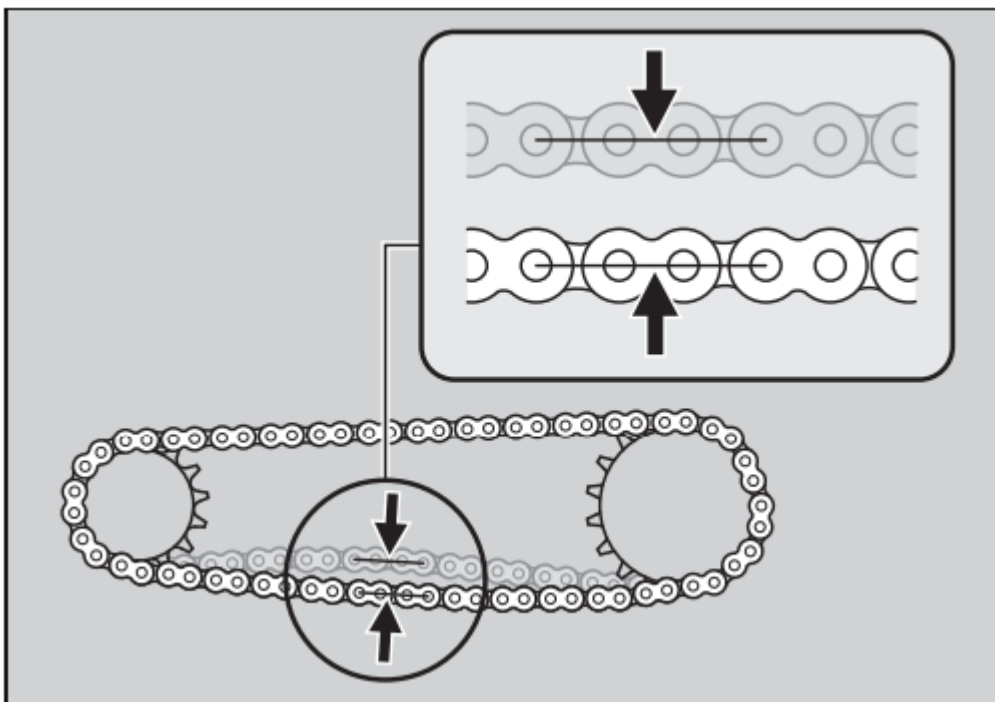

4. Roll the vehicle forward and check that the chain moves smoothly.
5. Inspect the sprockets.
6. Clean and lubricate the drive chain.

Clutch

Checking the Clutch

Checking the Clutch Lever Freeplay

Check the clutch lever freeplay.

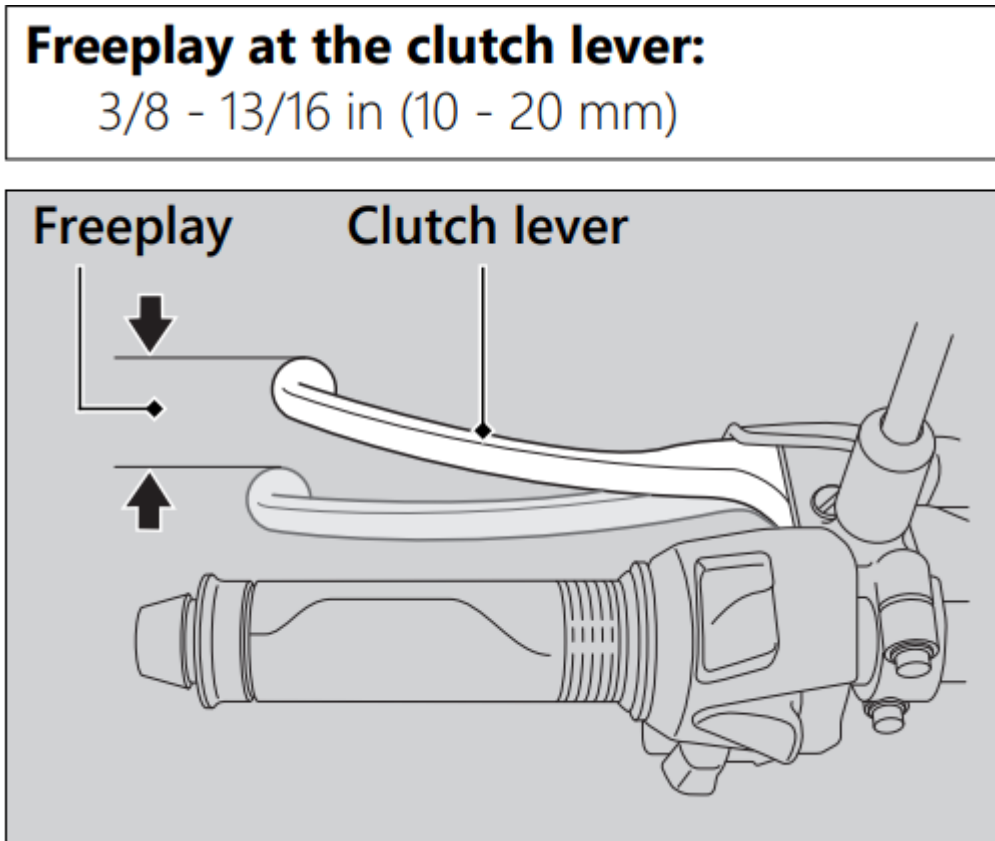

Check the clutch cable for kinks or signs of wear. If necessary have it replaced by your dealer.

Lubricate the clutch cable with a commercially available cable lubricant to prevent premature wear and corrosion.

Adjusting the Clutch Lever Freeplay

Upper Adjustment

Attempt adjustment with the upper clutch cable adjuster first.

1. Pull back the rubber dust cover.
2. Loosen the upper lock nut.
3. Turn the upper clutch cable adjuster until the freeplay is 3/8 - 13/16 in (10 - 20 mm)
4. Tighten the upper lock nut and check the freeplay again.
5. Reinstall the rubber dust cover.

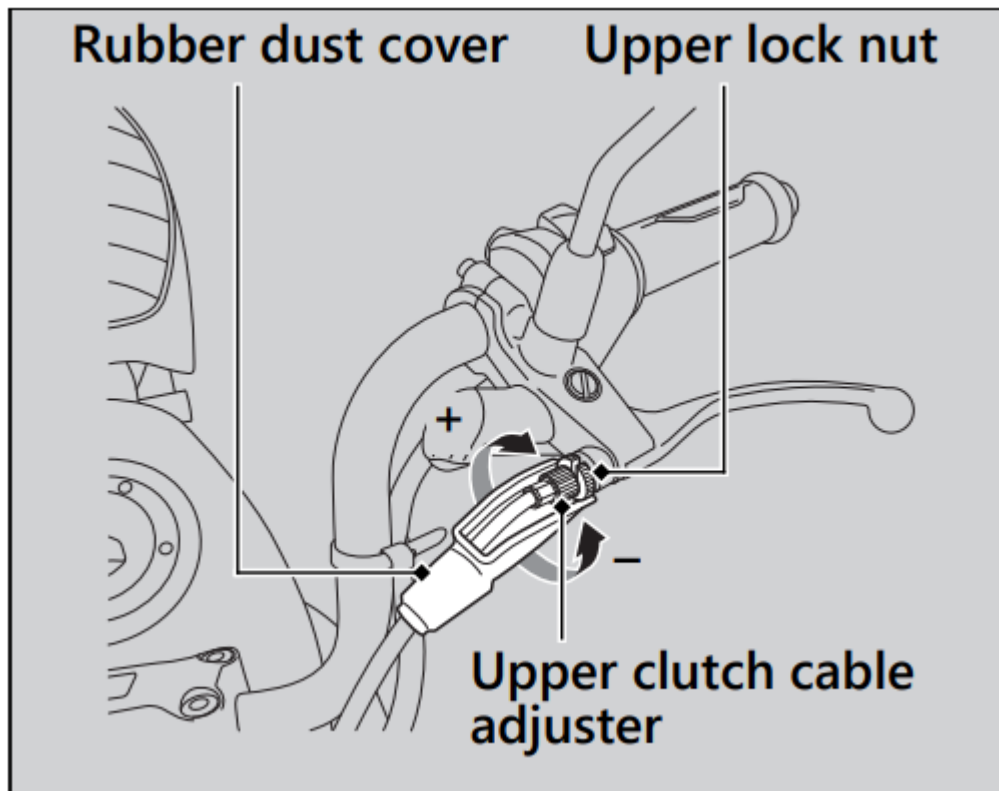

Lower Adjustment

If the upper clutch cable adjuster is threaded out near its limit, or the correct freeplay cannot be obtained, attempt adjustment with the lower clutch cable adjusting nut.

1. Loosen the upper lock nut and turn the upper clutch cable adjuster all the way in (to provide maximum freeplay). Tighten the upper lock nut.
2. Loosen the lower lock nut.
3. Turn the lower clutch cable adjusting nut until the clutch lever freeplay is $\frac{3}{8}$ - $\frac{13}{16}$ in (10 - 20 mm).
4. Tighten the lower lock nut and check the clutch lever freeplay.
5. Start the engine, pull the clutch lever in, and shift into gear. Make sure the engine does not stall and the vehicle does not creep. Gradually release the clutch lever and open the throttle. Your vehicle should move smoothly and accelerate gradually.

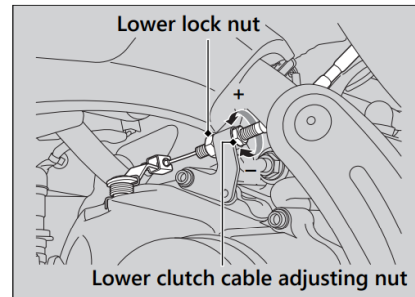

If proper adjustment cannot be obtained or the clutch does not work correctly, see your dealer.

Throttle

Checking the Throttle

With the engine off, check that the throttle rotates smoothly from fully closed to fully open in all steering positions and throttle freeplay is correct. If the throttle does not move smoothly, close automatically, or if the cable is damaged, have the vehicle inspected by your dealer.

Freeplay at the throttle grip flange:

1/16 - 1/4 in (2 - 6 mm)

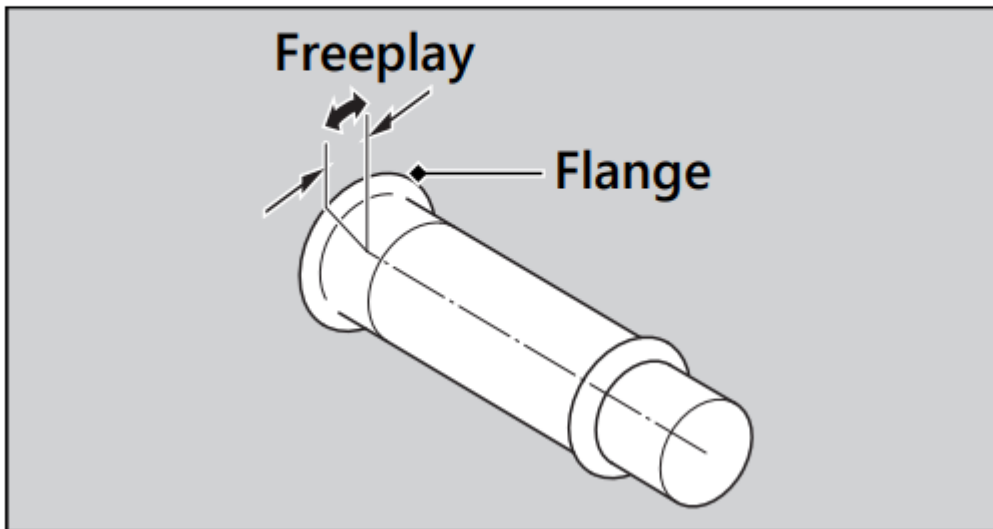

Troubleshooting

Engine Will Not Start

Starter Motor Operates But Engine Does Not Start

Check the following items:

- Check the correct engine starting sequence.
- Check that there is gasoline in the fuel tank.
- Check if the PGM-FI malfunction indicator lamp (MIL) is on.

If the indicator lamp is on, contact your dealer as soon as possible.

Starter Motor Does Not Operate

Check the following items:

- Check the correct engine starting sequence.
- Make sure engine stop switch is in the  (Run) position.
- Check for a blown fuse.
- Check for a loose battery connection or battery terminal corrosion
- Check the condition of the battery.

If the problem continues, have your vehicle inspected by your dealer.

Warning Indicators On or Flashing

PGM-FI (Programmed Fuel Injection) Malfunction Indicator Lamp (MIL)

If the indicator comes on while riding, you may have a serious problem with the PGM-FI system. Reduce speed and have your vehicle inspected by your dealer as soon as possible.

ABS (Anti-lock Brake System) Indicator

Monkey125A only

If the indicator operates in one of the following ways, you may have a serious problem with the ABS. Reduce your speed and have your vehicle inspected by your dealer as soon as possible.

- Indicator comes on or starts flashing while riding.
- Indicator does not come on when the ignition switch is in the ON position.
- Indicator does not go off at speeds above 6 mph (10 km/h).

If the ABS indicator stays on, your brakes will continue to work as a conventional system, but without the anti-locking function.

The ABS indicator may flash if you turn the rear wheel while the rear wheel is lifted off the ground. In this case, turn the ignition switch to the OFF position, and then to the ON position again. The ABS indicator will go off after your speed reaches 19 mph (30 km/h).

Other Warning Indications

Fuel Gauge Failure Indication

If the fuel system has an error, the fuel gauge indicators will be displayed as shown in the illustration.

If this occurs, see your dealer as soon as possible.

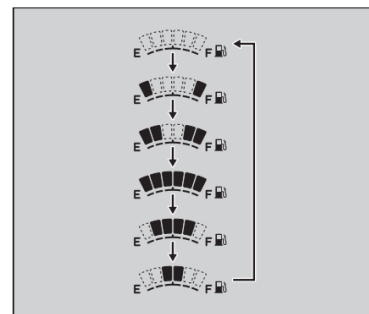
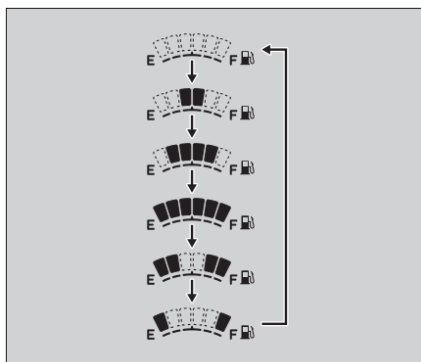

Tire Puncture

Repairing a puncture or removing a wheel requires special tools and technical expertise. We recommend you have this type of service performed by your dealer.

After an emergency repair, always have the tire inspected/replaced by your dealer.

Emergency Repair Using a Tire Repair Kit

If your tire has a minor puncture, you can make an emergency repair using a tubeless tire repair kit.

Follow the instructions provided with the emergency tire repair kit.

Riding your vehicle with a temporary tire repair is very risky. Do not exceed 30 mph (50 km/h). Have the tire replaced by your dealer as soon as possible.

Electrical Trouble

Battery Goes Dead

Charge the battery using a motorcycle battery charger.

Remove the battery from the vehicle before charging.

Do not use an automobile-type battery charger, as these can overheat a motorcycle battery and cause permanent damage. If the battery does not recover after recharging, contact your dealer.

Burned-out Light Bulb

Follow the procedure below to replace a burned-out light bulb.

Turn the ignition switch to the OFF or LOCK position.

Allow the bulb to cool before replacing it.

Do not use bulbs other than those specified.

Check the replacement bulb for correct operation before riding.

For the light bulb wattage, see "Specifications."

The headlight/position light/brake light/ taillight/license plate light uses several LEDs. If there is an LED which is not turned on, see your dealer for servicing.

Front/Rear Turn Signal Bulb

1. Remove the screw.
2. Remove the turn signal lens.
3. Slightly press the bulb in and turn it counterclockwise.

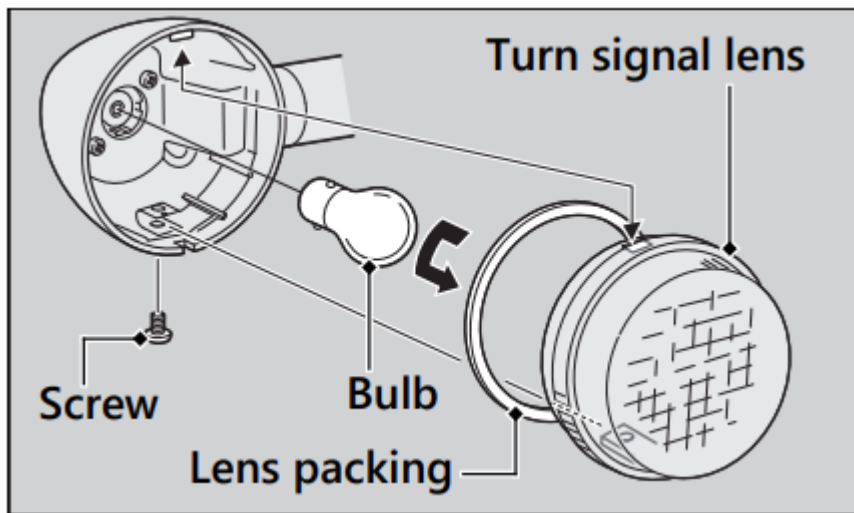

4. Install a new bulb and the parts in the reverse order of removal.

After putting back the lens packing in place, install the turn signal lens.

Blown Fuse

Before handling fuses, see “Inspecting and Replacing Fuses.”

Fuse Box Fuses

1. Remove the seat.
2. Remove the fuse box cover.
3. Pull the fuses out one by one with the fuse puller in the tool kit and check for a blown fuse. Always replace a blown fuse with a spare fuse of the same rating.

Spare fuses are provided near the battery.

4. Reinstall the fuse box cover.
5. Reinstall the seat.

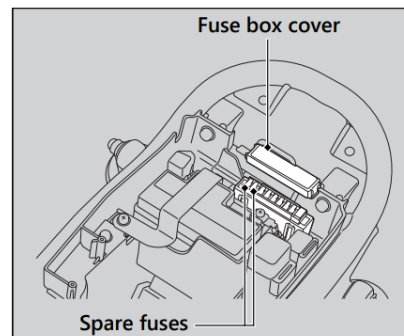

Unstable Engine Operation Occurs Intermittently

If the fuel pump filter is clogged, unstable engine operation will occur intermittently while riding.

Even if this symptom occurs, you can continue to ride your vehicle.

If unstable engine operation occurs even if sufficient fuel is available, have your vehicle inspected by your dealer as soon as possible.

Warning

This content is compiled from multiple sources and is provided for reference purposes only. It may not be complete or fully applicable to all situations. If you are unable to resolve your issue, please contact the product manufacturer or an authorized service provider for official support.

Document generated by [ManualsFile](#)