

Parts and Features

It is important to know your vacuum cleaner's parts and features to ensure its proper and safe use. Review these before using your vacuum cleaner.

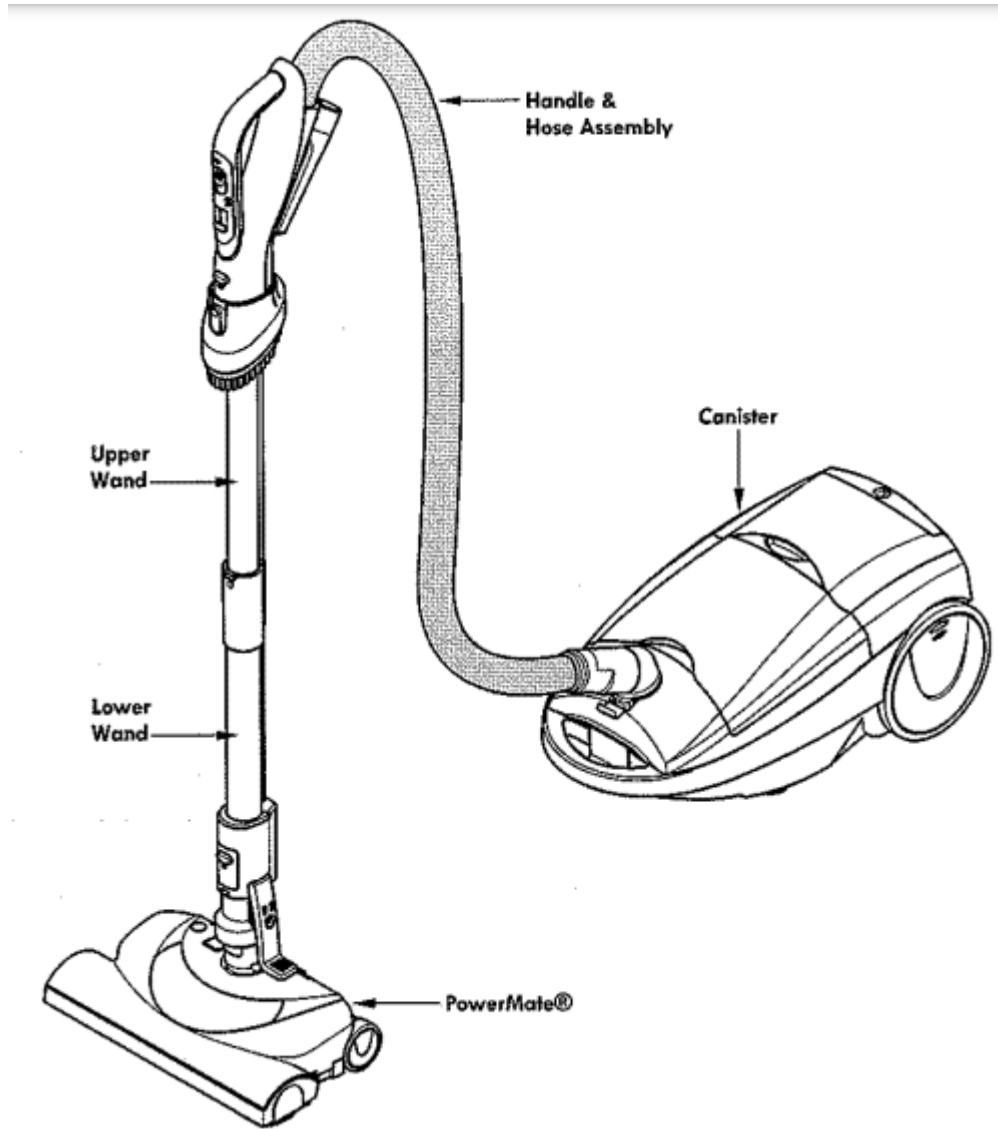

Replacment Parts



Object	Style No.	Part No. in USA	Part No. in Canada
Belt	CB-3	20-5218	20-40118
Headlight Bulb	-----	20-5248	20-40601
Dust Bag - Standard	C	20-50558	20-50403
Dust Bag - HEPA Media	Q	20-53291	20-50410
Exhaust Filter	EF-1	20-86889	20-40324
Motor Safety Filter	CF-1	20-86883	20-40321

PowerMate & Wands

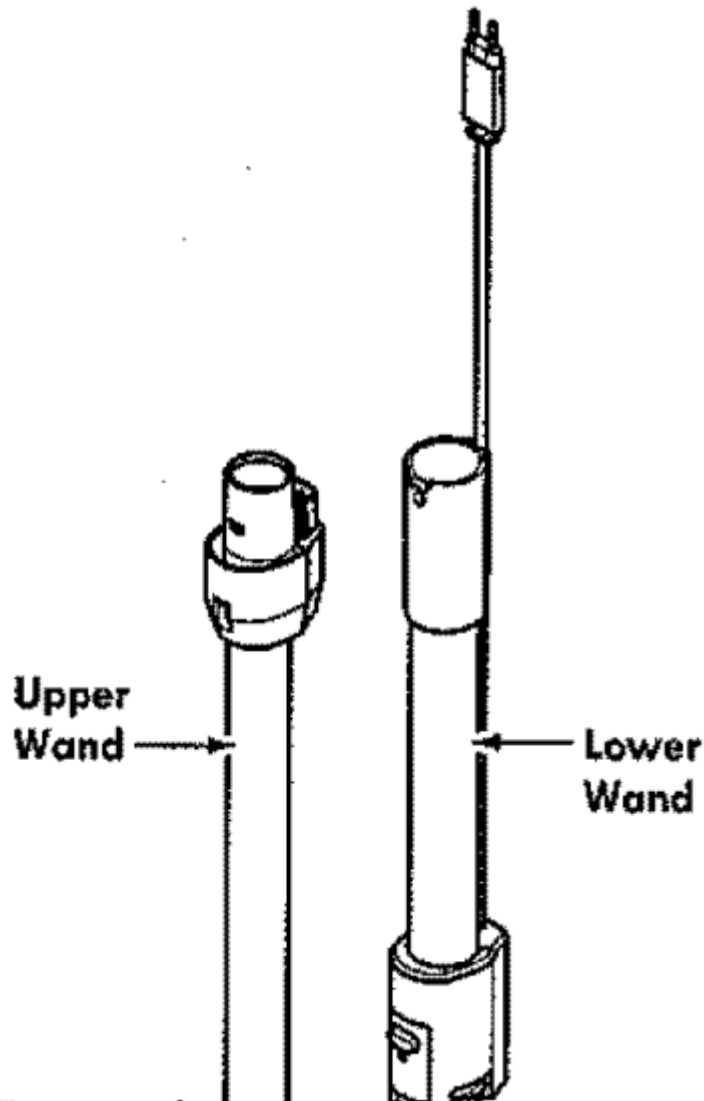

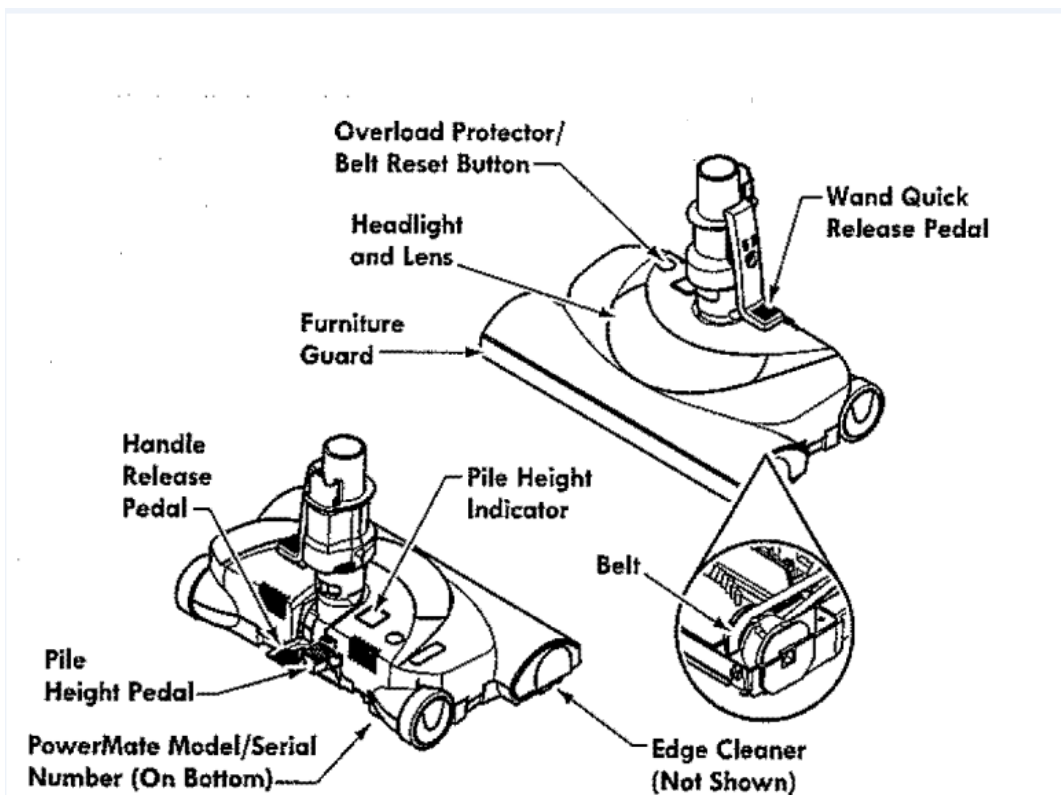

HANDLE & HOSE ASSEMBLY

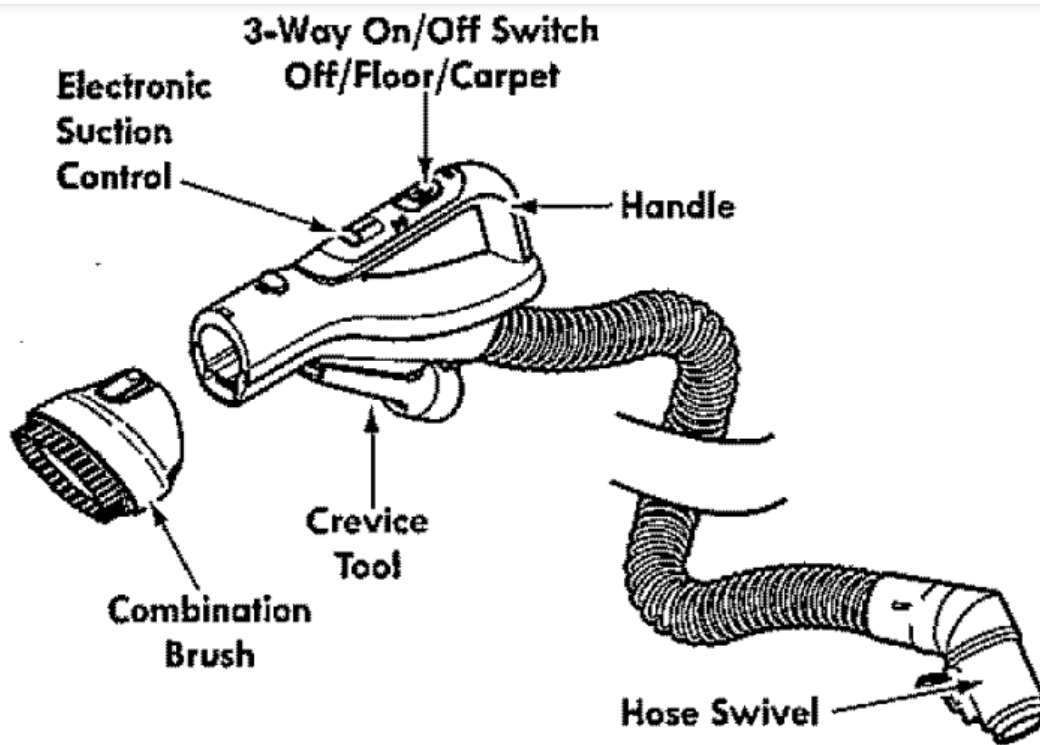

CANISTER



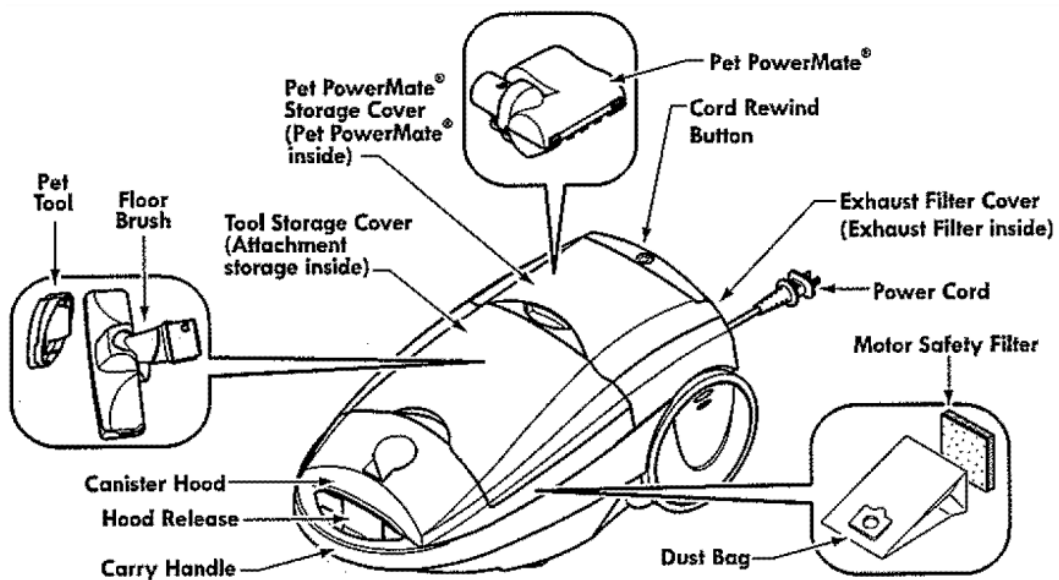

Assembly Instructions

Powermate

Insert wand onto PowerMate until the wand locks into place

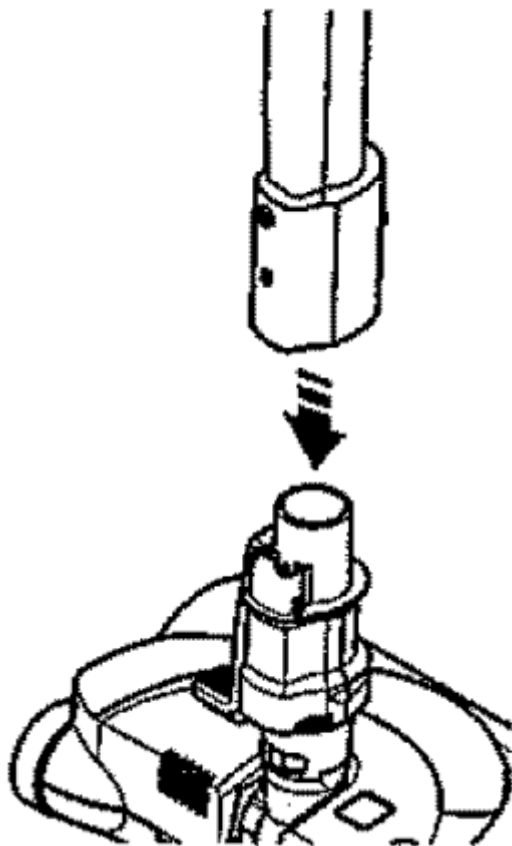

Canister

1. Open the canister hood.
2. Check to see that the dust bag is properly installed. See BAG CHANGING (page 20) for instructions.
3. Check to see that the motor safety filter is properly installed. See MOTOR SAFETY FILTER CLEANING (page 21) for instructions.

Hood and tool storage cover

It is normal for the canister hood and tool storage cover to come off when opened further than needed. Line up the hinge slots, insert the hinges into the slots, and close the hood and tool storage cover to reinstall.

Hose

Line up the hose latch tab and notch in canister hood and insert hose into canister until it snaps into place.

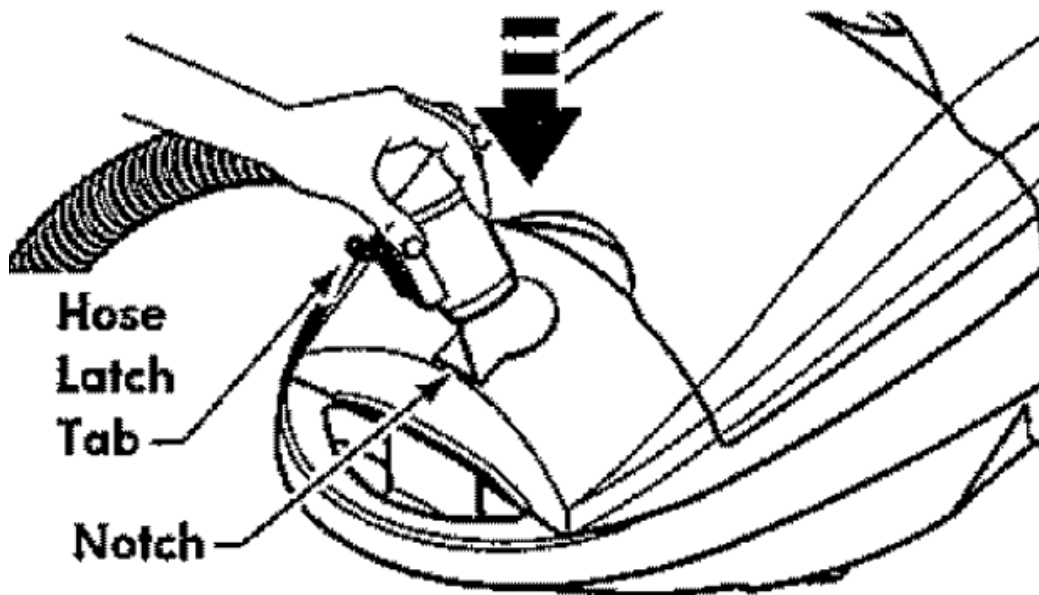

To remove: Do not open hood before removing hose. With hood closed, depress hose latch tab. Pull upward on hose.

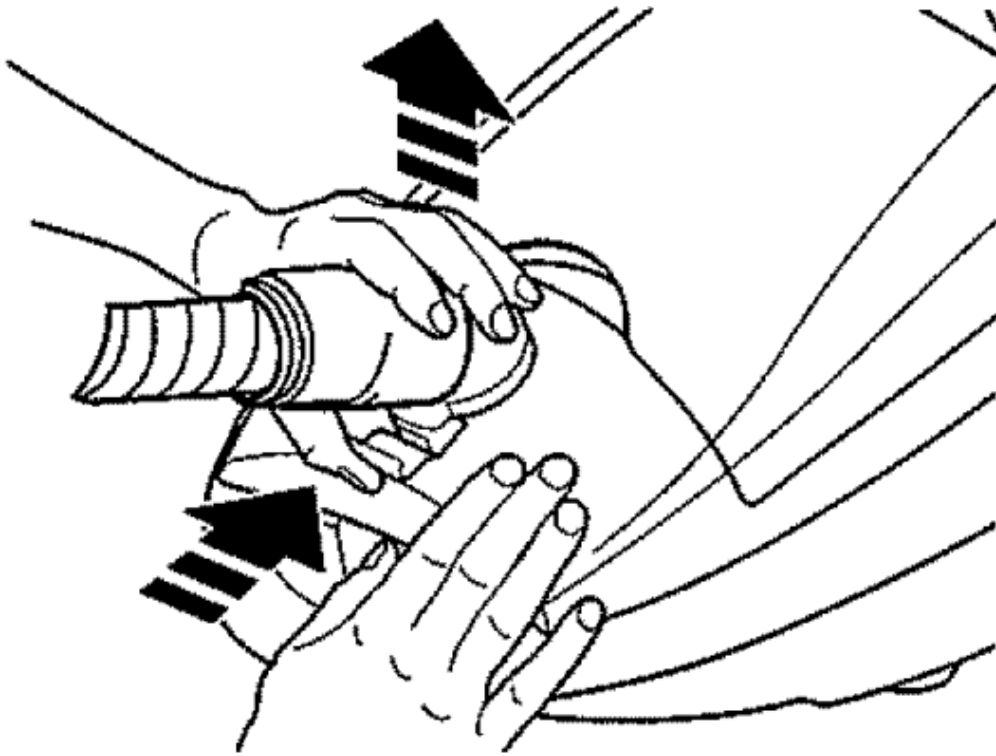

Wands

1. Insert upper wand into lower wand until lock button snaps in place.

To remove: Press wand lock button and pull wands apart.

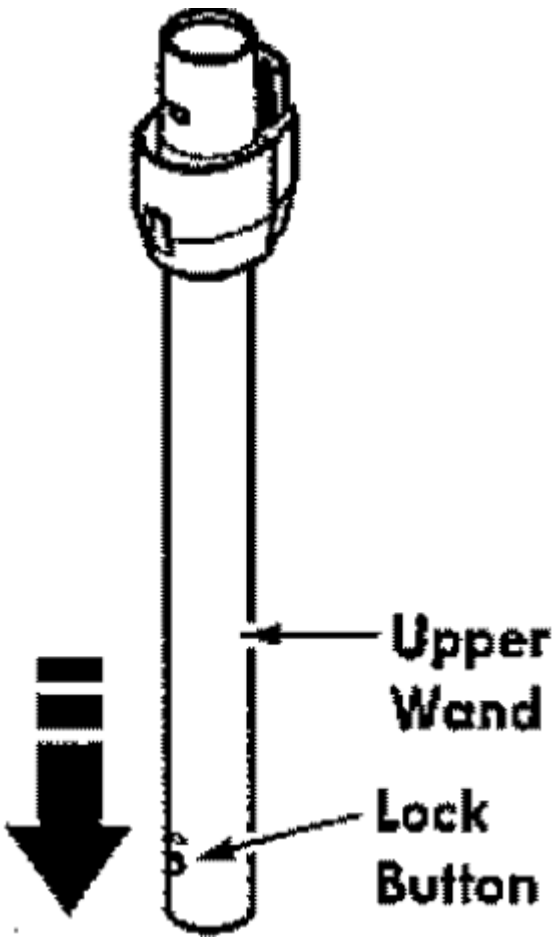

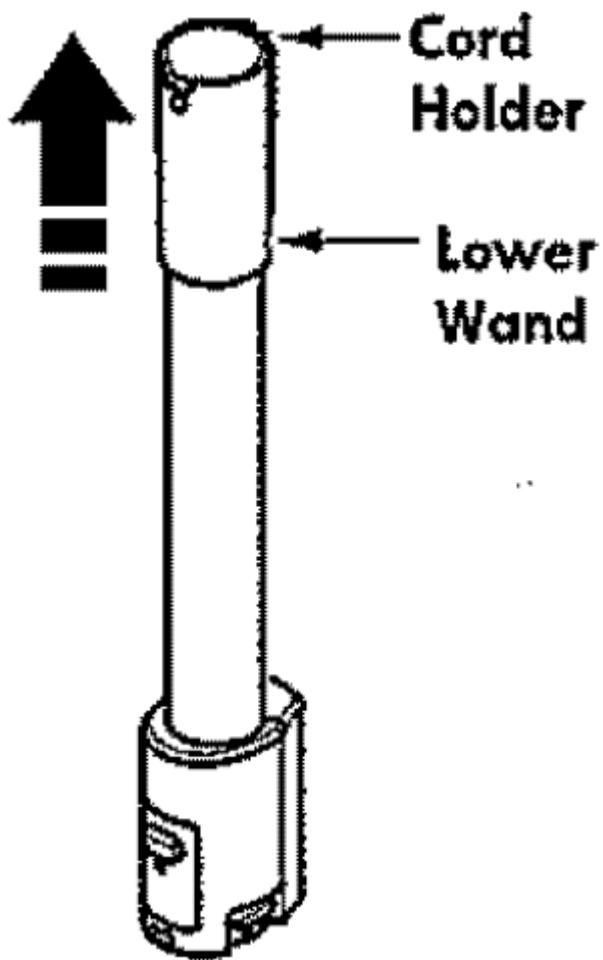

2. insert the plug of the Power Mate® cord into the plug holder as shown. Do not force.

Raised area of the plug must be forwards hand.

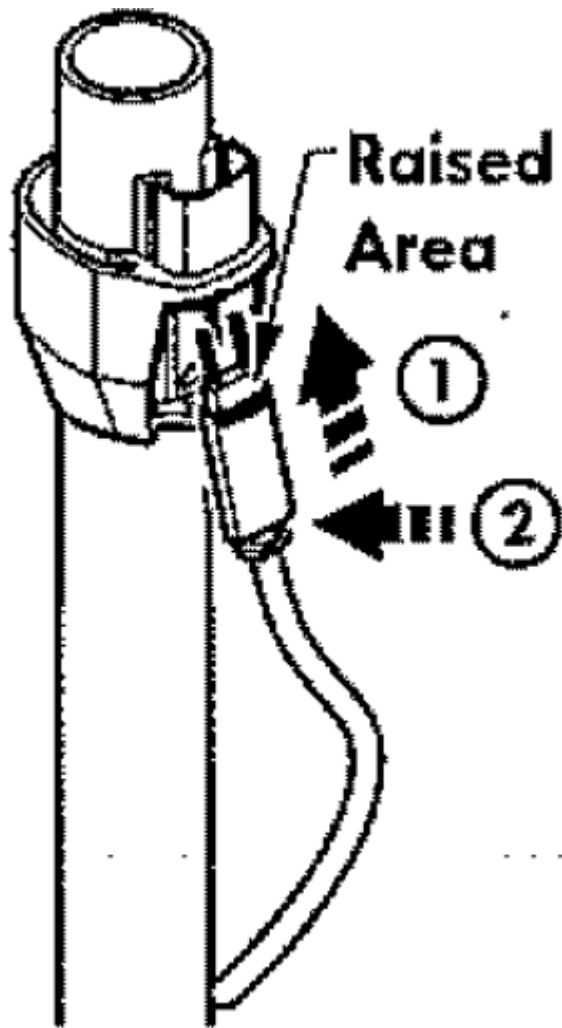

3. Secure the cord into the cord holder on the back of the wand.

Handle

Insert wand into handle until lock button snaps in place. Be sure hose is not twisted.

To remove: Press handle quick release button and pull up on handle.

The combination brush can be stored on the hose handle by placing on hose handle before attaching wand.

To store: Disconnect hose from wand and canister to prevent stress on hose during storage. Store hose in a loosely coiled position so the hose covering is not stressed.

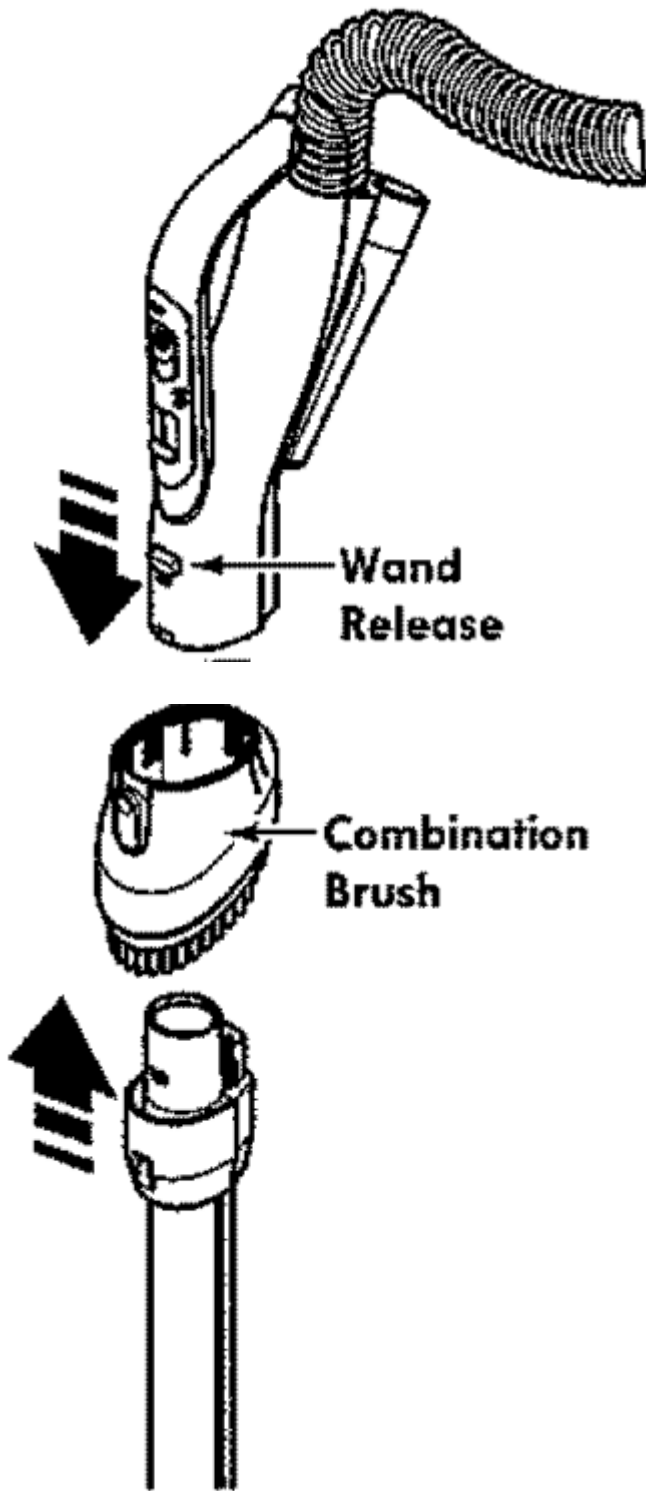

Operating Instructions

How to Start

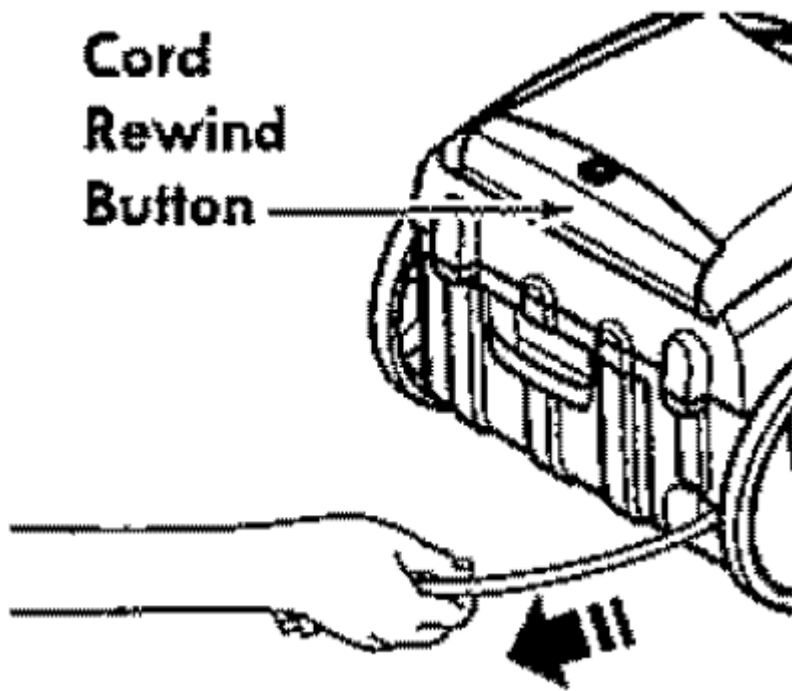

1. Pull cord out of canister to desired length. the cord will not rewind until the cord rewind button is pushed.

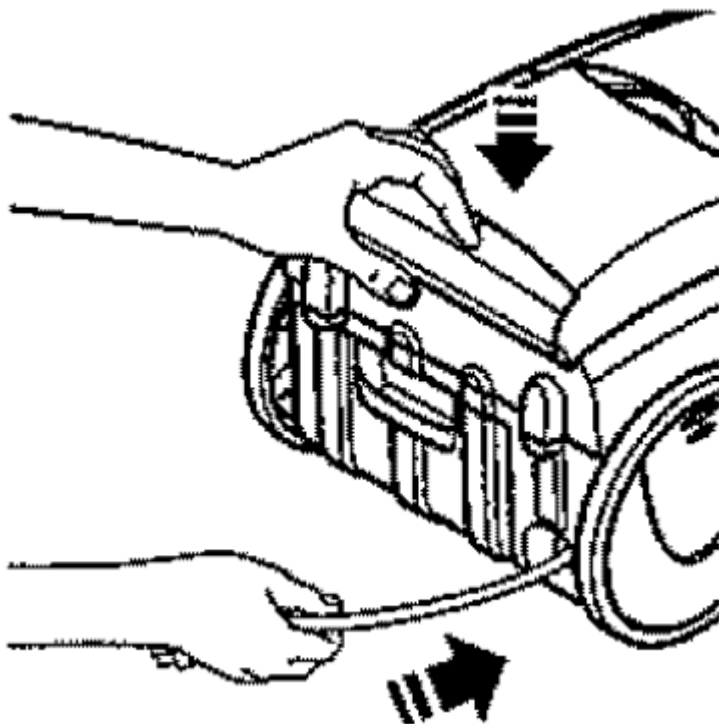

2. Plug the polarized power cord into a 120 Volt outlet located near the floor.

To rewind: Turn off and unplug the vacuum cleaner. Hold the plug while rewinding to prevent damage or injury from the moving cord. Push cord rewind button.

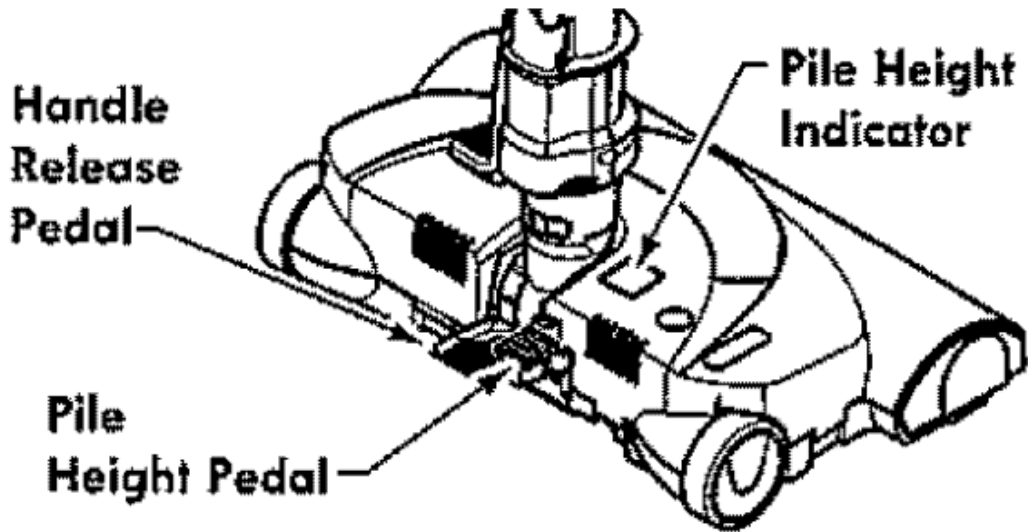

3. Lower wand from upright position by pressing on the handle release pedal.

4. Select a pile height setting by pressing the HEIGHT ADJUST pedal on the rear of the PowerMate. The pffe height setting shows on the indicator. See SUGGESTED PILE HEIGHT SETTINGS (page 13).

Attention: Refer to your carpet manufacturers cleaning recommendations. Some more delicate carpets may require that they be vacuumed with the PowerMate agitator turned off to prevent carpet damage.

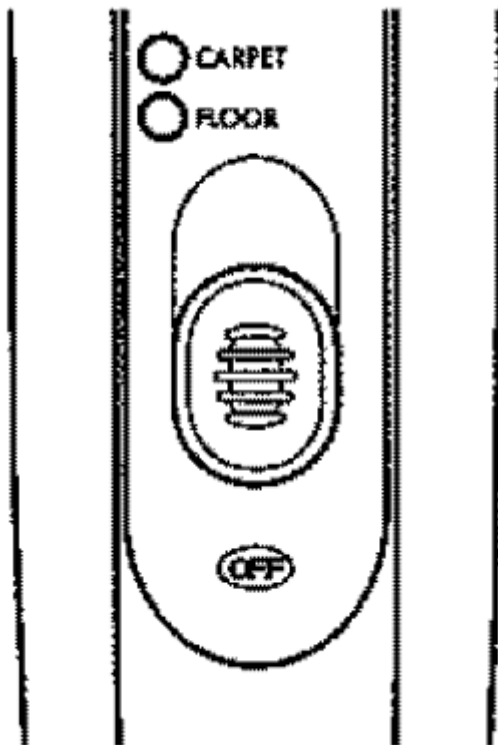

5. Select a position on the handle threeway On/Off switch.

CARPET - turns on both the canister and the PowerMate motors. Headlight and agitator will come on.

FLOOR - turns on the canister motor only.

OFF - Turns vacuum cleaner off.

ELECTRONIC SUCTION CONTROL

The electronic suction control allows you to change the power of the vacuum cleaner suction motor.

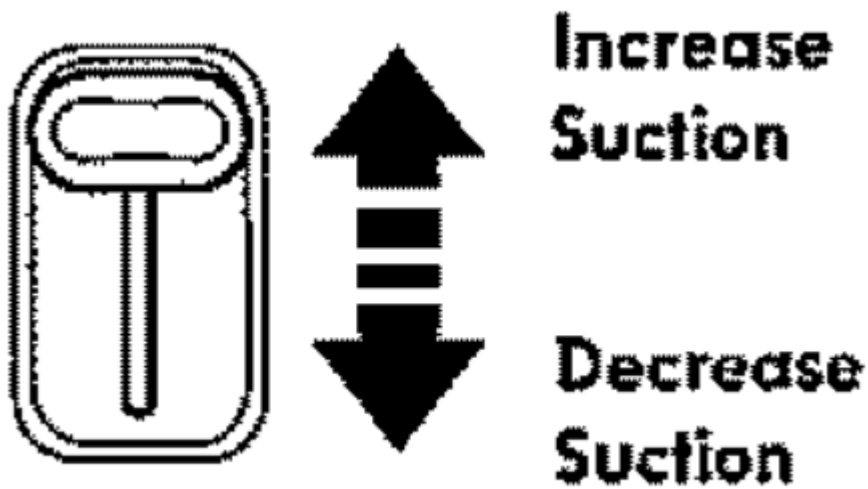

HIGH increases suction for upholsteries and carpets

LOW POWER decreases suction for draperies and lightweight rugs.

Vacuumping Tips

SUGGESTED SWEEPING PATTERN

For best cleaning action, the PowerMate should be pushed straight away from you and pulled straight back. At the end of each pull stroke, the direction of the PowerMate should be changed to point into the next section to be cleaned. This pattern should be continued across the carpet or floor with slow, gliding motions.

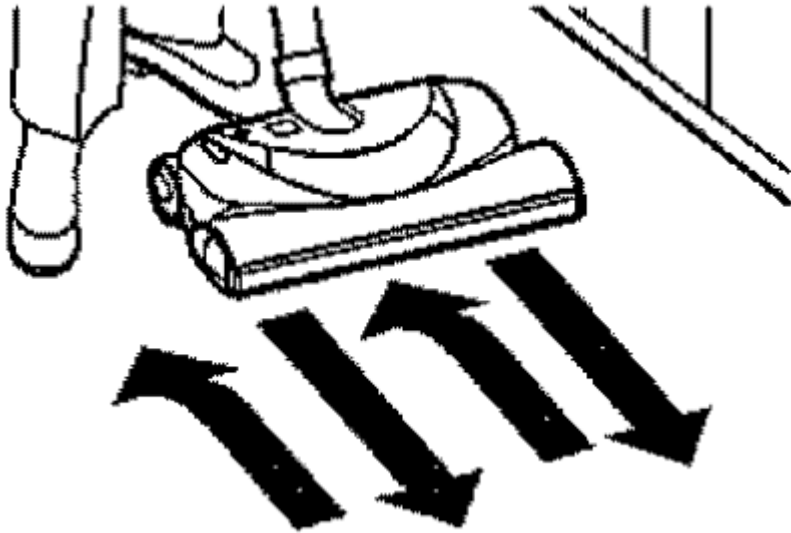

STAIRS GRIP

The stair grip located on the caster will aid in preventing the canister from slipping when used on stairs. During normal operation, while the canister is in the horizontal position, the caster wheel rotates freely 360 .

In order to prevent the canister from slipping on stairs, the STAIR GRIP feature automatically locks the caster wheel in position when the canister is placed on residential stairs,

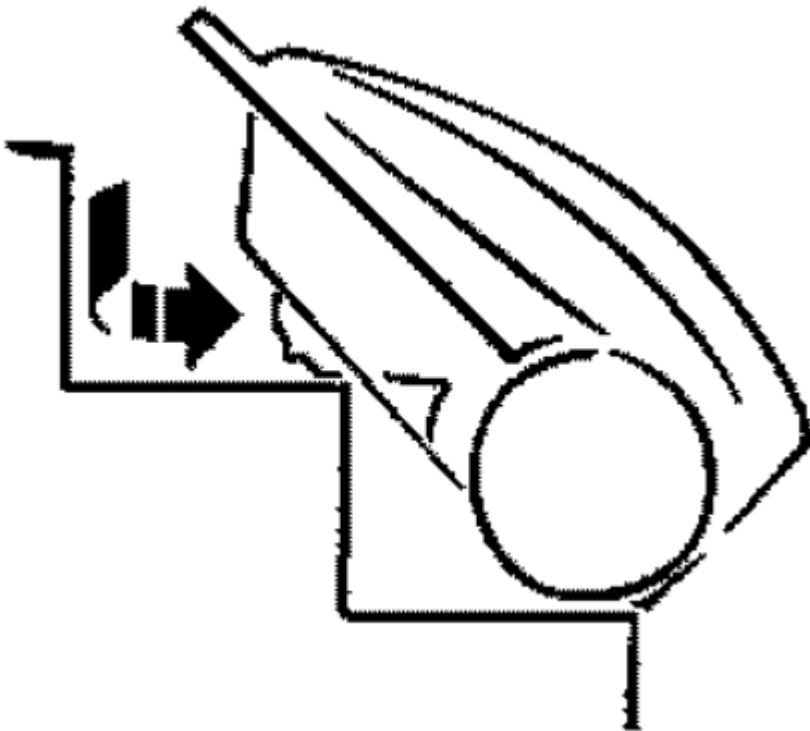

EDGE CLEANER

Active brush edge cleaners are on both sides of the PowerMate. Guide either side of the PowerMate along the wall or next to furniture to help remove dirt trapped at carpet edges.

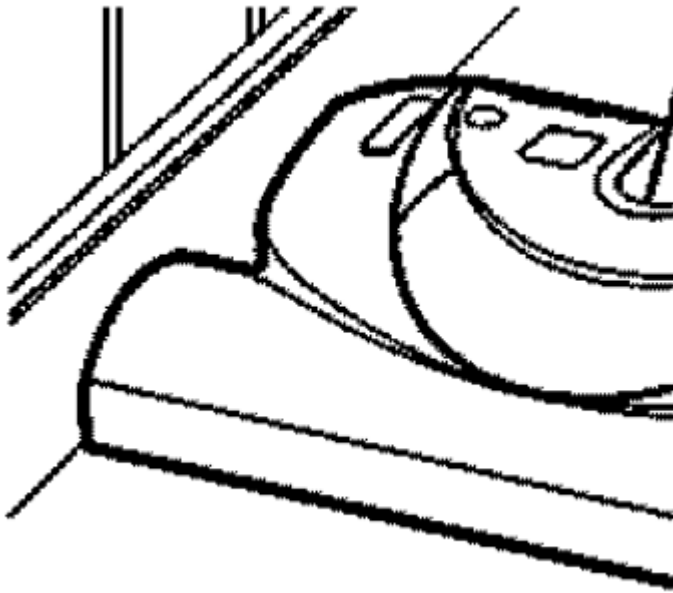

HOSE SWIVEL

The 360 ° hose swivel allows the hose to turn without moving the canister. This is helpful for cleaning in small areas. Check hose for twisting before pulling canister.

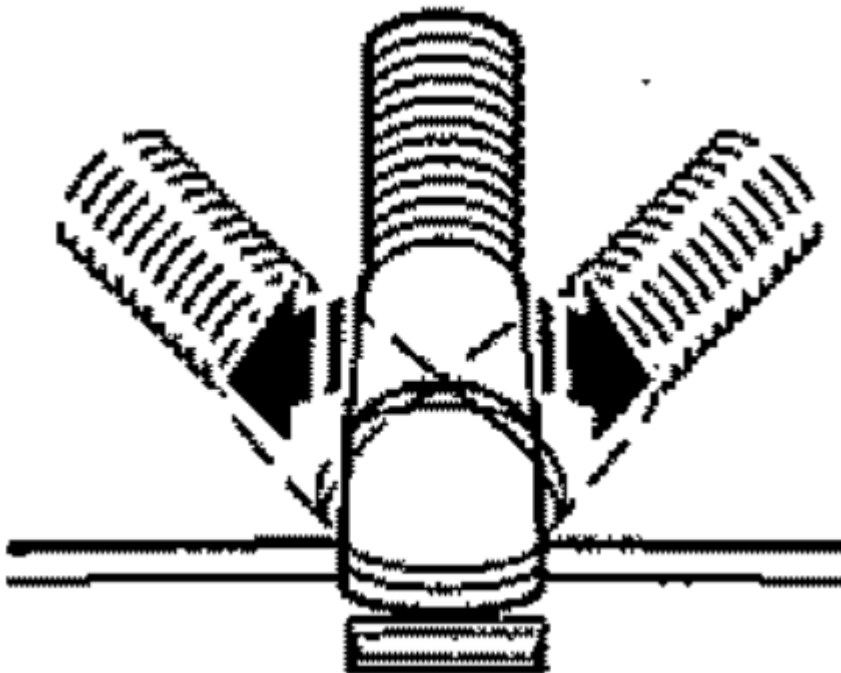

Suggested Pile Height Settings

For best deep-down cleaning, use the XLO setting. However, you may need to raise the height to make some jobs easier, such as scatter rugs and some deep pile carpets, and to prevent the vacuum cleaner from shutting off. Suggested settings are:

HI - Shag, deep pile, or scatter rugs.

MED - Medium to deep pile.

LO - Low to medium pile.

XLO - Most carpets and bare floors.

Attachments

ATTACHMENTS ON HANDLE

NOTE: if the PowerMate is attached turn vacuum cleaner off before removing handle from wand.

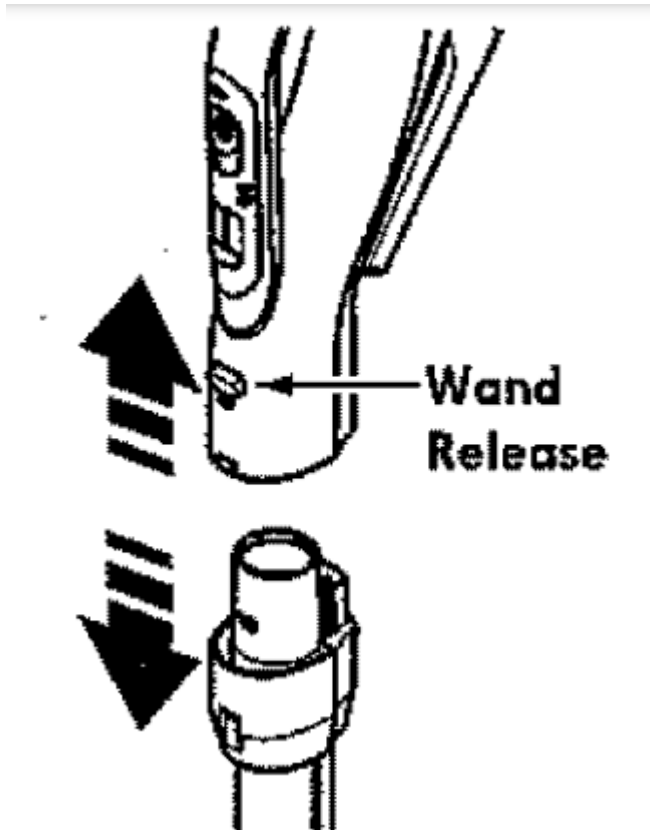

1. Press wand release button and pull on handle
2. Slide attachments firmly on handle as needed. See ATTACHMENT USE TABLE (page 16)

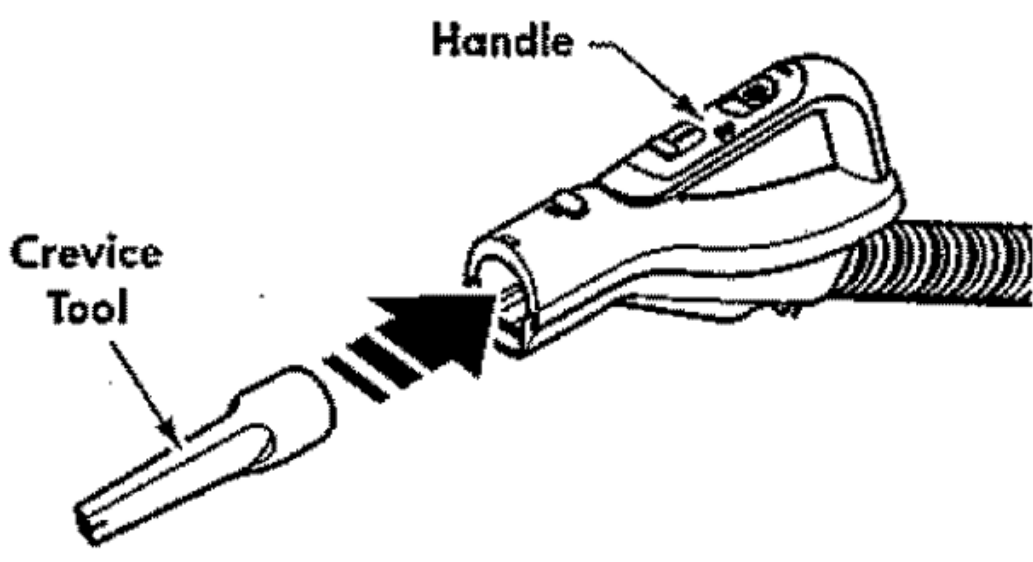
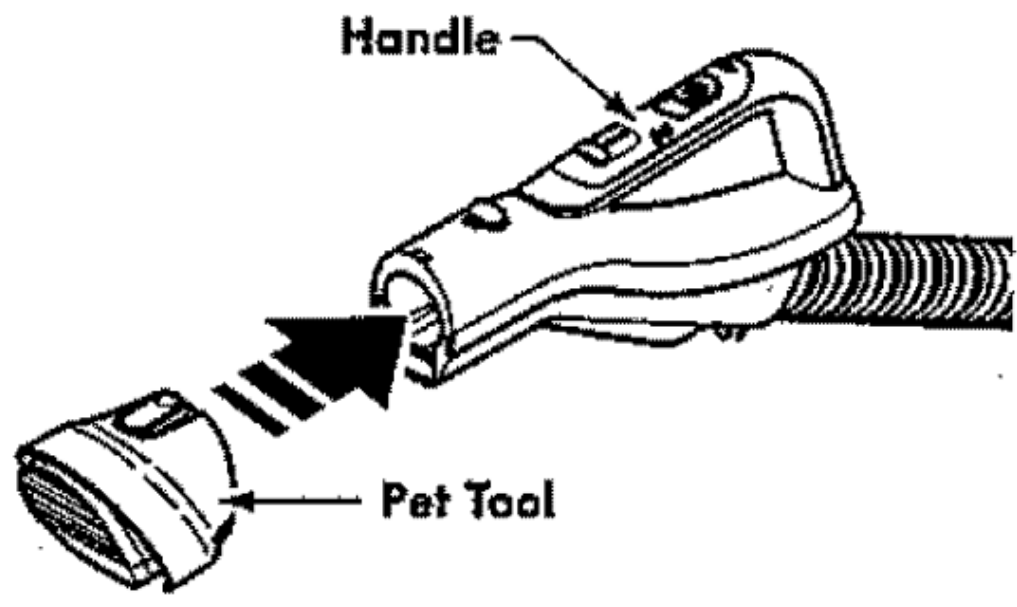
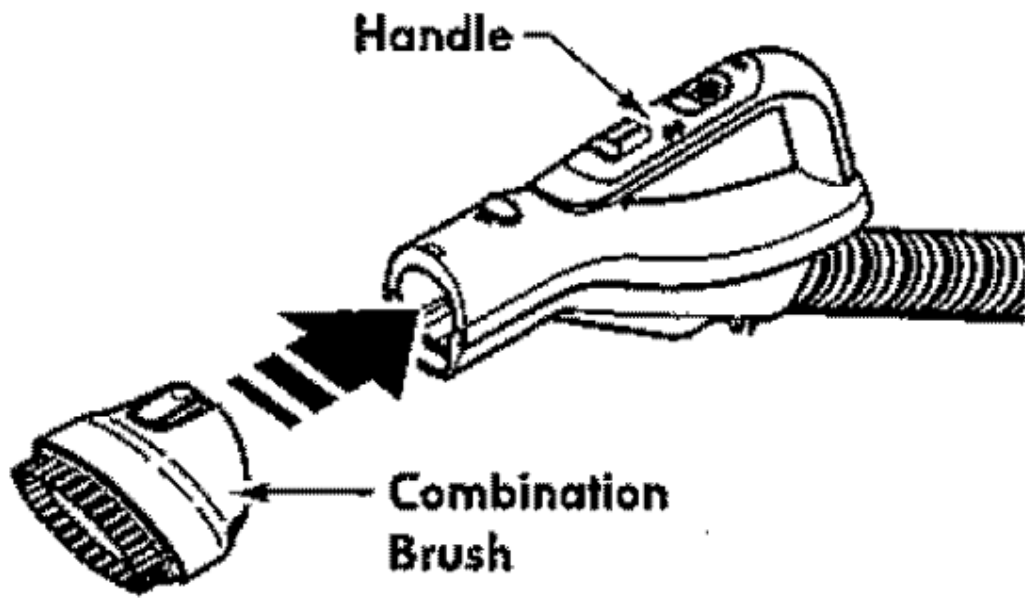

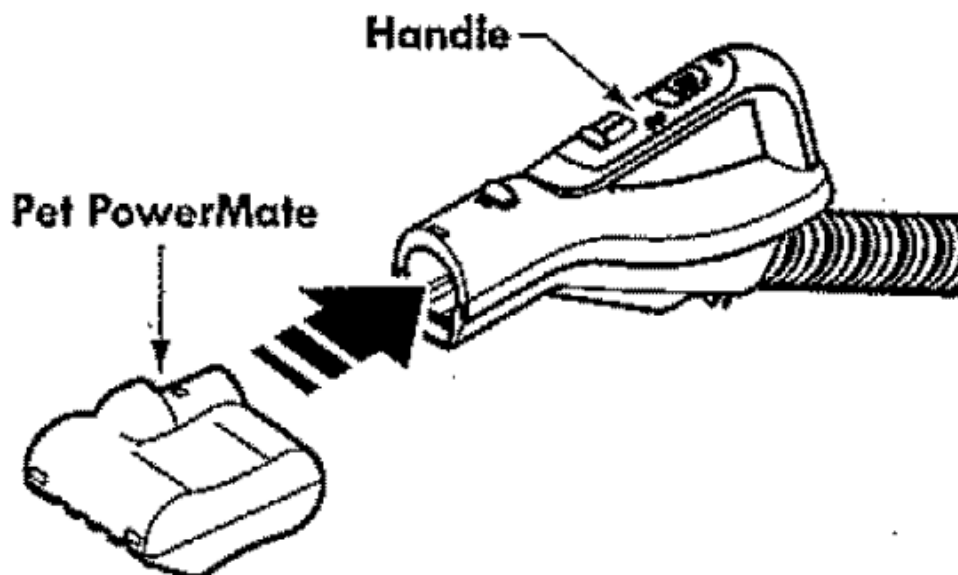
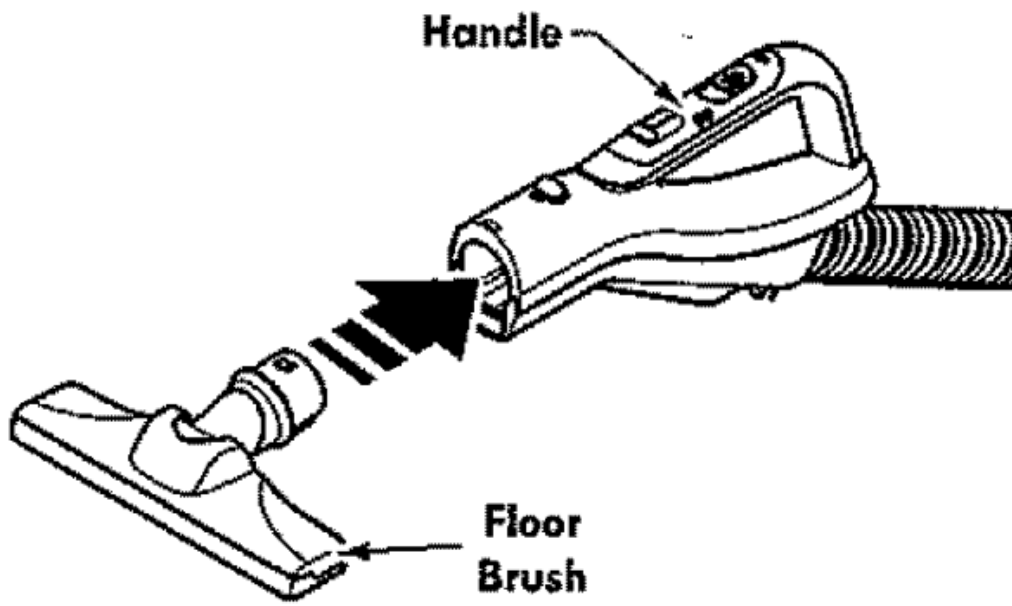

NOTE: To remove combination brush, press the brush release button and slide off.

**Brush
Release**

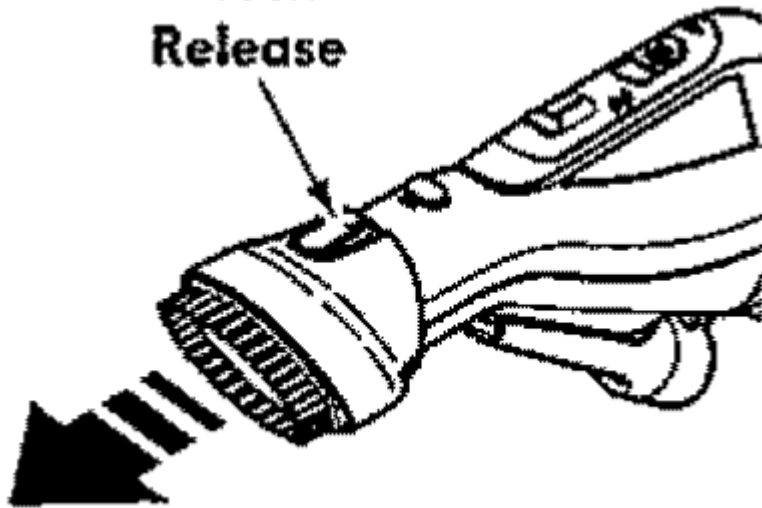

NOTE: To remove floor brush and/or Pet PowerMate0 press the wand release button and slide off.

**Wand
Release**

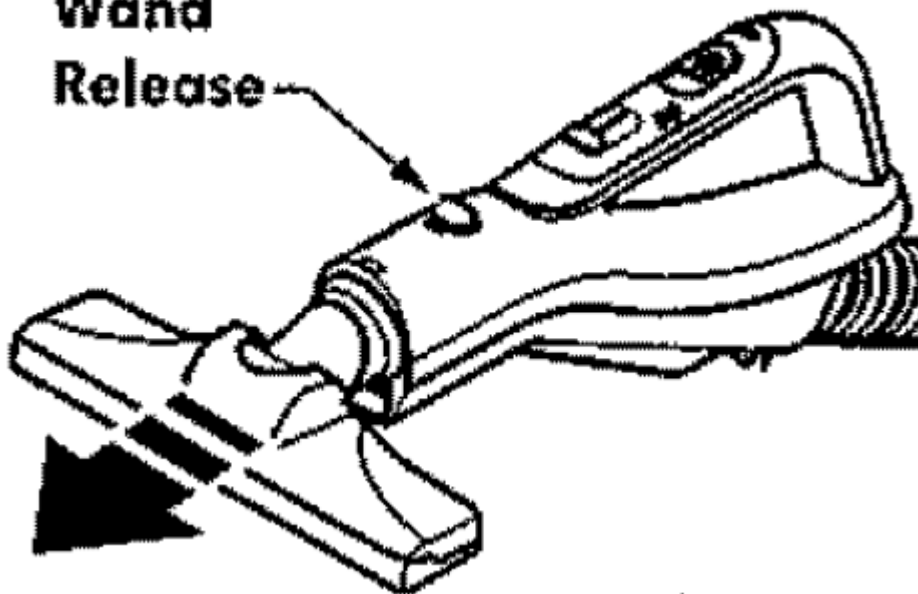

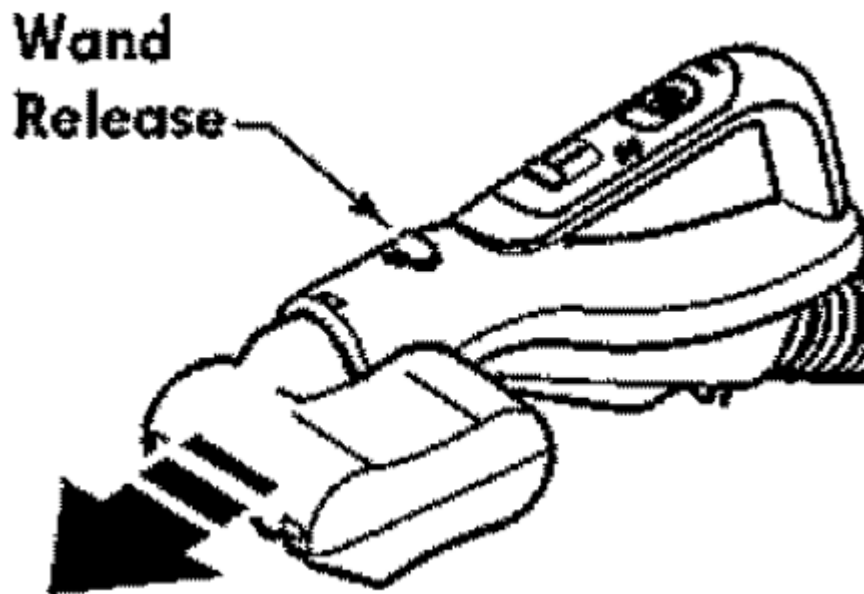

ATTACHMENTS ON WAND

1. To remove wand from PowerMate, lock wand in straight up position.

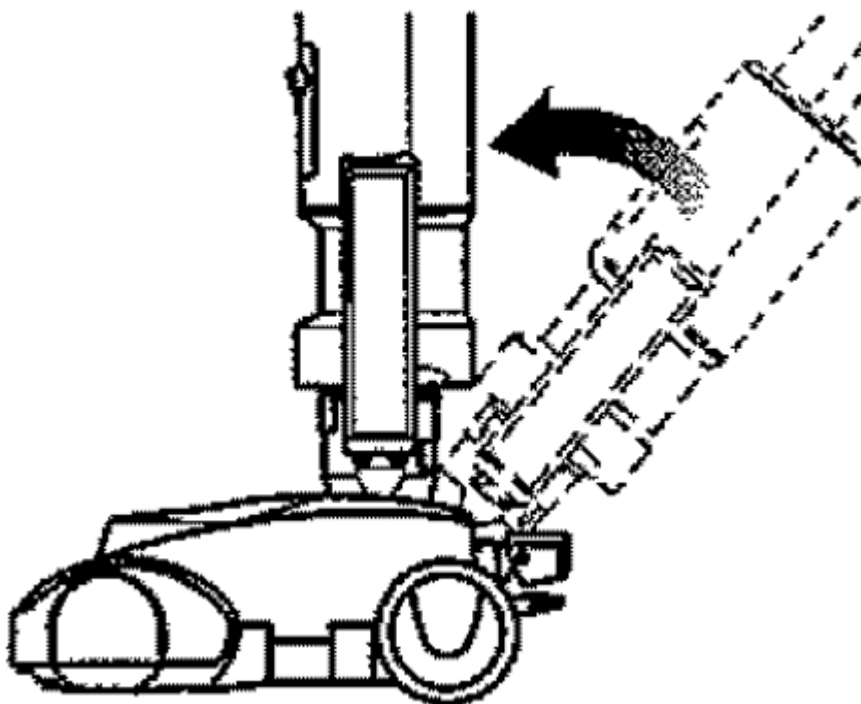

2. Press wand quick-release pedal with foot and pull the wand straight up and out of PowerMate.

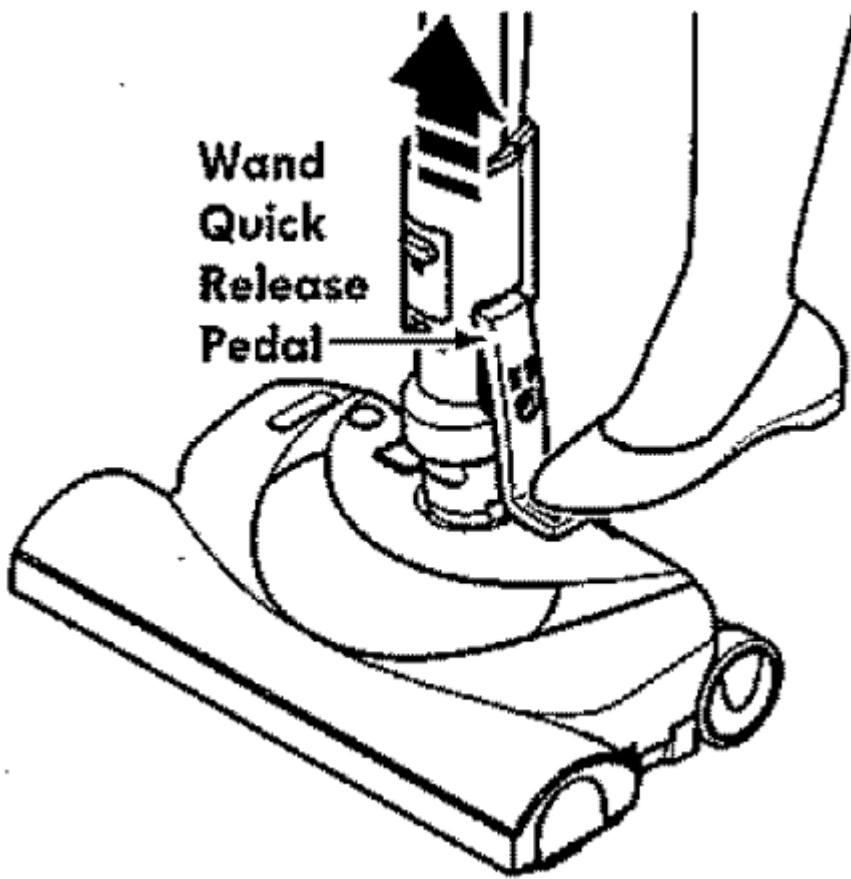

3. Put attachments on wand as needed. See ATTACHMENT USE TABLE (page 16).

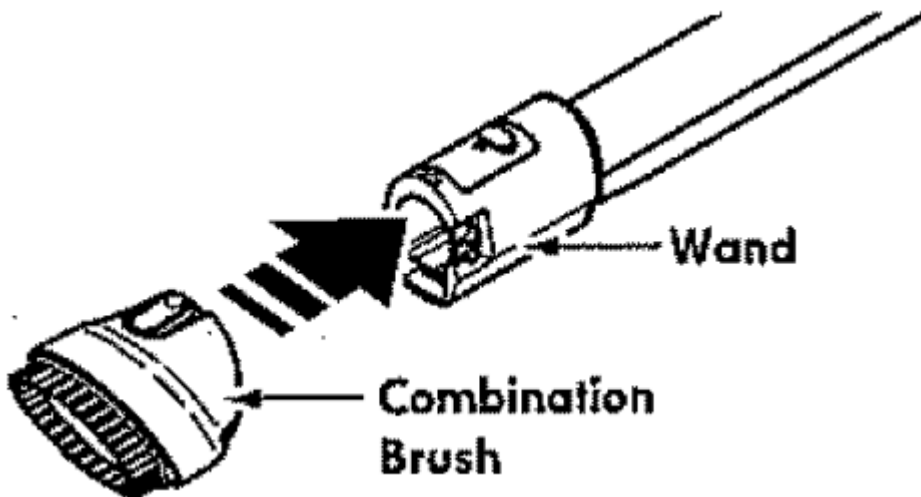

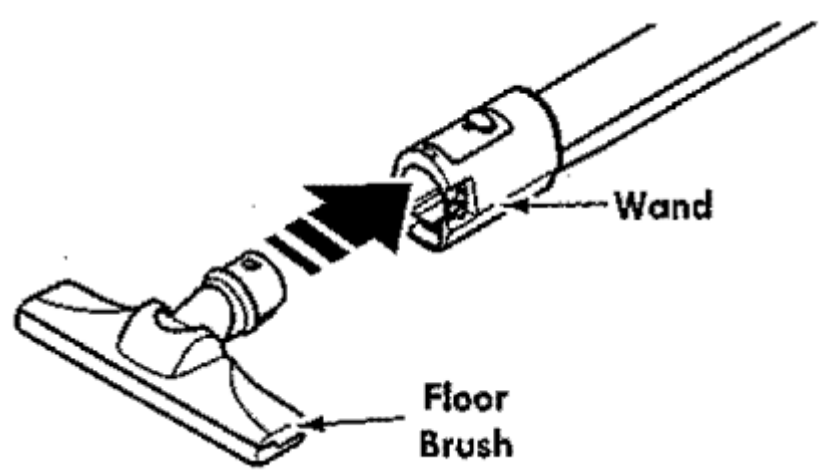
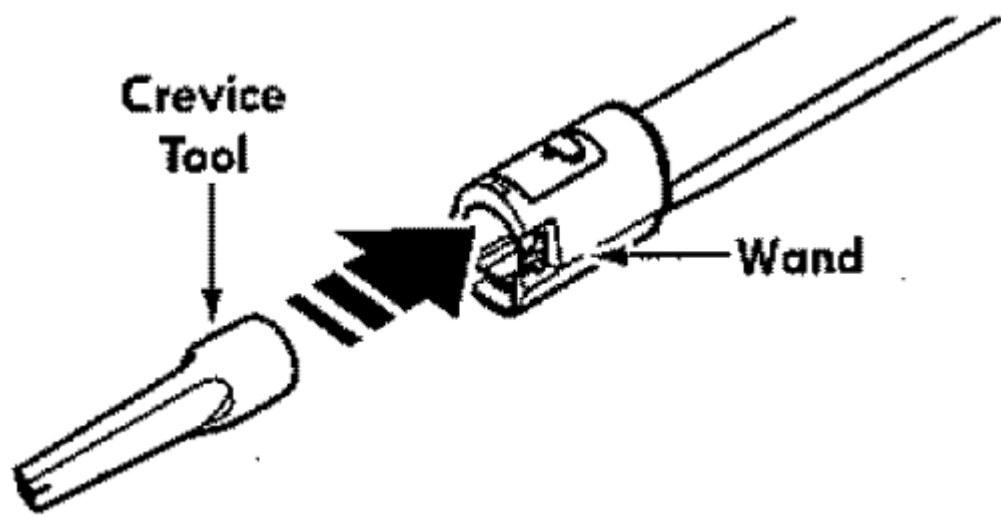
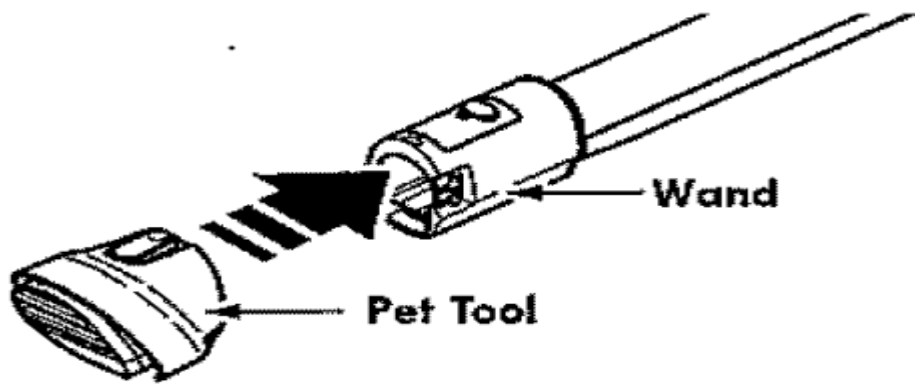

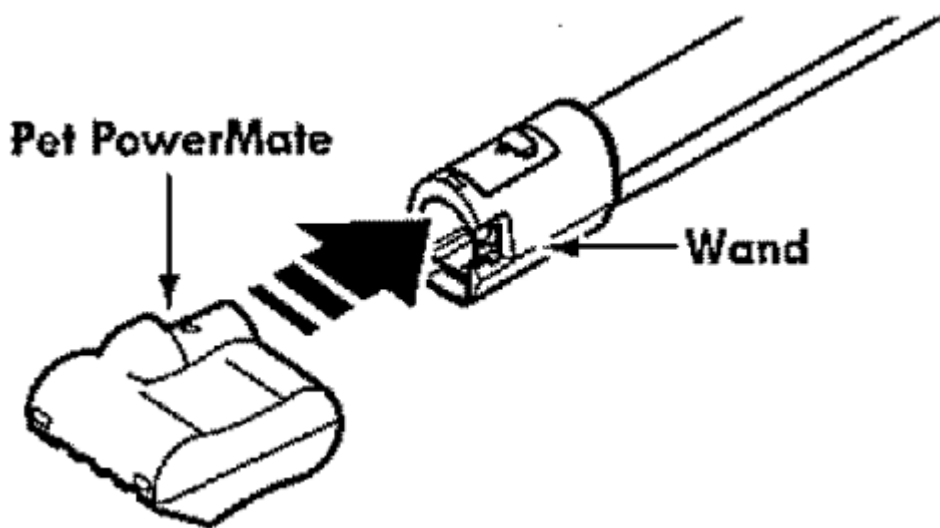

NOTE: To remove combination brush, press the tool release button and slide off,



NOTE: To remove floor brush and/or Pet PowerMate, press the tool release button and slide off,

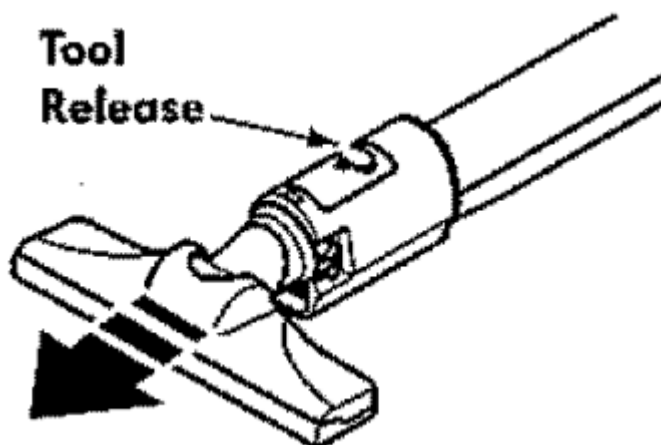

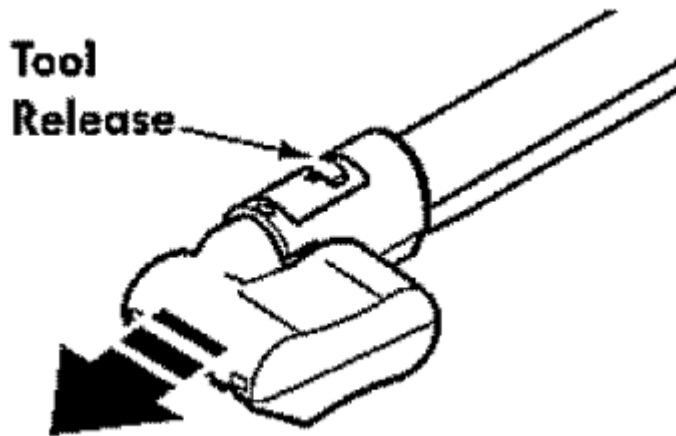

COMBINATION BRUSH

The combination brush uses two tools, the dusting brush and the pet tool. Each is for use on various surfaces. See ATTACHMENT USE TABLE (page 16).

To remove dusting brush or pet tool, release by pressing tab and lifting off the holder,

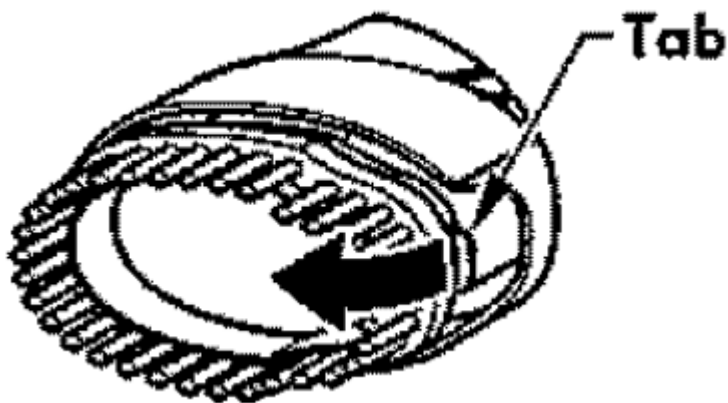

To attach, insert tab on holder into slot on dusting brush or pet tool and press until tab snaps into place.

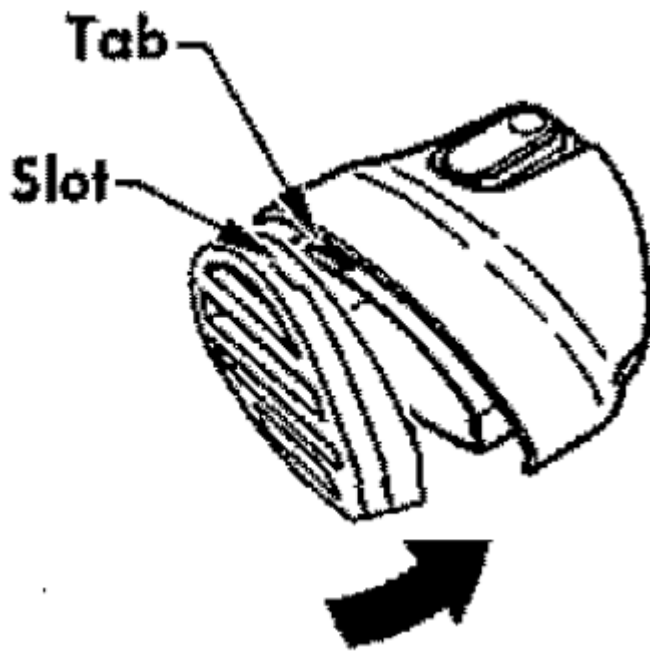





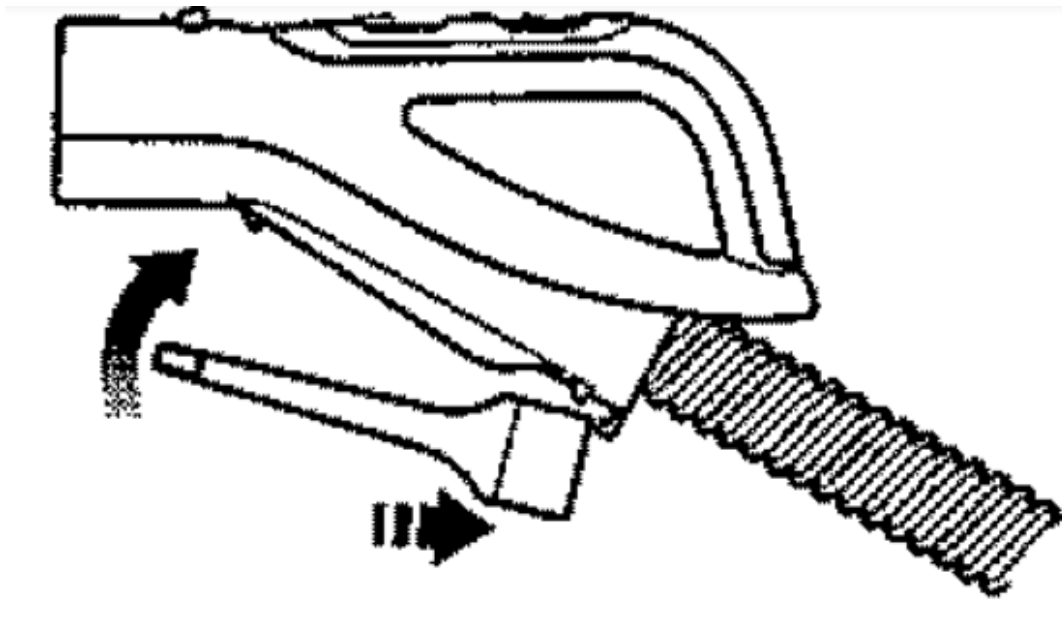

CREVICE TOOL

Attach the crevice tool to the handle storage locations as shown.



Attachment Use Table

ATTACHMENT	CLEANING AREA						
	Furniture ¹	Between Cushions ¹	Drapes ¹	Stairs	Bare Floors	Carpeted Floors/Rugs	Walls
Combination Brush 	✓		✓				✓
Pet Tool ² 	✓		✓				
Crevice Tool 	✓	✓					
Floor Brush 				✓	✓		✓
PowerMate 					✓ ³	✓	
Pet PowerMate ⁴ 	✓			✓		✓	

1. Always clean attachments before using on fabrics.
2. Use the pet tool to remove pet hair from deffcate surfaces, such as upholstery and drapes. DO NOT use on a pet.
3. 3-way On/Off switch should be in FLOOR position. ,
4. Some Models: Pet PowerMate attachment instructionsare included with the products.

Attachment Storage

Pet PowerMate

This canister is equipped with an on-board storage area for a Pet PowerMate attachment.

To Store:

1. Open the Pet PowerMate storage cover.
2. Insert the Pet PowerMate and press down until it clicks into place.
3. Close the lid securely.

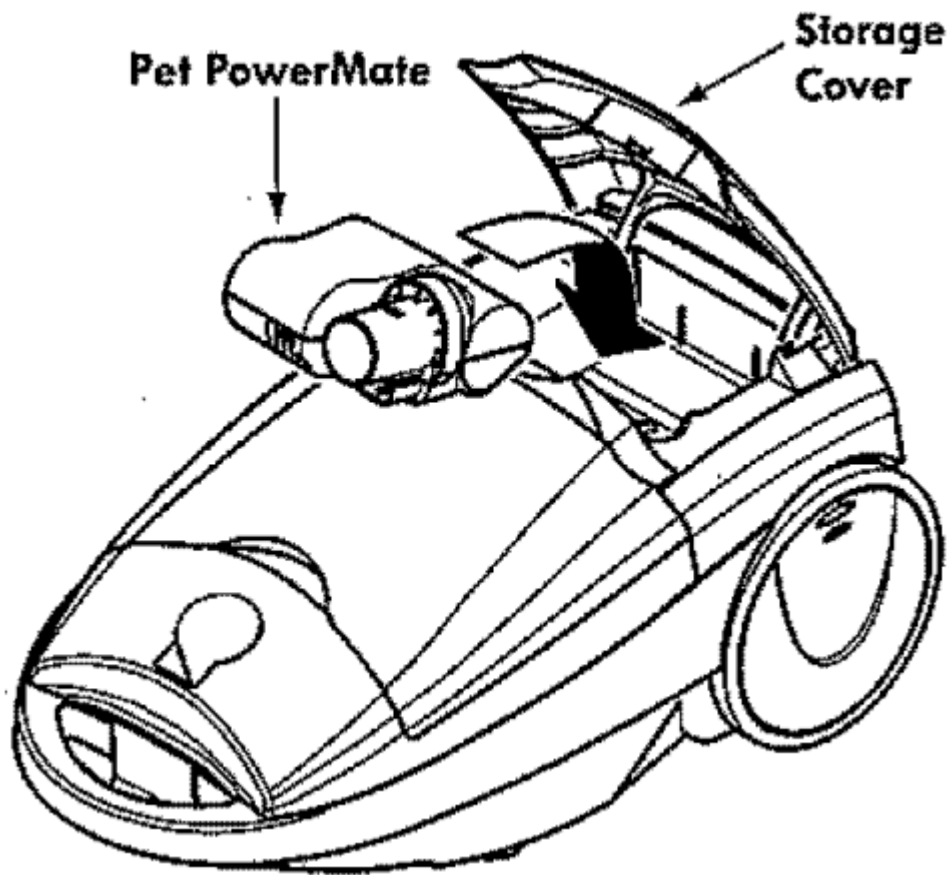

To Remove:

1. Open the storage cover.
2. Remove Pet PowerMate from the storage area.
3. Use as needed. See ATTACHMENTS (page 14-t5) and ATTACHMENT USE TABLE (page 16).

Floor Brush& Pet Tool

This canister is equipped with an on-board storage area for attachments.

To Store:

1. Open the tool storage cover.
2. insert the tool and press down until it clicks into place.
3. Close the lid securely.

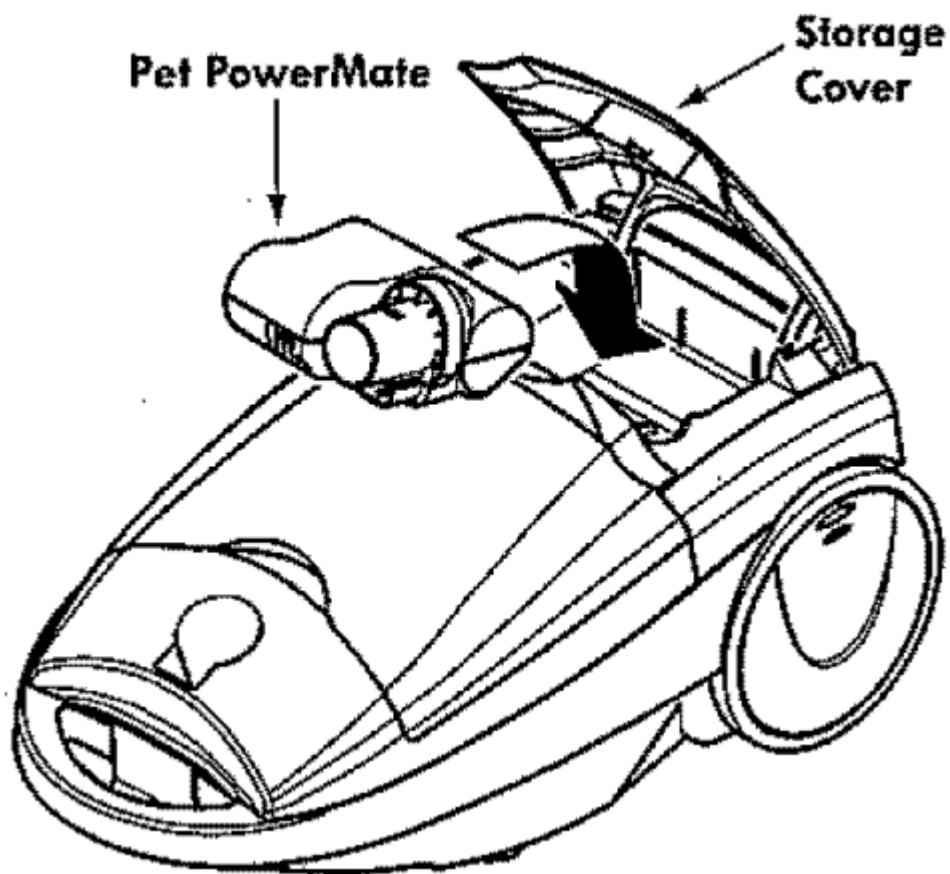

To Remove:

1. Open the storage cover.
2. Remove attachment from the storage area.
3. Use as needed. See ATTACHMENTS (page 14-15) and ATTACHMENT USE TABLE (page 16).

Performance Features

BELTRESET

The PowerMate has built-in protection against motor and belt damage should the agitator jam. If the agitator slows down or stops, the BELT RESET shuts off the PowerMate. The canister motor will continue to run.

To correct problem: Turn off and unplug vacuum cleaner, remove obstruction, then press BELT RESET button.

if the problem persists, have the vacuum cleaner serviced by a Sears or other qualified service agent.

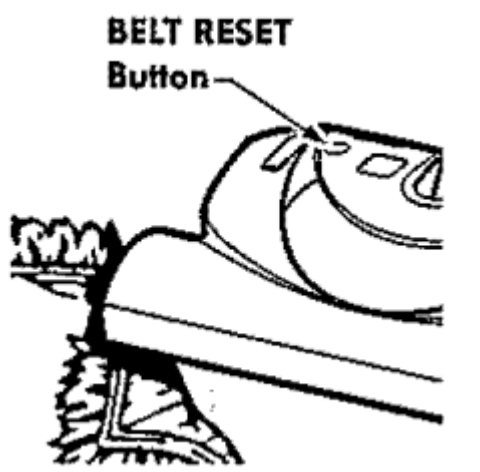

THERMAL PROTECTOR

This vacuum cleaner has a thermal protector which automatically trips to protect the vacuum cleaner from overheating. If a clog prevents the normal flow of air to the motor, the thermal protector turns the motor off automatically. This allows the motor to cool in order to prevent possible damage to the vacuum cleaner.

To correct problem: Turn off and unplug vacuum cleaner to allow the vacuum cleaner to cool and the thermal protector to reset. Check for and remove clogs, if necessary. See REMOVING CLOGS (page 19). Also check and replace any clogged filters. Wait approximately thirty (30) minutes and plug the vacuum cleaner in and turn back on to check if the thermal protector has reset.

CHECK BAG INDICATOR

When the vacuum cleaner is running with normal airflow, the CHECK BAG light is off. The light comes on whenever the bag is full, airflow becomes blocked, or if there is a clog. If that occurs, first check the disposable dust bag. Then check the motor safety filter and other possible clog locations shown in REMOVING CLOGS (page 19).

To correct problem: See the TROUBLESHOOTING table



Canister Care

REMOVING CLOGS

The vacuum cleaner creates suction that picks up dirt. Rapidly moving air carries the dirt to the dust bag through the airflow passages. The dust bag lets the air pass through, while it traps the dirt

For best cleaning results, keep the airflow passage open. Check the starred **(★)** areas occasionally for clogs. Turn off and unplug vacuum cleaner from outlet before checking.

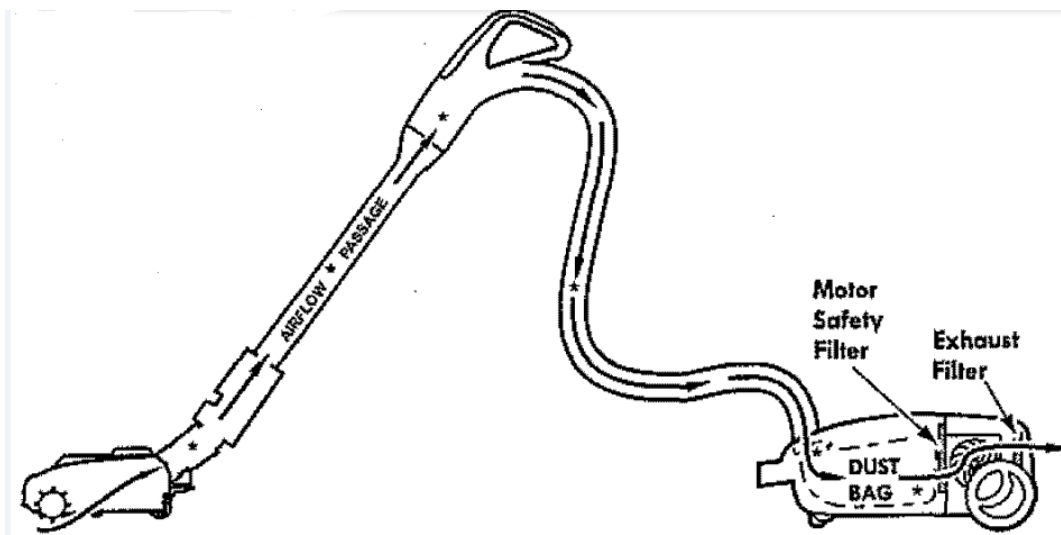

TO CHECK FOR CLOGS:

- Check dust bag and change if full. See BAGCHANGING (page 20).

- Check motor safety filter and exhaust filter. See MOTOR SAFETY FILTER CLEANING (page 21) and EXHAUST FILTER CHANGING (page 22).
- Check PowerMate for any dirt or debris in the belt path area or in the agitator area. Carefully remove any string or debris located on the agitator or end caps. See TO CLEAN AGITATOR (page 24).

If the vacuum cleaner still has poor suction, do the following:

1. Connect the hose to the canister and turn vacuum cleaner on. Check the end of the hose for suction. If there is good suction on the hose handle, there is no clog in the hose. If the suction is bad, remove any dirt or debris in the hose and handle.
2. Connect hose handle to wand. Check the end of the wand for suction, if there is good suction at the end of the wand, there is no clog in the wand. If the suction is bad, remove any dirt or debris in the wand.
3. Check PowerMate swivel. Remove any dirt or debris.

CLEANING EXTERIOR AND ATTACHMENTS

1. Turn off and unplug vacuum cleaner. DO NOT drip water on vacuum cleaner.
2. To clean exterior, or to reduce static electricity and dust build-up, wipe outer surface of vacuum cleaner and attachments. Use a clean, soft cloth that has been dipped in a solution of mild liquid detergent and water, then wrung dry. Wipe dry after cleaning.

BAGCHANGING

REMOVING DUST BAG

1. Turnoff and unplug vacuum cleaner.
2. Remove hose from canister. (See ASSEMBLY INSTRUCTIONS, page 8).
3. Puffhood release out and up

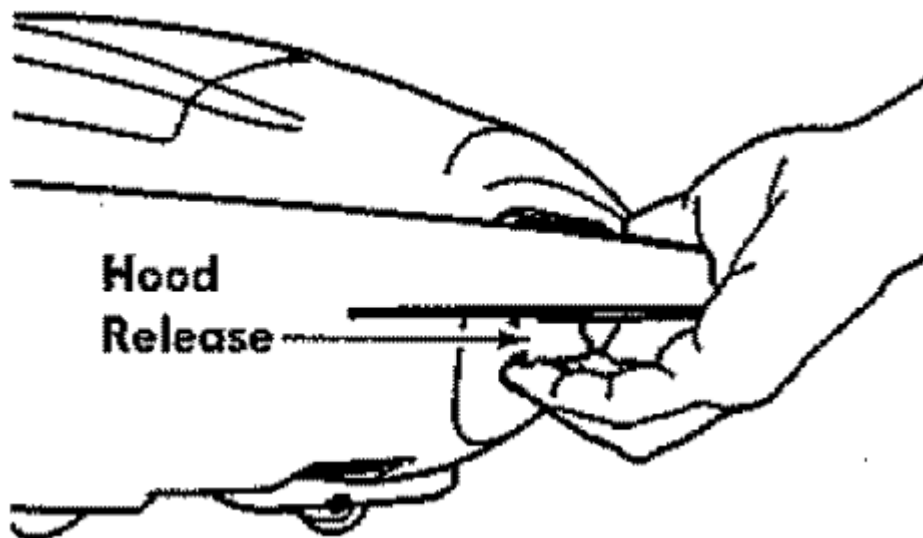

4. Lift canister hood

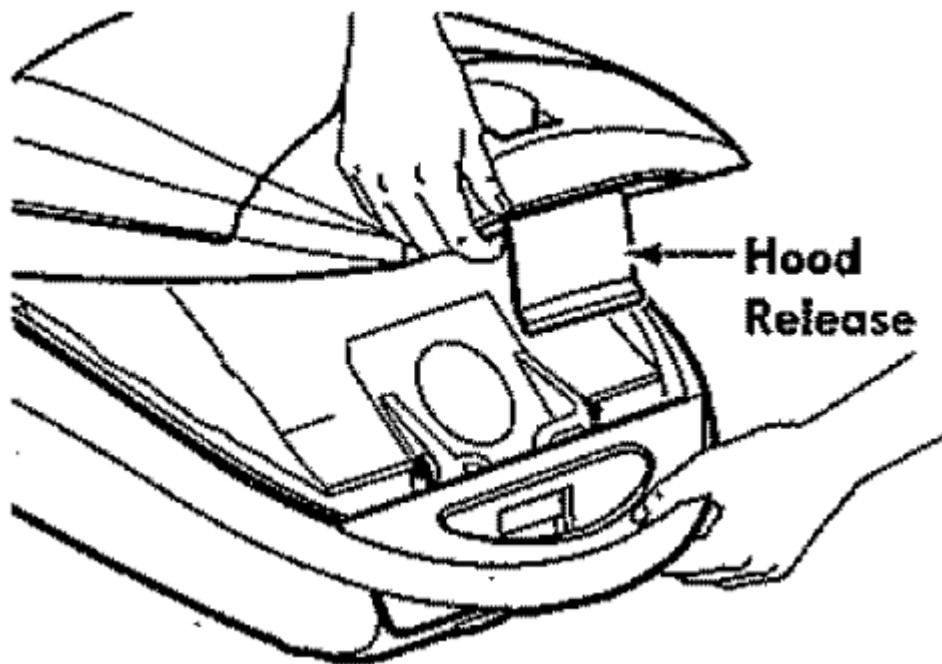

5. Pull bag out of the red bag mount and dispose of dust bag.

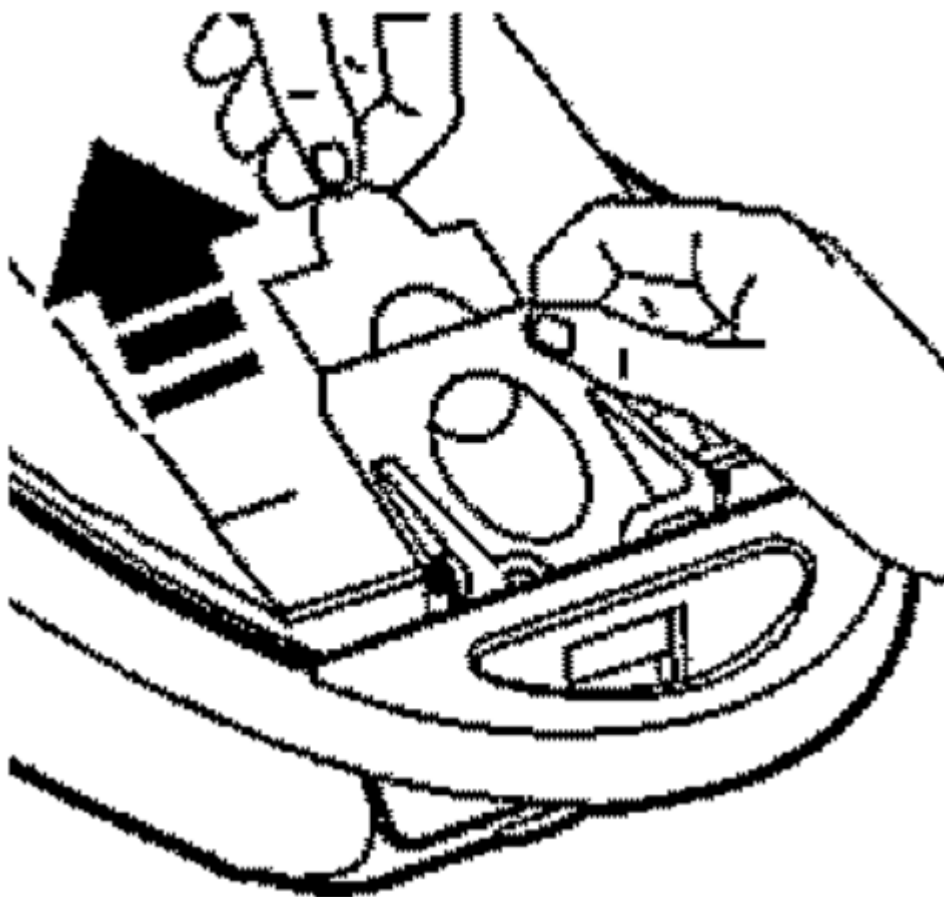

REPLACING DUST BAG

1. Verify that vacuum cleaner is unplugged.
2. Rotate red bag mount down and install bag into slots per illustration, pushing down until the cardboard tab locks into position and the holes align.
3. Tuck the bag securely into the bag cavity so that none of the bag is able to be pinched by the hood.
4. Close and latch canister hood.
5. Insert hose into canister until it snaps in place. (ASSEMBLY INSTRUCTIONS, page 8).

MOTOR SAFETY FILTER CLEANING

Check motor safety filter occasionally and clean when dirty.

- I. Remove the bag as outlined in the BAG CHANGING section.

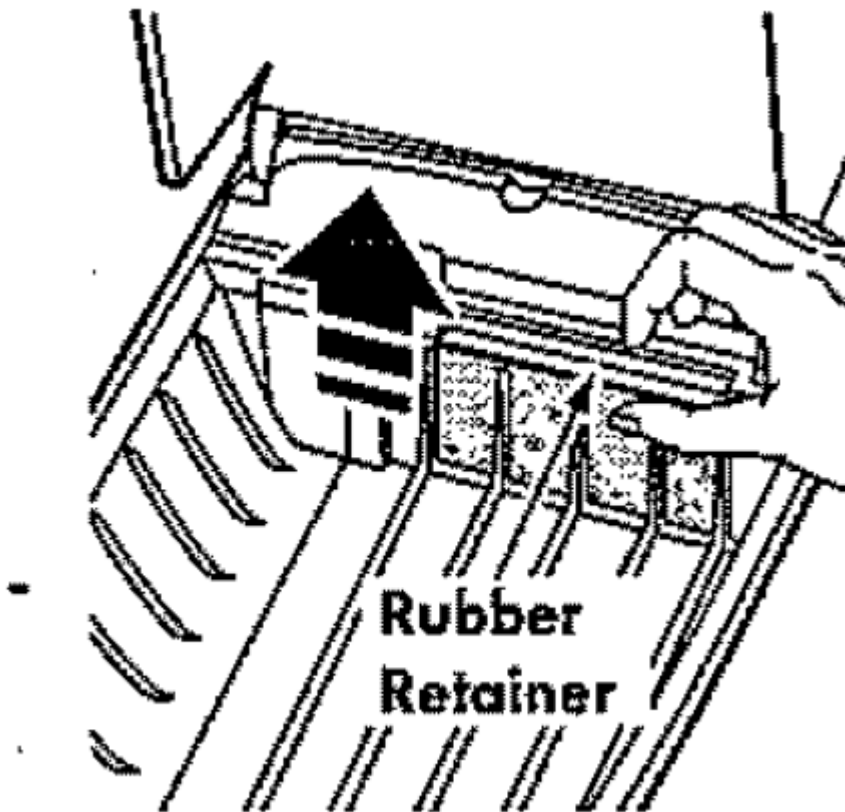

2. Uff the rubber retainer and pull out motor safety filter as shown.
3. Wash filter in warm soapy water, rinse, then dry. Do not clean in dishwasher or install while damp.
4. Replace the filter by sliding it back into place under the ribs in the bag cavity. Tuck filter in so that it fits completely under the rubber retainer.
5. Replace the bag as outlined in the BAG CHANGING section

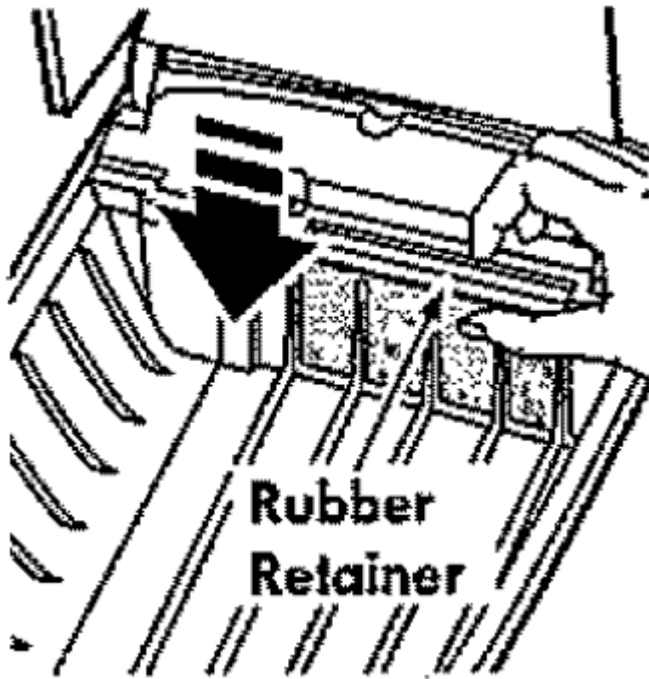

EXHAUST FILTER CHANGING

The exhaust filter cartridge must be replaced regularly. Replace the filter when the entire surface area is covered evenly. The filter CANNOT be washed as it will lose its dust-trapping ability.

1. Pull out and down on the exhaust filter cover to remove from the canister and lay aside.

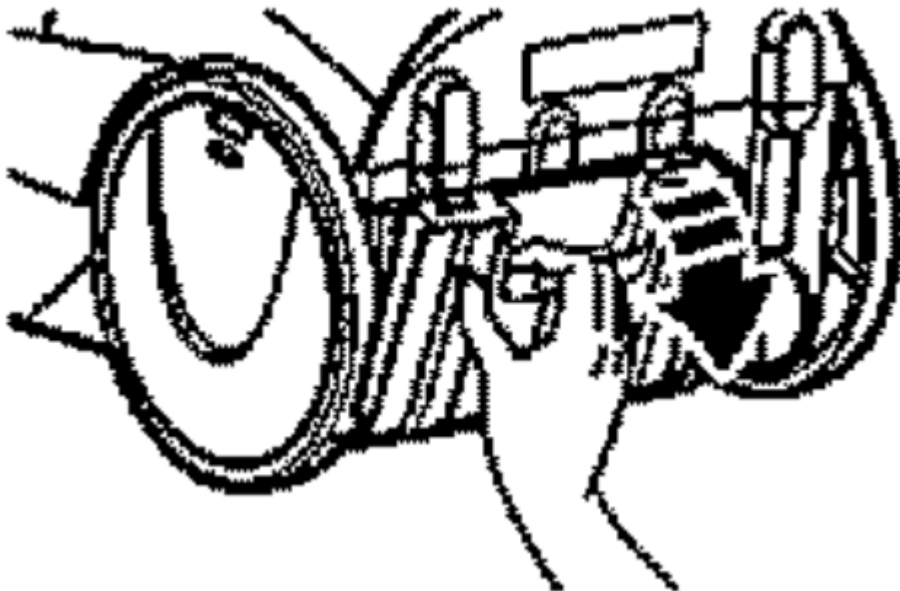

2. Pull the exhaust filter up and out from the rear of the canister.

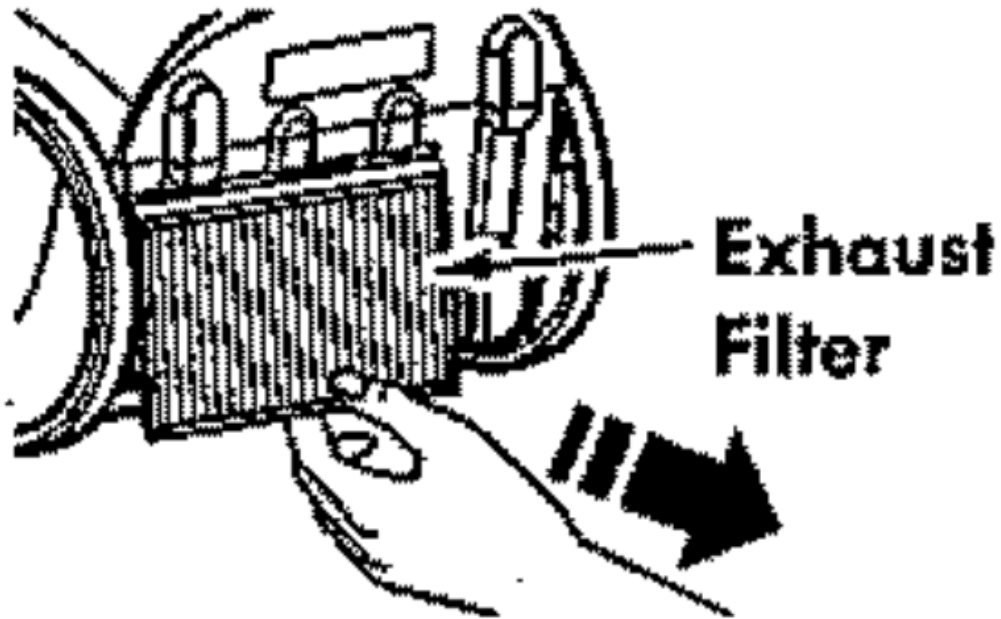

3. Replace the exhaust filter cartridge. Place the new filter into the canister with the foam seal facing towards the canister.

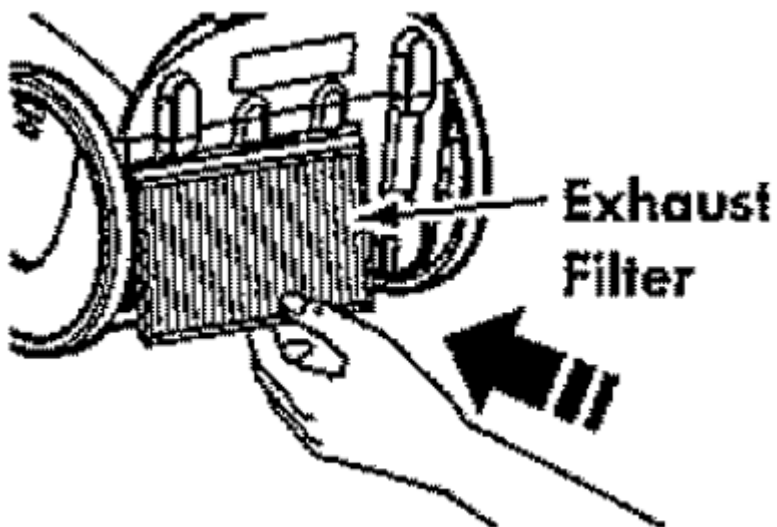

4. Replace the exhaust filter cover by placing the two tabs on the filter cover into the slots on the canister and rotate into place until it snaps closed.

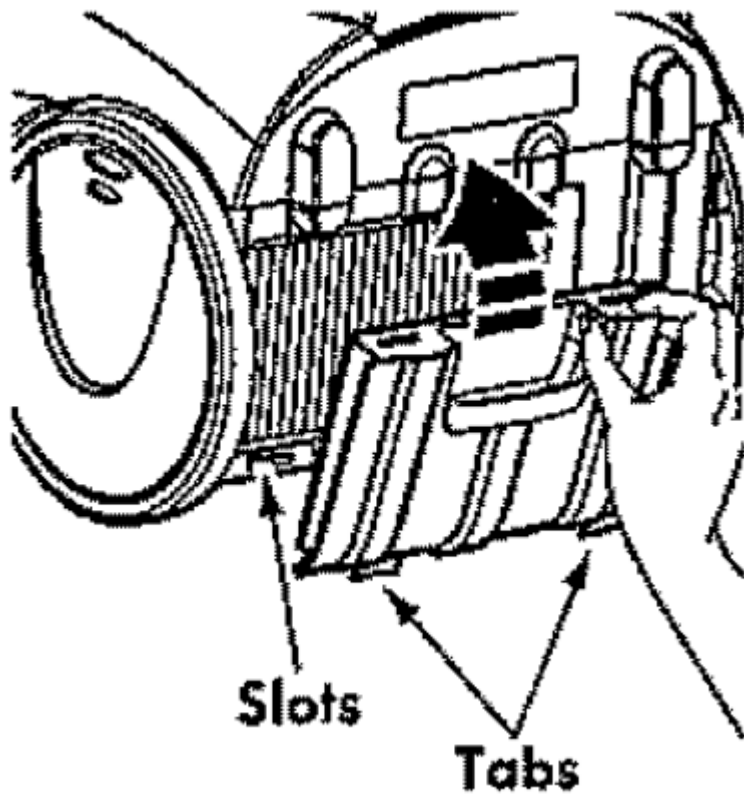

PowerMate ®Care

BELT CHANGING AND AGITATOR CLEANING

TO REMOVE BELT

1. Turn off and unplug vacuum cleaner.
2. Turn PowerMate upside down.
3. Unscrew the two (2) PowerMate cover screws.

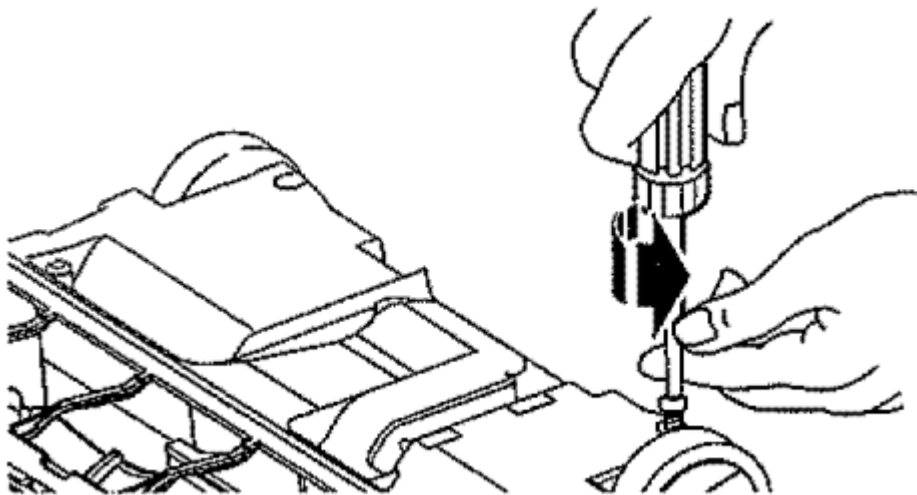

4. Turn PowerMate top side up. Press handle release pedal and lower the swivel Lift rear latches up.

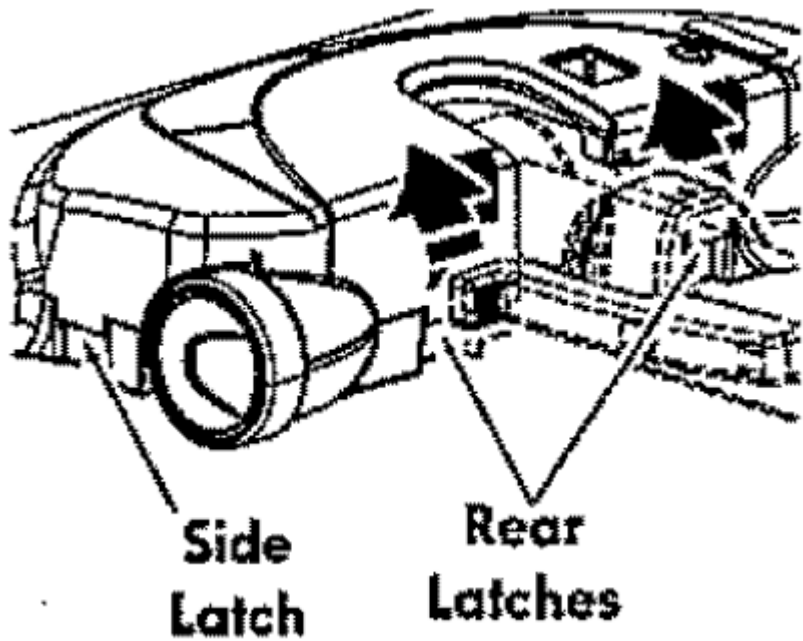

5. To remove cover, grasp the sides and pull out.

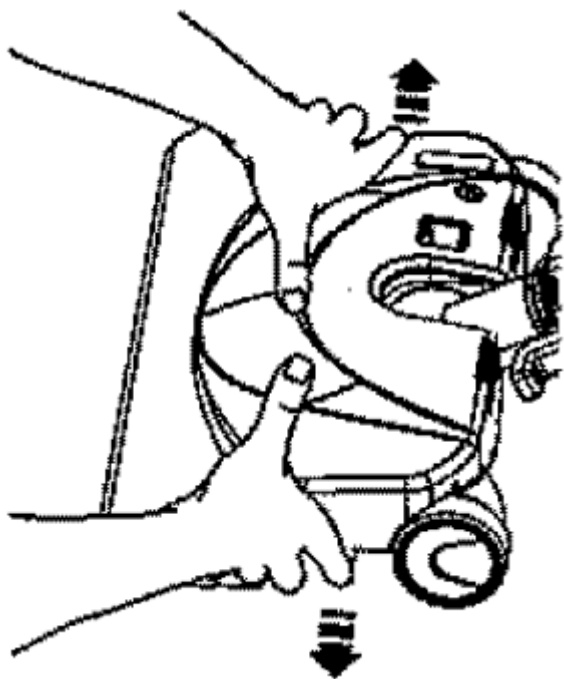

6. Lift agitator assembly out and remove worn belt.

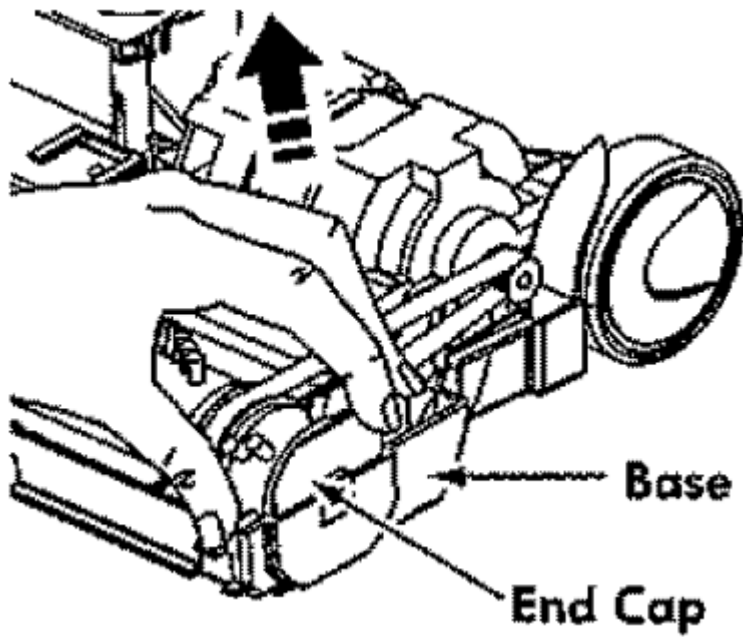

7. Check and clean end cap areas. See AGITATOR ASSEMBLY (page 24) for picture of complete agitator assembly.

TO CLEAN AGITATOR:

The agitator must also be cleaned according to the following schedule :

Vacuum Cleaner Use	Clean Agilator
HEAVY- (used daily)	every week
MODERATE -(used 2-3 times/week)	every month
LIGHT - (used 1 time/week)	every 2 months

IMPORTANT : Disconnect vacuum cleaner from electrical outlet. Check and remove hair, string and lint build-up frequently in the PowerMate agitator and end cap areas.

Remove any dirt or debris in the belt path area or in the brush roller area.

Carefully remove any string or debris located on the agitator or end caps.



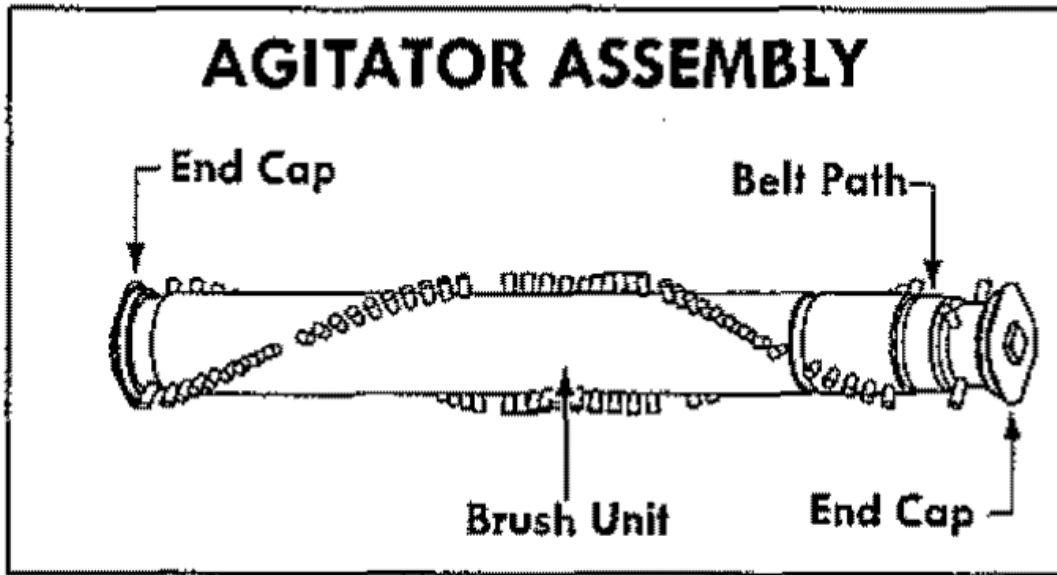
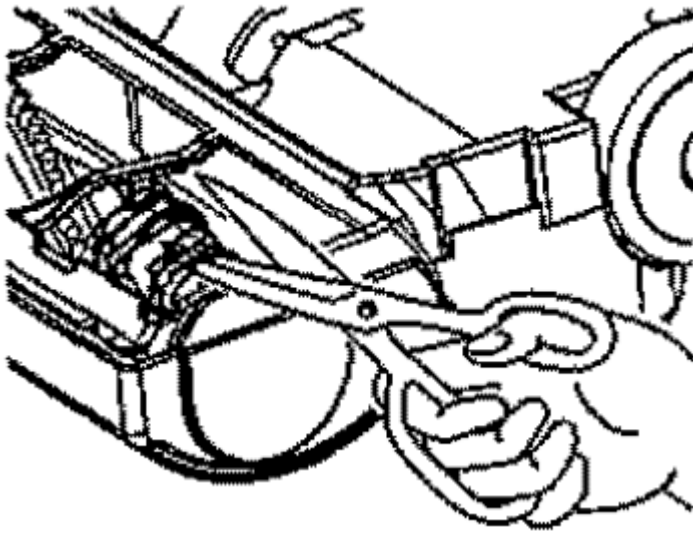

TO REPLACE BELT

1. Install new belt over motor drive, then over belt path.

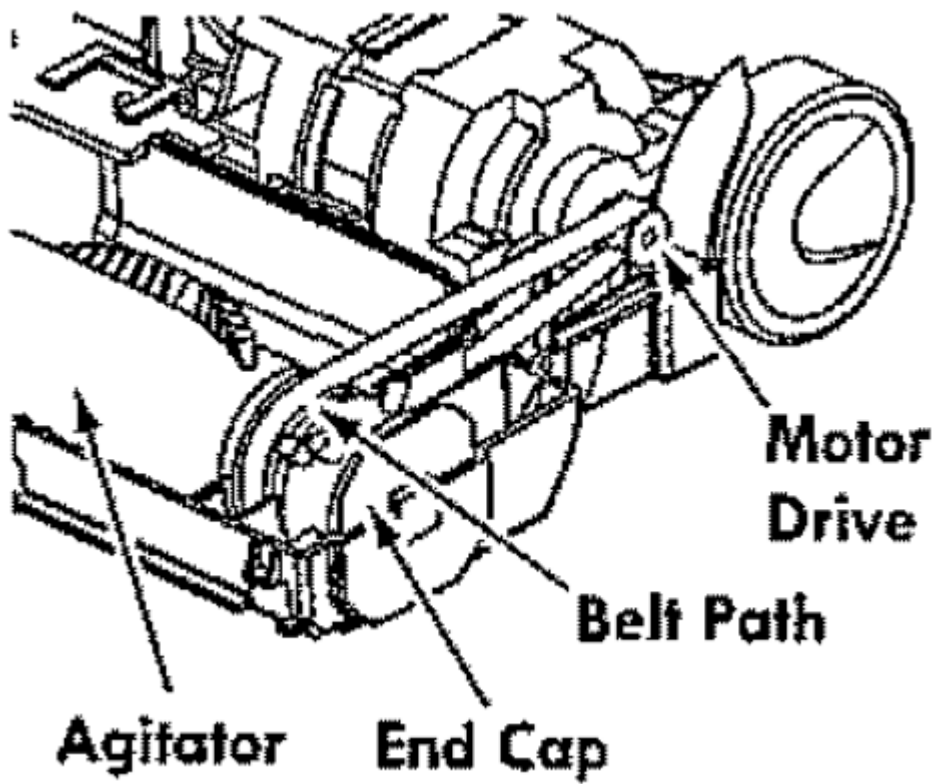

2. Place agi-tatar assembly back into PowerMate.

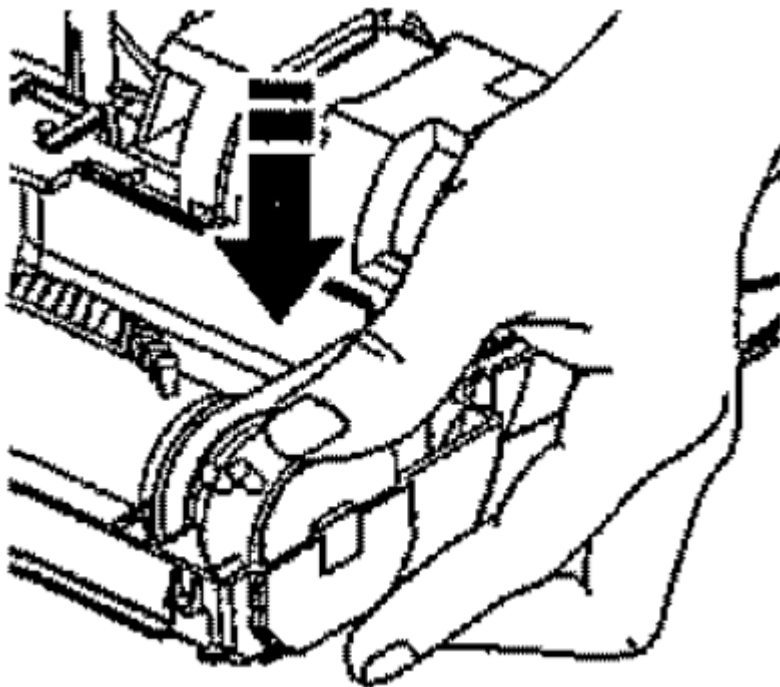

3, Verify that end cap aspressed firmly into position.

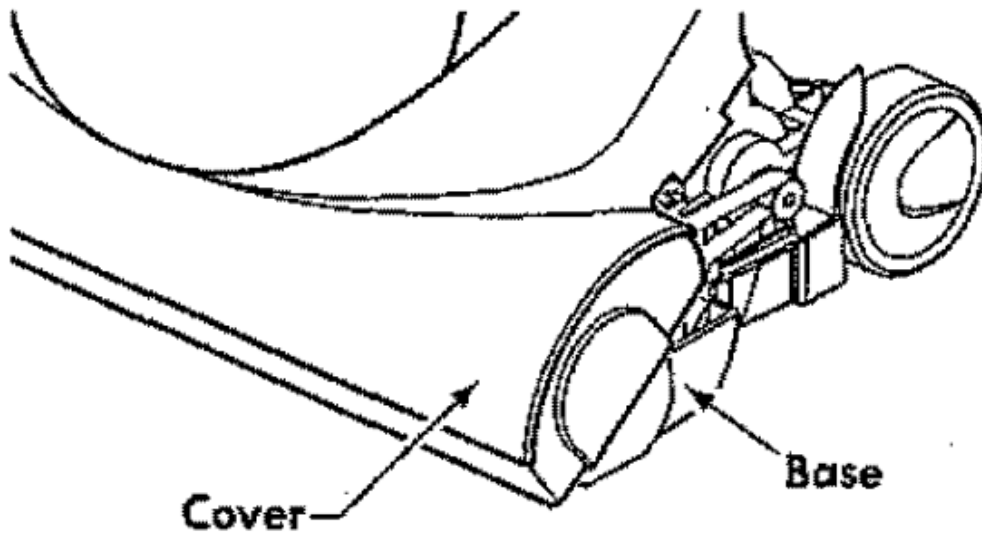

Line up front of cover and base. Rest cover on front edge of base as shown.

4. Rotate cover back. Press cover firmly until side and rear latches snap into place.

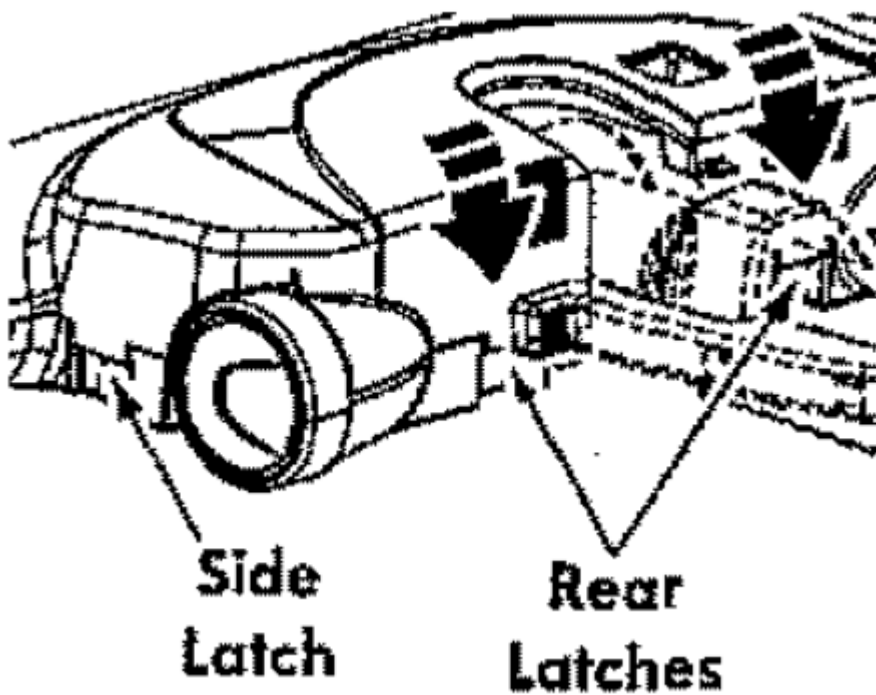

Make sure there is no gap between the cover and base.

5. Turn PowerMate upside down and replace two (2) cover screws.

LIGHT BULB CHANGING

1. Remove PowerMate covers as shown in BELT CHANGING AND AGITATOR CLEANING (page 23-24) section.

2. Remove the light bulb by pulling straight out.

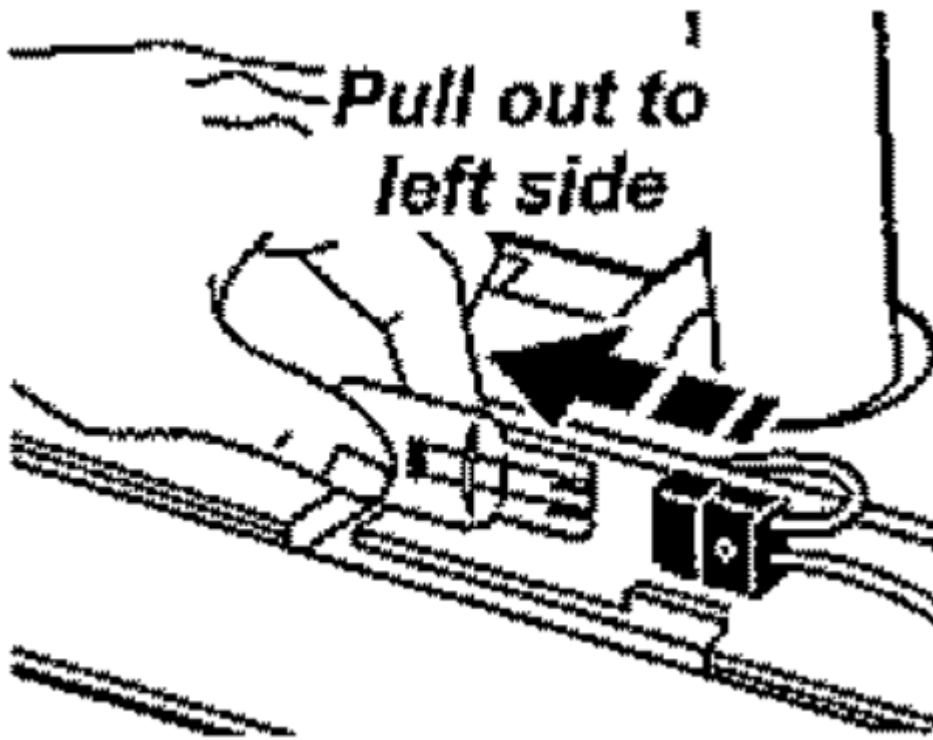

3. To replace the light bulb carefully insert fully into slot,

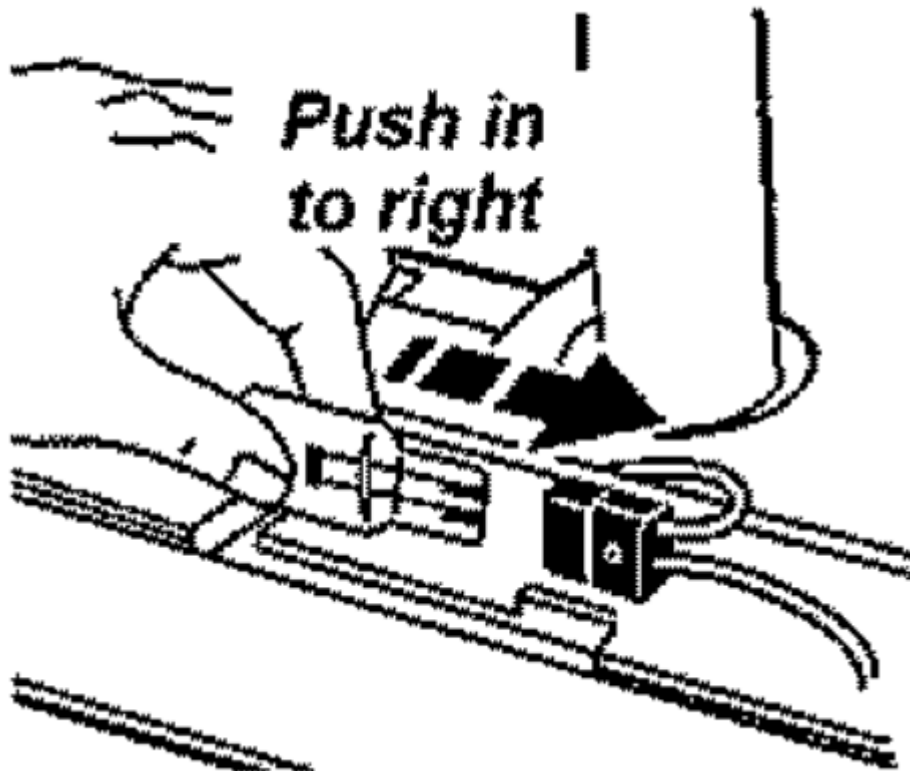

4. Reinstall PowerMate cover as shown in BELT

AGITATOR SERVICING

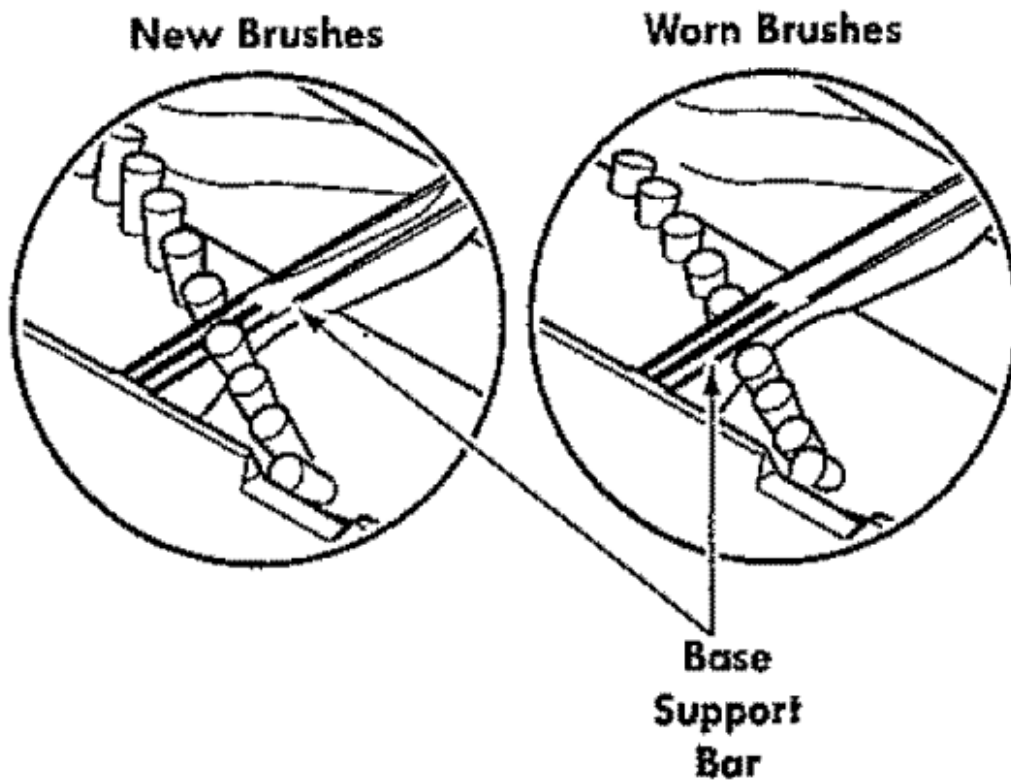

TO CHECK THE BRUSHES

When brushes are worn to the level of the base support bars, replace the agitator assembly.

TO REPLACE AGITATOR ASSEMBLY

1. Remove PowerMate cover, belt and agitator assembly. See "To Remove Belt" in BELT CHANGING AND AGITATOR CLEANING (page 23-24).
2. Replace agitator assembly, See your separate repair parts list for part number.
3. Reinstall belt and PowerMate cover. See "To replace belt" in BELT CHANGING AND AGITATOR CLEANING (page 23-24).

Troubleshooting



PROBLEM	POSSIBLE	POSSIBLE SOLUTION
Vacuum cleaner won't start.	<ol style="list-style-type: none"> 1. Unplugged at wall outlet 2. Tripped circuit breaker/blown fuse at household service panel. 3. Loose hose electrical connection 	<ol style="list-style-type: none"> 1. Plug in firmly, push, ON/OFF switch to on. 2. Reset circuit breaker or replace fuse 3. Reconnect hose ends, (page 8)
Poor job of dirt pick-up,	<ol style="list-style-type: none"> 1. Full or clogged dust bag. 2. Clogged airflow passages, 3. Dirty filters. 4. Wrong pile height setting, 5. Wrong power level selected 6. Hole in hose. 7. Worn PowerMate agitator. 8. Worn or broken belt. 9. Dirty agitator or end caps, 10. Tripped overload protector in PowerMate, 	<ol style="list-style-type: none"> 1. Change bag. (page 20) 2. Clear airflow passages (page 19) 3. Clean/replace filters. (page 21-22) 4. Adjust setting. (page 13) 5. Adjust control Tripped circuit. (page 11) 6. Replace hose. 7. Change agitator. (pages 23-26) 8 & 9. See BELT CHANGING AND AGITATOR CLEANING (page 23-24). 10. Remove any items that may be caught or jammed, then reset. If vacuum cleaner starts and stops again, clean agitator and end caps then reset. (page 18, 25)
Vacuum cleaner starts but shuts off,	<ol style="list-style-type: none"> 1. Hose or hood electrical connections, 2. Tripped overload protector in PowerMate. 	<ol style="list-style-type: none"> 1. Check connections, and reconnect hose ends. (page 8)



	<p>3. Tripped thermal protector in canister.</p>	<p>2. Remove any items that may be caught or jammed_ then reset. If vacuum cleaner starts.d stops again, clean agitator and endcaps, then reset.(page 18)</p> <p>3. See PERFORMANCE FEATURES- "Thermal Protector"(page t8).</p>
<p>PowerMate will not run when attached.</p>	<p>1. PowerMateconnections unplugged,</p> <p>2. Worn or broken bell</p> <p>3. Dirty agitator or end caps.</p> <p>4. Tripped overload protector in PowerMate.</p> <p>5. Switch not in CARPETposition.</p>	<p>1. Plugin firmly.</p> <p>2&3. See BELT CHANGING AND AGITATOR CLEANING (pages 23-24).</p> <p>4. Remove any items that may be caught or jammed, then reset. If vacuum cleaner starts and stops again, clear, agitator and end caps, then reset.(page 18,25)</p> <p>5. Move switch to CARPETposition. (page 11)</p>
<p>CHECK BAG Indicator activates.</p>	<p>1. Fullor clogged dust bag.</p> <p>2. Dirty filters</p> <p>3. Blockedairflow passage</p> <p>4. Certain attach meant tools.</p>	<p>1. Change bag. (page 20)</p> <p>2. Clean/replace filters. (page 21)</p> <p>3. Clear blockage from airflow passage.(page 19)</p> <p>4. This is normal. Lights should go off when tool is removed.</p>



Vacuum cleaner picks up moveable-rugs - or-FowerMate pushes too hard.	<ol style="list-style-type: none"> 1. Wrong pile height setting. 2. Suction too strong. 	<ol style="list-style-type: none"> 1. Adjust setting,(page 13) 2. Select lower Power Level.(page 11)
Cordwon't rewind.	<ol style="list-style-type: none"> 1. Dirty power cord. 2. Cord jammed. 	<ol style="list-style-type: none"> 1. Clean the power cord. 2. Pull out cord and rewind.[page 10)
Vacuum cleaner leaves marks on carpet_	<ol style="list-style-type: none"> 1. Wrong vacuuming pattern. 	<ol style="list-style-type: none"> 1. See VACUUMING TIPS(page 12).

Warning

This content is compiled from multiple sources and is provided for reference purposes only. It may not be complete or fully applicable to all situations. If you are unable to resolve your issue, please contact the product manufacturer or an authorized service provider for official support.