

OPERATION

Parts and Functions

Exterior

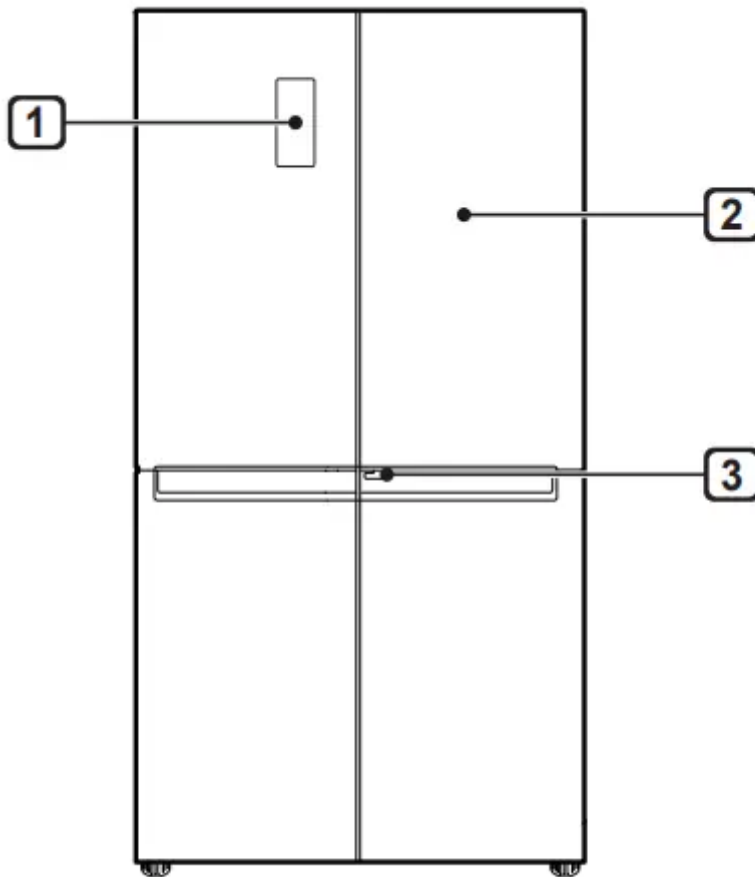

1. Control Panel

Sets the fridge and freezer temperatures.

2. Door-in-Door (*)

The Door-in-Door is a double layered door system. It can be opened individually or together with the main door. You can conveniently locate and access your favourite snacks or food items.

3. Door-in-Door Lever (*)

You can open the Door-in-Door by pulling the lever at the bottom of the door.

NOTE

- (*) means that this feature varies depending on the model purchased.
- The appearance or components of the appliance may differ from model to mode

Interior

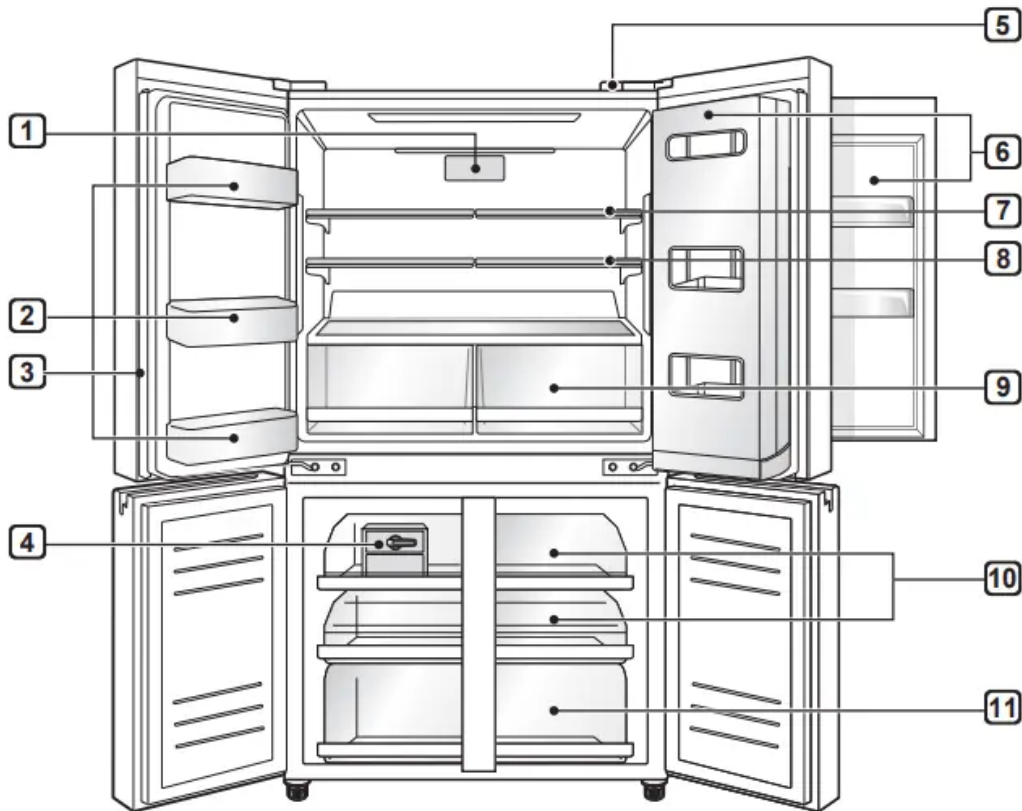

1. Pure N Fresh

This function reduces and removes odors inside the fridge compartment.

2. Fridge Door Basket

This is where small packages of refrigerated foods, drinks and sauce containers are stored.

3. Folding Door Mullion

This blocks the cold air of the fridge from escaping when the doors are closed.

CAUTION

To reduce the risk of scratching the door or breaking the center door mullion, make sure that the fridge door mullion is always folded in.

The door alarm will sound every 30 seconds if the door remains open longer than one minute. Ensure that the folding mullion is folded in before closing the left-hand door.

4. Moving Ice Maker

This is where ice is produced and stored.

5. Smart Diagnosis Unit

Use this function when contacting LG Electronics customer information centre to help make an accurate diagnosis when the appliance operates abnormally or a failure occurs.

6. Door-in-Door (*)

A convenient storage area for frequently used items that require easy access.

7. Adjustable Fridge Shelf

Shelves are adjustable to meet individual storage needs.

8. Folding Shelf (*)

Shelf is adjustable to meet individual storage needs.

9. Vegetable Drawer

This is where fruits and vegetables are stored to remain fresh for as long as possible.

10. Freezer Tray

This is where frozen foods such as the meat, fish, and ice cream, can be stored. • The sliding trays allow easy access and convenience of use.

11. Freezer Drawer

This is for long-term storage of frozen items. • Preserve small packaged frozen food or frequently-taken out foods. To use larger space, remove drawers.

NOTE

- (*) means that this feature varies depending on the model purchased.

Notes for Operation

- Users should keep in mind that frost can form. If the door is not closed completely, if the humidity is high during the summer, or if the freezer door is opened frequently. Condensation build up within food storage wrappers is also caused by the same conditions.
- Ensure there is sufficient space between food stored on the shelf or door basket to allow the door to close completely.
- Opening the door lets warm air enter the appliance, and may cause the internal temperature to rise and condensation to form.
- If you are leaving the appliance turned off for an extended period of time, remove all food and unplug the power cord. Clean the interior, and leave the doors slightly ajar to prevent mold from growing in the appliance.

Suggestion for Energy Saving

- Ensure there is sufficient space between stored foods. This allows cold air to be circulated evenly and lowers electricity bills.
- Store hot food only after it has cooled in order to prevent dew or frost.
- When storing food in the freezer compartment, set the freezer temperature lower than the temperature indicated on the food.



- Do not put food near the temperature sensor of the fridge compartment. Keep a distance of at least 3 cm from the sensor.
- Note that a temperature rise after defrosting has a permissible range in the appliance specifications. If you wish to minimise the impact this may have on the food storage due to a temperature rise, seal or wrap the stored food in several layers.
- The automatic defrosting system in the appliance ensures that the compartment remains free of ice buildup under normal operating conditions.

Storing Foods Effectively

- Store frozen food or refrigerated food inside sealed containers. It is normal for condensation or frost to form inside sealed containers due to the moisture already in the container or bag prior to it being sealed.
- Check the expiration date and label (storage instructions) before storing food in the appliance.
- Do not store food for a long period of time (more than four weeks) if it spoils easily at a low temperature.
- Place the refrigerated food or frozen food in each fridge or freezer compartment immediately after purchasing.
- Avoid refreezing any food which has been completely thawed. Freezing any food which has been completely thawed again will lower its taste and nutrition.
- Do not wrap and store vegetables with newspaper. Printing material of newspaper or other foreign substances may smear and contaminate food.
- Do not overfill the appliance. Cold air can not circulate properly if the appliance is overfilled.
- If you set an excessively low temperature for food, it may become frozen. Do not set a temperature lower than the required temperature for the food to be stored correctly.
- If there are chill compartments in the appliance, do not store vegetables and fruits with higher moisture content in the chill compartments as they may freeze due to the lower temperature.

Max Freezing Capacity

- The Express Freeze function will allow the freezer to its maximum freezing capacity. This generally takes up to seven hours, however, it will automatically turn off after a given time and can also be turned off manually at any given time.
- To get better air circulation, insert all inner parts like baskets, drawers, and shelves.

Maximum Storage

- To get better air circulation, insert all drawers.
- If large quantities of food are to be stored, all the freezer drawers shall be taken out of the appliance except the bottom one and the food shall be stacked directly on the freezer shelves in freezer compartment.

NOTE

- To remove the drawers, first pick the food out of drawers. Then use the handle of drawers, pull out the drawers carefully. It may cause injury.
- The shape of each drawer may be different, insert in the right position.

Using Control Panel

Units and Functions

1. Fridge
 - This sets the fridge target temperature.
2. Freezer
 - This sets the freezer target temperature.
3. Pure N Fresh
 - This function reduces and removes odors inside the fridge compartment.

NOTE

- After changing the filter, push and hold the Pure N Fresh button for three seconds to reset the filter replacement reminder indicator.
4. Express Freeze
 - This sets Express Freeze functions.
 5. Wi-Fi
 - This sets the refrigerator to connect to your home's Wi-Fi network.
 6. Lock
 - This locks the buttons on the control panel.

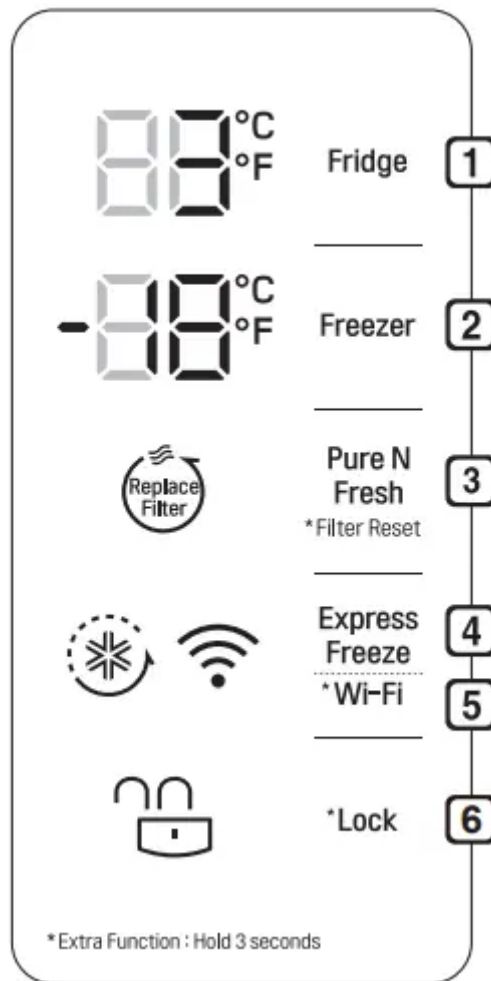

NOTE

- The actual control panel may differ from model to model.
- The control panel will turn off automatically for energy saving.
- If there is any finger or skin contacts to the control panel while cleaning it, the button function may operate.

Setting the Temperature

This sets the fridge temperature or freezer temperature.

- Press the Fridge button or Freezer button to adjust the temperature.
- The initial temperature is set. – Fridge : 3 °C – Freezer : -18 °C
- The temperature can be adjusted. – Fridge : from 0 °C to 6 °C – Freezer : from -24 °C to -16 °C
- The actual inner temperature varies depending on the food status, as the indicated setting temperature is a target temperature, not actual temperature within the appliance.

NOTE

- The default temperature setting may vary depending on the appliance.
- Wait until two or three hours have passed after connecting the appliance to the outlet before storing food in the appliance.
- For ice making in normal climates, the freezer temperature should be set to -18 °C or colder.

Setting Express Freeze

- The function can quickly freeze a large amount of ice or frozen foods.
- When you press the **Express Freeze** button, the **Express Freeze** icon lights on the control panel.
- The function is enabled and disabled in turn each time you press the button.
- The Express Freeze function automatically terminates after a specific period has passed.

Setting and Resetting Lock

- This locks the buttons on the control panel.
- When you press the Lock button for 3 seconds, the Lock/Unlock icon on the control panel lights. The function is enabled and disabled in turn each time you press the button.
- If you press a button other than lock when the lock is set, the button will not function.
- To change a setting, first press the Lock button for 3 seconds to disable the function.

NOTE

- The Lock function does not disable the dispenser operation.
- When you press a button other than lock when the lock is set, the Lock/Unlock icon on the control panel will flash 3 times.

Folding Door Mullion

This door mullion prevents cold air from leaking from the appliance.

CAUTION

- The door alarm will sound every 30 seconds if the door remains open longer than one minute. Ensure that the folding mullion is folded in before closing the left-hand door.



- To reduce the risk of door scratches and breaking the centre door mullion, make sure that the appliance door mullion is always folded in.

Door in Door (*)

Pull the lever at the bottom of the door upwards until the door in door opens.

There is plenty of storage space inside the door in door and its surrounding baskets, allowing you to store food in an organized manner.

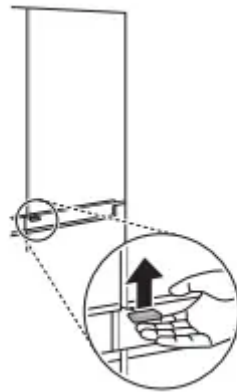

Removing the Case from the Door in Door

Hold the case from inside the door in door with both hands and remove it by lifting it upward.



Refitting the Door in Door Case

Mount them in the reverse order of the removal process.

NOTE

- means that this feature varies depending on the model purchased.

Icemaker

1. To make ice, fill the ice tray with water and insert it into its position.

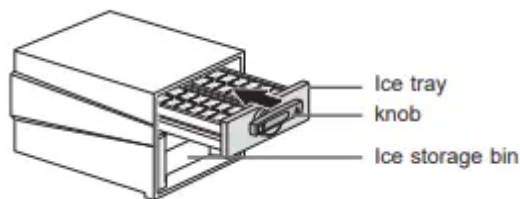

2. To take ice out, rotate the knob of the ice tray clockwise.

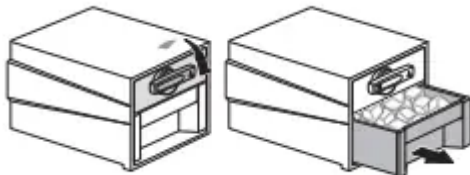

NOTE

- You can remove the icemaker or ice storage bin to create more space inside the freezer if you do not use it.

Using the Folding Shelf (*)

Store taller items, such as a gallon container or bottles, by pushing the front half of the shelf underneath the back half the shelf. Pull the front of the shelf forward to return to a full shelf.

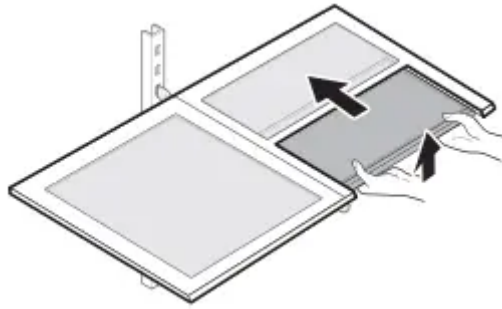

CAUTION

- Glass shelves are heavy. Use special care when removing them.
- Do not clean glass shelves with warm water while they are cold. Shelves may break if exposed to sudden temperature changes or impact.

NOTE

- means that this feature varies depending on the model purchased.

Other Functions

Door Open Alarm

The alarm sounds 3 times in 30 second intervals if the door (fridge compartment, freezer compartment, Door-in-Door) is left open or not completely closed for one minute.

- Contact the LG Electronics customer information centre if the alarm sound continues even after closing the door.

Failure Detection

The appliance can automatically detect problems during the operation.

- If a problem is detected, the appliance may not operate and an error code is displayed even when any button is pressed.
- If an error code is indicated on the display, Do not turn off the power. Immediately contact the LG Electronics customer information center and report the error code. If you turn off the power, the repair technician from the LG Electronics customer information centre may have difficulty finding the problem.

MAINTAINCE

Notes for Cleaning

- When removing a shelf or drawer from inside the appliance, remove all stored foods from the shelf or drawer to prevent injury or damage to the appliance.
 - Otherwise, injury may occur due to the weight of stored foods.

- If cleaning the outside air vents of the appliance by means of vacuuming, then the power cord should be unplugged from the outlet to avoid any static discharge that can damage the electronics or cause an electric shock.
- Detach the shelves and drawers and clean them with water, and then dry them sufficiently, before replacing them.
- Regularly wipe the door gaskets with a wet soft towel.
- Door basket spills and stains should be cleaned as they can compromise storage ability of the basket and could even be damaged.
- After cleaning, check if the power cable is damaged.
- Keep the air vents on the exterior of the appliance clean.
 - Blocked air vents can cause fire or appliance damage.
- Waxing external painted metal surfaces helps provide rust protection. Do not wax plastic parts. Wax painted metal surfaces at least twice a year using appliance wax (or auto paste wax). Apply wax with a clean, soft cloth.
- When cleaning the inside or outside of the appliance, do not wipe it with a rough brush, toothpaste, or flammable materials. Do not use cleaning agents containing flammable substances.
 - This may cause discoloration or damage to the appliance.
 - Flammable substances: alcohol (ethanol, methanol, isopropyl alcohol, isobutyl alcohol, etc.), thinner, bleach, benzene, flammable liquid, abrasive, etc.
- For the appliance exterior, use a clean sponge or soft cloth and a mild detergent in warm water. Do not use abrasive or harsh cleaners. Dry thoroughly with a soft cloth. Do not use contaminated cloths when cleaning the stainless steel doors. Always use a dedicated cloth and wipe in the same direction as the grain. This helps reduce surface staining and tarnishing.
- Never clean the shelves or containers in the dishwasher.
 - The parts may become deformed due to the heat.
- If the appliance is equipped with LED interior lamps, do not remove lamp cover and lamp in any attempt to repair or service it. Please, contact the LG Electronics customer information centre.

Cleaning the Condenser Cover

Use a vacuum cleaner with a brush to clean the condenser cover and vents. Do not remove the panel covering the condenser coil area.

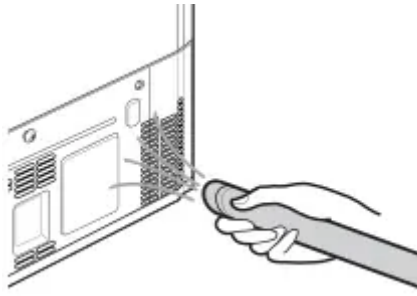

Cleaning The Fridge Shelf

Removing The Fridge Shelf

1. Open the fridge doors completely
2. Tilt the front of the shelf up Slightly and then lift the shelf straight up.

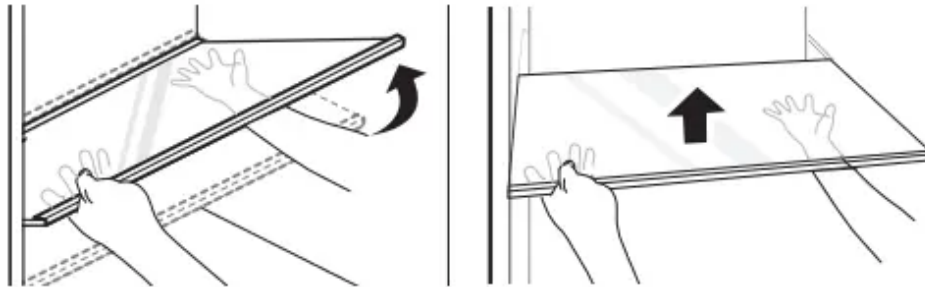

3. Pull the shelf out tilted at an angle

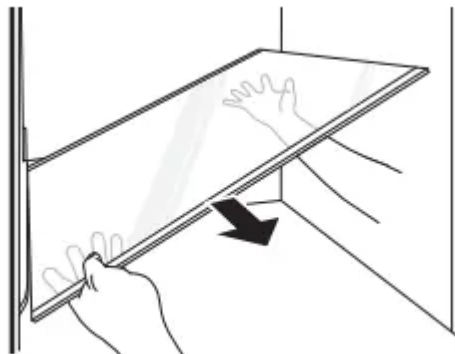

Refitting The Fridge Shelf

Refit the Shelf in the reverse sequence of their removal.

CAUTION

- Make sure that shelves are level from one side to the other. Failure to do so may result in the shelf falling or food spilling.

- Do not clean glass shelves with warm water while they are cold. Shelves may break if exposed to sudden temperature changes or impact.
- Glass shelves are heavy. Use special care when removing them.

Cleaning the Folding Shelf (*)

Removing The Folding Shelf

Tilt up the front of the shelf and lift it straight up. Pull the shelf out tilted at an angle.

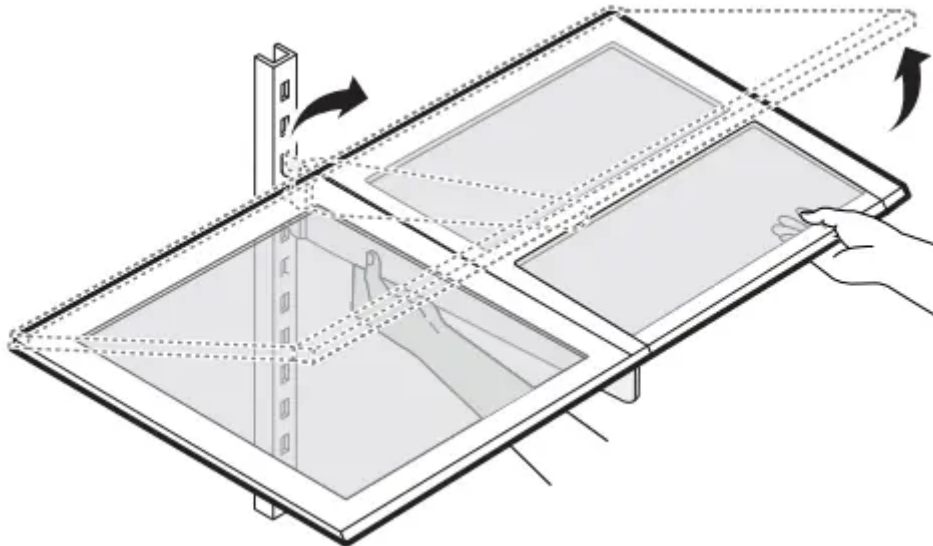

Refitting The Folding Shelf

Tilt the front of the shelf up and guide the rear shelf hooks into the slots at the desired height. Then, lower the front of the shelf so that the hooks drop into the slots.

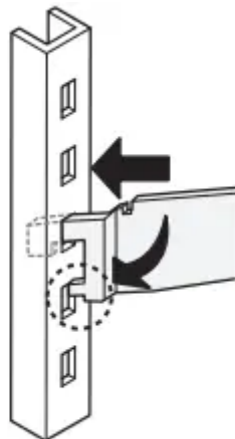

CAUTION

- Make sure that shelves are level from one side to the other. Failure to do so may result in the shelf falling or food spilling.

NOTE

- (*) means that this feature varies depending on the model purchase.

Cleaning the Vegetable Drawer

Removing the Vegetable Drawer

1. Open the doors completely and remove the contents of the Door-in-Door cases and baskets. Remove the Door-in-Door case from the appliance.

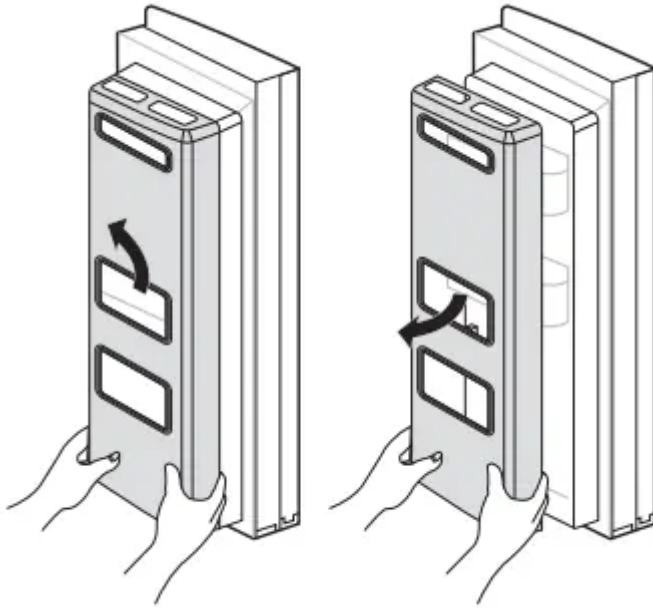

2. Remove the contents of the drawer. Hold the handle of the drawer and gently pull it out completely until it stops. Repeat to remove the second drawer.

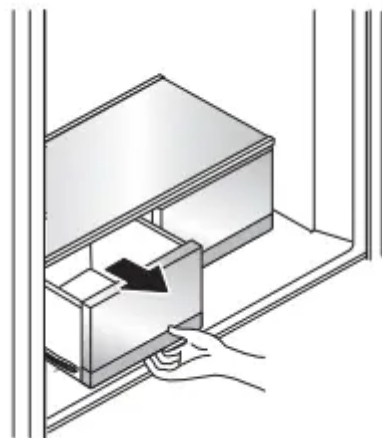

3. Tilt the cover slightly and support it with one hand.

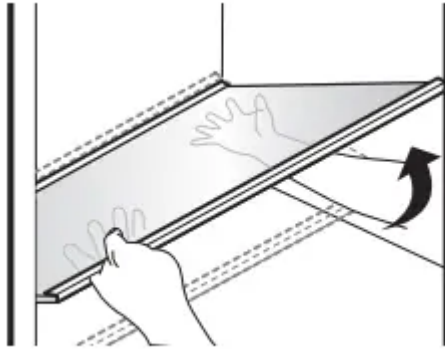

4. Pull the cover out tilted at an angle.

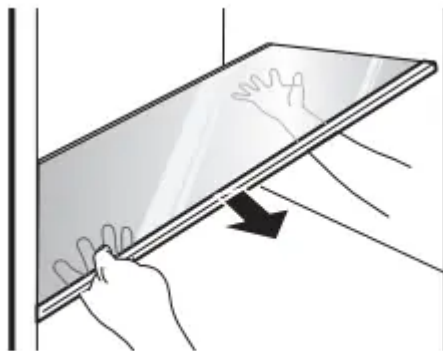

Refitting the Vegetable Drawer

1. Open the fridge doors completely.
2. Insert the bottom of the vegetable drawer into its original position and gently push it back in while lowering it.

Cleaning the Door Basket

Removing the Door Basket

Hold both edges of the basket and remove it by lifting it upward.

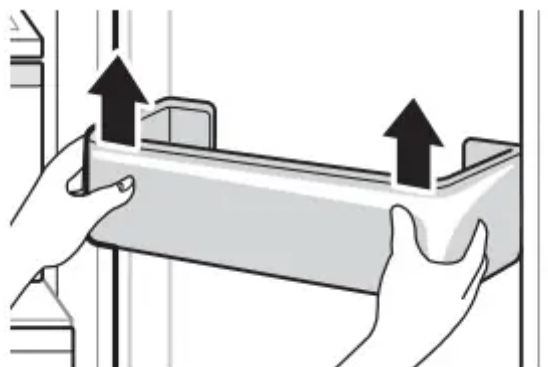

Refitting the Door Basket

Refit the Door Basket in the reverse sequence of their removal.

Cleaning the Freezer Drawer

The sliding freezer drawers allow easy access and convenience of use.

Use the upper compartments to store packaged frozen foods and frequently-used foods.

Use the lower compartment for larger frozen foods and items stored for longer periods.

Removing the Freezer Drawers

1. Open both freezer doors completely. Pull out the freezer trays and drawers to full extension and remove all of the contents.

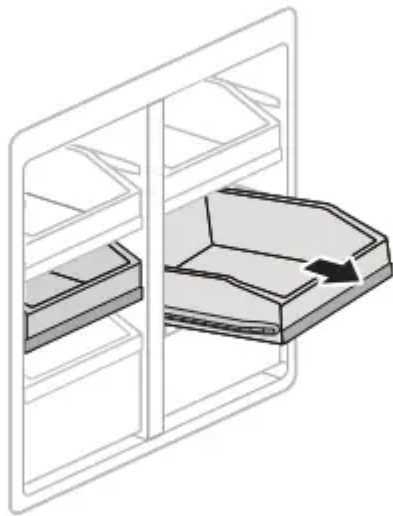

2. With the drawer fully extended, lift up the front and pull the drawer out to remove it.

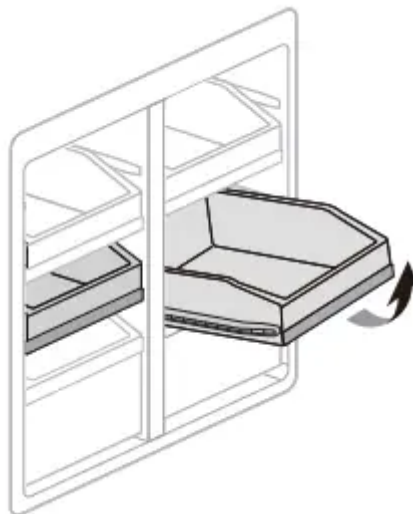

CAUTION

- The drawers are heavy. Always use two hands when removing or assembling the drawers to avoid product damage or personal injury.
- Always open the freezer doors completely before removing or assembling the drawers.

Assembling the Freezer Drawer

1. Open both freezer doors completely. Raise the front of the drawer slightly and insert the rollers on the drawer's sides into the guides in the freezer compartment.

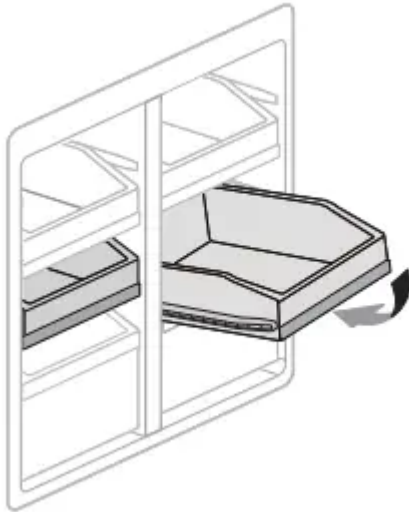

2. Gently push the drawer in while lowering it into place.

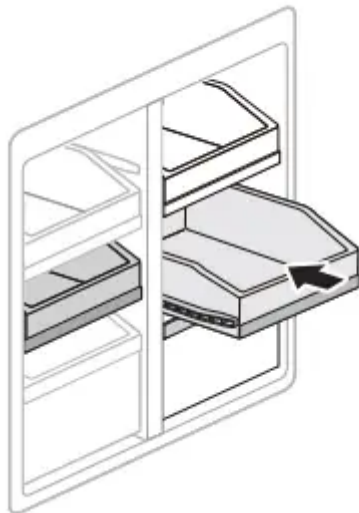

CAUTION

- The drawers are heavy. Always use two hands when removing or assembling the drawers to avoid product damage or personal injury.
- Always open the freezer doors completely before removing or assembling the drawers.

Replacing the Pure N Fresh Filter

To maintain the performance of the Pure N Fresh filter, if a message indicating the filter replacement is displayed, replace the filter as soon as possible.

1. If Replace Filter icon lights on the control panel, replace the Pure N Fresh filter.



2. Hold and remove the Pure N Fresh filter cover by rotating it counterclockwise until the hooks(1) are separated completely.

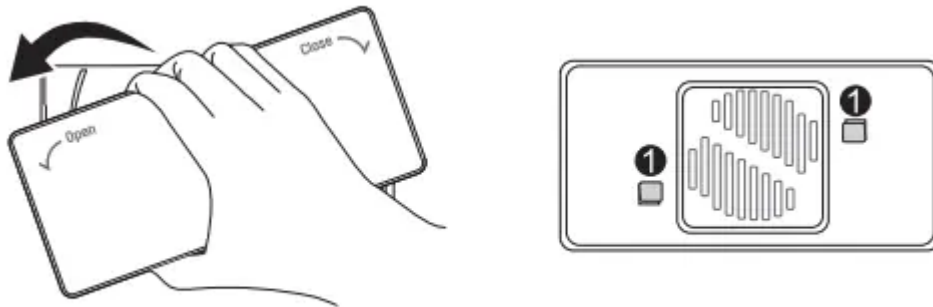

3. Remove the filter inside the Pure N Fresh filter cover and replace it with a new filter.

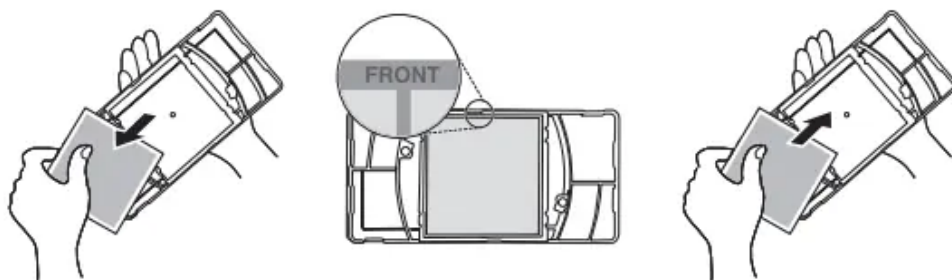

4. Hold and refit the air filter cover by rotating it clockwise until the hooks are engaged completely.

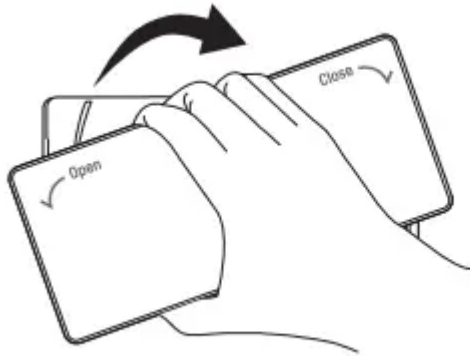

5. To reset the filter replacement period, press the **Pure N Fresh** button on the control panel for more than 3 seconds. The **Replace Filter** icon on the control panel will turn off. It will operate after replacing the filter.



NOTE

- Do not insert your finger or other foreign objects inside or its mounting. Doing so may result in injuries or malfunctions.
- If the replacement period has passed, the bacteria and odor removal performance may deteriorate.
- Please note that if you wash the filter with water, the filter performance may also deteriorate.
- Caution should be taken not to change the direction of the filter to be inserted into the filter cover.
- When setting the appliance to On or Power mode after replacing the filter, check if the LED lamp near the filter is on.
- The filter can be purchased from an LG Electronics customer information centre.

TROUBLESHOOTING



Symptoms	Reason	Solution
<p>There is no refrigeration or freezing.</p>	<p>Is there a power interruption?</p> <p>If the power plug unplugged from the outlet?</p>	<ul style="list-style-type: none"> • Check the power of other appliances. • Plug the power plug in the outlet properly.
<p>There is poor refrigeration or freezing.</p>	<p>Is the fridge or freezer temperature set to its warmest setting?</p> <p>Is the appliance in direct sunlight, or is it near a heat generating object such as cooking oven or heater?</p> <p>Did you store hot food without cooling it first?</p> <p>Did you put in too much food?</p> <p>Are the appliance doors completely closed?</p> <p>Is there enough space around the appliance?</p>	<ul style="list-style-type: none"> • Set the fridge or freezer temperature to Mid setting or colder. • Check the installation area and reinstall it away from heat generating objects. • Cool the hot food first before putting it in the fridge or freezer compartment. • Maintain an appropriate space between food. • Completely close the door and make sure that stored food is not obstructing in the door. • Adjust the installation position to make enough space around the appliance.
<p>The appliance contains a bad smell.</p>	<p>Is the fridge or freezer temperature set to 'Warm'?</p> <p>Did you put in food with a strong smell?</p> <p>Vegetables or fruit may have spoiled in the drawer?</p>	<ul style="list-style-type: none"> • Set the fridge or freezer temperature to Mid setting or colder. • Store foods with strong smells in a sealed containers. • Throw away rotten vegetables and clean the vegetable drawer. Do not store vegetables too long in the vegetable drawer
<p>The inside lamp in the appliance does not turn on.</p>	<p>Does the inside lamp in the appliance turn off?</p>	<p>It is not possible for customers to replace the inside lamp in the appliance as they are not serviceable. If the inside lamp does not turn</p>



		on, please contact the LG Electronics customer information centre.
The appliance door is not closed tightly.	<p>Is the appliance leaning forward?</p> <p>Were the shelves properly assembled?</p> <p>Did you close the door with excessive force?</p>	<ul style="list-style-type: none"> • Adjust the front feet to raise the front side slightly. • Refit the shelves if needed. • If you apply too much force or speed when closing the door, it may remain briefly open before closing. Make sure that you do not slam the door closed. Close without force.



Symptoms	Reason	Solution
<p>Frost or condensation has formed inside or outside the appliance.</p>	<p>Did you open and close the appliance door frequently or is the appliance door improperly closed?</p> <p>Is the installation environment humid?</p>	<ul style="list-style-type: none"> • Frost or condensation can form if the outside air penetrates inside the appliance. • Condensation can appear on the exterior of the appliance if the installation area is too humid or on a humid day such as a rainy day. Wipe off any moisture with a dry cloth.
<p>The appliance is noisy and generates abnormal sounds.</p>	<p>Is the appliance installed on a weak floor or improperly leveled?</p> <p>Does the rear of the appliance touch the wall?</p> <p>Are objects scattered behind the appliance?</p> <p>Is there an object on top of the appliance?</p>	<ul style="list-style-type: none"> • Install the appliance on a firm and level floor. • Adjust the installation position to allow enough clearance around the appliance. • Remove the scattered objects from behind the appliance. • Remove the object on top of the appliance.
<p>The side or front of the appliance is warm.</p>	<p>There are anti condensation pipes fitted to these areas of the appliance to reduce condensation forming from around the door area.</p>	<p>The heat releasing pipe to prevent condensation is installed on the front and side of the appliance. You may feel it particularly hot right after the appliance is installed or during the summer. You can be assured that this is not a problem and is quite normal.</p>
<p>There is water inside or outside of the appliance.</p>	<p>Is there water leakage around the appliance?</p> <p>Is there water on the bottom of the appliance?</p>	<ul style="list-style-type: none"> • Check if the water has leaked from a sink or another place. • Check if the water is from the thawed frozen food or a broken or dropped container.



Symptoms	Reason	Solution
<p>The automatic icemaker does not produce ice or produces a small amount of ice.</p>	<p>Did you install the appliance recently?</p> <p>Did you connect the water supply pipe to the appliance and open the supply valve?</p> <p>Is the water supply hose bent?</p> <p>Have you dispensed a large amount of ice recently?</p> <p>Did you set the ice maker switch or the automatic icemaker button on the control panel to ON?</p> <p>Is the temperature of the freezer compartment set too high?</p> <p>Have you been opening the appliance door frequently?</p> <p>Is the appliance door completely closed?</p>	<ul style="list-style-type: none"> • The ice maker produces ice normally when approximately 48 hours have passed after the appliance is installed. • Connect the water supply pipe to the appliance and open the supply valve completely. • If the water supply hose is bent, the water flow could be compromised. • It takes approximately 24 hours to produce more ice in the automatic icemaker. Please wait. • Press I on the automatic icemaker switch or set ON for the automatic icemaker button on the control panel. (For more details on how to use, visit LG electronics website or use your smart device.) • If the set temperature is too warm, ice will be produced slowly or not at all. Set the Freezer temperature to -18 °C for normal operation of the automatic icemaker. • If you open the appliance door frequently, cold air will escape, lowering the speed of ice production. Do not open and close the appliance door frequently. • If the appliance door is not completely closed, the temperature of the freezer compartment will increase, slowing down the ice production speed. Close the appliance door completely.
<p>Ice is not dispensed.</p>	<p>Is there ice in the ice bin?</p>	<ul style="list-style-type: none"> • Check whether there is ice in the ice bin.



Is the ice clumped in the ice bin?

- Separate the ice bin and shake it. Discard the remaining clumped ice after shaking the ice bin.

Symptoms	Reason	Solution
<p>Ice is not dispensed.</p>	<p>Unable to hear the sound of ice coming out?</p> <p>Is the ice path blocked? (You can check the ice passage by separating the ice bin.)</p>	<ul style="list-style-type: none"> • In the control panel, select the modes for cubed ice and crushed ice alternately to dispense the ice. • Ice may not be dispensed properly if the ice passage is blocked. Check the ice and clean the ice path regularly.
<p>Water does not come out.</p>	<p>Are you using unfiltered water?</p> <p>The water dispenser tank may be empty? (For non plumbed models only)</p> <p>Water does not come out when the water tube is filled with air. (For non plumbed models only)</p> <p>The supply valve may be turned off? (For plumbed models only)</p> <p>Is the water supply valve closed? (For plumbed models only)</p>	<ul style="list-style-type: none"> • Unfiltered water can contain a large amount of various heavy metals or foreign substances, so the filter may be clogged in the early stage regardless of the life of the filter. • Fill the water dispenser tank. • Remove the water dispenser tank by pulling it out while holding the handle. Fill the water dispenser tank with water and refit it on the fridge shelf. • Open the water supply valve. • Open the water supply valve.
<p>Water tastes strange.</p>	<p>Is the taste of water different when comparing it with the taste of water from the previous water purifier?</p>	<ul style="list-style-type: none"> • Has the purified water or cold water not been used for an extended period of time? • If an expired filter is used, the purification performance may decline. It is recommended to replace the filter according to the filter replacement period.



Has it been a long time since you installed and replaced the filter?

Have you flushed out the filter properly in the initial stage after installing it?

Has the purified water or cold water not been used for an extended period of time?

- When you install or replace the filter for the first time, you need to remove air and activated carbon residue from inside the filter. Use the appliance after dispensing and discharging approximately 5 litres of purified water from the dispenser by pressing the water dispensing lever. (Activated carbon is harmless to humans.)
- The taste of old water may change due to bacterial growth. Use the product after dispensing and discharging approximately 5 litres (approximately three minutes) from the water dispenser.

Symptoms	Reason	Solution
Clicking noises	The defrost control will click when the automatic defrost cycle begins and ends. The thermostat control (or appliance control on some models) will also click when cycling on and off.	Normal Operation
Rattling noises	Rattling noises may come from the flow of appliance, the water line on the back of the unit (for plumbed models only), or items stored on top of or around the appliance. Appliance is not resting evenly on the floor. Appliance with linear compressor was moved while operating.	Normal Operation Floor is weak or uneven or leveling legs need to be adjusted. See the Door Alignment section. Normal operation. If the compressor does not stop rattling after three minutes, turn the power to the appliance off and then on again.
Whooshing noises	Evaporator fan motor is circulating air through the fridge and freezer compartments. Air is being forced over the condenser by the condenser fan.	Normal Operation Normal Operation
Gurgling noises	Appliance flowing through the cooling system	Normal Operation
Popping noises	Contraction and expansion of the inside walls due to changes in temperature.	Normal Operation
Vibrating	If the side or back of the appliance is touching a cabinet or wall, some of the normal vibrations may make an audible sound.	To eliminate the noise, make sure that the sides and back do not make any contact with any wall or cabinet.

Symptoms	Reason	Solution
<p>Your home appliance and smartphone is not connected to the Wi-Fi network.</p>	<p>The password for the Wi-Fi that you are trying to connect to is incorrect.</p> <p>Mobile data for your smartphone is turned on.</p> <p>The wireless network name (SSID) is set incorrectly</p> <p>The router frequency is not 2.4 GHz.</p> <p>The distance between the appliance and the router is too far.</p>	<p>Find the Wi-Fi network connected to your smartphone and remove it, then register your appliance on LG SmartThinQ.</p> <p>Turn off the Mobile data of your smartphone and register the appliance using the Wi-Fi network.</p> <p>The wireless network name (SSID) should be a combination of English letters and numbers. (Do not use special characters.)</p> <p>Only a 2.4 GHz router frequency is supported. Set the wireless router to 2.4 GHz and connect the appliance to the wireless router. To check the router frequency, check with your Internet service provider or the router manufacturer.</p> <p>If the distance between the appliance and the router is too far, the signal may be weak and the connection may not be configured correctly. Move the location of the router so that it is closer to the appliance.</p>

Warning

This content is compiled from multiple sources and is provided for reference purposes only. It may not be complete or fully applicable to all situations. If you are unable to resolve your issue, please contact the product manufacturer or an authorized service provider for official support.

