

## INTRODUCTION

### Before you start

- Make sure the installer has completed the 'Final checklist' in the Installation instructions.
- Read this guide, taking special note of the 'Safety and warnings' section.
- Remove all packaging and dispose of it responsibly. Recycle items that you can.
- Fit the side racks and catalytic panels (see 'Fitting the side racks and catalytic panels').
- We recommend you then condition the oven, using the instructions following.

Note: Not all accessories are provided with all models. To purchase other accessories, contact your nearest Fisher & Paykel Authorised Service Centre, Customer Care or visit our local website listed on the back cover

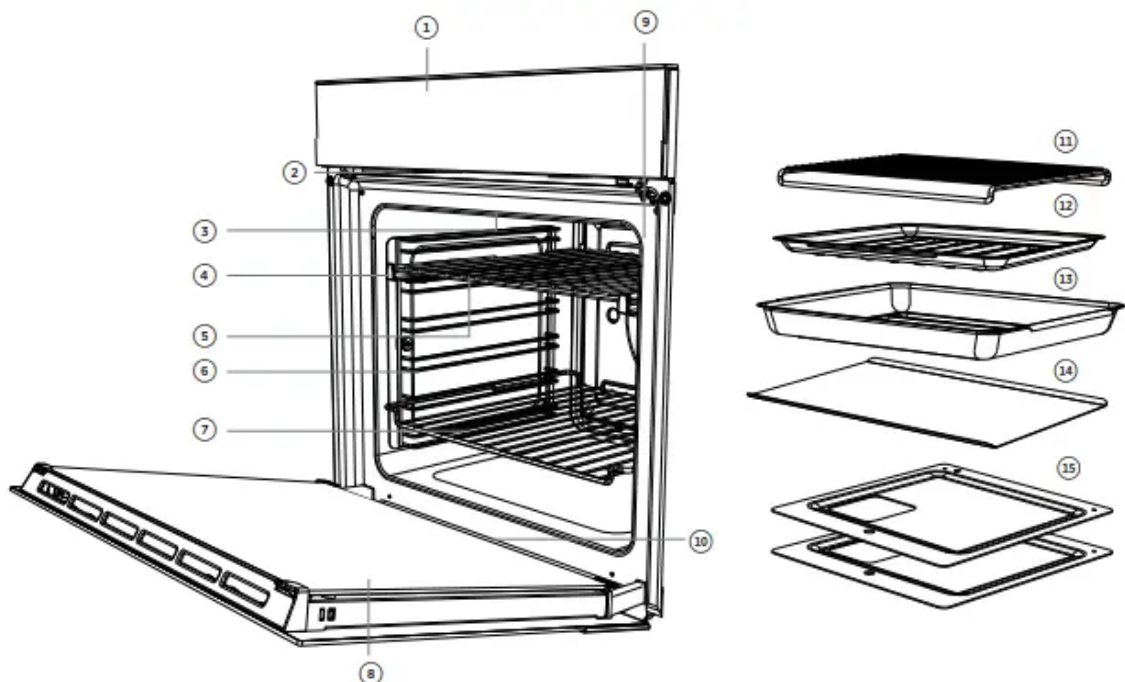

1. Control panel
2. Oven vent louvres
3. Oven light
4. Sliding shelf support
5. Wire shelf
6. Side rack
7. Step down oven wire shelf
8. Oven door and handle

9. Oven seal !0 Drip channel

Accessories:

11. Grill rack

12. Grid

13. Roast Dish

14. Flat baking tray

15. Catalytic panels (suitable for some models only).

## FIRST USE

### Fitting the side racks and catalytic panels (some models only, purchased separately)

You will find your side racks and catalytic panels (some models only, may be purchased separately) in the accessory box supplied with your oven.

#### Fit the catalytic panel to the side rack

1. Ensure the panels are placed the correct way around: in models with side lights: the cutout fits over the light and the hole for the fixing screw goes to the front of the oven. in models with a ceiling light: the hole for the fixing screw goes to the front of the oven. (Note: panels should sit flush against the oven wall).
2. Fit the rear prongs of the side rack through the holes in the catalytic panel.

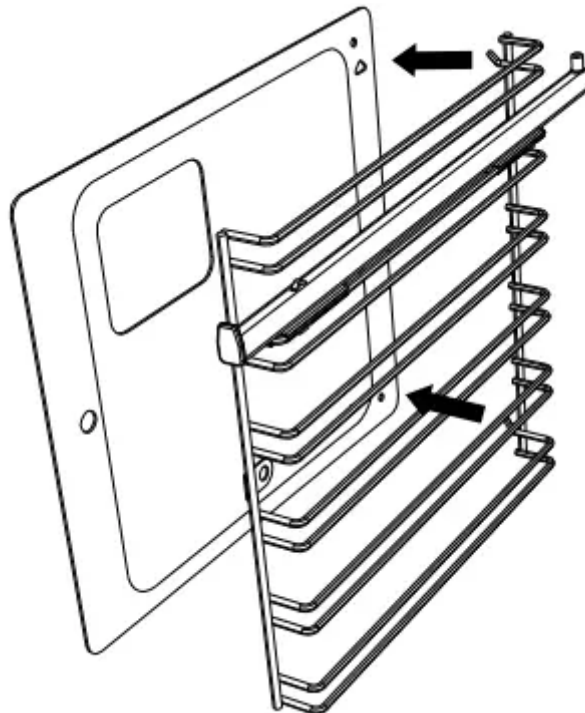

#### Fit the side racks

1. Slide the rear prongs of the side rack into the holes at the rear of the oven

2. Fit the side rack front tab (and catalytic panel if fitted) over the fixing screw.
3. Replace the fixing nut. You may use a coin to tighten the nut.

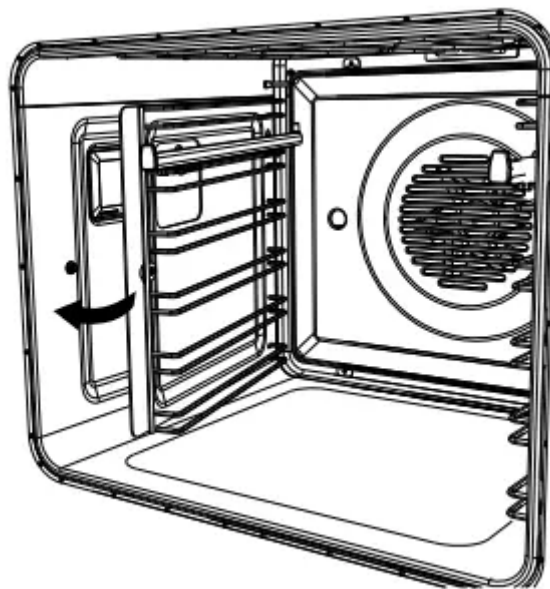
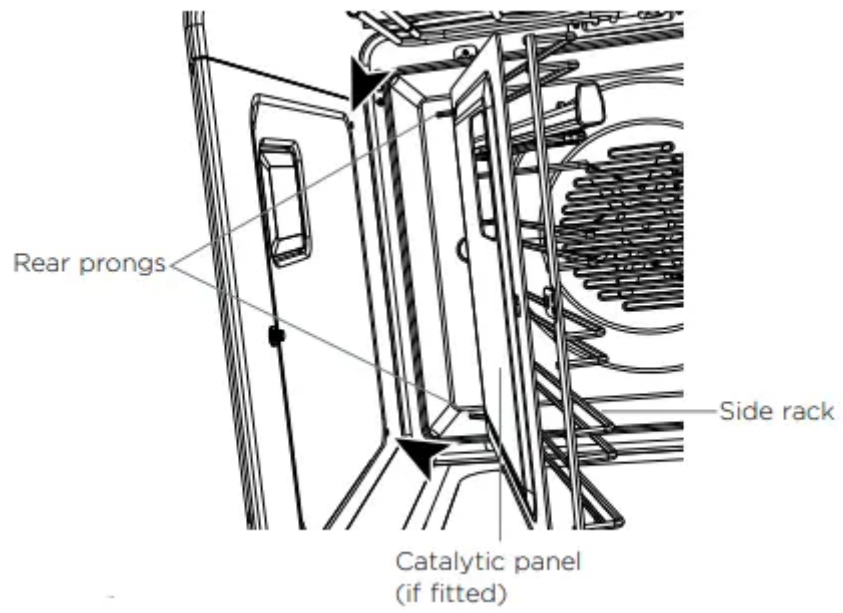

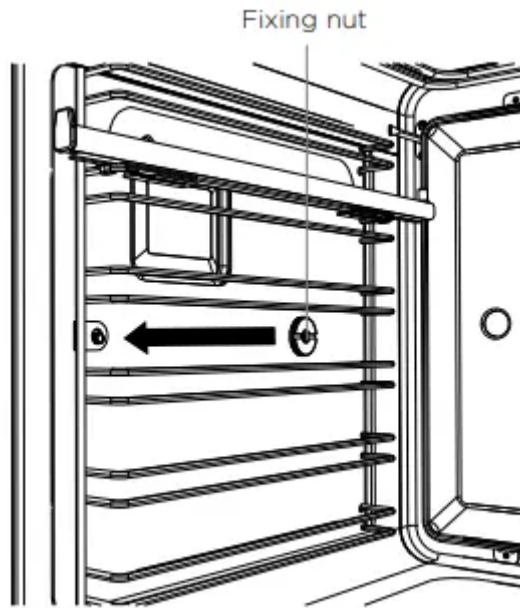

## The Control Panel

Illustrative purposes only - oven functions may vary.

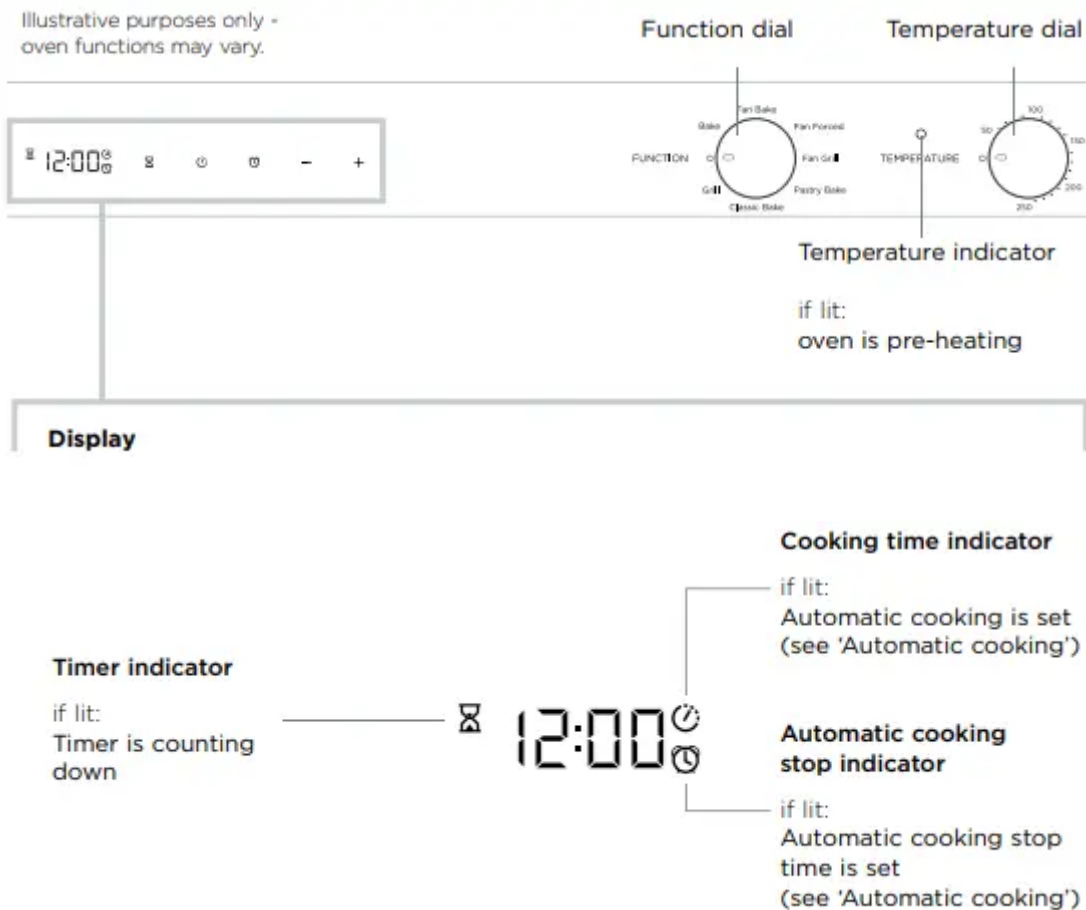

## Touch controls

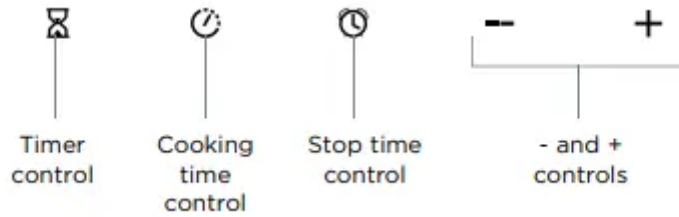

### Using the touch controls

- Use the ball of your finger, not its tip. The controls respond to touch, so you don't need to apply any pressure.

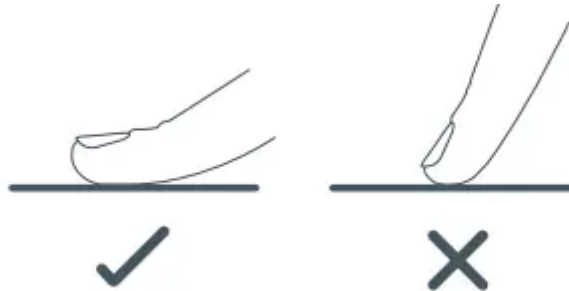

### Setting the Clock

IMPORTANT: Before using your oven for the first time and after a power cut, the clock must be set. The oven will not function if the clock is not set.





1. When the power to the oven is turned on or restored after a power failure, 0:00 will flash in the display

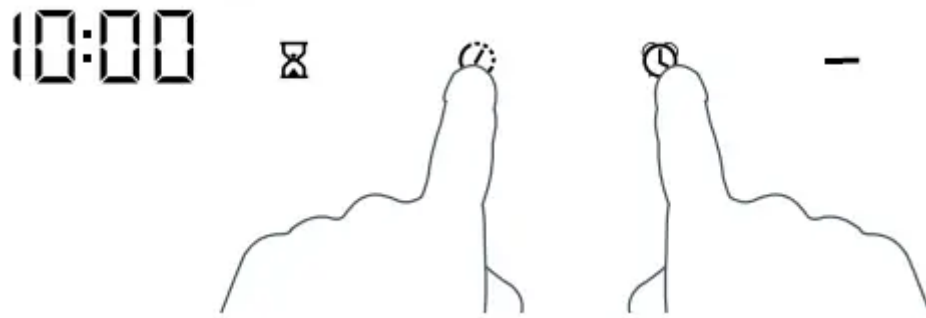

2. Touch the - or + controls to set the time.





3. Touch the cooking time  and stop time  controls together for 2 seconds to accept the time.

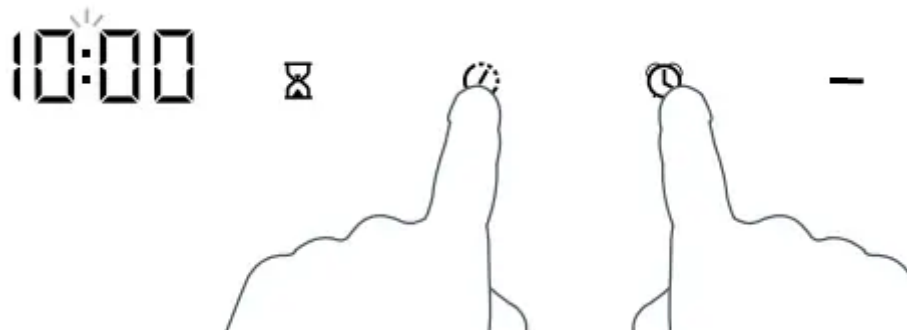

- the display will stop flashing
- the oven will beep to confirm the time is set.



### To Change the Time

4. Touch the cooking time  and stop time  controls together for 2 seconds. The centre dot will flash.

5. Touch the - and + controls to set the new time.

6. Touch the cooking time  and stop time  controls together again for 2 seconds to accept the new time.

- the centre dot will stop flashing
- the oven will beep to confirm the new time is set.

### Condition the oven

It is important to condition your oven before using it for cooking and baking. Conditioning will burn off any manufacturing residues and ensure that you get the best results right from the start.

1. Make sure you have removed all packaging (including the yellow packing retainers). Make sure the side racks and catalytic panels (some models only) are fitted.
2. Make sure you have set the clock.

3. Make sure all the shelves are fitted.

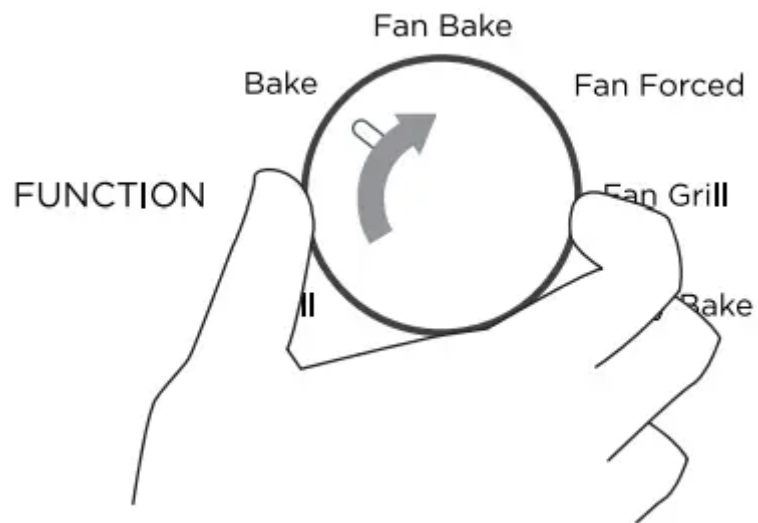

4. Select the Bake function. The oven will come on.

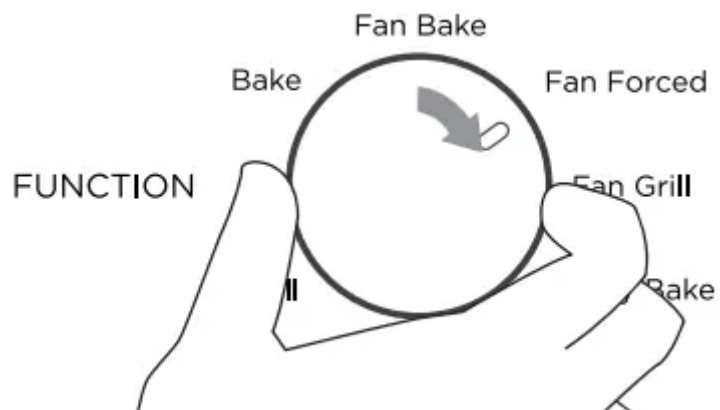
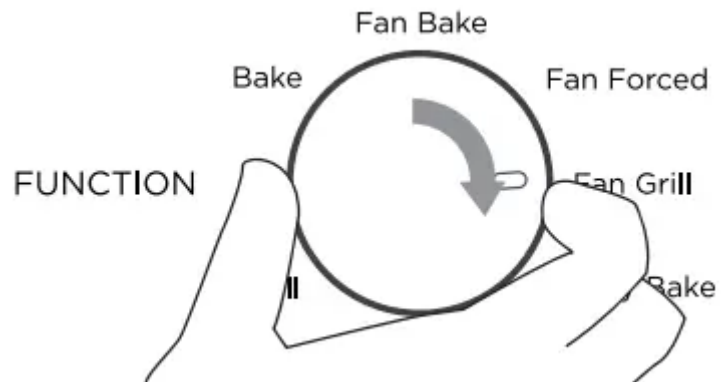

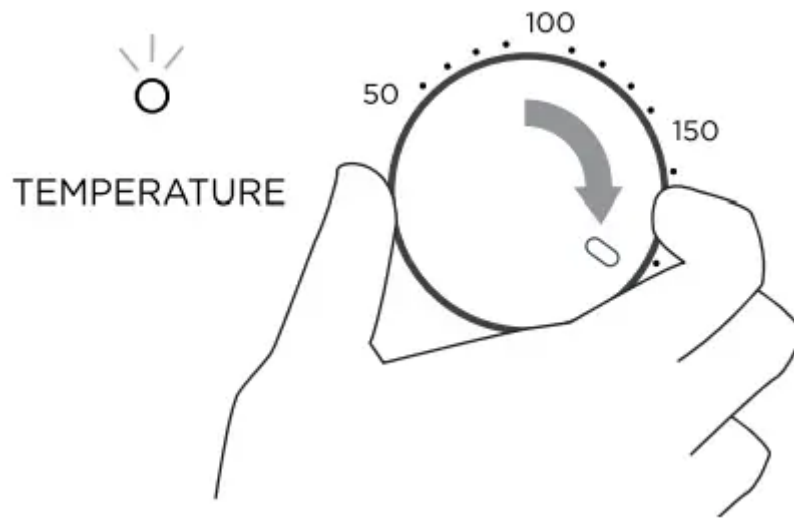

5. Set the temperature to 200 oC for 30 minutes.

- While the oven is heating up, the temperature indicator light will glow.
- When the oven has reached set temperature, the temperature indicator light will go out. Note: if the clock has not been set, the cooling fans will come on, but the oven light will not come on and the oven will not heat up.

6. After 30 minutes is up, select the Fan Grill function, and heat for 20 minutes.

7. After 20 minutes is up, select the Fan Forced Function. After 20 minutes, switch the oven off.

- There will be a distinctive smell and a small amount of smoke during the conditioning process as manufacturing residue is burnt off. This is normal, but make sure the kitchen is well ventilated while the oven is conditioning.
- Once cooled, wipe out the oven with a damp cloth and mild detergent, and dry thoroughly.

## USING THE TIMER

- You can use the timer at any time, even if you are not using the oven.
- The time counts down in minutes (hours:min) until the last 5 minutes of cooking, when it will countdown in seconds (min:sec).
- You can set the timer for up to 4 hours.



**IMPORTANT :** The timer does NOT turn the oven off.

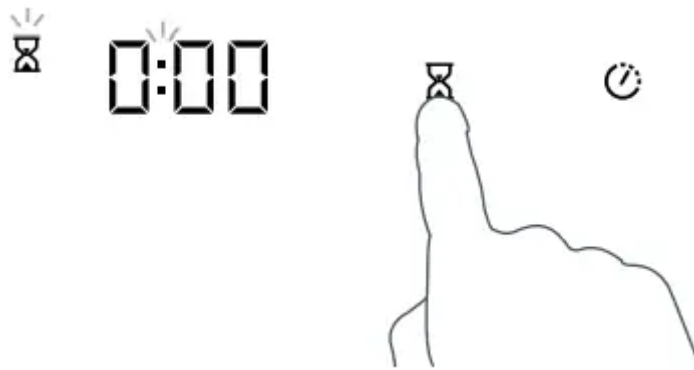

1. Check the display shows the correct time of day





2. Touch the timer  control.

- the display will show 
- the timer indicator  and dot will flash.



3. Touch the - and + controls to set the time.

4. Touch the timer  control to set the timer or wait 5 seconds and the display will show the time of day and the timer indicator .

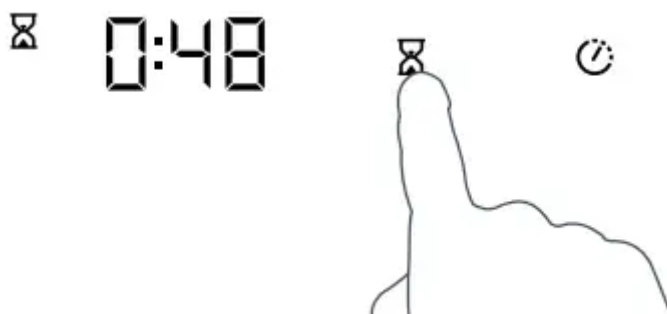

5. To check the time remaining time: Touch the timer  control.

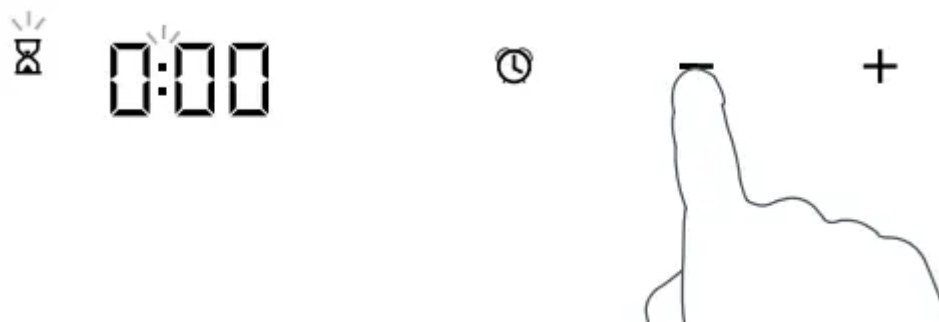

- During the last 5 minutes of the countdown the display will show the time remaining.



### To cancel the timer

1. Touch the timer  control to show the remaining time.

2. **Either:**

Touch the - control and scroll the time down to  or Touch and hold the - and + controls together until the display shows 

3. the timer indicator and display will flash for a few seconds and then return to the time of day

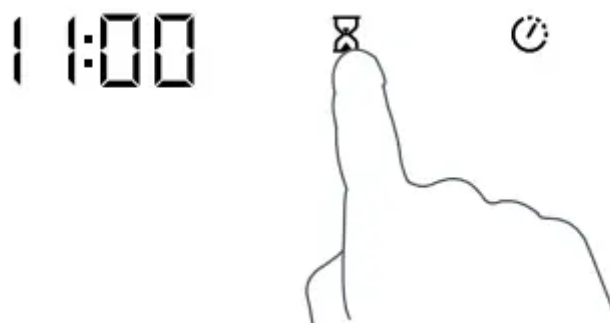

### At the end of the countdown

- The timer will 'beep' every 7 seconds.
- The timer indicator will flash.
- The display will show 
- To cancel the beeping and return to the time of day, touch any control.

## COOKING GUIDE

### General guidelines

This oven has been designed to utilise its four elements and rear fan in differing combinations to provide you with enhanced performance and a wide range of functions, allowing you to cook all types of food to perfection.

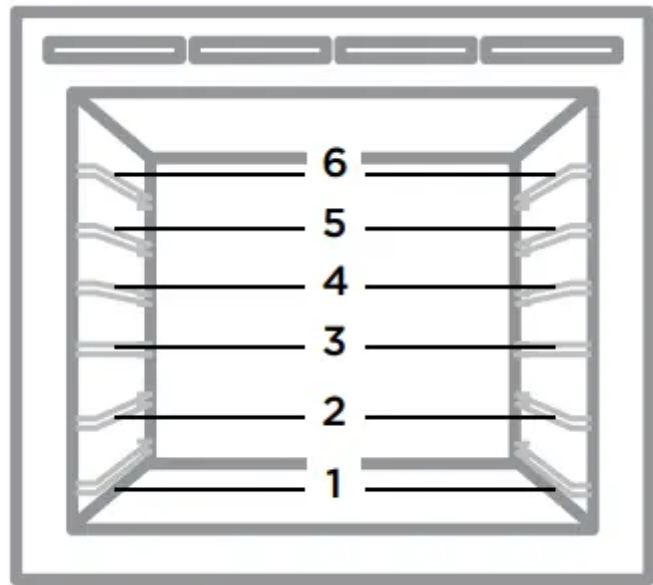
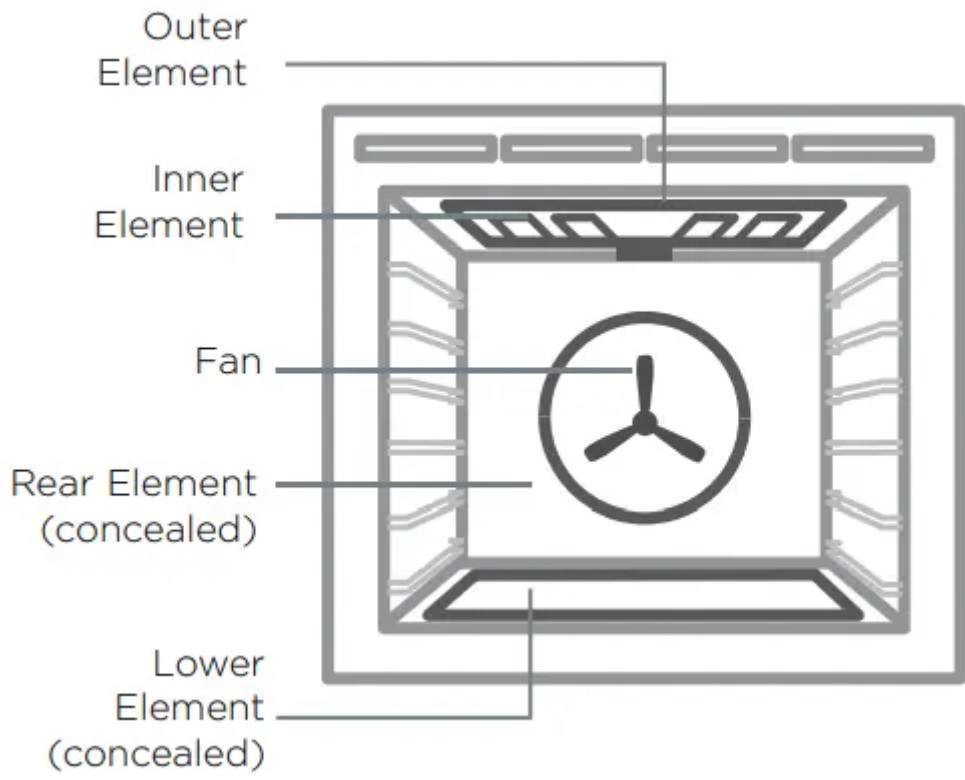

Shelf positions - Full size ovens



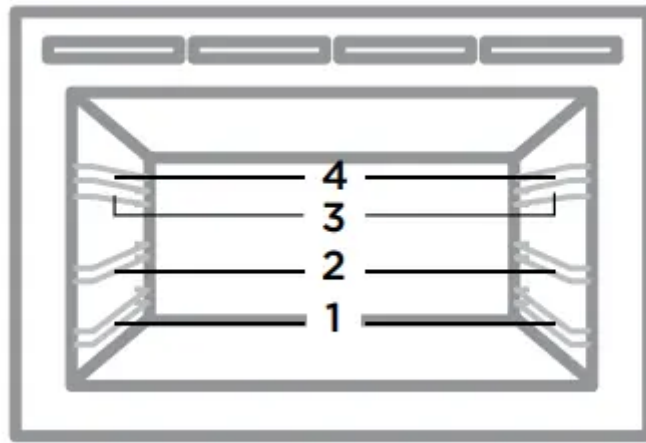

Shelf positions - Compact ovens

## BAKING

- For best results when baking, always pre heat your oven. The temperature indicator will go out when the pre-set temperature is reached.
- While the oven is heating the grill element may be on.
- Do not open the door until at least 3/4 of the way through cooking.
- Make sure cake pans do not touch each other or the sides of the oven.
- When baking double the recipe (especially cookies) you may need to increase the time by a couple of minutes.
- Your cookware will influence baking times. Dark pans absorb the heat more quickly than reflective pans; glass cookware may require a lower temperature.
- Multi-shelf baking may also require a slight increase in cooking time.
- Always leave a space between shelves when multi-shelf cooking to allow the air to circulate

### Shelf Position Guide

Place your baking on a shelf that will have the top of your pan near the centre of the oven cavity

## ROASTING

- Use Fan Grill to roast whole chicken.
- For other meats use Bake for a succulent juicy flavoursome roast. If your model does not have a Bake function, use Fan Forced.
- Boneless, rolled or stuffed roasts take longer than roasts containing bones.
- Poultry should be well cooked with the juices running clear and an internal temperature of 75°C.
- For crispy crackling first sear the Pork at a high temperature, then lower the temperature to complete the cooking.

- If multi-shelf cooking (eg if roasting meat on one shelf and vegetables on another) use Fan Forced.
- Cook larger cuts of meat for longer at a lower temperature. The meat will cook more evenly.
- Always roast meat fat side up. That way, basting may not be required. Always rest the meat for at least 10 minutes after roasting to allow the juices to settle. Remember the meat will continue to cook for a few minutes after removing it from the oven.

### **Shelf Position Guide**

Place the meat on a shelf so that the meat is in the centre of the oven or lower.

## **GRILLING**

- This is a healthier alternative to frying.
- Always grill with the oven door completely shut.
- If you use glass or ceramic pans, be sure they can withstand the high temperatures of the grill.
- To avoid piercing the meat and letting juices escape, use tongs or a spatula to turn the meat halfway through cooking.
- Brush meat with a little oil to help keep the meat moist during cooking. Alternatively marinate the meat before grilling (but be aware that some marinades may burn easily).
- Where possible grill cuts of meat of a similar thickness at the same time. This will ensure even cooking.
- Always keep a close watch on your food while grilling to avoid charring or burning

### **Shelf Position Guide**

- For thinner cuts of meat, toasting or browning foods, use a higher shelf position.
- Thicker cuts of meats should be grilled on lower shelves or at a lower grill setting to ensure even cooking.

## **REHEATING**

- Use Bake or Fan Bake to reheat food.
- Always reheat food to piping hot. This reduces the risk of contamination by harmful bacteria.
- Never reheat a food more than once.
- Note: any condensation that forms during the cooking process will collect in the drip channel, below the door. This may be mopped up using a sponge once the oven has cooled.

# OVEN FUNCTIONS

## IMPORTANT!

- Depending on your model, you may only have some of these functions.
- Use all the functions with the oven door closed.

## Bake (some models only)

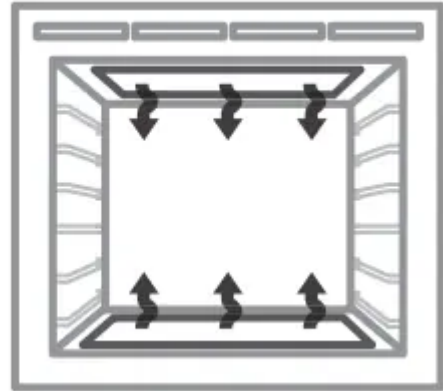

### upper outer and lower elements

- Heat comes from both the upper and lower elements. The fan is not used in this function.
- Ideal for cakes and foods that require baking for a long time or at low temperatures.
- This function is not suitable for multi-shelf cooking.

*Ideal for moist foods that take a longer time to cook eg rich fruit cake.*

## Fan Bake

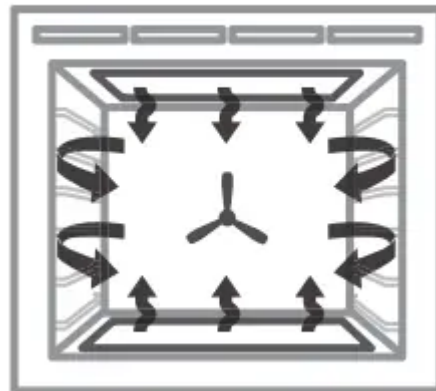

### fan plus upper outer and lower elements

- The oven fan circulates hot air from the top outer and the lower elements and distributes it around the oven cavity.
- Food cooked tends to brown more quickly than foods cooked on the traditional Bake function.
- You may need to decrease the time from that recommended in traditional recipes.

- Use Fan Bake at a low temperature eg 50°C for drying fruit, vegetables and herbs.

*Ideal for single shelf baking that takes less than an hour to cook – foods such as muffins, scones and cupcakes or things like enchiladas.*

## Fan Forced (some models only)

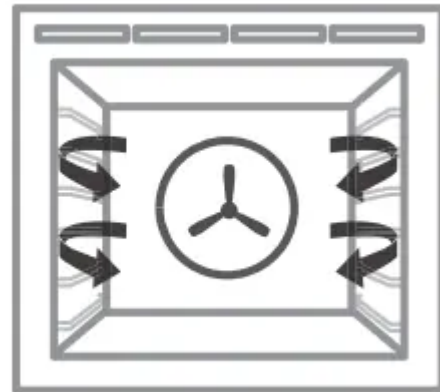

### fan and rear element

- By using the central rear heating element and fan, hot air is blown into the cavity, providing a consistent temperature at all levels, making it perfect for multi-shelf cooking.
- Trays of cookies cooked on different shelves are crisp on the outside and chewy in the middle.
- Meat and poultry are deliciously browned and sizzling while remaining juicy and tender.
- Casseroles are cooked to perfection and reheating is quick and efficient.
- When multi-shelf cooking it is important to leave a gap between trays (eg use shelves 3 & 5) to allow the air to move freely. This enables the browning of foods on the lower tray.
- If converting a recipe from Bake to Fan Forced, we recommend that you decrease the bake time or decrease the temperature by approximately 20°C.
- For items with longer bake times (eg over an hour) it may be necessary to decrease both time and temperature.

*Ideal for multi-shelf cooking biscuits, cookies, scones, muffins and cupcakes.*

## Fan Grill

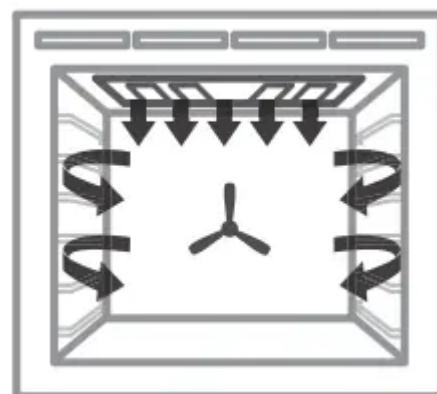

### fan plus upper inner and outer elements

- This function uses the intense heat from the upper elements for top browning and the fan to ensure even cooking of foods.
- Meat, poultry and vegetables cook beautifully; food is crisp and brown on the outside while the inside remains moist and tender.

*Ideal for whole chicken, tenderloin of beef or grilling your favourite chicken, fish and steak.*

### Pastry/Pizza Bake (some models only)

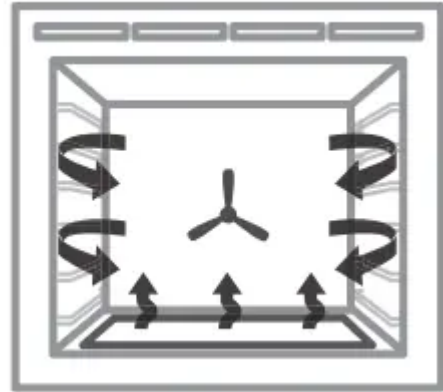

### fan plus lower element

- The fan circulates heat from the lower element throughout the oven.
- Excellent for cooking pizza as it crisps the base beautifully without overcooking the topping.
- For best results, pre-heat pizza stone for at least 1 hour and bake on oven shelf position 1 or 2.

*Ideal for foods such as sweet and savoury pastry foods and delicate foods that require some top browning eg frittata, quiche.*

### Classic Bake (some models only)

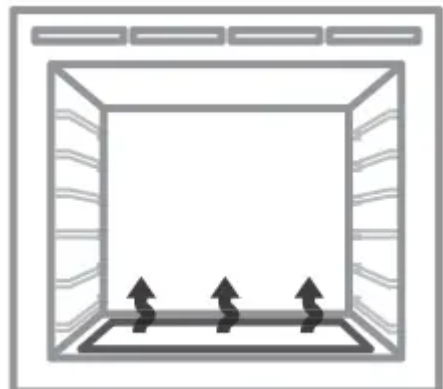

### lower element only

- Heat comes from the lower element only, the fan is not used.

- This is the traditional baking function, suitable for recipes that were developed in older ovens.
- Bake on only one shelf at a time.
- The oven will be hotter at the top.

*Ideal for foods that require delicate baking and have a pastry base, like custard tarts, pies, quiches and cheesecake or anything that does not require direct heat and browning on the top.*

## **Grill**

### **Maxi Grill**

**(some models only)**

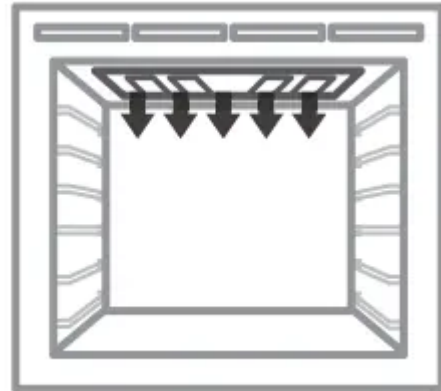

#### **upper inner and outer elements**

- This function delivers intense radiant heat from the top element(s). On some models there is the choice of Grill (inner top element only) and Maxi Grill (inner and outer top elements). You can set the intensity of the heat by altering the temperature setting.
- Preheating is not essential although some people prefer to allow the element to heat for a few minutes before they place food under the grill.
- The most suitable function for 'finishing off' many meals, for example browning the top of potato gratin and frittata.
- On models with both Grill and Maxi Grill functions, use Grill for grilling smaller dishes. Ensure you centre the dish under the inner grill element.

***Ideal for toasting bread or for top browning to 'finish off dishes'***

## **COOKING CHARTS**

- Shelf positions are counted from the base up. (1 is the lowest, 6 (full size ovens) or 4 (compact ovens) is the highest). Position shelves before you turn the oven on.
- For best results always preheat the oven to the required temperature.
- The grill element may come on while the oven is heating up.
- The temperature indicator light will go out when the oven has reached the selected temperature.

- Note: oven accessories may temporarily deform slightly when they become hot. This is normal and does not affect their function.

<b>BAKING</b>		
<b>FOOD</b>		<b>SHELVES</b>
<b>Biscuits</b>	Plain	Single
		Multi*
	Chewy choc chip	Single
		Multi*
	Oatmeal	Single
<b>Slices / Squares</b>		Single
<b>Cakes</b>	Vanilla	Single
	Butter / Chocolate	Single
	Light fruit	Single
	Rich fruit	Single
	Sponge (single large)	Single
	Sponge (two small pans)	Single
<b>Shortbread</b>		Single
<b>Muffins / Cupcakes</b>		Single
		Multi*
<b>Scones</b>		Single
		Multi*
<b>Meringues</b>		Single
<b>Bread Rolls</b>		Single
<b>Pastry</b>	Phyllo	Single
	Flaky/Puff	Single
	Choux	Single
		Multi*
	Croissants	Single
		Multi*
<b>Pies</b>	Apple	Single
	Lemon Meringue	Single

*The information in these charts are guidelines only. Refer to your recipe or the packaging and be prepared to adjust the cooking times and settings accordingly.*

*For models without Bake, Pastry Bake or Classic Bake functions use Fan Forced instead.*

*\* For models without the Fan Forced function we recommend baking on a single shelf only*

RECOMMENDED FUNCTION	SHELF POSITIONS (FULL OVENS)	SHELF POSITIONS (COMPACT OVENS)	TEMP (°C)	TIME (MINS)
Fan Bake	4	2	180-190	13-17
Fan Forced	3 and 5	1 and 3	160-170	13-17
Fan Bake	4	2	180-190	15-20
Fan Forced	3 and 5	1 and 3	160-170	15-20
Pastry/Pizza Bake/Fan Bake	4	2	160-170	12-15
Pastry/Pizza Bake/Fan Bake	3	2	160-165	15-20
Bake	4	2	160-165	30-35
Bake	4	2	160-180	50-60
Bake	2	2	155-165	1hr 30
Classic Bake/Bake	2	2	120-160	2.5 hrs
Bake	2	2	175	30-40
Bake	2	2	170-190	15-25
Pastry/Pizza Bake/Fan Bake	3	2	130-140	20-25
Fan Bake	3	2	180-190	13-17
Fan Forced	2 and 4	1 and 3	160-170	16-21
Fan Bake	2	2	210-230	8-12
Fan Forced	1 and 3	1 and 3	210-230	8-12
Bake	1	2	100-120	60
Bake	4	2	195-210	25-35
Fan Bake	3	2	190-200	15-25
Bake	3	2	185-200	20-30
Bake		2		
Fan Forced	2	1 and 3	200-210	30-35
Bake		-		
Fan Forced	3	1 and 3	190-200	15-25
Pastry/Pizza Bake	2	2	190-200	25-30
Pastry/Pizza Bake	2	2	175-180	30-40

## SAVOURY

FOOD		SHELVES
Pies	Chicken / Steak / Mince	Single
Sausage Rolls		Single
Meat Loaf		Single
Pizza	Classic	Single
	Thin crust	Single
	Deep dish	Single
Lasagne		Single
Quiche		Single
Potatoes	Traditional Baked	Single
Frittata	Grill to finish	Single
Casseroles		Single
Oven meals		Single

## ROASTING

FOOD		SHELVES	
Beef (Boneless)	Rare	Single*	
	Medium		
	Well done		
Prime Rib Roast	Rare	Single*	
	Medium		
	Well done		
Lamb leg (Bone in)	Medium	Single*	
	Well done		
Lamb leg (Boneless)	Medium	Single*	
	Well done		
Veal	Medium	Single*	
	Well done		
Chicken (Whole)		Single*	
Turkey (Whole)	With Stuffing	Single*	
	Without Stuffing		
Pork (Boneless)	Medium	Single*	
	Well done		
Pork Crackling	Crisp		
Venison	Brown in a frying pan first.	Rare	Single*
		Medium	

RECOMMENDED FUNCTION	SHELF POSITIONS (FULL OVENS)	SHELF POSITIONS (COMPACT OVENS)	TEMP (°C)	TIME (MINS)
Pastry/Pizza Bake/Fan Bake	3	2	190-195	30-40
Pastry/Pizza Bake/Fan Bake	3	2	190-195	30-40
Bake	4	2	175-180	55-65
Pastry/Pizza Bake/Fan Bake	1 and 2	2	225-250	8-12
Pastry/Pizza Bake/Fan Bake	1 and 2	2	280*	5-8
Pastry/Pizza Bake/Fan Bake	1 and 2	2	160-220 <sup>1</sup>	50-60
Fan Bake	3	2	175-180	45-50
Pastry/Pizza Bake/Fan Bake	2	2	180-200	30-40
Bake	3	2	175-190	40-50
Pastry/Pizza Bake/Fan Bake	3	2	170-180	30-45
Bake	3	1	170-190	55-70
Fan Forced/Fan Bake	3	2	170-190	30-40

RECOMMENDED FUNCTION	SHELF POSITIONS (FULL OVENS)	SHELF POSITIONS (COMPACT OVENS)	TEMP (°C)	TIME (MINS)
Bake	3	2	160-170	18-32 / 450g
Bake	3	2	160-170	25-40 / 450g
Bake	3	2	160-170	30-55 / 450g
Bake	3	2	160-170	15-30 / 450g
Bake	3	2	160-170	20-35 / 450g
Bake	3	2	160-170	25-40 / 450g
Bake	3	2	160-170	18-28 / 450
Bake	3	2	160-170	20-33 / 450g
Bake	3	2	160-170	20-35 / 450g
Bake	3	2	160-170	25-45 / 450g
Bake	3	2	160-170	20-40 / 450g
Bake	3	2	160-170	25-45 / 450g
Fan Grill	3	2	175-190	15-20 / 450G
Bake	1	1	165-175	17-22 / 450g
Bake	1	1	150-165	15-20 / 450g
Bake	3	2	170-175	25-40 / 450g
Bake	3	2	170-175	30-45 / 450g
Bake	3	2	250	20
Fan Grill	4	1	225	7.5/ 2.5cm meat thickness
Fan Grill	4	1	225	9.5 / 2.5cm meat thickness

## GRILLING

FOOD	SHELVES		
<b>Beef</b>	Steak	Rare	Single
		Medium	Single
	Burgers		Single
	Meatballs		Single
<b>Lamb</b>	Chops	Medium	Single
		Well done	Single
<b>Pork</b>	Chops (well done)		Single
	Ham steak		Single
	Bacon		Single
<b>Chicken</b>	Boneless pieces		Single
<b>Sausages</b>			Single
<b>Fish</b>	Fillets		Single
	Whole		Single
<b>Vegetables</b>	Sliced		Single

RECOMMENDED FUNCTION	SHELF POSITIONS (FULL OVENS)	SHELF POSITIONS (COMPACT OVENS)	TEMP (°C)	TIME (MINS)
Grill	4	3	HI	8-10
Grill	4	3	HI	10-15
Grill	4	3	HI	12-15
Grill	4	3	HI	12-15
Grill	4	3	HI	15-20
Grill	4	3	HI	20-25
Grill	4	3	HI	15-20
Grill	4	3	HI	15-20
Grill	4	3	HI	4-7
Fan Grill	5	2	175-190	30-50
Grill	5	2	HI	10-15
Fan Grill	5	2	200-220	8-12
Fan Grill	5	2	200-220	15-20
Grill	4	3	HI	8-12

## AUTOMATIC COOKING

- You can set the oven to automatically turn on later, cook for a preset time (cooking time), then automatically turn off at a preset stop time. See the example and instructions below (steps 1 to 7).
- If you start cooking manually and only want the oven to turn off automatically after a set cooking time: simply set the cooking time following steps 1 to 4 below and select a function and temperature. The oven will automatically turn off when the cooking time is over.
- Alternatively you may set the time of day you wish the oven to turn off. Follow steps 5-7.
- You may still use the timer when using automatic cooking.
- Note: the grill element will come on while the oven is heating up. Uncovered foods may be browned on top.



**IMPORTANT :** Safe food handling: leave food in the oven for as short a time as possible before and after cooking or defrosting. This is to avoid contamination by organisms which may cause food poisoning. Take particular care during warmer weather.

Example: It is 11:05 a.m. You want your food to cook for 1 hour, and you would like it to be ready by lunchtime (12:30 p.m.)

11:05

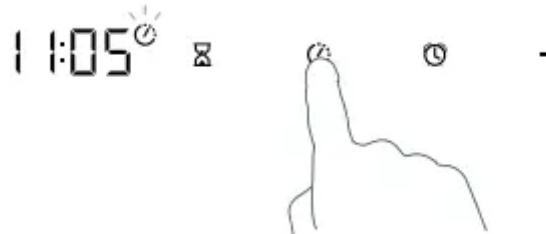
1. Check the clock shows the correct time of day.





2. Touch the cooking time  control. The cooking time  indicator will flash.



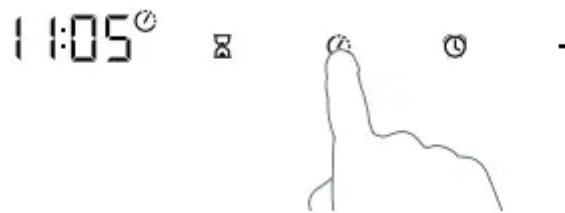

3. Touch the - and + controls to set the cooking time. Make sure you allow for preheat time in your calculation.

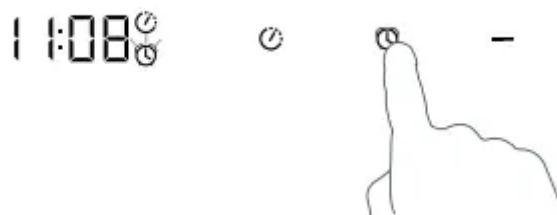

4. Touch the cooking time  control to confirm. The cooking time  indicator will stop flashing and remain on.

### Set the stop time



5. Touch the stop time  control. The stop time A indicator will flash.



6. Touch the - and + controls to set the time you would like your food to be ready by (ie the stop time).



7. Touch the stop time  control to confirm. The A will stop flashing and remain on and the display will show the time of day.

### Select function and temperature

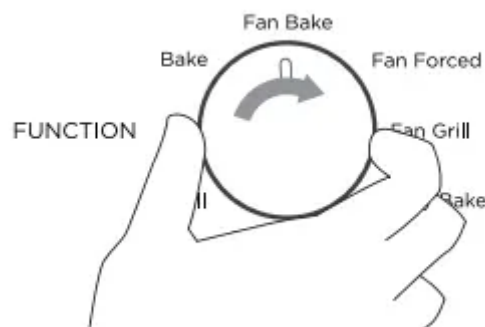

8. Select a function

- The oven will come on. Note: if you have set the oven to automatically turn on later, the oven cooling fan will come on when you select a function, but the light will be off and the oven will not heat up.

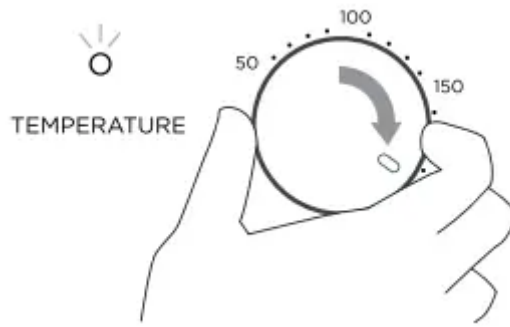

9. Set the temperature.



#### **When automatic cooking is set**

- The oven lights will stay off but your oven is now set for automatic cooking. It will automatically heat up at the required time.
- The display will show the time of day with the cooking time  and stop time A indicators lit. The cooling fan will continue to run.
- Note: you can modify the function and temperature before and during cooking.

#### **To check the set cooking time**

Touch the cooking time  control.

#### **To modify the set cooking time**

Touch the cooking time  control. The cooking time  indicator will flash. You can modify the set cooking time by using the - and + controls. Touch the cooking time  control again to set.

#### **To cancel the Cooking time**

Touch the stop time  control. Touch the - control and scroll the time down to

**0:00**



Touch the cooking time  control to accept.

- Note: this will not turn off the oven. If the stop time is set the oven will turn off when the stop time is reached.

#### **To check the stop time**



Touch the stop time  control.

#### **To modify the stop time**

Touch the stop time  control. The stop time A indicator and dot will flash. You can modify the set cooking time by using the - and + controls. Touch the stop time  control again to set.

- Scrolling the time down will not turn off the oven.

### To cancel automatic cooking

Touch the cooking time  control and the stop time  control together for two seconds.

Turn the function and temperature dials to O Off

### When the stop time is reached

The oven will automatically turn off and the oven will beep every 7 seconds. The cooking time  and the stop time A indicator will flash. Turn the function and temperature dials back to O Off. Press any control to exit automatic cooking.

- Note: if the oven function dial has not been turned back to O Off when you exit automatic cooking, the oven will turn back on.

## CARE AND CLEANING

### Manual cleaning

#### ALWAYS

- Before any manual cleaning or maintenance, first wait for the oven to cool down to a safe temperature to touch, then turn its power supply off at the wall.
- Read these cleaning instructions and the 'Safety and warnings' section before you start cleaning your oven.
- To prevent soiling from becoming 'baked on' and stubborn, we recommend removing any easy-to-reach spills, food or grease stains from the oven cavity enamel after each use.

#### NEVER

- Never use a steam cleaner.
- Never store flammable substances in the oven.
- Never use abrasive or harsh cleaners, cloths, scouring pads or steel wool. Some nylon scourers may also scratch. Check the label first.
- Never use oven cleaner on catalytic panels (some models only).
- Never leave alkaline (salty spills) or acidic substances (such as lemon juice or vinegar) on the oven surfaces.
- Never use cleaning products with a chlorine or acidic base.

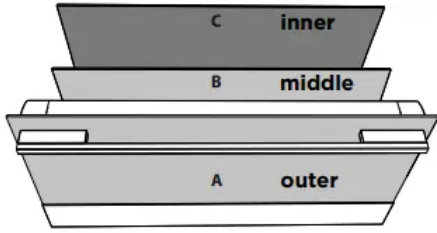
WHAT?	HOW?	IMPORTANT!
<p>Glass surfaces (oven door panes, control panel)</p>	<p>Door comprises a total of 3 glass panes</p>  <p>● To clean glass pane B, you will first need to remove the door and the inner pane. For instructions, see section 'Removing and replacing the door glass panes for cleaning'.</p> <ol style="list-style-type: none"> <li>1. Clean with a solution of mild detergent and hot water. We recommend using a soap containing potassium hydroxide. Wearing gloves, dampen the soap bar and smear the soapy mixture on the door glass. Leave for 15 minutes then rinse with clean water and wipe dry.</li> <li>2. Wipe with a glass cleaner and dry with a soft, lint-free cloth.</li> </ol>	<ul style="list-style-type: none"> <li>● Don't use oven cleaners or any other harsh/abrasive cleaners, cloths, scouring pads, steel wool or sharp metal scrapers to clean the glass surfaces. These scratch the glass and may damage its special coating, which in turn could result in the glass cracking or shattering.</li> <li>● Even if you only clean the inner pane (C), remove the door and the pane first. Cleaning the glass with the pane in the door may result in cleaning liquid running down the gaps and drying onto internal components.</li> <li>● Take particular care when cleaning the control panel glass. Only use a damp cloth with detergent.</li> </ul>
<p>Dials</p>	<p>Clean with a solution of mild detergent and hot water, then wipe dry.</p>	<p>Do not use stainless steel or oven cleaner on the dials, as doing so may damage their coating.</p>
<p>Stainless steel strip/handle on the front of the oven door</p>	<ul style="list-style-type: none"> <li>● Clean with a solution of mild detergent and hot water, then wipe dry with a microfibre cloth.</li> <li>● If necessary, use a suitable stainless steel cleaner and polish</li> </ul>	<ul style="list-style-type: none"> <li>● Always read the label to make sure that your stainless steel cleaner does not contain chlorine compounds as these are corrosive and may damage the appearance of your oven.</li> <li>● Always rub the stainless steel in the direction of the grain.</li> </ul>
<p>Oven door frame and</p>		

plastic corner clips	Clean with a solution of mild detergent and hot water, then wipe dry.	
Catalytic panels (some models only)	<p>To clean light soiling off the surfaces:</p> <ol style="list-style-type: none"> <li>1. Wipe with a damp cloth and a solution of hot water and mild detergent or an ammonia-based cleaner.</li> <li>2. Wipe dry with a soft cloth.</li> </ol> <ul style="list-style-type: none"> <li>● To clean stubborn, 'baked on' soiling run the oven on Fan Grill at 200°C for 1.5 hours to enhance the catalytic panel cleaning function.</li> </ul>	<ul style="list-style-type: none"> <li>● These panels are normally 'self-cleaning' because their special enamel breaks down greasy splatters when the oven is used for 'non-greasy' baking, especially at high temperatures.</li> <li>● Do not use oven cleaner on the catalytic panels. If you wish to use oven cleaner on any other part of the enamelled cavity, first remove the catalytic panels.</li> <li>● Do not immerse catalytic panels in water.</li> <li>● Never use scourers, brushes, abrasives or cleaners with acid or alkali content on the catalytic panels.</li> </ul>
Drip channel	Use a sponge to soak up any moisture that has collected in the drip channel, below the door	
Oven cavity	<ul style="list-style-type: none"> <li>● Remove everything from the oven: all shelves and trays, the side racks, the catalytic panels (if purchased separately).</li> </ul> <ol style="list-style-type: none"> <li>1. Remove the oven door (see instructions on following pages).</li> <li>2. Wipe the inside of the oven using a household detergents or an ammonia-based cleaner. 3 Wipe clean with a damp cloth and allow to dry completely</li> </ol>	<ul style="list-style-type: none"> <li>● To prevent soiling from becoming 'baked on' and stubborn, we recommend removing any easy-to-reach spills, food or grease stains from the enamelled surfaces after each use.</li> <li>● To make wiping out the oven easier you may remove and the oven door. See the following pages for instructions.</li> <li>● To make cleaning the oven ceiling easier, the grill element can be lowered. See following pages for instructions</li> </ul>

Telescopic sliding shelf supports (some models only)	Wipe with a damp cloth and mild detergent. Do not wipe off or wash away the white lubricating grease (visible when the slides are extended).	Do not wash these in the dishwasher or immerse in soapy water. Do not use oven cleaner on them; as doing so will remove the white lubricating grease and prevent the slides from running smoothly.
Grill tray Grill rack Side racks Oven shelves Baking tray	<ul style="list-style-type: none"> <li>• Clean with a solution of mild detergent and hot water.</li> <li>• Pre-soak stubborn burnt-on stains in a solution of dishwasher powder and hot water.</li> <li>• Except for the baking tray these parts are also dishwasher safe.</li> </ul>	
Oven seal	Clean with a solution of mild detergent and hot water.	

### Drop-down upper element

**IMPORTANT :** Always turn off the oven at the wall before lowering the upper element. Make sure the oven has cooled down completely before starting.

- To lower the upper element: pull the two securing clips gently forward to release the element. The element will now drop down to enable cleaning.
- When you have finished cleaning the oven ceiling, pull the securing clips forward, raise the element and release the clips. Make sure the element is securely held in place.
- The element itself is self-cleaning.

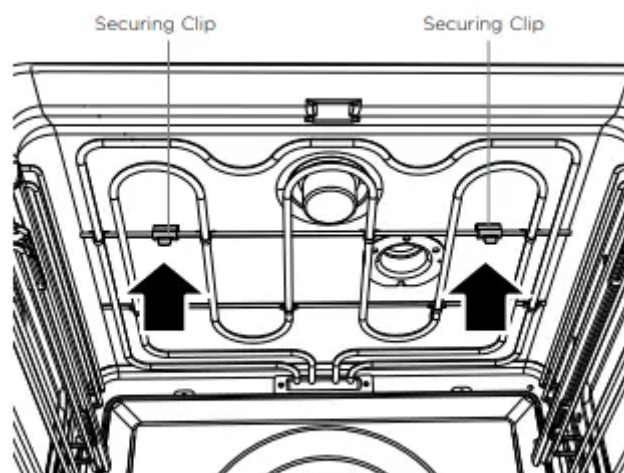

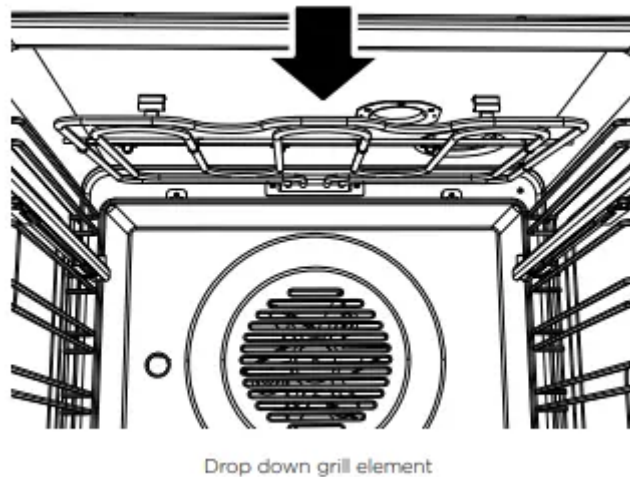

### Removing the side racks and catalytic panels (some models only, purchased separately)

**IMPORTANT :** Always turn off the oven at the wall first. Ensure the oven has cooled down completely before starting.

#### Remove all shelves

1. Slide out all shelves and remove. For easier access we recommend removing the oven door. See 'Removing and refitting the oven door'.

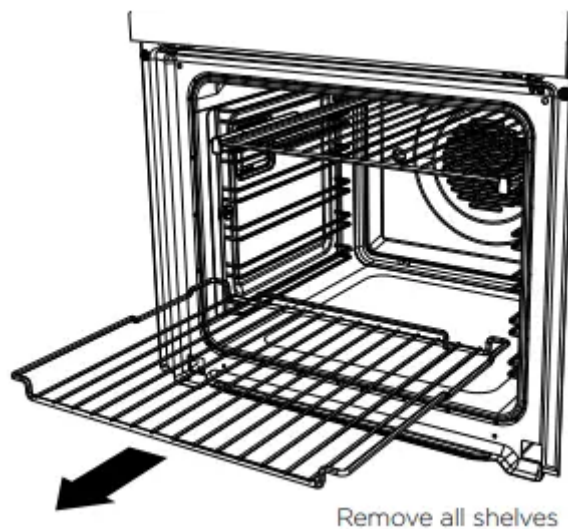

#### Remove both side racks (and catalytic panels if fitted):

1. Unscrew and remove the fixing nut at the front of the side rack. Use a coin to loosen the nut if necessary.
2. Pull the side rack toward the center of the oven until the front tab is clear of the fixing nut. If catalytic panels are fitted remove them at the same time (pull the panel toward the centre of the oven along with the side rack).

3. Slide the side rack (and catalytic panel if fitted) forward until the rear prongs are clear of the holes.

4. You may now slide the catalytic panel off the side rack rear prongs.

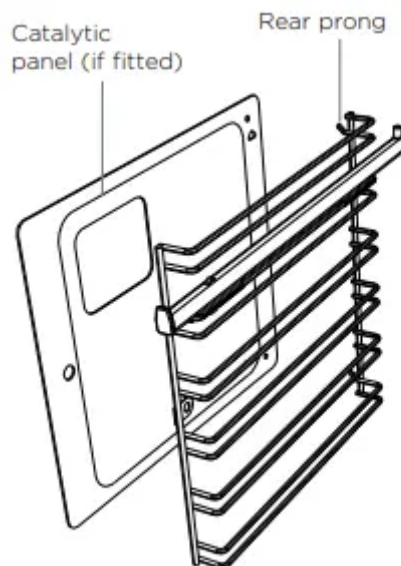
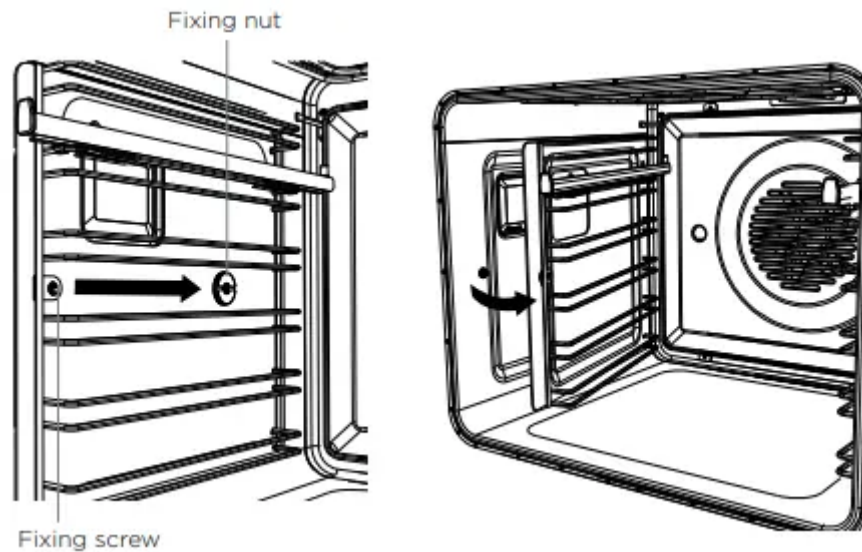

### **Refitting the side racks and catalytic panels (some models only, purchased separately)**

#### **Fit the catalytic panel to the side rack**

1. Ensure the panels are placed the correct way around: in models with side lights: the cutout fits over the light and the hole for the fixing screw goes to the front of the oven. in models with a ceiling light: the hole for the fixing screw goes to the front of the oven. (Note: panels should sit flush against the oven wall).
2. Fit the rear prongs of the side rack through the holes in the catalytic panel.

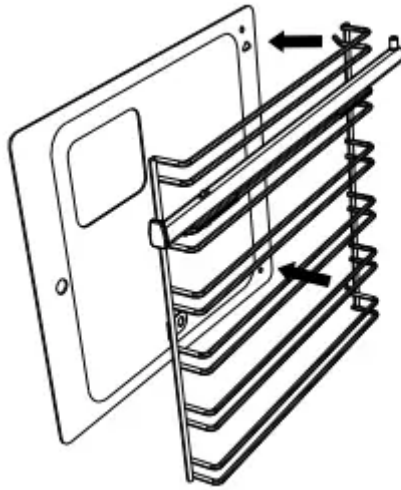

### Replace the side racks

1. Slide the rear prongs of the side rack into the holes at the rear of the oven
2. Fit the side rack front tab (and catalytic panel if fitted) over the fixing screw.
3. Replace the fixing nut. You may use a coin to tighten the nut.

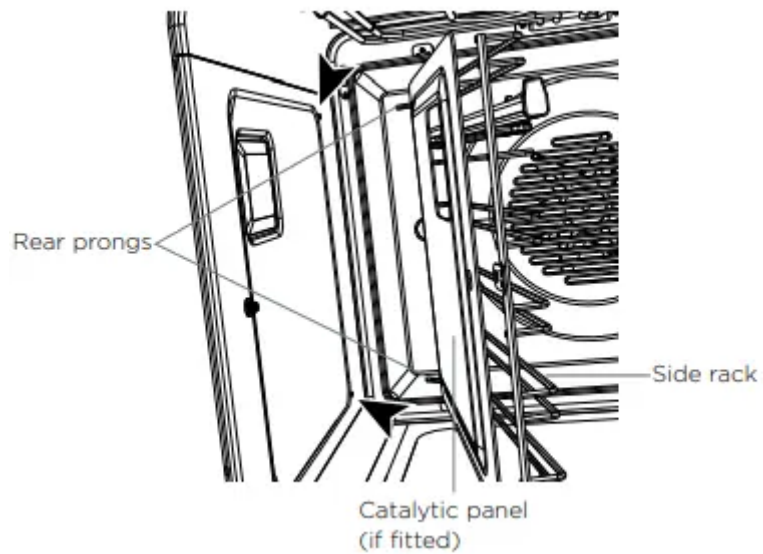

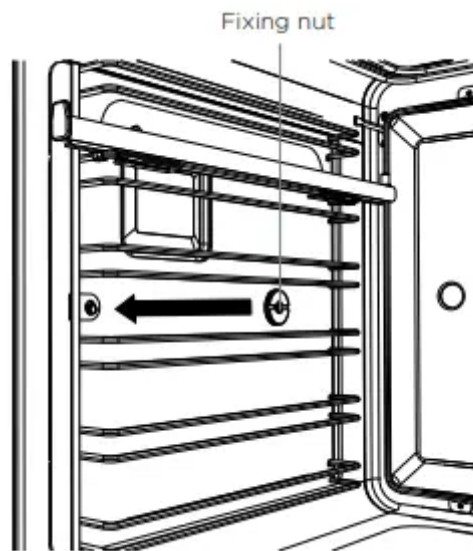
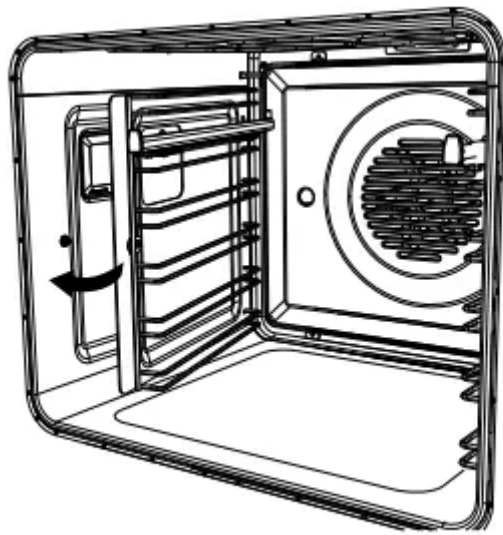

### Removing and refitting the sliding shelf supports

**IMPORTANT :** Compact ovens only: The sliding shelf supports cannot be used on shelf positions 3 and 4.

#### To fit

1. Ensure the slides are the correct way around (the front of the slide has the triangular shaped tab as shown).
2. Fit the top of the clips over the side rack, the front clip should be fitted as close to the front of the side rack as possible. Make sure the rear clip has engaged.
3. Rotate the slide down and 'click' the bottom of the clips into place

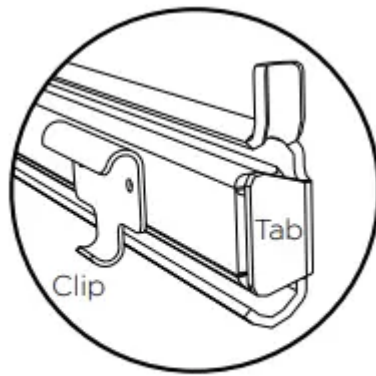

Front of Left Hand Slide

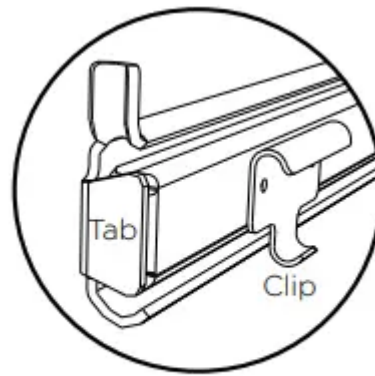

Front of Right Hand Slide

### To remove

- Grasp the slide and rotate the bottom up to release the the clips and remove.

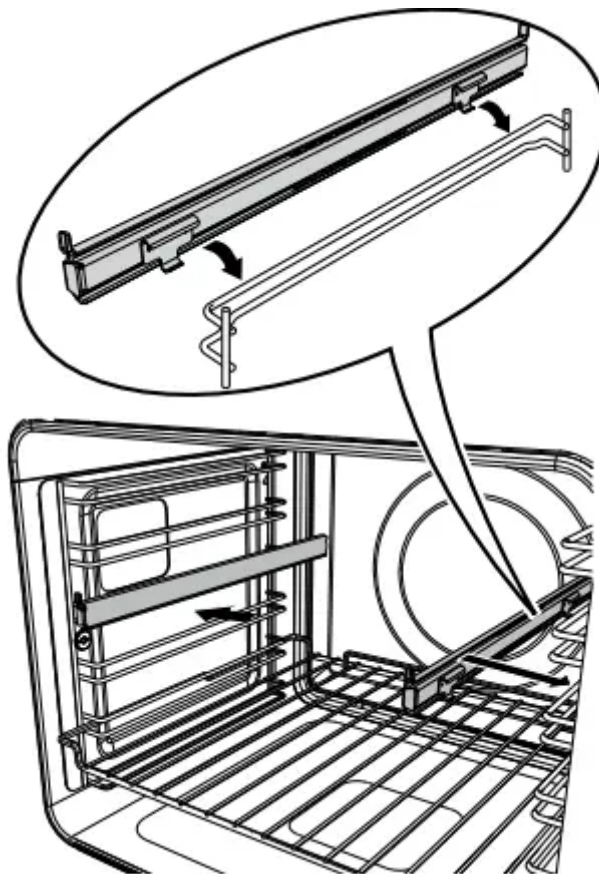

### When refitting the sliding shelf supports, make sure that you fit:

- the side racks first.
- the slides to the top wire of a shelf position (shelf positions 1 & 2 only in compact ovens)
- both sides of each pair of slides.

### Refit the oven shelves and grill pan

- Slide in the shelves you need, making sure that:

- They slide between the two wires of a shelf position (unless a sliding shelf support is being use)
- The stop notches point down
- The guard rail is to the rear.

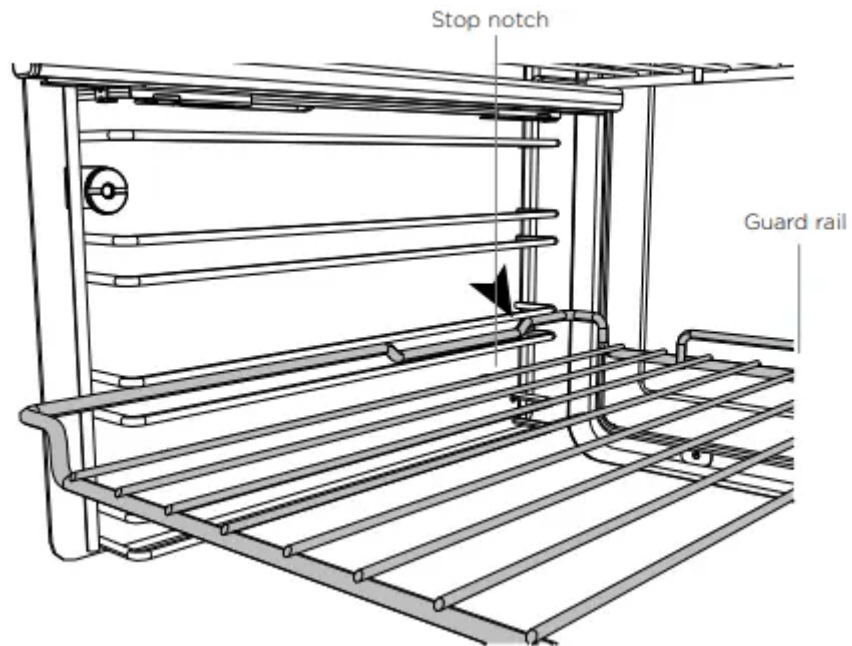

Refitting the shelf between two wires

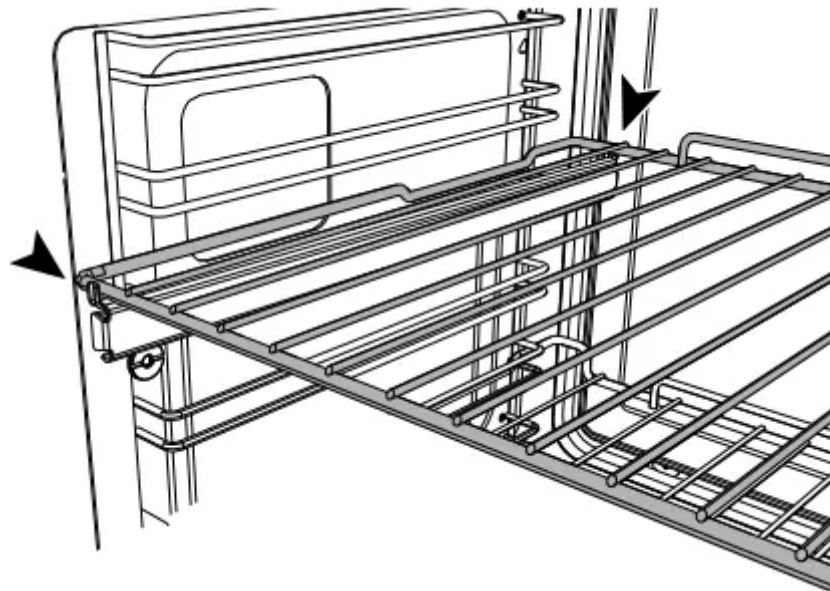

Refitting the shelf onto a sliding shelf support

**Removing and refitting the oven door.**

IMPORTANT : Take care, the oven door is heavy

**To remove the door**



1. Open the door fully. Locate the two small metal locking levers on both door hinges either side.

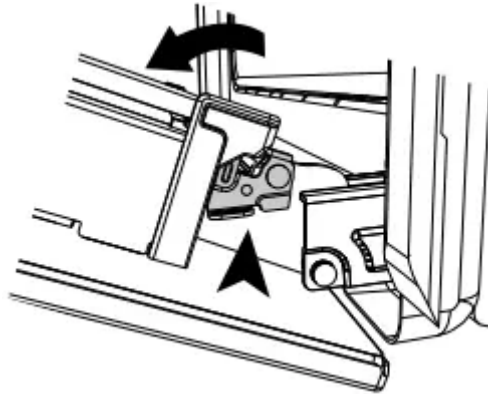

2. Push each locking lever down fully to release the door from the hinge.

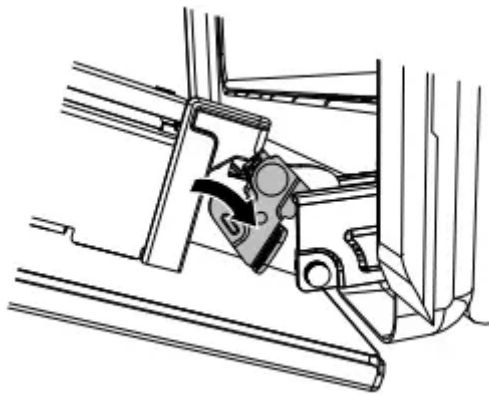

3. Holding the door on both sides, lift door back up to 45o and carefully pull the door out and away from the hinges.

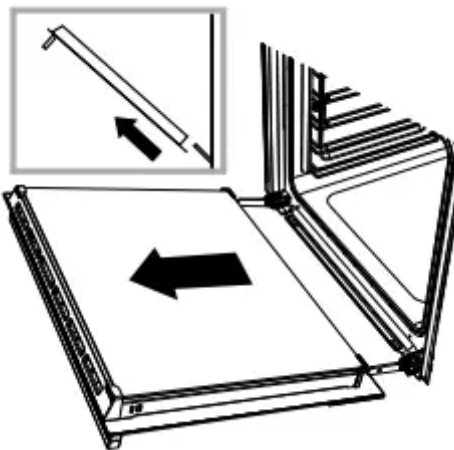

### To refit the door

4. Holding the door on both sides, line up the holes in the base of the door with the hinges and slide the door on.

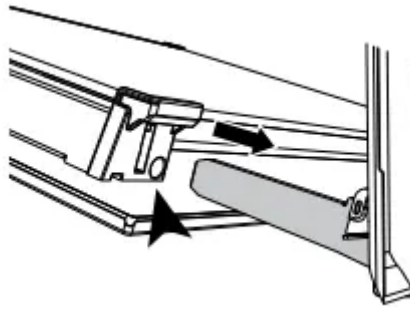

4. Once the door is fully located on the hinges, push each locking lever up fully to lock the door onto the hinge.

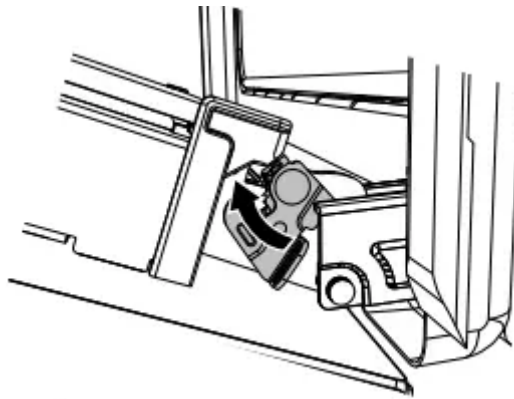

4. IMPORTANT : Ensure the levers are both fully locked before trying to shut the door.

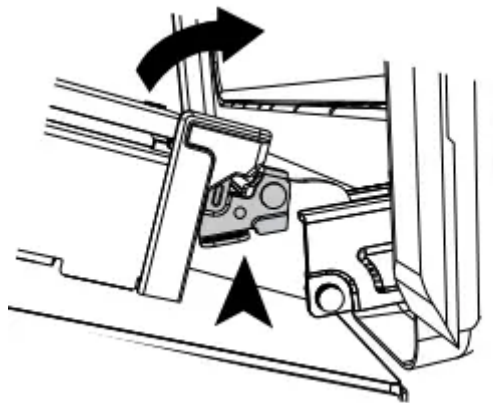

### Removing the door glass panes for cleaning

#### IMPORTANT

- Make sure you follow the precautions and instructions below very carefully. Replacing the glass panes and the door incorrectly may result in damage to the oven and may void your warranty.
- Take care, the oven door is heavy. If you have any doubts, do not attempt to remove the door.
- Make sure the oven and all its parts have cooled down. Do not attempt to handle the parts of a hot oven.

- Take extreme care when handling the glass panes. Avoid the corners and edges of the glass bumping against any surface. This may result in the glass shattering.
- Don't use oven cleaners or any other harsh/abrasive cleaners, cloths, scouring pads, steel wool or sharp metal scrapers to clean the glass surfaces. These scratch the glass and may damage its special coating, which in turn could result in the glass cracking or shattering.
- If you notice any sign of damage on any of the glass panes (such as chipping or cracks), do not use the oven. Call your Authorised Repairer or Customer Care.
- Make sure you replace all the glass panes correctly. Do not use the oven without all glass panes correctly in place.
- If the glass panes feel difficult to remove or replace, do not force them. Call your Authorised Repairer or Customer Care for help.

### To remove the inner pane

1. Press the glass retainer tabs in on both sides of the door.
2. Pull the glass retainer strip until the tabs relocate in the topmost hole.
3. Holding the top of the inner pane, gently pull the pane toward the top of the door until the pane is clear of the clamp at the bottom of the door and lift out. Do not angle the pane too much as you may damage the glass.

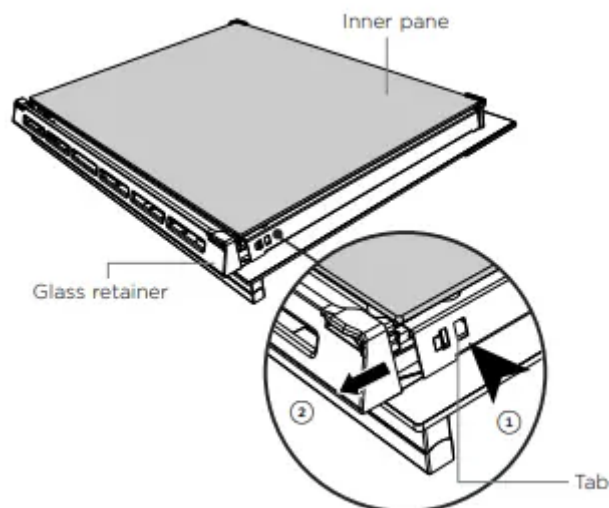

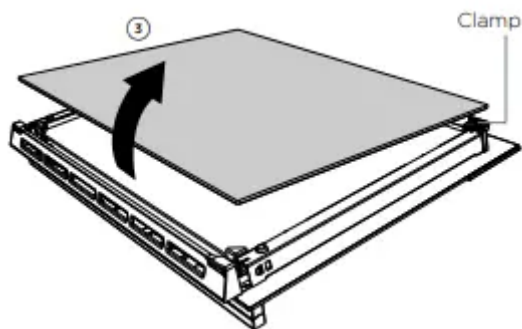

### To remove the middle pane

4. Press the glass retainer tabs in on both sides of the door again. The glass retainer can then be pulled off completely.
5. Gently pull the middle pane toward the top of the door until the pane is clear of the clamp at the bottom of the door.
6. Lift the pane out. The rubber stoppers at the top of the pane remain attached to the glass pane.

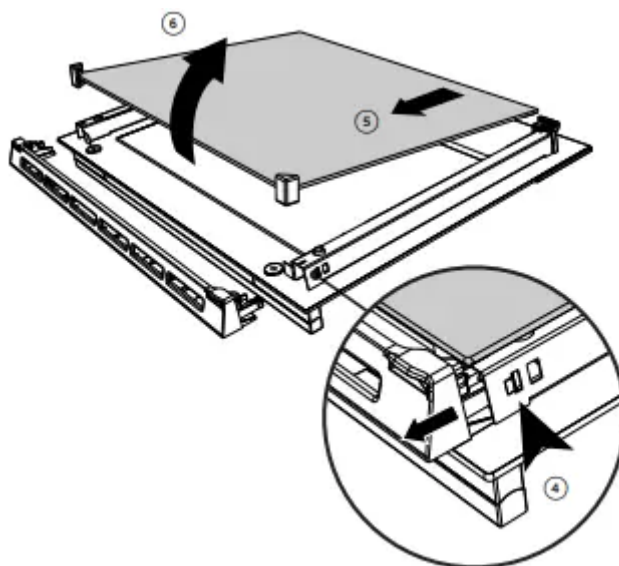

### After cleaning replace the door glass panes

#### When replacing the glass panes make sure that

- you replace the inner pane correctly as shown. The pane must be in the position described below in order to fit into the door and to ensure that the oven operates safely and correctly
- you take extra care not to bump the edges of the glass against any object or surface you do not force any of the panes into place. If you are experiencing difficulties replacing the panes, remove them and start the process again from the beginning. If this still does not help, call Customer Care

#### Replace the middle pane

Ensure the pane is the right way up (the black strip and warning text at the bottom of the pane should be readable back to front when the pane is fitted correctly).

1. Ensure the rubber stoppers are still attached at the top to the pane.
2. Slot the bottom of the pane into the lower notch at the bottom of the door.
3. Lower the pane into the door, the rubber stoppers rest on the outer pane of glass.

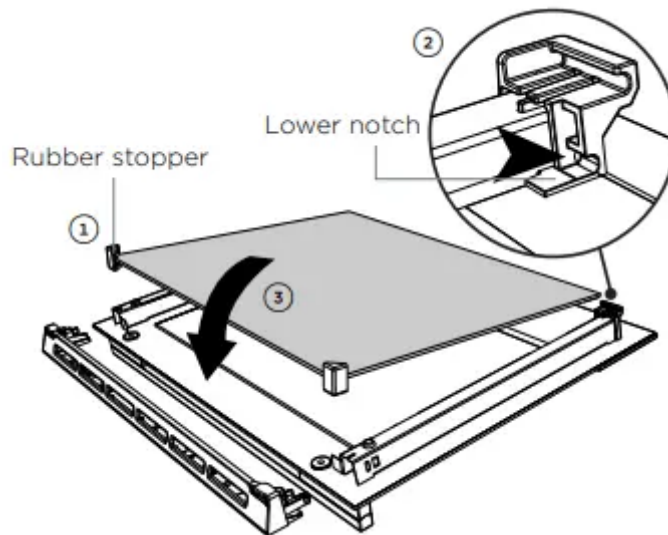

### **Replace the inner pane**

Ensure the pane is the right way up (ie the logo should be readable at the bottom of the door)

4. Slide the pane into the notch at the bottom of the door.
5. Lower the pane onto the clamp at the top of the door.
6. Slide the glass retainers back into place and ensure they are clipped securely in place

**IMPORTANT :** Make sure the glass retainers are correctly and firmly in place and the glass pane is secure.

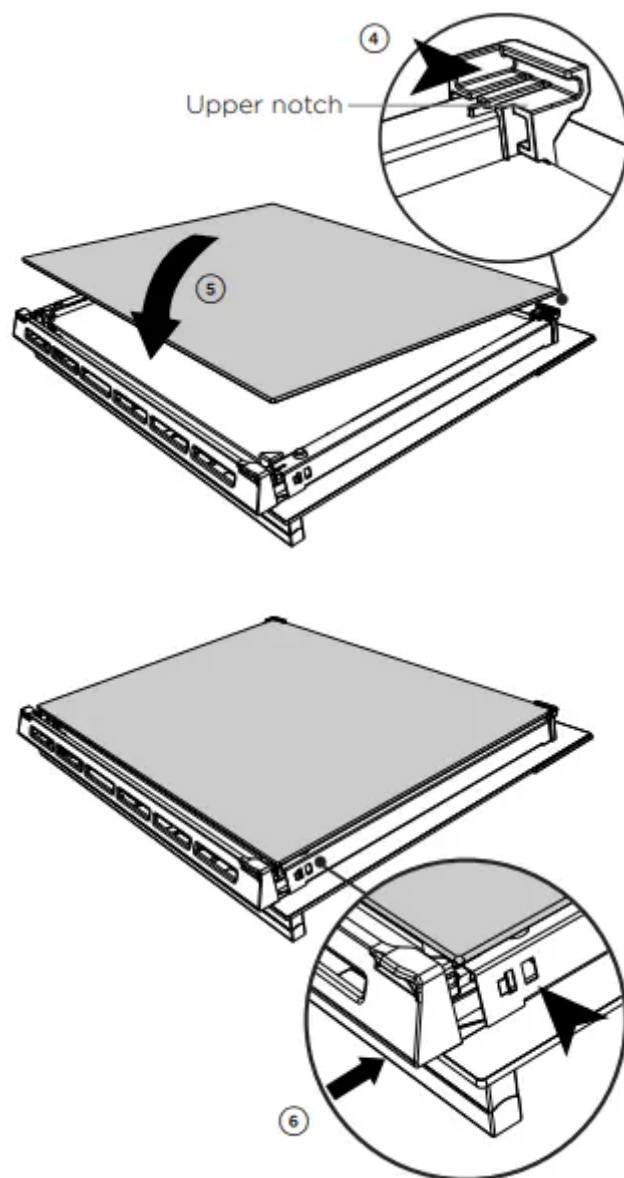

## Replacing the oven light bulbs

### Models with ceiling mounted light

Note: Oven bulb replacement is not covered by your warranty. The light is located in the ceiling of the oven, center front. Your oven uses G9 halogen bulbs with the specifications 220-240V, 50Hz and 25W. Always hold the replacement bulb in a soft cloth. Touching the bulb will reduce its lifespan.

### Changing the bulb

1. Let the oven cavity and grill element cool down before changing the bulb.1  
Let the oven cavity and grill element cool down before changing the bulb.
2. Turning anti-clockwise unscrew the glass cover (B).
3. Carefully pull out the faulty halogen bulb (A).
4. Replace the light bulb (A)

5. Replace the glass cover (B).
6. Turn the oven back on and set the clock (see 'First use' for instructions).

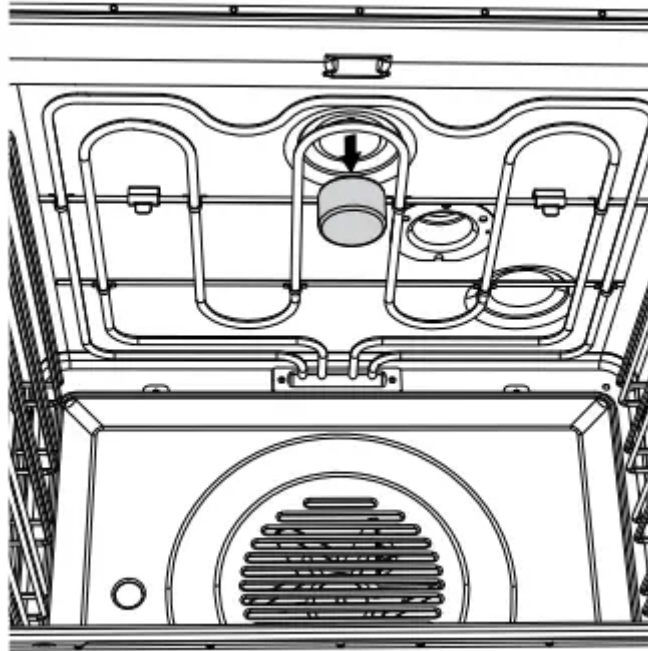

### **Models with side mounted lights**

Note: Oven bulb replacement is not covered by your warranty. Your oven uses G9 halogen bulbs with the specifications 220-240V, 50Hz and 25W. Always hold the replacement bulb in a soft cloth. Touching the bulb will reduce its lifespan. The two oven lights are located behind the opaque glass panels on each side wall of your oven (one on each side).

### **Changing the bulb**

1. Let the oven cavity and grill element cool down before changing the bulb. Before switching off the oven, take note of which light(s) are not working.
2. Remove the oven shelves and side racks (see 'Care and cleaning'). If fitted, remove catalytic panels.
3. Pull the glass cover off (if you find this difficult, you can gently prise the cover off using the handle of a spoon or similar in the notches between the glass panel and oven wall while holding the cover to ensure it does not fall).
4. Pull out the faulty bulb.
5. Holding the replacement bulb in a soft cloth or tissue (touching the bulb will reduce its life span) insert it into the socket.
6. Replace the glass cover pushing it firmly into place.
7. Replace the catalytic panels (if fitted), side racks and oven shelves .

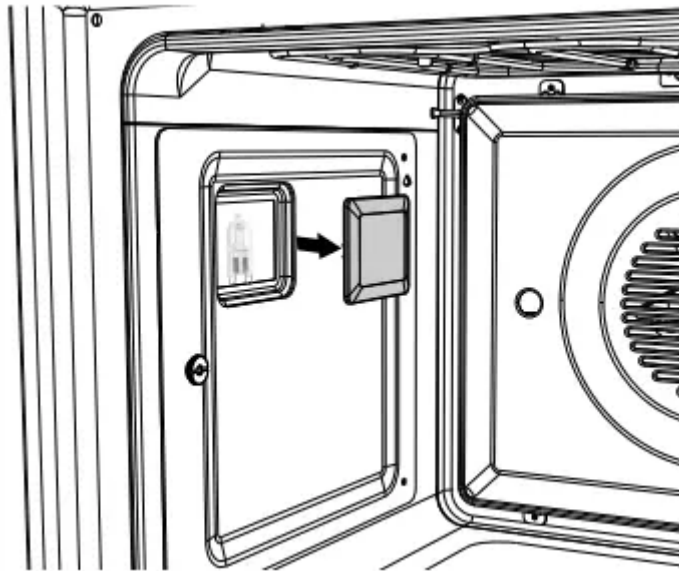

# TROUBLESHOOTING



<b>PROBLEM</b>	<b>POSSIBLE CAUSES</b>	<b>WHAT TO DO</b>
The oven does not work.	No power.	Check that the mains power supply (wall switch) is turned on, the fuse has not tripped and there is no power outage in your area.
	The clock has not been set.	The oven will not function until the clock is set. See 'First use' for instructions on setting the clock.
The oven does not work but the display is lit.	The oven is set for automatic cooking.	See 'Automatic cooking' for instructions
The oven light does not come on when I select a function.	The clock has not been set.	The oven will not function until the clock is set. See 'First use' for instructions on setting the clock.
	The oven light bulb(s) have blown.	Replace the light bulb(s). See 'Care and cleaning' for instructions
The oven light does not come when I open the door	This is normal.	The oven light only comes on when you have selected a cooking function.
The oven is not heating.	The door is opened too frequently during cooking.	Make sure the door is properly closed and avoid opening it frequently during cooking.
	The clock has not been set.	The oven will not function until the clock is set. See 'First use' for instructions on setting the clock.
The oven cancels automatic cooking when I adjust the clock setting.	The oven was set for automatic cooking when you were trying to adjust the clock setting.	You can only adjust the clock setting while the oven is not set for automatic cooking. See section 'Setting the clock and first use' for instructions.
A glass pane in the oven door has cracked, chipped, or shattered.	Incorrect cleaning or the edge of the glass hitting against something.	You must NOT use the oven. Call your Authorised Repairer or Customer Care.
The oven fan turns on again several minutes	This is normal.	

after I have turned off the oven.		If the oven is over a certain temperature the cooling fan will automatically turn on to cool the oven down.
The oven fan stays on when I set a delayed start with Automatic cooking.	This is normal.	The oven will not heat up until the start time is reached.

## SAFETY AND WARNINGS

### IMPORTANT SAFETY INSTRUCTIONS

To reduce the risk of fire, electrical shock, injury to persons or damage when using the oven, follow the important safety instructions listed below:

- Read all the instructions before using the oven. Use the oven only for its intended purpose as described in these instructions.
- Proper installation: be sure your appliance is properly installed and earthed by a qualified technician.
- Isolating switch: make sure this oven is connected to a circuit which incorporates an isolating switch providing full disconnection from the power supply.
- Household appliances are not intended to be played with by children.
- Do not leave children alone. Children should not be left alone or unattended in the area where the appliance is in use. They should never be allowed to sit or stand on any part of the appliance.
- Children of less than 8 years old must be kept away from the appliance unless continuously supervised. This appliance can be used by children aged from 8 years and above, and persons with reduced physical, sensory or mental capabilities or lack of experience and knowledge, if they have been given supervision or instruction concerning the use of the appliance in a safe way and they understand the hazards involved. Cleaning and user maintenance shall not be done by children without supervision.
- Do not place heavy objects on the oven door.
- Wear proper apparel. Do not wear loose fitting or hanging garments when using the appliance. They could ignite or melt if they touch an element or hot surface and you could be burned.
- User servicing: do not repair or replace any part of the appliance unless specifically recommended in the manual. All other servicing should be referred to a qualified technician.

- Do not use water on grease fires. Smother the fire or flame or use a dry chemical or foam type extinguisher.
- Use only dry oven mitts or potholders. Moist or damp potholders on hot surfaces could result in burns from steam. Do not let potholders touch hot areas or heating elements. Do not use a towel or a bulky cloth for a potholder. It could catch fire.
- Do not heat unopened food containers. They can build up pressure that may cause the container to burst and result in injury.
- Safe food handling: leave food in the oven for as short a time as possible before and after cooking. This is to avoid contamination by organisms which may cause food poisoning. Take particular care during warm weather.
- Always keep oven vents unobstructed.
- Do not operate your appliance by means of an external timer or separate remote-control system.
- Caution: Hot air can blow from the vent at the top of the oven as part of the oven's cooling system.
- Placement of oven shelves: always position shelves in the desired location while the oven is cool (before preheating). If a shelf must be removed while the oven is hot, do not let the oven mitts or potholder contact hot heating elements in the oven or the base of the oven.
- Do not clean the oven seal or use any oven-cleaning products on it. It is essential for a good seal, which ensures that the oven operates efficiently. Care should be taken not to rub, damage or move it.
- Do not use oven cleaners, harsh/ abrasive cleaning agents, waxes, or polishes. No commercial oven cleaner, oven liner, or protective coating of any kind should be used in or around any part of the oven. Do not use harsh/abrasive cleaners, scourers or sharp metal scrapers to clean the oven door glass since they scratch the surface, which may result in the glass shattering.
- Clean only the parts listed in this manual.
- Do not use a steam cleaner to clean any part of the oven.
- Do not store things children might want above the oven. Children could be burned or injured while climbing on the oven to retrieve items.
- Do not install or operate the appliance if it is damaged or not working properly. If you receive a damaged product, contact your dealer or installer immediately.
- Use only bakeware approved for oven use. Follow the bakeware manufacturer's instructions.

### **Warning**

This content is compiled from multiple sources and is provided for reference purposes only. It may not be complete or fully applicable to all situations. If you are unable to resolve your issue, please contact the product manufacturer or an authorized service provider for official support.

---

Document generated by [ManualsFile](#)

