

## USING THE RANGE

### Surface Units

#### Operating the Cooktop Elements

Before using the cooktop for the first time, clean it with CERAMA BRYTE® Ceramic Cooktop Cleaner. This helps protect the top and makes cleanup easier.

Turn element(s) On: Touch and hold On/Off pad about half a second. A chime can be heard with each touch to any pad.

Power level can be selected in any of the following ways:

1. Swipe the gray arc (on the graphics) to the desired power level. There is no sensor on the LEDs, or;
2. Touch Anywhere along the gray arc, or;
3. Touch + or - pads to adjust power level, or;
4. Shortcut to Hi: Immediately after turning unit on, touch the + pad, or;
5. Shortcut to Low: Immediately after turning unit on, touch the - pad.

NOTE: When changing from a high heat setting to a lower heat setting, the surface unit may stop glowing. This is normal. The unit is still on and hot.

NOTE: This cooktop has a rapid heat-up feature. If the cooktop is cool when turned on, it will glow red for a short period of time until the desired power setting is reached

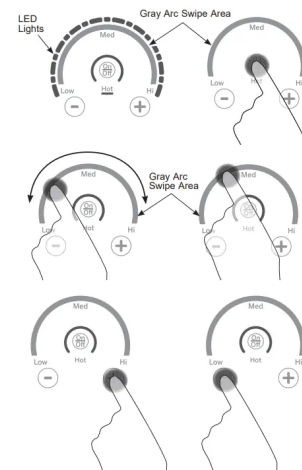

#### Multi-Ring Burner (Can be Dual or Triple)

### To Turn On/Off

1. Touch the On/Off pad for the right front surface unit.
2. Use the arc or + or - pad to choose the desired power setting
3. Touch the Burner Size pad as needed to select the desired burner size.

The light next to the Burner Size pad indicates which size the surface unit is on. To turn the surface unit off, touch the On/Off pad.

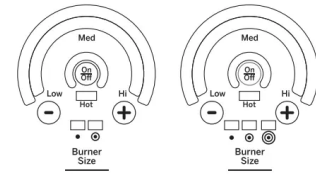

## Oven Controls

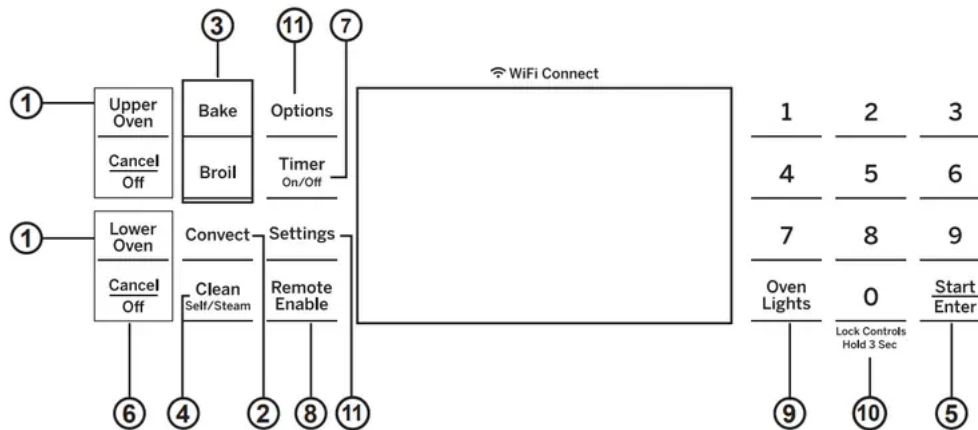

- 1. Upper Oven and Lower Oven:** Designates which oven the controls will operate. Select an oven before following the steps for starting a cooking or cleaning mode.
- 2. Convection Cooking Modes:** Convection cooking modes use increased air circulation to improve performance. See the Cooking Modes section for more information.
- 3. Traditional Cooking Modes:** Your oven has the following traditional cooking modes: Bake, Broil, and Warm. See the Cooking Modes section for more information.
- 4. Clean:** Your oven has two cleaning modes: Self Clean and Steam Clean. See the Cleaning the Oven section for important information about using these modes.
- 5. Start/Enter:** Must be pressed to start any cooking, cleaning, or timed function. Also used to start the Warming Zone on the cooktop.
- 6. Cancel/Off:** Cancels ALL oven operations except the clock and timer. Does NOT cancel the Warming Zone on the cooktop.

**7. Timer:** Works as a countdown timer. Press the **Timer** pad and number pads to program the time in hours and minutes. Press the **Start** pad. The timer countdown is complete. To turn the timer off press the **Timer** pad.

**8. Remote Enable:** Allows you to control your oven remotely. The oven must be connected to WiFi before Remote Enable can be activated. For instructions on how to connect your oven, see the WiFi Connect/Remote Enable section under Settings in this manual.

**9. Oven Light:** Turns the oven light on or off.

**10. Lock Controls:** Locks out the control so that pressing the pads does not activate the controls. Press and hold the **0** pad, for three seconds to lock or unlock the control. **Cancel/Off** is always active, even when the control is locked.

**11. Options and Settings:** The Options and Settings pads open up more detailed menus in the display that allow access to additional functions and cooking modes. For each you select the function in the display using the associated number pad. You can exit at any time by pressing the **Options** or **Settings** pad again. See the Settings, Options, and Cooking Modes Sections for more details.

## Sabbath Mode

The Sabbath mode feature complies with standards set forth by Star K. Some of these standards that will be noticed by the consumer include the disabling of tones, disabling of oven lights, and delays of about 30 seconds to one minute on display changes. Only continuous baking or timed baking is allowed in the Sabbath mode. Cooking in the Sabbath mode is a two-step process, first the Sabbath mode must be set and then the bake mode must be set.

### Setting the Sabbath Mode

Press the **Settings** pad, select **Sabbath**, and select **Turn on**. A single bracket "]" will appear in the display indicating that the Sabbath mode is set. The clock will not be displayed. Continuous bake or timed bake can now be programmed.

### Starting a Continuous Bake

1. Press the **Bake** pad. (For double ovens, this operates the upper oven. If desiring to use Lower Oven, press **Lower Oven** and then **Bake**.)
2. If the desired temperature is 350F, press **Start/ Enter**. If a different cooking temperature is desired, use the **1** through **5** number pads to select a preset cooking temperature, then press **Start/Enter**. Refer to the graphic below to determine which pad sets the desired cooking temperature.

After a delay, a second bracket "[[" will appear in the display indicating that the oven is baking.

Temperature (°F)	<b>1</b>	<b>2</b>	<b>3</b>
	200	250	300
Time (hours)	<b>4</b>	<b>5</b>	<b>6</b>
	325	400	2h
	<b>7</b>	<b>8</b>	<b>9</b>
	2.5h	3h	3.5h
	<b>Cancel</b> <b>Off</b>	<b>0</b>	<b>Start</b> <b>Enter</b>
		Lock Controls Hold 3 Sec	
		4h	

1 = 200° F, 2 = 250° F, 3 = 300° F, 4 = 325° F, 5 = 400° F

6 = 2 hours, 7 = 2.5 hours, 8 = 3 hours, 9 = 3.5 hours, 0 = 4 hours

### Adjusting the Temperature

Press **Bake** (or press **Lower Oven** and then **Bake** for lower oven in a double oven unit), use the **1** through **5** number pads to select a different preset cooking temperature, and press **Start/Enter**.

### Starting a Timed Bake

1. Press the **Bake** pad.
2. If the desired temperature is 350F, use the **6** through **0** number pads to select a cooking time. If a cooking temperature other than 350F is desired, use the **1** through **5** number pads to select a preset cooking temperature, then select the cooking time. Refer to the graphic on this page to determine which pad sets the desired cooking temperature and cooking time.
3. Press **Start/Enter**.

After a delay, a second bracket "]" [" will appear in the display indicating that the oven is baking. When the cook time expires, the display will change back to a single bracket "]" indicating that the oven is no longer baking. No tone will sound when the cook time is complete.

### Exit the Sabbath Mode

Exiting the Sabbath mode should be done after the Sabbath is over.

1. Press **Cancel/Off** to end any bake mode that may be running.
2. Press and hold **Settings** pad until **Sabbath Mode off** is displayed.

### **Sabbath Mode Power Outage Note**

If a power outage occurs while the oven is in Sabbath Mode, the unit will return to Sabbath Mode when power is restored, however the oven will return to the off state even if it was in the middle of a bake cycle when the power outage occurred.

## **CARE AND CLEANING**

### **Cleaning the Range – Exterior**

#### **Control Lockout**

If desired, the touch pads may be deactivated before cleaning.

See Lock Controls in the Oven Controls section in this manual.

Clean up splatters with a damp cloth.

You may also use a glass cleaner.

Remove heavier soil with warm, soapy water. Do not use abrasives of any kind.

Reactivate the touch pads after cleaning.

#### **Control Panel**

It's a good idea to wipe the control panel after each use. Clean with mild soap and water or vinegar and water, rinse with clean water and polish dry with a soft cloth.

Do not use abrasive cleansers, strong liquid cleansers plastic scouring pads or oven cleaners on the control panel—they will damage the finish, Including Black Stainless Steel.

#### **Oven Exterior**

Do not use oven cleaners, abrasive cleansers, strong liquid cleansers, steel wool, plastic scouring pads, or cleaning powders on the interior or exterior of the oven. Clean with a mild soap and water or vinegar and water solution. Rinse with clean water and dry with a soft cloth. When cleaning surfaces, make sure that they are at room temperature and not in direct sunlight.

If stain on the door vent trim is persistent, use a mild abrasive cleaner and a sponge-scrubber for best results.

Spillage of marinades, fruit juices, tomato sauces and basting liquids containing acids may cause discoloration and should be wiped up immediately. Let hot surfaces cool, then clean and rinse.

## **Painted Surfaces and Black Stainless Steel**

Painted surfaces include the sides of the range and the door, top of control panel and the drawer front. Clean these with soap and water or a vinegar and water solution.

Do not use commercial oven cleaners, cleaning powders, steel wool or harsh abrasives on any painted surface, including Black Stainless Steel.

## **Stainless Steel - Excluding Black Stainless Steel (on some models)**

Do not use a steel wool pad; it will scratch the surface.

To clean the stainless steel surface, use warm sudsy water or a stainless steel cleaner or polish. Always wipe the surface in the direction of the grain. Follow the cleaner instructions for cleaning the stainless steel surface.

To inquire about purchasing cleaning products including stainless steel appliance cleaner or polish, see the Accessories and Consumer Support sections at the end of this manual.

## **Cleaning the Range – Interior**

The interior of your new oven can be cleaned manually or by using Steam Clean or Self Clean modes.

Spillage of marinades, fruit juices, tomato sauces and basting liquids containing acids may cause discoloration and should be wiped up immediately. Let hot surfaces cool, then clean and rinse.

### **Manual Cleaning**

Do not use oven cleaners, strong liquid cleansers, steel wool, or scouring pads on the interior of the oven. For soils on the oven bottom and other enameled surfaces, use a gentle abrasive containing oxalic acid, such as Bar Keepers Friend®, with a non-scratch sponge. Take care not to apply any abrasive cleaners or sponges to the door glass, as it will scratch the reflective coating. The oven interior and door glass may be cleaned using a soft cloth with a mild soap and water, or vinegar and water solution. After cleaning, rinse with clean water and dry with a soft cloth.

### **Steam Clean Mode**

The Steam Clean feature is for cleaning light soil from your oven at a lower temperature than Self Clean.

To use the Steam Clean feature:

1. Start with the oven at room temperature.
2. Wipe excess grease and soils from the oven.
3. Pour one cup of water onto the bottom of the oven.
4. Close the door.

5. Press Upper Oven or Lower Oven, press the Clean pad, select Steam Clean and then press Start/Enter.

You cannot open the door during the 30 minute Steam Clean cycle. At the end of the Steam Clean cycle, soak up the remaining water, and wipe the moisture-softened soil from the oven walls and door.

### **Self Clean Mode**

Read Self-Cleaning Oven Safety Instructions at the beginning of this manual before using the Self Clean Mode. Self Clean uses very high temperatures to clean the oven interior. For a moderately soiled oven, run a 3 hour self-clean cycle. For a heavily soiled oven, run a 5 hour self-clean cycle. Only self-clean (black) racks and grates may remain in the oven during the self-clean cycle. All other items, including nickel plated (silver) racks, should be removed. If nickel plated (silver) racks are left in the oven during a self-clean cycle, the racks will tarnish. If either type of rack is left in the oven during a self-clean cycle, the rack may become difficult to slide. See the Oven Racks section for instructions on how to improve.

**IMPORTANT:** The health of some birds is extremely sensitive to the fumes given off during the self-cleaning cycle of any range. Move birds to another wellventilated room.

To use the Self Clean feature:

1. Start with the oven at room temperature.
2. Wipe excess grease and soils from the oven and interior door.
3. Remove all items other than self-clean (black) racks and grates, if desired. See Cleaning the Cooktop to determine if your grates may be selfcleaned and for important details regarding grate placement.
4. Close the door
5. Press Upper Oven or Lower Oven, press the Clean pad, select Self Clean and then press Start/Enter.

You cannot open the door during the self-clean cycle. The door will remain locked after the self-clean cycle until the oven cools below the unlocking temperature. At the end of the self-clean cycle, allow the oven to cool and wipe any ash out of the oven.

### **To Stop a Self-Clean Cycle**

Press the Cancel/Off pad. Wait until the oven has cooled below the locking temperature to unlatch the door. You will not be able to open the door right away unless the oven has cooled below the locking temperature.

### **On Some Models:**

The surface units are automatically disabled during the self-clean cycle. Make sure that all surface unit controls are turned off at all times during the self-clean cycle. Wait until the self-clean cycle is finished to set and use the surface units.

## Racks

All racks can be washed with warm, soapy water. Enameled (not shiny) racks can be left in the cavity during self clean.

Racks may be more difficult to slide, especially after a self-clean. Put some vegetable oil on a soft cloth or paper towel and rub onto the left and right edges.

**NOTE:** Using other cooking oils will cause a discoloring or a rust like color residue on the racks and cavity sides. To clean this residue, use a soap and water or a vinegar and water solution. Rinse with clean water and dry with a soft cloth.

## Oven Heating Elements

Do not clean the bake element or the broil element. Any soil will burn off when the elements are heated.	
----------------------------------------------------------------------------------------------------------	--

The bake element is not exposed and is under the oven floor. Clean the oven floor with warm, soapy water.	
-----------------------------------------------------------------------------------------------------------	--

## Cleaning the Glass Cooktop

### Normal Daily Use Cleaning

ONLY use CERAMA BRYTE® Ceramic Cooktop Cleaner on the glass cooktop. Other creams may not be as effective.

To maintain and protect the surface of your glass cooktop, follow these steps:

1. Before using the cooktop for the first time, clean it with CERAMA BRYTE® Ceramic Cooktop Cleaner. This helps protect the top and makes cleanup easier.
2. Daily use of CERAMA BRYTE® Ceramic Cooktop Cleaner will help keep the cooktop looking new.
3. Shake the cleaning cream well. Apply a few drops of CERAMA BRYTE® Ceramic Cooktop Cleaner directly to the cooktop.
4. Use a paper towel or CERAMA BRYTE® Cleaning Pad for Ceramic Cooktops to clean the entire cooktop surface.
5. Use a dry cloth or paper towel to remove all cleaning residue. No need to rinse.
6. Do not use CERAMA BRYTE® on any metal parts located next to the glass.



Clean your cooktop after each spill. Use CERAMA BRYTE® Ceramic Cooktop Cleaner.

### **Burned-On Residue**

1. Allow the cooktop to cool.
2. Spread a few drops of CERAMA BRYTE® Ceramic Cooktop Cleaner on the entire burned residue area.
3. Using a CERAMA BRYTE® Cleaning Pad for Ceramic Cooktops, rub the residue area, applying pressure as needed.
4. If any residue remains, repeat the steps listed above as needed.
5. For additional protection, after all residue has been removed, polish the entire surface with CERAMA BRYTE® Ceramic Cooktop Cleaner and a paper towel.

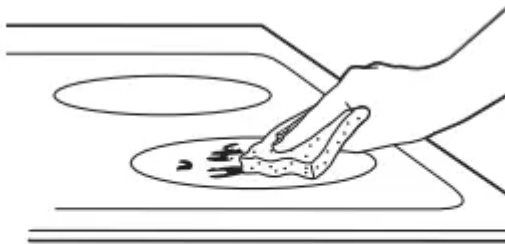

Use a CERAMA BRYTE® Cleaning Pad for Ceramic Cooktops.

### **Heavy, Burned-On Residue**

1. Allow the cooktop to cool.
2. Use a single-edge razor blade scraper at approximately a 45° angle against the glass surface and scrape the soil. It will be necessary to apply pressure to the razor scraper in order to remove the residue.

3. After scraping with the razor scraper, spread a few drops of CERAMA BRYTE® Ceramic Cooktop Cleaner on the entire burned residue area. Use a CERAMA BRYTE® Cleaning Pad to remove any remaining residue.
4. For additional protection, after all residue has been removed, polish the entire surface with CERAMA BRYTE® Ceramic Cooktop Cleaner and a paper towel.

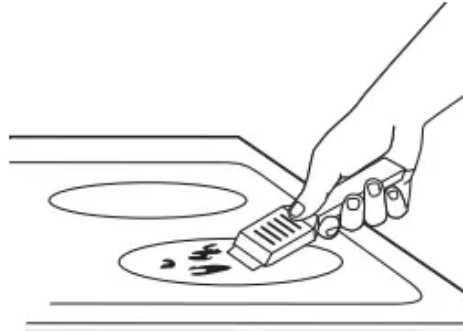

The CERAMA BRYTE® Ceramic Cooktop Scraper and all recommended supplies are available through our Parts Center. See the Accessories and Consumer Support sections at the end of this manual.

**NOTE:** Do not use a dull or nicked blade.

### **Metal Marks and Scratches**

1. Be careful not to slide pots and pans across your cooktop. It will leave metal markings on the cooktop surface.

These marks are removable using the CERAMA BRYTE® Ceramic Cooktop Cleaner with a CERAMA BRYTE® Cleaning Pad for Ceramic Cooktops.

2. If pots with a thin overlay of aluminum or copper are allowed to boil dry, the overlay may leave black discoloration on the cooktop.

This should be removed immediately before heating again or the discoloration may be permanent.

NOTE: Carefully check the bottom of pans for roughness that would scratch the cooktop.

### **Damage from Sugary Spills and Melted Plastic**

Special care should be taken when removing hot substances to avoid permanent damage of the glass surface. Sugary spillovers (such as jellies, fudge, candy, syrups) or melted plastics can cause pitting of the surface of your cooktop (not covered by the warranty) unless the spill is removed while still hot. Special care should be taken when removing hot substances.

Be sure to use a new, sharp razor scraper

Do not use a dull or nicked blade.

1. Turn off all surface units. Remove hot pans.

2. Wearing an oven mitt:

- a. Use a single-edge razor blade scraper to move the spill to a cool area on the cooktop.
- b. Remove the spill with paper towels.

3. Any remaining spillover should be left until the surface of the cooktop has cooled.

4. Don't use the surface units again until all of the residue has been completely removed.

NOTE: If pitting or indentation in the glass surface has already occurred, the cooktop glass will have to be replaced. In this case, service will be necessary.

## Probe

The temperature probe may be cleaned with soap and water or a soap-filled scouring pad. Cool the temperature probe before cleaning. Scour stubborn spots with a soapfilled scouring pad, rinse and dry.

To order additional temperature probes, see the Accessories and Consumer Support sections at the end of this manual.

- Do not immerse the temperature probe in water.
- Do not store the temperature probe in the oven.
- Do not leave the temperature probe Inside the oven during a self or steam clean cycle.



## Oven Light

### Oven Light Replacement

### To remove:

1. Turn the glass cover counterclockwise 1/4 turn until the tabs of the glass cover clear the grooves of the socket. Wearing latex gloves may offer a better grip.
2. Using gloves or a dry cloth, remove the bulb by pulling it straight out.

### To replace:

1. Use a new 120/130-volt halogen bulb, not to exceed 50 watts. Replace the bulb with the same type of bulb that was removed. Be sure the replacement bulb is rated 120 volts or 130 volts (NOT 12 volts).
2. Using gloves or a dry cloth, remove the bulb from its packaging. Do not touch the bulb with bare fingers. Oil from skin will damage the bulb and shorten its life.
3. Push the bulb straight into the receptacle all the way.
4. Place the tabs of the glass cover into the grooves of the socket. Turn the glass cover clockwise 1/4 turn.

For improved lighting inside the oven, clean the glass cover frequently using a wet cloth. This should be done when the oven is completely cool.

5. Reconnect electrical power to the oven.

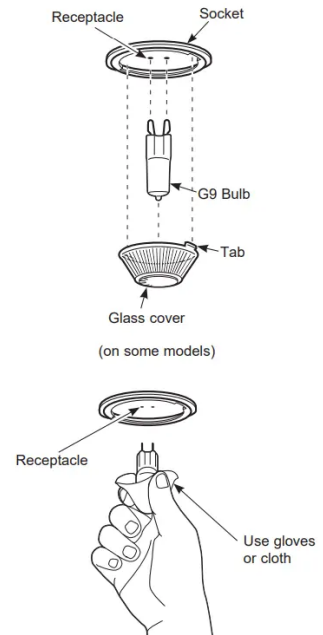

## Oven Doors

### Lift-Off Lower Oven Door

The door is very heavy. Be careful when removing and lifting the door.

Do not lift the door by the handle.

### To remove the door:

1. Fully open the door.
2. Pull the hinge locks down toward the door frame, to the unlocked position. A tool, such as a small flat-blade screwdriver, may be required.
3. Firmly grasp both sides of the door at the top.
4. Close door to the door removal position. The door should be open approximately 3" with no obstruction above the door.
5. Lift door up and out until both hinge arms are clear of the slots.

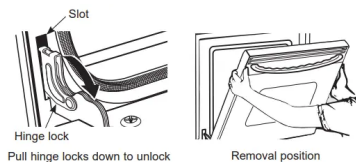

### To replace the door:

1. Firmly grasp both sides of the door at the top.
2. Starting on the left side, with the door at the same angle as the removal position, seat the indentation of the hinge arm into the bottom edge of the hinge slot. The notch in the hinge arm must be fully seated into the bottom of the slot. Repeat for right side.
3. Fully open the door. If the door will not fully open, the indentation is not seated correctly in the bottom edge of the slot.
4. Push the hinge locks up against the front frame of the oven cavity, to the locked position.
5. Close the oven door.

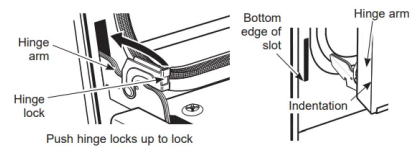

### Lift-Off Upper Oven Door (for double oven)

### To remove the door:

1. Fully open the door.
2. Lift up on the hinge lock toward the oven frame until they stop.
3. Close the door to 45 degrees (you will feel the door stop). The hinge lock will contact the oven frame.
4. On both sides of the door, press down on the release buttons on each hinge.
5. Lift door up until it is clear of the hinge.
6. Pull on hinge arms slightly to relieve pressure on the locking tabs.
7. Push the hinge locks down onto the hinge.
8. Push the hinges in toward the unit so they are closed

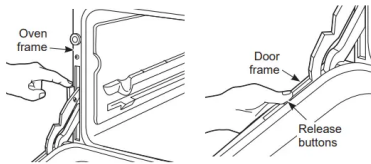

### To replace the door:

1. Pull the hinges down away from the oven frame to the fully open position.
2. Lift up on the hinge locks toward the oven frame until they stop.
3. The hinges will release to the 45-degree position. The hinge locks will contact the oven frame.
4. Slide the door back onto the hinges. Make sure the buttons pop back out.
5. Fully open the door.
6. Push the hinge locks down onto the hinge.
7. Close the oven door.

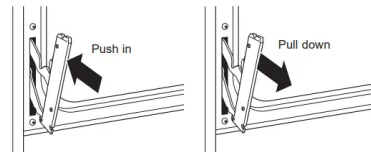

## TROUBLESHOOTING TIPS

<b>Problem</b>	<b>Possible Cause</b>	<b>What To Do</b>
<b>Surface units will not maintain a rolling boil or cooking is not fast enough</b>	<b>Improper cookware being used.</b>	Use pans which are flat and match the diameter of the surface unit selected.
	<b>In some areas, the power (voltage) may be low.</b>	Cover pan with a lid until desired temperature is obtained.
<b>Surface units do not work properly</b>	<b>A fuse in your home may be blown or the circuit breaker tripped.</b>	Replace the fuse or reset the circuit breaker.
	<b>Cooktop controls improperly set.</b>	Check to see the correct control is set for the surface unit you are using.
<b>Surface unit stops glowing when turned to a lower setting</b>	<b>The unit is still on and hot.</b>	This is normal.
<b>Scratches (may appear as cracks) on cooktop glass surface</b>	<b>Incorrect cleaning methods being used.</b>	Scratches are not removable. Tiny scratches will become less visible in time as the surface is cleaned.
	<b>Cookware with rough bottoms being used or coarse particles (salt or sand) were between the cookware and the surface of the cooktop. Cookware has been slid across the cooktop surface.</b>	To avoid scratches, use the recommended cleaning procedures. Make sure both the cooktop and cookware are clean before use, and use cookware with smooth bottoms.
<b>Areas of discoloration on the cooktop</b>	<b>Food spillovers not cleaned before next use.</b>	See the Cleaning the glass cooktop section.
	<b>Hot surface on a model with a light-colored cooktop.</b>	This is normal. The surface may appear discolored when it is hot. This is temporary and will disappear as the glass cools.



<b>Plastic melted to the surface</b>	<b>Hot cooktop came into contact with plastic placed on the hot cooktop.</b>	See the Glass surface—potential permanent damage section in the the glass cooktop section.
<b>Pitting (or indentation) of the cooktop</b>	<b>Hot sugar mixture spilled on the cooktop.</b>	Call a qualified technician for repla
<b>My new oven doesn't cook like my old one. Is something wrong with the temperature settings?</b>	<b>Your new oven has a different cooking system from your old oven and therefore may cook differently than your old oven.</b>	For the first few uses, follow your times and temperatures carefully. think your new oven is too hot or t you can adjust the temperature yo meet your specific cooking prefer <b>NOTE:</b> This adjustment affects Ba Convection Bake temperatures; it affect Convection Roast, Broil or C
<b>Food does not bake properly</b>	<b>Oven controls improperly set.</b>	See the Cooking Modes section.
	<b>Rack position is incorrect or rack is not level.</b>	See the Cooking Modes section a Guide.
	<b>Incorrect cookware or cookware of improper size being used.</b>	See the Cookware section.
	<b>The probe is plugged into the outlet in the oven.</b>	Unplug and remove the probe from
	<b>Oven temperature needs adjustment.</b>	See the Special Features section.
	<b>Ingredient substitution</b>	Substituting ingredients can chang recipe outcome.



<b>Problem</b>	<b>Possible Cause</b>	<b>What To Do</b>
<b>Food does not broil properly</b>	<b>Oven controls improperly set.</b>	Make sure you select the appropriate broil setting.
	<b>Improper rack position being used.</b>	See Cooking Guide for rack location suggestions.
	<b>Food being cooked in a hot pan.</b>	Make sure cookware is cool.
	<b>Cookware not suited for broiling.</b>	Use a pan specifically designed for broiling.
	<b>Aluminum foil used on the broiling pan and grid has not been fitted properly and slit as recommended.</b>	If using aluminum foil conform to pan manufacturer's instructions.
	<b>In some areas the power (voltage) may be low.</b>	Preheat the broil element for 10 minutes.
<b>Oven temperature too hot or too cold</b>	<b>Oven temperature needs adjustment.</b>	See the Special Features section.
<b>Oven does not work or appears not to work</b>	<b>Plug on range is not completely inserted in the electrical outlet.</b>	Make sure electrical plug is plugged into properly grounded outlet.
	<b>A fuse in your home may be blown or the circuit breaker tripped.</b>	Replace the fuse or reset the circuit breaker.
	<b>Oven controls improperly set.</b>	See the Using the Oven section.
	<b>Oven is in Sabbath Mode.</b>	Verify, that the oven is not in Sabbath Mode. See the Special Features section.



<b>“Crackling” or “popping” sound</b>	<b>This is the sound of the metal heating and cooling during both the cooking and cleaning functions.</b>	This is normal.
<b>Why is my range making a “clicking” noise when using my oven?</b>	<b>Your range cycles the heating elements by turning relays on and off to maintain the oven temperature.</b>	This is normal.
<b>Clock and timer do not work</b>	<b>A fuse in your home may be blown or the circuit breaker tripped.</b>	Replace the fuse or reset the circuit breaker.
	<b>Plug on range is not completely inserted in the electrical outlet.</b>	Make sure electrical plug is plugged into properly grounded outlet.
	<b>Oven controls improperly set.</b>	See the Oven Control section.
<b>Oven door is crooked</b>	<b>The door is out of position.</b>	Because the oven door is removable, it gets out of position during installation. To straighten the door, re-install the door. See the “Lift-Off Oven Door” instruction in the “Care and Cleaning” section.
<b>Oven light does not work</b>	<b>Light bulb is loose or defective.</b>	Tighten or replace bulb.
	<b>Pad operating light is broken.</b>	Call for service.
<b>Oven will not self-clean</b>	<b>The temperature is too high to set a selfclean operation.</b>	Allow the oven to cool and reset the controls.
	<b>Oven controls improperly set.</b>	See the Cleaning the Oven section.
	<b>The probe is plugged into the outlet in the oven.</b>	Remove the probe from the oven.



<b>Oven will not steam clean.</b>	<b>Display flashes HOT.</b>	Allow the oven to cool to room temperature and then reset the controls.
	<b>Oven controls improperly set.</b>	See the Using Steam Clean section.
	<b>Oven door is not closed.</b>	Make sure you close the door to start steam clean cycle.
<b>Excessive smoking during clean cycle</b>	<b>Excessive soil or grease.</b>	Press the <b>Cancel/Off</b> pad. Open the oven door to rid the room of smoke. Wait until the <b>LO</b> display goes off. Wipe up the excess soil and grease. Restart clean cycle.



<b>Problem</b>	<b>Possible Cause</b>	<b>What To Do</b>
<b>Excessive smoking during broiling</b>	Food too close to broil element.	Lower the rack position of the food.
<b>Oven door will not open after a clean cycle</b>	Oven too hot.	Allow the oven to cool below locking temperature.
<b>Oven not clean after a clean cycle</b>	Oven controls improperly set.	See the Cleaning the Oven section.
	Oven was heavily soiled.	Clean up heavy spillovers before starting cycle. Heavily soiled ovens may need to be cleaned again or for a longer period of time.
<b>"DOOR LOCKING" flashes in the display</b>	The self-clean cycle has been selected but the door is not closed.	Close the oven door. Latch the door.
<b>DOOR LOCKED is on when you want to cook</b>	The oven door is locked because the temperature inside the oven has not dropped below the locking temperature.	Press the <b>Cancel/Off</b> pad. Allow the oven to cool.
<b>"F— and a number or letter" flash in the display</b>	You have a function error code.	Press the <b>Cancel/Off</b> pad. Allow the oven to cool for one hour. Put the oven back into operation.
	If the function code repeats.	Disconnect all power to the oven for at least 30 seconds and then reconnect power. If the error code repeats, call for service.
<b>Display goes blank</b>	A fuse in your home may be blown or the circuit breaker tripped.	Replace the fuse or reset the circuit breaker.
	The clock is turned off.	See the Special features section.



	Oven is in Sabbath Mode.	Verify that the oven is not in Sabbath Mode. See the Special Features section.
<b>Oven or cooktop will not stay set.</b>	Function error.	Disconnect all power for at least 30 seconds, then reconnect power. If repeating, call for service.
<b>Power outage, clock flashes</b>	Power outage or surge	Reset the clock. If the oven was in use, you may need to reset it by pressing the <b>Cancel/Off</b> pad, setting the clock and resetting any cooking functions.
<b>“Burning” or “oily” odor emitting from the vent</b>	This is normal in a new oven and will disappear in time.	To speed the process, set a self-clean cycle for a minimum of 3 hours. See the Cleaning the Oven section.
<b>Strong odor</b>	An odor from the insulation around the inside of the oven is normal for the first few times the oven is used.	This is temporary and will go away after several uses or a selfclean cycle.
<b>Fan noise</b>	A convection fan may automatically turn on and off.	This is normal. The fan is designed to operate intermittently to maximize cooking evenness. The convection fan will operate during preheat and the bake cycle. The fan will turn off after the oven is heated to the set temperature. This is normal.
	A cooling fan may automatically turn on and off.	This is normal on some models. The cooling fan will turn off and on to cool internal parts. It may turn on when the oven is turned off.
<b>My oven door glass appears to be "tinted" or have a "rainbow" color. Is this defective?</b>	No. The inner oven glass is coated with a heat barrier to reflect the heat back into the oven to prevent heat loss and keep the outer door cool while baking.	This is normal. Under certain light or angles, you may see this tint or rainbow color.



<b>Sometimes the oven takes longer to preheat to the same temperature</b>	Cookware or food in oven.	The cookware or food in the oven will cause the oven to take longer to preheat. Remove the cookware or food and reduce preheat time.
	Number of racks in oven.	Adding more racks to the oven will cause the oven to take longer to preheat. Remove some racks.
	Different cooking modes.	The different cooking modes use different methods to heat the oven for the specific mode. Some modes will take longer than others (e.g., convection bake).
<b>Display flashes</b>	Power failure.	Reset the clock.



<b>Problem</b>	<b>Possible Cause</b>	<b>What To Do</b>
<b>Unable to set cook time or delay time</b>	You forgot to enter a cooking mode first.	See the Options section
<b>Oven racks are difficult to slide</b>	The shiny, silver-colored racks were cleaned in a self-clean cycle.	Apply a small amount of vegetable oil to a paper towel and wipe the edges of the oven racks with the paper towel. Do not spray with Pam or other lubricant sprays.
<b>Drawer does not slide smoothly or drags</b>	The drawer is out of alignment.	Fully extend the drawer and push it all the way in. See the Care and cleaning of the range section.
	Drawer is over-loaded or load is unbalanced.	Reduce weight. Redistribute drawer contents.
<b>Steam from the vent</b>	When using the ovens, it is normal to see steam coming out of the oven vents. As the number of racks or amount of food being cooked increases, the amount of visible steam will increase.	This is normal.
<b>Water remaining on oven floor after Steam Clean cycle</b>	This is normal.	Remove any remaining water with a dry paper towel or sponge.
<b>Oven will not steam clean</b>	Display flashes HOT.	Allow the oven to cool to room temperature and then reset the controls.
	Oven controls improperly set.	See the Using Steam Clean section.
	Oven door is not closed.	Make sure you close the door to start steam clean cycle.



<b>Display prompts for Probe Temperature</b>	This is reminding you to enter a probe temperature after plugging in the probe.	Enter a probe temperature.
----------------------------------------------	---------------------------------------------------------------------------------	----------------------------

### **Warning**

This content is compiled from multiple sources and is provided for reference purposes only. It may not be complete or fully applicable to all situations. If you are unable to resolve your issue, please contact the product manufacturer or an authorized service provider for official support.