

Installation

Refrigerator at a glance

The actual appearance of your refrigerator may differ, depending on the model and the country

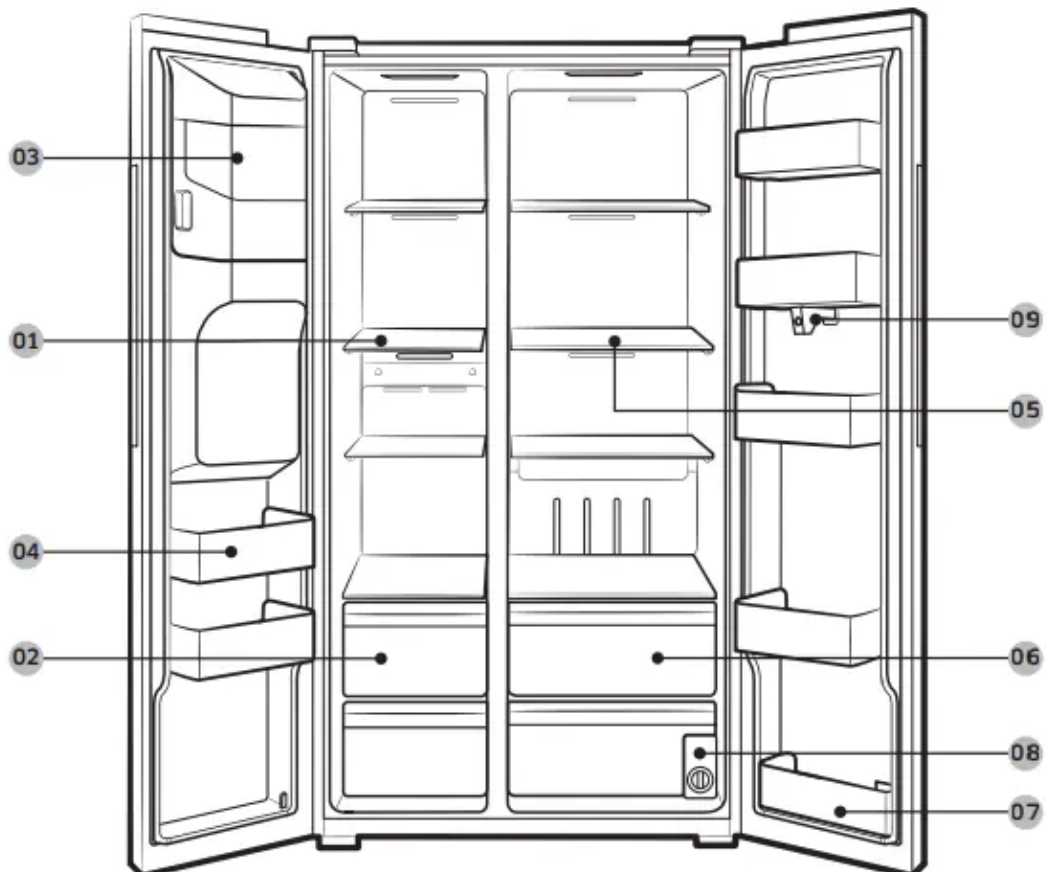

- 01. Freezer shelves
- 02. Freezer drawer
- 03. Ice maker bucket
- 04. Freezer door bin
- 05. Fridge shelves
- 06. Fridge drawer
- 07. Fridge door bin
- 08. Water filter
- 09. Inner-view camera

NOTE The design of the egg container may differ with the model.

Operations

User interface

NOTE

- For more information about other menus and apps available on the Refrigerator app. See the Online manual of your refrigerator.
- The content of apps and widgets, or their design is subject to change or support may be discontinued without notice, depending on the content provider's policy.
- Children's use of the refrigerator's functions, apps, and services must be supervised by adults.
- Underage transactions with the services must be supervised by adults

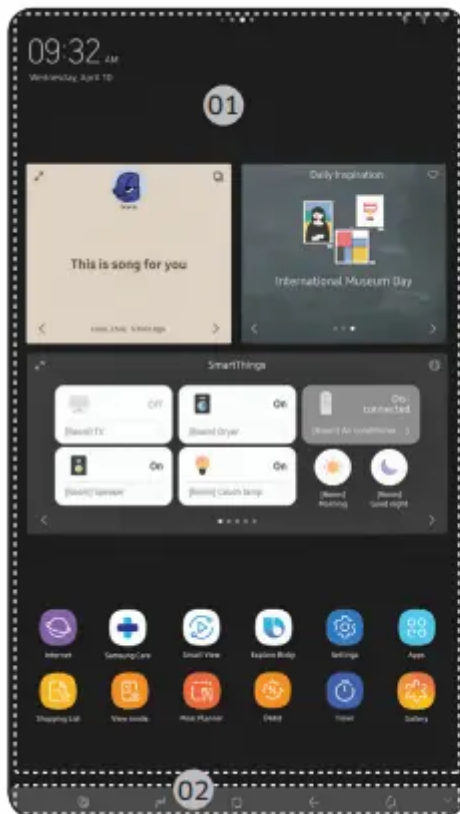

01 Home screen
02 Soft buttons

01 Home screen









01 Apps & Widgets

- Tap a desired app or widget to launch it.
- Tap and hold an app or widget to enter Edit mode. A grid appears. In Edit mode, you can drag and drop an app or widget to a new position on the grid. When you move the app or widget to a new grid location, the location turns grey if it is available. If it is not available, it turns red.
- You can add an app or widget that has been removed from the Apps list.

02 Status bar

- Displays the status of various functions. (Refer to the following Icon descriptions table.)

Icon descriptions

Bluetooth ()	Indicates Bluetooth connection status.
USB ()	Indicates USB connection status. NOTE The refrigerator supports USB memory that is formatted in the FAT32 or exFAT file systems. NTFS is not supported. Be sure to convert NTFS to FAT32 or exFAT before use.
Remote Management ()	Turns on when Remote Management is enabled and running.
Network ()	Indicates network connection status in 5 levels (Off, 1-4).
Software Update ()	Indicates the newest version of software has been downloaded from the server and is ready to update.
Notification ()	Indicates there is a notification message.
Cloud sync ()	Indicates Family Hub is receiving data from the cloud server.

02 Soft buttons

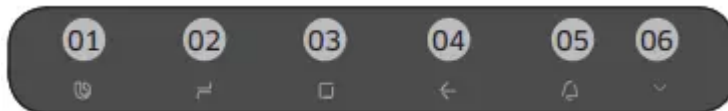

01 Bixby

- Tap to use Bixby.

02 Task Manager

- Tap to open the Task Manager.
- See the Task Manager section for details.

03 Home

- Tap to open the Home screen.

04 Return

- Tap to return to the previous screen.

05 Notification

- Tap to display the Quick Panel.

06 Hide/Show

- Tap to hide or show Soft buttons.
- The Hide/Show button only appears when an app is active.

Fridge Manager

To access Fridge Manager, swipe the Home screen to the left, and then tap the Fridge Manager widget.



- Tap < or > on the bottom of the widget to move between pages.
- On the first page, you can check the current temperatures or modes of each compartment as well as active special functions.
- Tap the first page to open the Fridge Manager for detailed settings.
- On the second page, you can check the filter status.
- Tap the second page to open the Fridge Settings.
- Tap Buy Filter on the second page to open the website where you can purchase a water filter.



The Fridge Manager is a graphical representation of your refrigerator. The left half represents the freezer compartment, the right half represents the refrigerator compartment. The temperature or mode settings for each are displayed over each section.

Fridge Manager At a Glance

01 Temperature

Set or change the temperatures for the fridge and freezer with Power mode (Power Cool or Power Freeze).

- Power Cool and Power Freeze speeds up the cooling and freezing process at maximum fan speed. The fridge and the freezer keeps running at full speed for several hours, and then returns to the previous temperature.
- To freeze large amounts of food, activate Power Freeze for at least 20 hours before putting food in the freezer.

NOTE Using Power Cool or Power Freeze increases power consumption. Make sure you turn it off to return to the previous temperature if you do not intend to use it.

02 Special Features

Special functions available on this refrigerator are listed with a brief description.

03 Fridge Settings

See the next page for details.

04 External Conditions

Displays the external (ambient) temperature and humidity.

NOTE The displayed conditions may differ from the actual temperature and humidity.

NOTE Also displayed is the Ice Off (ice making off) indicator at the top, center. When the indicator displays Ice Off, the refrigerator's ice maker is turned off.

Ice Maker	<p>Turns the icemaker on and off. Tap and drag the button to turn on or off. Note that if the ice bucket is full of ice, the refrigerator does not start making ice when you tap and drag this button (turning the Ice Maker on), but displays the Ice Full indicator on the main screen.</p> <p>If you hold down the dispenser lever for 5 seconds, the Ice Maker Off status changes to Ice Maker On.</p>
Dispenser Lock	<p>Turns the ice and water dispensers on and off. Tap to set Dispenser Lock on or off.</p>
Door Alarm	<p>The door alarm sounds if you leave the door open. Tap and drag the button to turn on or off.</p>
Temp. Unit	<p>Switch the temperature scale between Celsius and Fahrenheit. Touch °F or °C to change the scale.</p>
Water Filter	<p>Provides a water filter replacement tutorial and lets you reset the water filter replacement indicator. Tap to open.</p> <p>NOTE</p> <ul style="list-style-type: none"> • After installing the water filter, tap Water Filter, and then tap Reset. Tapping Reset re-initializes the function that measures the time remaining until the water filter needs to be replaced again. • If you tap the Buy Filter, you will be directed to the website where you can purchase a water filter.
Self Check	<p>Self Check is a self diagnoses function. Tap to open. Tap Start to run.</p>
Demand Response (applicable models only)	<p>Works with the Smart Grid energy saving manager. Tap to open. Tap and drag the button to turn on or off. See the Smart Grid section in this manual for more information.</p>
Cooling Off	<p>Cooling Off mode (also called Shop mode), is designed for use by retailers when they are displaying refrigerators on the shop floor. In Cooling Off mode, the refrigerator's fan motor and lights work normally, but the compressors do not run, and the refrigerator and freezer do not get cold. If Cooling Off is turned on, all cooling controls will turn to OFF on the Fridge Manager.</p>

- To activate Cooling Off, tap Activate > Proceed from Cancel/ Proceed.
- To deactivate Cooling Off, tap Deactivate > Proceed from Cancel/ Proceed.

Connections	Wi-Fi	<ul style="list-style-type: none"> • Turn on or turn off a Wi-Fi connection. The current Wi-Fi network is listed first in the access point (AP) list.
	Network Status	<ul style="list-style-type: none"> • You can check your Network Status by Selection of Network Status Menu.
	Bluetooth and Speaker	<ul style="list-style-type: none"> • When the Speaker mode is on, you can listen to music and media on your mobile phone or tablet through Family Hub's speaker. - Only one connected mobile phone or tablet is listed. • When the Speaker mode is off, you can search and connect to nearby Bluetooth-enabled devices. - Up to 4 recently paired Bluetooth devices are listed. - To add a new device when 4 paired devices are listed, first unpair a paired device from the device list. - Available devices are Bluetooth-enabled headsets, headphones, and speakers.
	Easy Connection	<ul style="list-style-type: none"> • Easy Connection can be used with Samsung Smartphone apps, and allows you to connect your device to the same home Wi-Fi network that your smartphone is connected to.
Display	Display	<ul style="list-style-type: none"> • You can set the screen brightness, wallpapers, auto wake-up, theme, screen timeout, and duration of the screen saver.
	Clean screen mode	<ul style="list-style-type: none"> • Turn on so you can clean the screen without activating any apps.
Sound		<ul style="list-style-type: none"> • Set the volume and equalizer and turn on or turn off the touch sound.
Notifications		<ul style="list-style-type: none"> • You can turn on or turn off Preview of Notification.
Profile		<ul style="list-style-type: none"> • You can add, edit, or delete a profile.

Bixby		<ul style="list-style-type: none"> • You can set the function that related with voice recognition. • Language and Voice Style : Set the language to communicate with Bixby and set the style of voice feedback. The selected language is applied only when you talk with Bixby. • Sound feedback : Change the sound feedback settings. • Voice wake-up : Set Bixby to wake up when it hears you say “Hi, Bixby”. You can also change the settings for the voice wake-up feature. • Voice ID : Change the Voice ID settings. You can also register and delete the Voice ID. • Privacy : Set to use Bixby’s interactive and customised services to enhance your experience. • About Bixby : View the Bixby version and legal information.
Security		<ul style="list-style-type: none"> • Enable or disable restrictions on Family Hub features and apps.
Storage		<ul style="list-style-type: none"> • You can check saving storage of each app and check saving storage of Images.
Language and Time	Language	<ul style="list-style-type: none"> • Select a preferred language. Available languages depend on the sales region.
	Date and Time	<ul style="list-style-type: none"> • Make sure the Auto update function is on with a proper Wi-Fi network connection. Open the fridge door and locate the display reset button on the inner side of the door. Press the button and press again to reset the display. Then, the date and time will be synced by the time server. • You can change the time zone through the Time zone menu.
About Family Hub	Device information	<ul style="list-style-type: none"> • Make sure the Software Update function is on with a proper Wi-Fi network connection.

		<ul style="list-style-type: none"> • When updates are available, the Update button becomes active. When updates are complete, the refrigerator restarts automatically. • Legal information displays the Open Source License Agreement. Tap the list item to open the Open Source Announcement.
	Restart and Factory Data Reset	<ul style="list-style-type: none"> • You can restart Family Hub LCD by selection of Restart Button. • You can initialize Setting of Wi-Fi and Bluetooth by selection of Reset network Settings Button. • Tap Reset to restart the refrigerator by selection of Factory Data Reset button. All user data will be removed permanently. Data that will be removed includes account information, memos, photos, and user settings. <p>CAUTION Once factory reset is complete, no user data can be recovered.</p>
Help & Contact Us	Online Manual	<ul style="list-style-type: none"> • The online manual will walk you through various menus and apps that the refrigerator provides directly on the display.
	Remote Management	<ul style="list-style-type: none"> • Use Remote Management to allow a service representative to remotely diagnose problems and provide solutions. • Remote Management requires a Wi-Fi connection. • The Remote Management menu does not appear on models that do not support Remote Management.

SmartThings

Installation

Visit the Google Play Store, Galaxy Apps, or Apple App Store and search for “SmartThings”. Download and install the SmartThings app provided by Samsung Electronics to your smart device.

NOTE

- The SmartThings app is not available for some tablet and iPad and some smartphone.
 - Support that [Android] OS 6.0 or higher. (mimimum 2 GB RAM Size)
 - Support that [iOS] 10.0 or higher/iPhone 6 or higher.
- For improved performance, the SmartThings app is subject to change without notice or discontinued support according to the manufacturer's policy.
- Recommended encryption systems include WPA/TKIP and WPA2/AES. Any newer or non-standard Wi-Fi authentication protocols are not supported.
- Wireless networks may be affected by the surrounding wireless communication environment.
- If your Internet service provider has registered the MAC address of your PC or modem for identification, your Samsung Smart Refrigerator may fail to connect to the Internet. If this happens, contact your Internet service provider for technical assistance.
- The firewall settings of your network system may prevent your Samsung Smart Refrigerator from accessing the Internet. Contact your Internet service provider for technical assistance. If this symptom continues, contact a local Samsung service center or retailer.
- To configure the wireless access point (AP) settings, see the user manual of the AP (router).
- Samsung Smart Refrigerators support both IEEE 802.11 b/g/n (2.4 GHz) and 802.11 a/n/ac (5 GHz) protocols. (IEEE 802.11 n and 802.11 ac are recommended.)
- Unauthorized Wi-Fi wireless routers may fail to connect to applicable Samsung Smart Refrigerators.

Samsung account

You are required to register your Samsung account to use the app. If you don't have a Samsung account, follow the app's onscreen instructions to create a free Samsung account.

Getting started

Turn on the device you want to connect, open the SmartThings app on your phone, and then follow the instructions below.

If a pop-up appears saying that a new device has been found, tap ADD NOW.

If a pop-up doesn't appear, tap the + button, and then select the device you want to connect from the list of available devices.

If your device isn't in the list of available devices, tap Supported Devices, select the device type (Refrigerator), and then select the specific device model.

Follow the instructions in the app to set up your device. Once setup is complete, your refrigerator will appear as a "card" on your Devices screen.

Refrigerator app

Integrated control You can monitor and control your refrigerator at home and on the go.

- Tap the refrigerator icon on the SmartThings Dashboard or tap the Devices icon at the bottom of the Dashboard, and then tap the refrigerator "card" to open the Refrigerator page.
- Check the operation status or notifications related to your refrigerator, and then change options or settings if necessary.

NOTE Some options or settings of the refrigerator may not be available for remote control.

Refrigerator settings

Category	Item	Description
Monitoring	Fridge temperature	Displays the desired temperature setting of the fridge.
	Freezer temperature	Displays the current temperature of the freezer.
	Diagnosis	Detects abnormal operations of the refrigerator.
	Energy monitoring	Checks the accumulated power consumption of the refrigerator for the last 180 days.
Functions	Ice making	You can turn the ice making function on or off, and check the current settings of the function.
		You can also check the status and progress of ice making.
	Power Cool	You can turn Power Cool on or off, and check the current settings.
	Power Freeze	You can turn Power Freeze on or off, and check the current settings.
	Fridge temperature	You can set the desired temperature of the fridge.
	Freezer temperature	You can set the desired temperature of the freezer.



Alarms	Abnormally high temperature	This alarm is triggered when the fridge or the freezer has abnormally high temperatures.
	Door opening	This alarm is triggered if the fridge door or the freezer drawer is open for a specific time.
	Water filter replacement	This alarm reminds you that the water filter must be replaced.
Inside Image		You can view the inside of the refrigerator and can see if you need to replace food items.
Family Hub App Link		You can connect to the App Store and download the Refrigerator app.

Recommendations for voice recognition

For the voice recognition function, there is a built-in microphone at the top of the refrigerator's display. To use the voice recognition function:

- Stand no more than 3 feet (1 meter) from the refrigerator and speak loudly and clearly towards the built-in microphone.
- Speak at a regular pace. Reduce ambient noises, such as noises from a living-room TV.

NOTE The voice recognition function may not work if you stand more than 3 feet (1 meter) away or if you speak too softly

Dispenser panel (applicable models only)

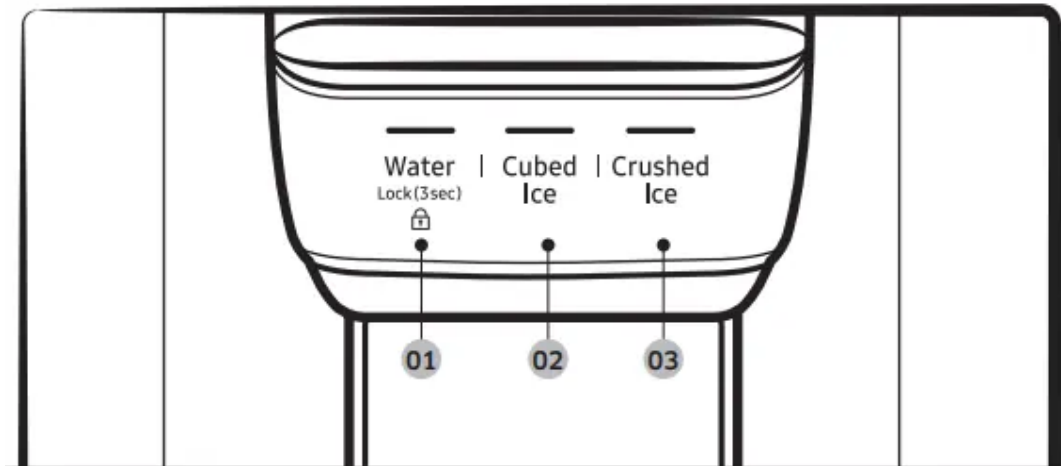

01 Water / Lock

02 Cubed Ice

03 Crushed Ice

01 Water / Lock (3 sec)

Water	To dispense chilled water, press Water. The corresponding indicator turns on.
Lock (Dispenser panel / Dispenser lever)	<p>To prevent the use of the dispenser panel buttons and the dispenser lever, press and hold Water for more than 3 seconds. If you press and hold the button again for more than 3 seconds, the dispenser lock will be deactivated.</p> <p>When dispenser lock is on, the indicator blinks if any button on the dispenser panel is pressed or the dispenser lever is pressed.</p> <p>NOTE The Lock on the dispenser panel does not affect the controls on the main panel. To lock the main panel, use the Lock function on the main panel.</p>

02 Cubed Ice

Cubed Ice	Press Cubed Ice to dispense cubed ice. The corresponding indicator turns on.
-----------	--

03 Crushed Ice

Crushed Ice	Press Crushed Ice to dispense crushed ice. The corresponding indicator turns on.
-------------	--

Special features

Water/Ice dispenser

Using the dispenser, you can dispense water with or without ice.

The water dispenser offers 3 options: chilled water, cubed ice, and crushed ice. To dispense chilled water, press Water on the dispenser panel. Put a water glass under the dispenser, and then push the dispenser lever.

To dispense water with ice

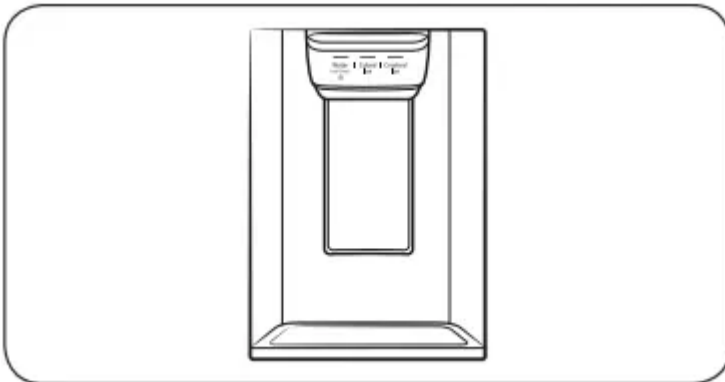

1. With the Ice Maker enabled, press Cubed Ice or Crushed Ice to select the ice type.
2. Put a water glass under the dispenser, and then push the dispenser lever with the glass. Ice will be dispensed from the dispenser.
3. Press Water to select water.
4. Push the dispenser lever with the glass. Water will be dispensed from the dispenser.

NOTE

- The dispenser will stop dispensing if you keep pushing the dispenser lever for about 1 minute. To dispense more water, release and push the lever again.
- Make sure the glass is in line with the dispenser to prevent the dispensed water from spilling out.
- If you do not use the water dispenser for 2-3 days, the dispensed water may have an abnormal smell or taste. This is not a system failure. Discard the first 1-2 glasses of water.

Auto ice maker

The refrigerator has a built-in ice maker that automatically dispenses ice so that you can enjoy filtered water with cubed or crushed ice.

Ice making

After you have installed your refrigerator and plugged it in, follow these instructions to ensure proper ice making and to keep the ice bucket full of ice:

1. Let the refrigerator operate for at least 24 hours to ensure optimal performance.
2. Dispense the first 4 to 6 ice cubes into a glass.
3. Wait another 8 hours and dispense another 4 to 6 ice cubes.
4. Then, wait another 16 hours and dispense the first glass-full of ice.

NOTE

- If you consume all the ice at once, you must wait 8 hours before dispensing the first 4 to 6 cubes. This ensures that the ice bucket is filled with ice properly.
- Ice cubes generated rapidly may look white, which is normal.

Diagnosis

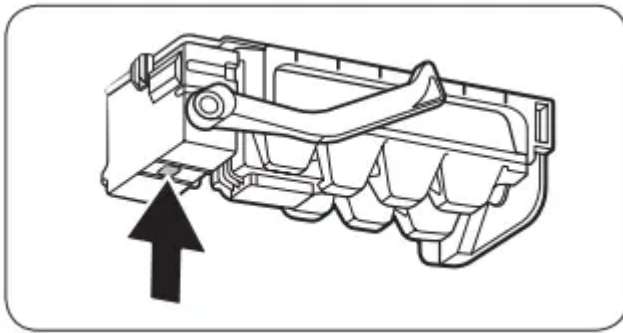

If ice does not dispense, first check the ice maker.

1. Press Test on the bottom of the ice maker. You will hear a chime (ding-dong) when you press the button.
2. You will hear another chime if the ice maker is operating properly.

Maintenance

Handle and care

Icemaker bucket

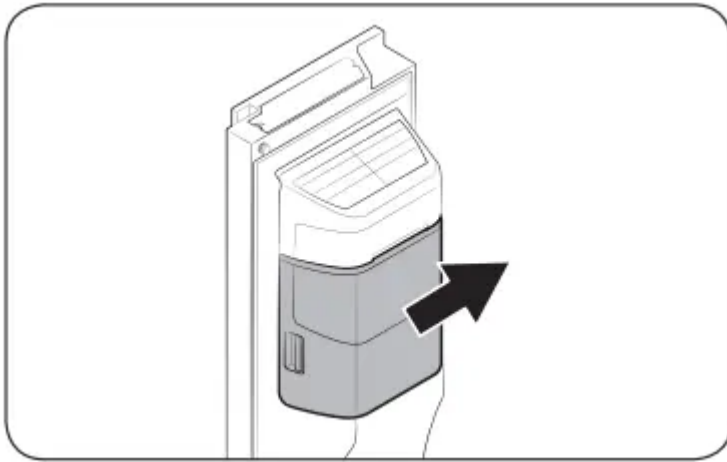

If you do not dispense ice for an extended period, ice may form clumps inside the bucket. If this happens, remove and empty the icemaker bucket.

1. To remove the icemaker bucket, gently lift it up and pull out slowly while holding the handgrips with both hands.
2. Remove and empty the icemaker bucket.

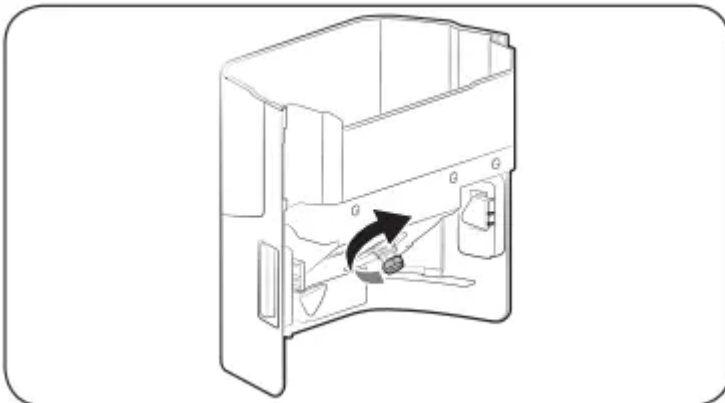

3. When done, turn the gear handle on the rear of the bucket by 90°, and then put the bucket back into position. Make sure the bucket is inserted properly until you hear a clicking sound.
4. Press and hold Ice Maker for 3 seconds to reset the ice maker.

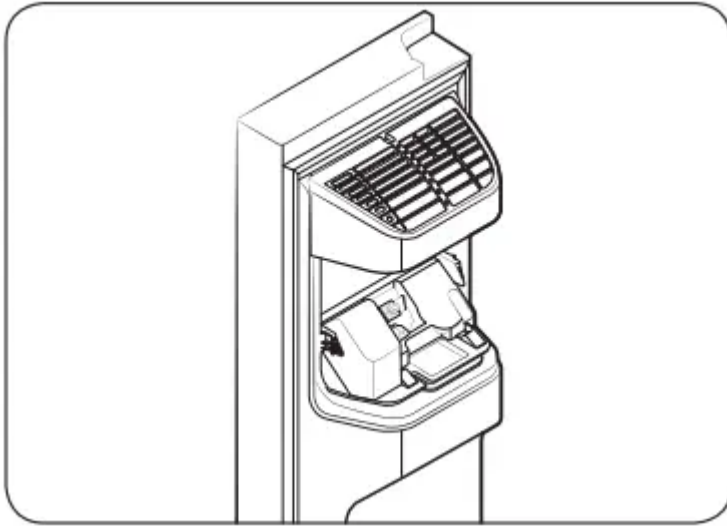

CAUTION

- Do not apply excessive force to the bucket cover. The cover may break.
- Do not close the door hard. Water may spill over the ice maker.
- To prevent injury, make sure to clean up any ice or water that has fallen on the floor.
- To prevent accidents or injury, do not let children play with the water dispenser or the ice maker.
- Do not put your hand or an object into the ice chute. This may cause physical injury or product damage.

NOTE

- Any sound from the ice maker is normal, which outputs during the ice making process.
- While the door is open, neither the ice maker nor the water dispenser operates.

Shelves (fridge/freezer)

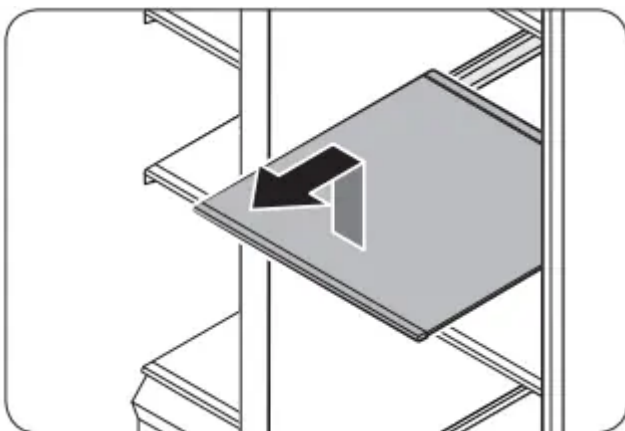

Pull the shelf out as far as it goes. Then lift it up and remove it.

Door bins

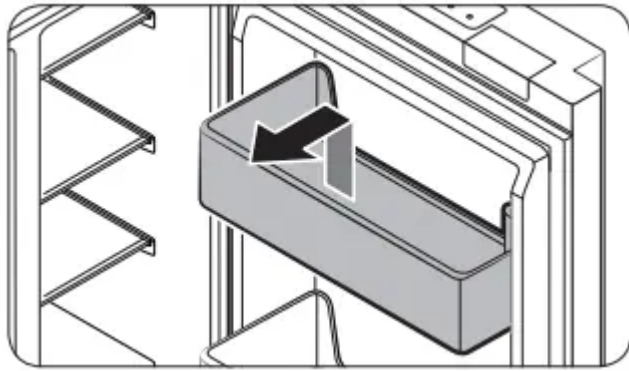

To remove a door bins, hold the front sides of the bin and gently lift up to remove.

Drawers

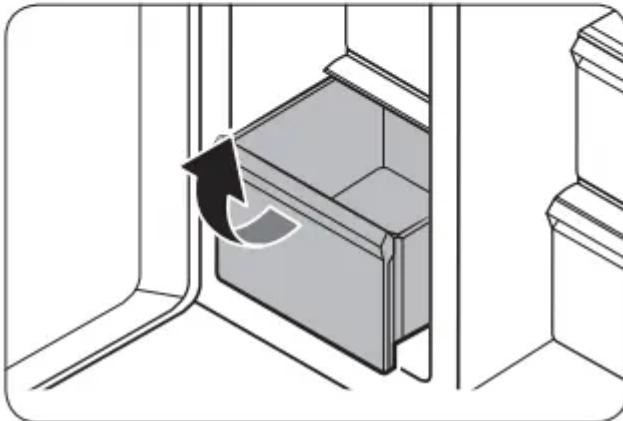
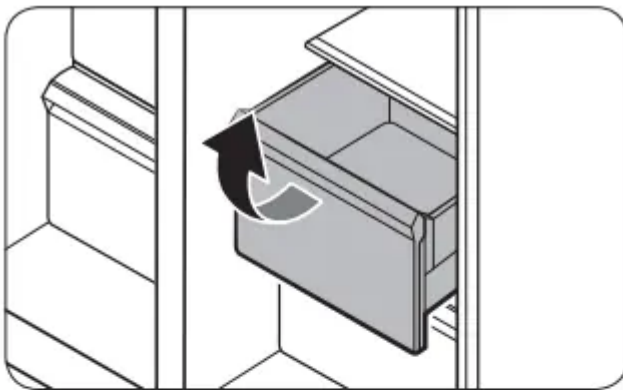

To remove, pull the drawers out as far as they go, and then lift up slightly and pull.

Drawer cover

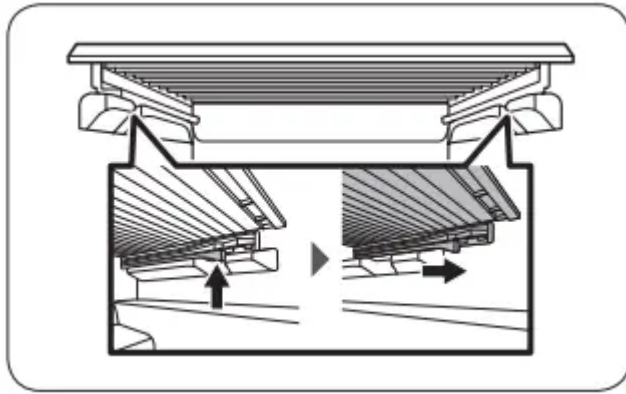

While pushing the left and right hooks underneath the drawer cover, pull the drawer cover to remove.

Cleaning

Interior and exterior

WARNING

- Do not use benzene, thinner, or home/car detergent such as Clorox™ for cleaning purposes. They may damage the surface of the refrigerator and cause a fire.
- Do not spray water onto the refrigerator. This may cause electric shock.

Regularly use a dry cloth to remove all foreign substances such as dust or water from the power plug terminals and contact points.

1. Unplug the power cord.
2. Use a moistened, soft, lint-free cloth or paper towel to clean the refrigerator's interior and exterior.
3. When done, use a dry cloth or paper towel to dry well.
4. Plug in the power cord.

Inner-view camera

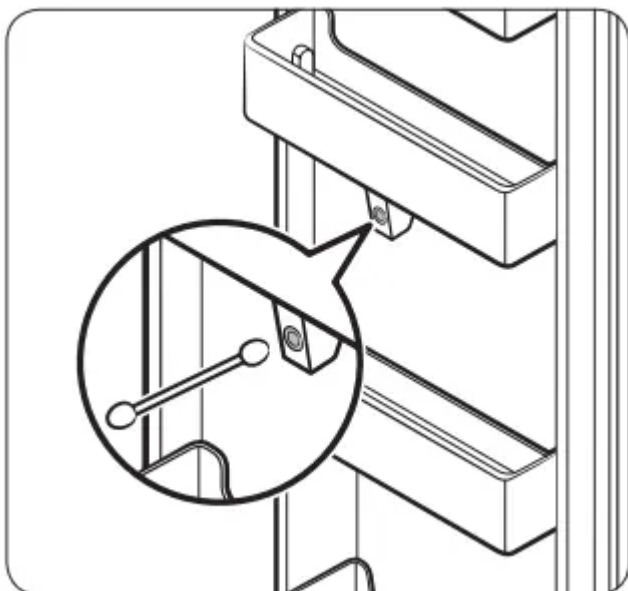

NOTE Use a cotton swab or microfiber cloth to clean the camera on the left-side door of the fridge.

Ice / Water dispenser

CAUTION When crushed ice is selected, some residual ice chips may collect in the ice chute. To prevent this, remove the residual ice from the chute using a soft, clean cloth.

Rubber seals

If the rubber seals of a door become dirty, the door may not close properly and reducing refrigerator performance and efficiency. Use a mild detergent and damp cloth to clean the rubber seals. Then, dry well with a cloth.

Rear panel

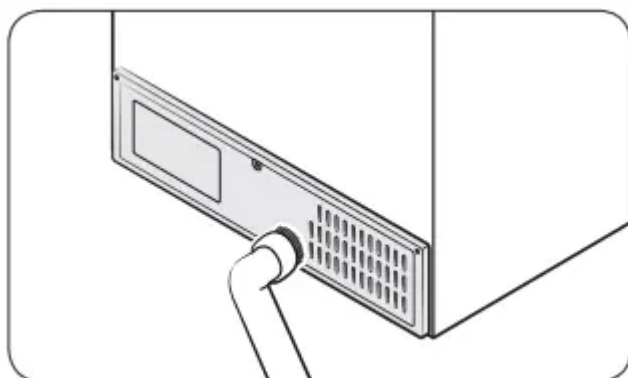

To keep cords and exposed parts of the rear panel free of dirt, vacuum the panel once or twice a year.

CAUTION Do not remove the rear panel cover. Electric shock may occur.

Troubleshooting

Before calling for service, review the checkpoints below. Any service calls regarding normal situations (No Defect Cases) will be charged to users.

General

Temperature

Symptom	Possible causes	Solution
Fridge/ freezer does not operate. Fridge/freezer temperature is warm.	<ul style="list-style-type: none"> • Power cord is not plugged in properly. 	<ul style="list-style-type: none"> • Properly plug in the power cord.
	<ul style="list-style-type: none"> • Temperature control is not set correctly. 	<ul style="list-style-type: none"> • Set the temperature lower.
	<ul style="list-style-type: none"> • Refrigerator is located near a heat source or direct sunlight. 	<ul style="list-style-type: none"> • Keep the refrigerator away from direct sunlight or a heat source.
	<ul style="list-style-type: none"> • Not enough clearance between refrigerator and nearby walls or cabinets. 	<ul style="list-style-type: none"> • We recommend that the gap between the refrigerator and nearby walls (or cabinets) is more than 2" (50 mm).
	<ul style="list-style-type: none"> • The refrigerator is overloaded. Food is blocking the refrigerator vents. 	<ul style="list-style-type: none"> • Do not overload the refrigerator. Do not allow food to block vents.
Fridge/freezer is over-cooling.	<ul style="list-style-type: none"> • Temperature control is not set correctly. 	<ul style="list-style-type: none"> • Set the temperature higher.
Interior wall is hot.	<ul style="list-style-type: none"> • Refrigerator has heat-proof piping in the interior wall. 	<ul style="list-style-type: none"> • To prevent condensation from forming, the refrigerator has heat-proof piping in the front corners. If the ambient temperature rises, this equipment may not work effectively. This is not a system failure. 

Odour

Symptom	Possible causes	Solution
Refrigerator has odours.	• Spoiled food.	• Clean the refrigerator and remove any spoiled food.
	• Food with strong odours.	• Make sure strong smelling food is wrapped airtight.

Frost

Symptom	Possible causes	Solution
Frost around the vents.	• Food is blocking the vents.	• Make sure no food blocks the refrigerator vents.
Frost on interior walls.	• Door is not closed properly.	• Make sure food does not block the door. Clean the door gasket.

Condensation

Symptom	Possible causes	Solution
Condensation forms on the interior walls.	• If door is left open, moisture enters the refrigerator.	• Remove the moisture and do not leave a door open for extended periods of time.
	• Food with high moisture content.	• Make sure food is wrapped airtight.

Water/ice (dispenser models only)

Symptom	Possible causes	Solution
Water flow is weaker than normal.	<ul style="list-style-type: none"> • Water pressure is too low. 	<ul style="list-style-type: none"> • Make sure the water pressure is between 20 to 120 psi.
Ice maker makes a buzzing sound.	<ul style="list-style-type: none"> • The ice maker function is activated, but the water supply to the refrigerator has not been connected. 	<ul style="list-style-type: none"> • Activate the Ice Maker off.
Ice maker does not make ice.	<ul style="list-style-type: none"> • Ice maker has just been installed. 	<ul style="list-style-type: none"> • You must wait for 12 hours for the refrigerator to make ice.
	<ul style="list-style-type: none"> • Freezer temperature is too high. 	<ul style="list-style-type: none"> • Set the freezer temperature below 0 °F (-18 °C) or -4 °F (-20 °C) in warm ambient air.
	<ul style="list-style-type: none"> • Dispenser Lock is activated. 	<ul style="list-style-type: none"> • Deactivate dispenser Lock.
	<ul style="list-style-type: none"> • Ice maker is off. 	<ul style="list-style-type: none"> • Turn on the ice maker.
Ice does not dispense.	<ul style="list-style-type: none"> • Ice may jam if the ice dispenser is not used for a long time (approx. 3 weeks). 	<ul style="list-style-type: none"> • If you won't be using the refrigerator for a long time, empty the ice bucket and turn off the ice maker.
	<ul style="list-style-type: none"> • Ice bucket is not properly inserted. 	<ul style="list-style-type: none"> • Make sure the ice bucket is properly inserted.
	<ul style="list-style-type: none"> • Water line is not connected properly or water supply is not on. 	<ul style="list-style-type: none"> • Check if the water line is installed correctly. Check if the water line stop cock is closed.

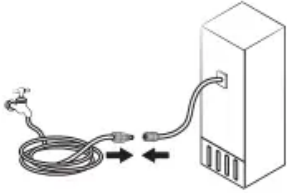
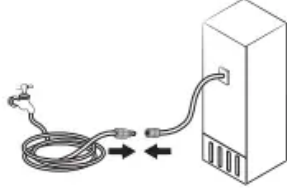
		
Water does not dispense.	<ul style="list-style-type: none"> • Water line is not connected properly or water supply is not on. 	<ul style="list-style-type: none"> • Check if the water line is installed correctly. Check if the water line stop cock is closed. 
	<ul style="list-style-type: none"> • Dispenser Lock is activated. 	<ul style="list-style-type: none"> • Deactivate dispenser Lock.
	<ul style="list-style-type: none"> • A third-party water filter was installed. 	<ul style="list-style-type: none"> • Use only Samsung-provided or approved filters. • Unapproved filters may leak and damage the refrigerator.
	<ul style="list-style-type: none"> • Water filter indicator turns on or blinks. 	<ul style="list-style-type: none"> • Replace the water filter. After replacing, reset the filter indicator sensor.

Do you hear abnormal sounds from the refrigerator?

Before calling for service, review the checkpoints below. Any service calls related to normal sounds will be charged to the user.

These sounds are normal.

- When starting or ending an operation, the refrigerator may make sounds similar to a car engine igniting. As the operation stabilizes, the sounds will decrease.

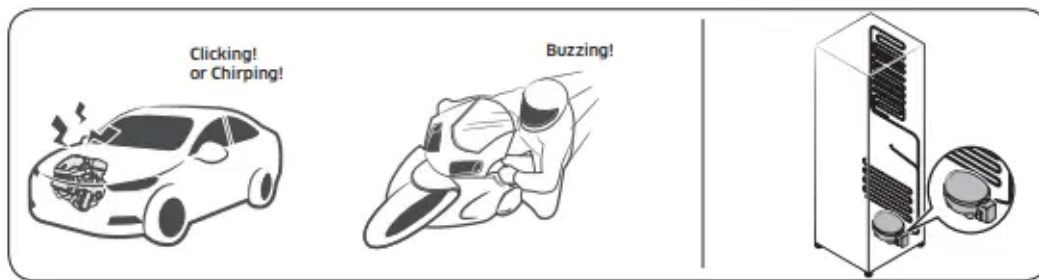

- While the fan is operating, these sounds may occur. When the refrigerator reaches the set temperature, no fan sound will occur.



- During a defrost cycle, water may drip on the defrost heater, causing sizzling sounds.

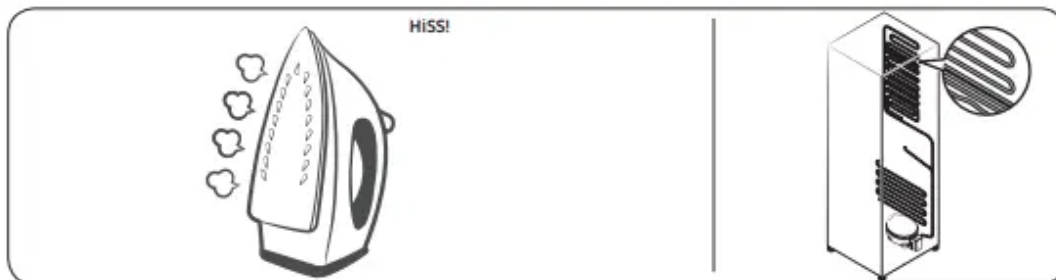

- As the refrigerator cools or freezes, refrigerant gas moves through sealed pipes, causing bubbling sounds.

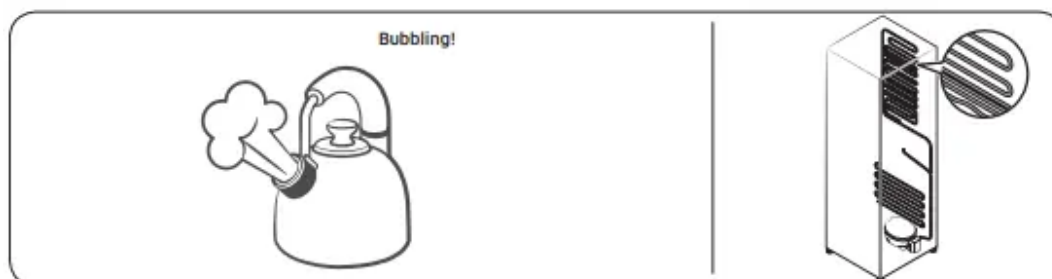

- As the refrigerator temperature increases or decreases, plastic parts contract and expand, creating knocking noises. These noises occur during the defrosting cycle or when electronic parts are working.

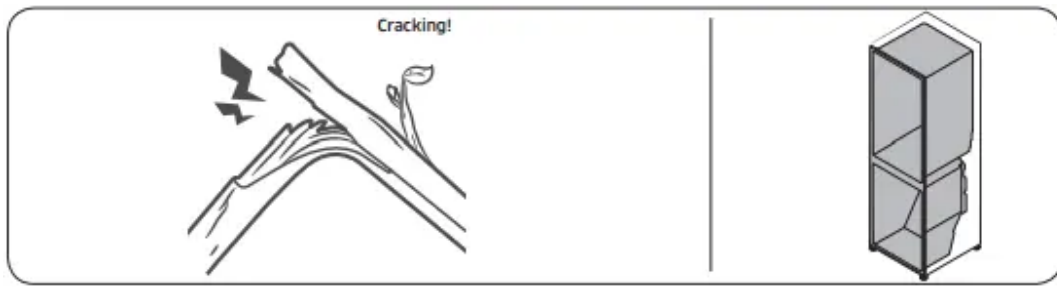

- For ice maker models: When the water valve opens to fill the ice maker, buzzing sounds may occur.
- Due to pressure equalizing when opening and closing the refrigerator door, whooshing sounds may occur.

SmartThings

Symptom	Action
<p>Could not find "SmartThings" in the app market.</p>	<ul style="list-style-type: none"> • The SmartThings app is not available for some tablet and iPad and some smartphone. - support that [Android] OS 6.0 or higher(minimum 2GB RAM Size) - support that [iOS]10.0 or higher/iPhone6 or higher.
<p>The SmartThings app fails to operate.</p>	<ul style="list-style-type: none"> • The SmartThings app is available for applicable models only. • The old Samsung Smart Refrigerator app cannot connect with Samsung Smart Home models.
<p>The SmartThings app is installed but is not connected to my refrigerator.</p>	<ul style="list-style-type: none"> • You must log into your Samsung account to use the app. • Make sure that your router is operating normally. • If you have not connected your refrigerator to the SmartThings App after the app was installed, you must make the connection using the device registration function of the app.
<p>Could not log into the app.</p>	<ul style="list-style-type: none"> • You must log into your Samsung account to use the app. • If you don't have a Samsung account, follow the app's onscreen instructions to create one.
<p>An error message appears when I try to register my refrigerator.</p>	<ul style="list-style-type: none"> • Easy Connection may fail due to the distance from your access point (AP) or electrical interference from the surrounding environment. Wait a moment and try again.
<p>The SmartThings app is successfully connected to my refrigerator but does not run.</p>	<ul style="list-style-type: none"> • Exit and restart the SmartThings app or disconnect and reconnect the router. • Unplug the power cord of the refrigerator, and then plug it in again after 1 minute.



Samsung Family Hub

Symptom	Action
Could not find "Samsung Family Hub" in the app market.	<ul style="list-style-type: none">• The Samsung Family Hub app is not available for some tablet and iPad and some smartphone.<ul style="list-style-type: none">- support that [Android] OS 6.0 or higher(mimimum 2 GB RAM Size)- support that [iOS]10.0 or higher/iPhone 6 or higher.
Could not log into the app.	<ul style="list-style-type: none">• You must log into your Samsung account to use the app.• If you don't have a Samsung account, follow the app's onscreen instructions to create one.



LCD

Symptom	Action
Cannot connect to my TV.	<ul style="list-style-type: none">• This refrigerator can connect only with Samsung Smart TV Launched in 2015~17 : J/K/MU6400 series or above. Launched in 2018 : NU7400 series or above, Launched in 2018 : Q60R series or above. Please check the model name of your TV first.• Network connections may suffer temporary interruptions. Turn your TV off, and then try again.
The inner view picture looks bulged out or incomplete.	<ul style="list-style-type: none">• The edges of the inner view may look bulged out. The bulging is caused by the convex lens of the camera.• The inner view may be incomplete due to the blind spots on the left and right corners or screened depending on the layout of food items. Make sure to place food items in the front center.
The displayed measurement on the Fridge Manager is not correct.	<ul style="list-style-type: none">• The displayed conditions may differ from the actual temperature and humidity.

Smart Grid (applicable models only)

Symptom	Action
<p>What Do I Need to use the Energy Management and Smart Grid functions?</p>	<p>To use the Smart Grid (Demand Response) and Energy Management functions on your refrigerator, you need the following:</p> <p>Devices</p> <ul style="list-style-type: none"> • A wireless access point (router) • A Samsung Energy Management-supported refrigerator • A smartphone Registration • Connect your refrigerator to your home Wi-Fi network. • Register for the EMS service with your electric company. Your electric company must have an EMS (Energy Management System) supporting SEP (Smart Energy profile). <p>App</p> <ul style="list-style-type: none"> • Download the SmartThings app from the Google Play Store, Apple App Store, or Samsung Galaxy Apps. • Install and run the SmartThings app on your smartphone.
<p>Why isn't the Energy Management function working normally?</p>	<ul style="list-style-type: none"> • Make sure that your home router is operating normally with proper Internet service and connection. • Make sure that the refrigerator is connected to the AP (router). Checkpoints • Connect your smartphone to the router (AP, Access Point), and then check if you can browse the Internet on the smartphone.
<p>Why isn't the Delay Defrost Capability working normally?</p>	<ul style="list-style-type: none"> • Make sure that your home router is operating normally with proper Internet service and connection.

Warning

This content is compiled from multiple sources and is provided for reference purposes only. It may not be complete or fully applicable to all situations. If you are unable to resolve your issue, please contact the product manufacturer or an authorized service provider for official support.

Document generated by [ManualsFile](#)

