

## Specifications

- **Standard:** DECT 6.0 (Digital Enhanced Cordless Telecommunications 6.0)
- **Frequency range:** 1.92 GHz to 1.93 GHz R RF transmission power: 115 mW (max.)
- **Power source:** 120 V AC, 60 Hz R Power consumption: **Base unit\*1:** Standby: Approx. 0.8 W **Maximum:** Approx. 4.3 W **Base unit\*2:** Standby: Approx. 1.0 W **Maximum:** Approx. 8.3 W
- **Operating conditions:** 0 °C – 40 °C (32 °F – 104 °F), 20 % – 80 % relative air humidity (dry)

\*1 KX-TGM420

\*2 KX-TGM450

## Getting Started

### Setting up

#### Connections

1. Connect the AC adaptor to the unit by pressing the plug firmly.
2. Fasten the cord by hooking it.
3. Connect the AC adaptor to the power outlet.
4. Connect the telephone line cord to the unit, then to the single-line telephone jack (RJ11C) until you hear a click.
5. A DSL/ADSL filter (not supplied) is required if you have a DSL/ ADSL service.

#### Note:

- The AC adaptor and telephone line cord come connected to the base unit at the time of shipment.
- Use only the supplied Panasonic AC adaptor.\*1

\*1 PNLV226: KX-TGM420

PNLV236: KX-TGM450

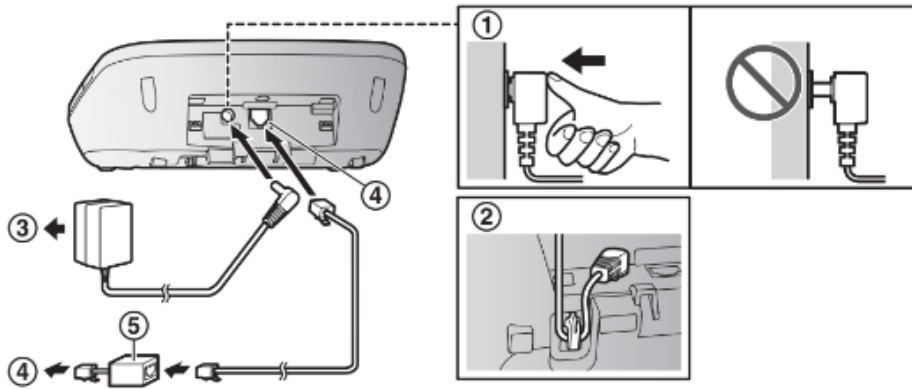

## Handset battery charging

2 rechargeable Ni-MH batteries are installed in the handset at the time of shipment.

**Before initial use:** Remove the yellow insulation sheet before using the handset.

Charge for about 7 hours.

- Confirm “Charging” is displayed (A).
- When the batteries are fully charged, “Fully charged” is displayed.



## Handset battery level

Icon	Battery level
	High
	Medium
	Low
	Needs charging.
	Empty

## Panasonic Ni-MH battery performance

Operation	Operating time
In continuous use	13 hours max.*1
Not in use (standby)	9 days max.*1

\*1 If eco mode is on and booster is off

### Handset battery installation (for replacement)

- USE ONLY rechargeable Ni-MH batteries AAA (R03) size (A).
- Do NOT use alkaline/manganese/Ni-Cd batteries.
- Confirm correct polarities (⊕, ⊖).

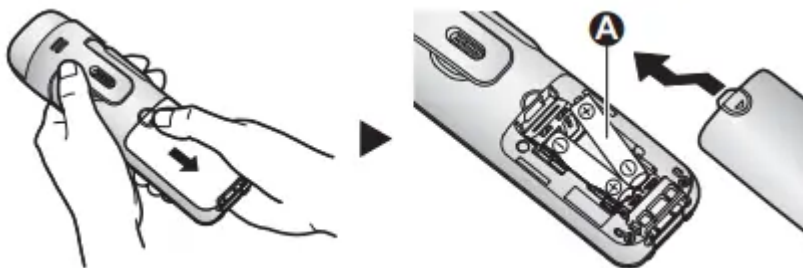

### Base unit backup batteries

2 rechargeable Ni-MH batteries are installed in the base unit at the time of shipment. These batteries can be used to supply power to the base unit in the event of a power failure.

**Before initial use:** Remove the yellow insulation sheet before using the base unit.

### Base unit battery status when a power failure occurs

Item	Battery status
<i>PF</i>	Power backup mode is on.*1
<i>PF</i> (flashing)	Battery power is low.*2

\*1 When the base unit is running on battery power, “*PF*” is displayed on the message counter of the base unit. If there is other information that can be displayed, such as the number of answering system messages, the other information is displayed.

\*2 When the base unit is running on battery power and the remaining battery power is too low, “*PF*” flashes and the base unit beeps. Additionally, the base unit’s message indicator flashes.

### Panasonic Ni-MH battery performance when operating on backup battery power

Operation	Operating time
In continuous use	3 hours max.



Operation	Operating time
In continuous use	3 hours max.

**Note:**

- Battery performance depends on the type of batteries.
- Actual battery performance depends on usage and ambient environment.
- If the base unit is running on battery power, the brightness of the message counter on the base unit is reduced to save battery power.
- When the base unit is running on battery power, the maximum ringer volume of the base unit will be reduced.
- If your phone service provider requires additional devices in order to make and receive calls, such as a modem, you may still not be able to make and receive calls even if the base unit's backup power feature is functioning.

**Base unit battery installation (for replacement)**

**Important:**

- The following AAA (R03) size batteries can be used with the base unit:
  - Rechargeable Ni-MH batteries\*1
  - Standard (non-rechargeable) alkaline batteries\*2
- Do NOT use manganese batteries.
- Confirm correct polarities (  ,  )

\*1 The base unit can fully charge Ni-MH batteries in about 15 hours.

\*2 If the rechargeable batteries become depleted during a power failure, you can insert alkaline batteries into the base unit. Remove the alkaline batteries when power is restored.

**1** Disconnect the telephone line cord (**1**)

**2** Open the battery cover (**2**)

**3** Install the batteries in the battery compartment (**3**)

**4** Close the cover (**4**), then reconnect the telephone line cord (**5**)

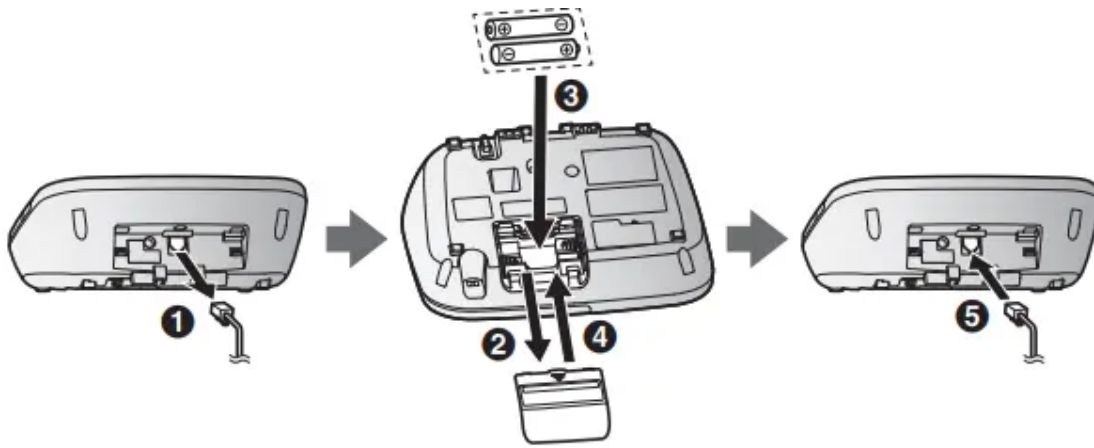

### Note when setting up

### Note for connections

- The AC adaptor must remain connected at all times. (It is normal for the adaptor to feel warm during use.)
- The AC adaptor should be connected to a vertically oriented or floor-mounted AC outlet. Do not connect the AC adaptor to a ceiling-mounted AC outlet, as the weight of the adaptor may cause it to become disconnected.

### Note for battery installation

- Use the supplied rechargeable batteries. For replacement, we recommend using the Panasonic rechargeable batteries noted on page 5, 8.

### Note for battery charging

- It is normal for the handset to feel warm during charging.
- Clean the charge contacts of the handset, base unit, and charger with a soft and dry cloth once a month. Before cleaning the unit, disconnect from power outlets and any telephone line cords. Clean more often if the unit is exposed to grease, dust, or high humidity.

### Intelligent eco mode

This feature automatically reduces handset power consumption by suppressing handset transmission power when the handset is close to the base unit.

- When this feature is activated, **ECO** is displayed.
- Eco mode is turned off when the sound enhancer is activated (page 34).

## Controls

### Handset

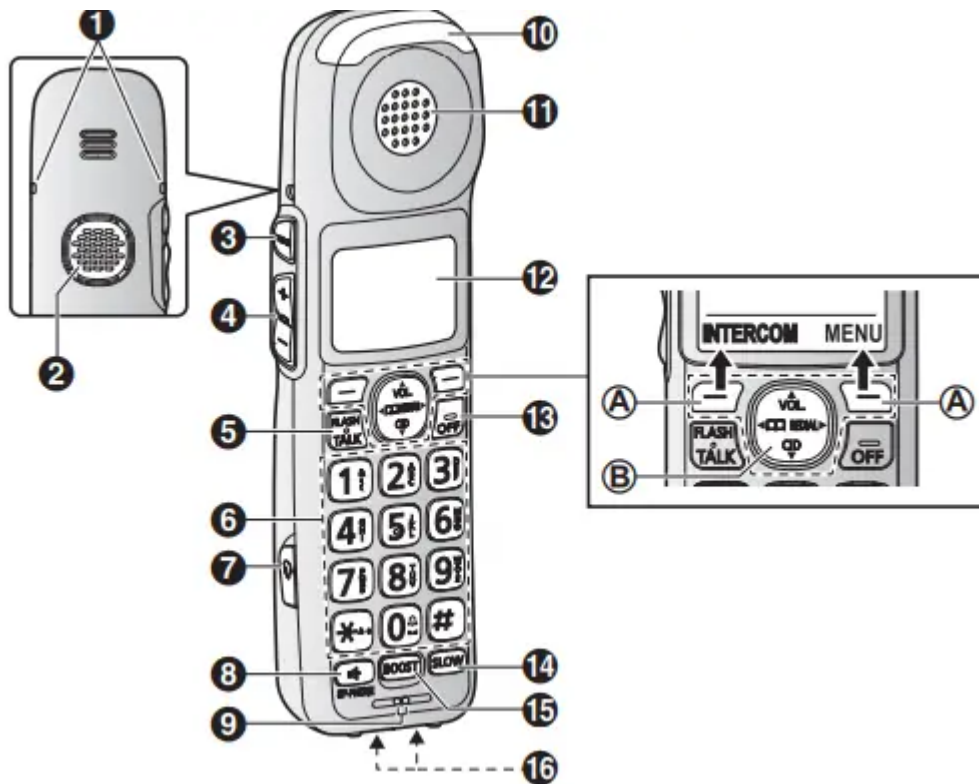

**1. Belt clip holes**

- The belt clip comes attached to the handset at the time of shipment.

**2. Speaker**

**3. [TONE] MTONEN**

**4. [+]/[-] (Tone control)**

**5. [FLASH] [TALK] (VOL.: Volume up/down)**

**6. Dial keypad**

**[\*]**: Temporary tone dialing

**[0]**: (📵) Ringer off

**7. Headset jack**

- This jack is used to connect an optional headset (page 5) or a user-supplied neckloop to the handset. You must set the “**Headset type**” setting to match the type of device connected (page 30).

**8. [SP-PHONE] (SP-PHONE: Speakerphone)**

**9. Microphone**



## 10. Message indicator

## 11. Receiver

## 12. Display

## 13. [OFF]

## 14. [SLOW] (SLOW TALK)

### SLOW TALK indicator

## 15. [BOOST] BOOST indicator

- Light off: Volume booster is turned off.

Light in red: Volume booster is turned on.

Note that when the BOOST indicator is lit in red, the volume booster feature is enabled and the product may emit sounds at very high volume.

## 16. Charge contacts

- Control type

### A Soft keys

By pressing a soft key, you can select the feature shown directly above it on the display.

### B Navigator key

- [▲], [▼], [◀] or [▶]: Scroll through various lists and items.
- VOL. (Volume: [▲], [▼]): Adjust the receiver or speaker volume while talking.
- [◀], : View the phonebook entry
- [▶] REDIAL: View the redial list.
- [▼] CID (Caller ID): View the caller list

### Base unit

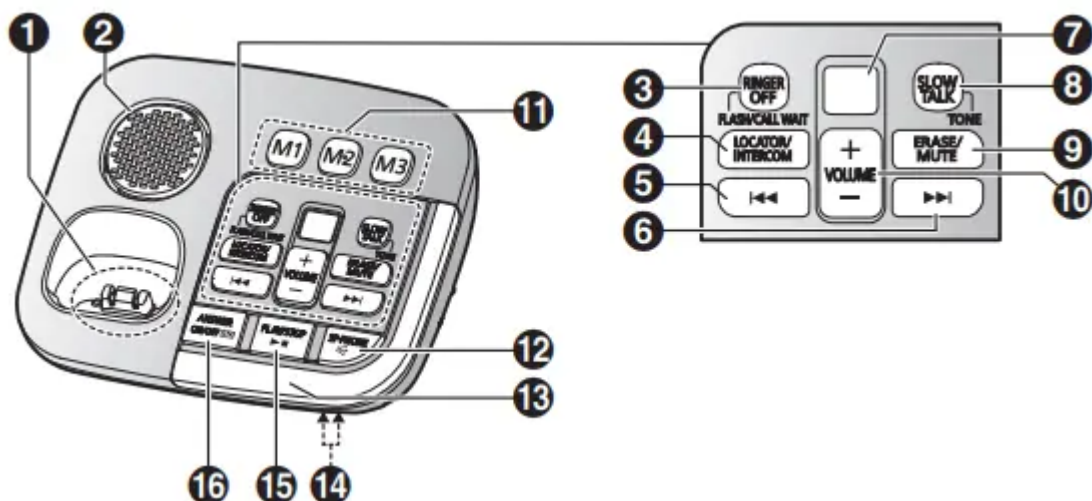

1. Charge contacts

2. Speaker

3. MRINGER OFFN

RINGER OFF indicator

MFLASH/CALL WAITN

4. MLOCATOR/INTERCOMN

- You can locate a misplaced handset by pressing MLOCATOR/INTERCOMN.

5. **[⏮]** (Repeat)

6. **[⏭]** (Skip)

7. Message counter

8. MSLOW TALKN

SLOW TALK indicator

MTONEN (Tone control)

9. MERASE/MUTEN

10. **[+]/[-]** (VOLUME: Volume up/down)

11. **[M1]** (Memory dial 1)

**[M2]** (Memory dial 2)

**[M3]** (Memory dial 3)

12. **[☎]** (SP-PHONE: Speakerphone)

SP-PHONE indicator 

13. Message indicator

14. Microphone

15.  (PLAY/STOP)











New Message/Play indicator 

16. MANSWER ON/OFFN

ANSWER ON/OFF indicator 

## Display icons

### Handset display items

Item	Meaning
	Within base unit range
	Out of base unit range
	Sound enhancer is on. (page 34)
	The line is in use. <ul style="list-style-type: none"><li>• When flashing: The call is put on hold.</li><li>• When flashing rapidly: An incoming call is now being received.</li></ul>
	Speech booster is on. (page 26)
<b>ECO</b>	Eco mode is on. (page 16)
<b>NR</b>	Noise reduction is set. (page 34)
<b>T1 – T6</b> <b>CT</b>	Tone control level (Tone 1-6 or Custom tone)
	Speakerphone is on. (page 32)
	Ringer volume is off. (page 33, 44)
	Silent mode is on. (page 50)
<b>PRIV.</b>	Call sharing mode is off. (page 47)
	Alarm is on. (page 49)
<b>1</b>	Handset number
	Battery level
	Blocked call (page 37)
<b>In use</b>	Answering system is being used by another handset or the base unit.
<b>Line in use</b>	Someone is using the line.

## Base unit display items

Item	Meaning
<i>GO</i>	"Greeting only" is selected. Caller messages are not recorded. (page 59)
<i>PF</i>	Power backup mode is on. (page 14)

## Language settings

### Display language

1. **[MENU]#110**
2. **[↕]**: Select the desired setting → **[SAVE]** → **[OFF]**

### Voice announcement language

You can select the language used for the following features.

- Answering system guidance
- Talking Caller ID
- Talking keypad and phonebook

1. **[MENU]#112**
2. **[↕]** Select the desired setting. → **[SAVE]** → **[OFF]**
  - The setting will be applied in about 5 seconds.

### Date and time

1. **[MENU]#101**
2. Enter the current month, date, and year by selecting 2 digits for each.

**Example:** July 12, 2016

**07 12 16**

3. **[OK]**
4. Enter the current hour and minute (12-hour clock format) by selecting 2 digits for each.

**Example:** 9:30

**09 30**

5. **[\*]**: Select “AM” or “PM”.

6. **[SAVE] → [OFF]**

### Recording your greeting message

You can record your own greeting message instead of using a pre-recorded greeting message. See page 54 for details

1. **[MENU]#302**

2. **[↕]: “Yes” → [SELECT]**

3. Record a greeting message. **→ [STOP] → [OFF]**

### Other settings

#### Dialing mode

If you cannot make calls, change this setting according to your telephone line service. The default setting is “Tone”.

“Tone”: For tone dial service.

“Pulse”: For rotary/pulse dial service.

1. **[MENU]#120**

2. **[↕]**: Select the desired setting. **→ [SAVE] → [OFF]**

### Accessibility

This product is designed to provide not only optimal volume, but optimal sound quality as well, ensuring that every call is heard loud and clear.

#### Tone control

This feature clarifies the voice of the person you are talking to, producing a more natural-sounding voice that is easier to hear and understand. This feature can be set for each unit.

The following settings are available.

Handset:

– Receiver: “Tone 1-6” and “Custom tone 1-20”

– Speakerphone: “Tone 1-4”

– Headset: “Tone 1-4” and “Custom tone 1-20”

Base unit: “**1-4**” (Tone 1-4)

### Handset

You can select a tone control setting while talking on the phone. There are two methods available.

#### - Using the [TONE] key

1 Press [TONE] on the side repeatedly to select the desired setting while talking.

2 To exit, press [BACK] or wait for a few seconds.

- The selected setting is shown on the handset display while talking.

**Note:** To select one of the “Custom tone” settings, follow the instructions in “Using the MMENUN key”, page 23.

#### - Using the [MENU] key

1 Press [MENU] while talking.

2 **[↕]**: “Tone control” → [SELECT]

3. **[↕]**: Select the desired setting. → [OK]

- If you select “Custom tone”, select the desired type.
- The selected setting is shown on the handset display while talking.

### Base unit

1. Press and hold [TONE] for about 2 seconds while talking.

2 Press **[+] or [-]** repeatedly to select the desired setting.

- The selected setting flashes on the message counter while talking.

3 To exit, press [TONE] or wait for about 5 seconds.

### Volume booster

This feature allows you to drastically increase the volume of the other party’s voice. This feature can be set for each unit.

#### Turning on the volume booster

1 Press [BOOST] while on a call.

- The BOOST indicator lights in red.

2 Press **[+] or [-]** on the side repeatedly to select the desired volume.

- The selected volume setting is shown on the handset display while talking.
- The selected volume setting is used for future calls when the booster is turned on.

## Turning on auto boost

If the auto boost feature is turned on, volume booster turns on automatically when you make or answer a call. This feature is useful if the unit is used mainly by a user who is hard of hearing.

1. **[MENU]#782**
2. **[↕]**: Select the desired setting. → **[SAVE]** → **[OFF]**

## Adjusting the volume

While on a call, you can adjust the volume by pressing **[+]** or **[-]** on the side repeatedly. The selected volume setting is shown on the handset display. The selected volume setting is applied immediately and is also used for future calls. A separate setting is used for when volume booster is on and when it is off.

### Available volume settings

The available settings vary by model and whether volume booster is turned on or off.

BOOST indicator	Volume booster	Available volume settings	Default
Light off	Turned off	Receiver: 1–15	15
		Speakerphone: 1–21	15
		Headset: 1–15	15

### Accessibility

BOOST indicator	Volume booster	Available volume settings	Default
Light in red	Turned on	<b>KX-TGM420 series</b>	
		Receiver: 12–40	15
		Speakerphone: 18–30	21
		Headset: 12–40	15
		<b>KX-TGM450 series</b>	
		Receiver: 12–50	15
		Speakerphone: 18–40	21
		Headset: 12–50	15

## Speech booster (making your voice louder)

This feature allows you to increase the volume of your voice heard by the other party. This feature can be set for each handset.

- 1 Press **[MENU]** while on a call.
- 2 **[↕]**: “Boost speech on” or “Boost speech off” → **[SELECT]**

- The selected setting is applied immediately and is also used for future calls.

**Note:** You can set this feature in standby mode (page 45).

## Programming

### Menu list

To access the features, there are 2 methods.

#### Scrolling through the display menus

1. **[MENU]**

2. Press **[▼]** or **[▲]** to select the desired main menu. → **[SELECT]**

3. Press **[▼]** or **[▲]** to select the desired item from the next sub-menus. → **[SELECT]**

4. Press **[▼]** or **[▲]** to select the desired setting. → **[SAVE]**

#### Using the direct command code

1. **[MENU]** → Enter the desired code.

Example: Press **[MENU]#101**.

2. Select the desired setting. → **[SAVE]**

## Display menu tree and direct command code table

Main menu:  "Phonebook"

Operation	Code	
Viewing the phonebook entry.	#280	40

Main menu:  "Caller list"

Operation	Code	
Viewing the caller list.	#213	52

Main menu:  "Answering device"

Sub-menu 1	Sub-menu 2	Settings	Code	
Play new message	–	–	#323	55
Play all message	–	–	#324	55
Erase all message <sup>*1</sup>	–	–	#325	56
Greeting	Record greeting <sup>*1</sup>	–	#302	54
	Check greeting	–	#303	55
	Pre-recorded <sup>*1</sup> (Reset to pre-recorded greeting)	–	#304	55

Sub-menu 1	Sub-menu 2	Settings	Code	
New message alert <sup>*1</sup>	Outgoing call – On/Off	On <Off>	#338	56
	Outgoing call – Notification to	–		
	Outgoing call – Remote code	Activate <Inactivate>		
	Base unit beep	On <Off>	#339	56
Settings	Ring count <sup>*1</sup>	Toll saver 2-7 rings <4 rings>	#211	59
	Recording time <sup>*1</sup>	<3 min> 1 min Greeting only <sup>*2</sup>	#305	59
	Remote code <sup>*1</sup>	<111>	#306	58
	Screen call – Handset	<On> Off	#310	59
	Screen call – Base unit <sup>*1</sup>	<On> Off	#*310	
Answer on <sup>*1</sup>	–	–	#327	54
Answer off <sup>*1</sup>	–	–	#328	54

Main menu:  "Voicemail access"

Operation	Code	
Listening to voicemail messages.	#330	61

Main menu: 📞 "Intercom"

Operation	Code	
Paging the desired unit.	#274	35

Main menu: ⌚ "Set date & time"

Sub-menu 1	Sub-menu 2	Settings	Code	
Date and time <sup>*1</sup>	-	-	#101	21
Memo alarm	Alarm1-3	<Off>, Once, Daily, Weekly	#720	49
Time adjustment <sup>*1, *3</sup>	-	<Caller ID auto> Manual	#226	-

Main menu: 📞 "Memory dial"

Operation	Code	
Viewing the memory dial entry.	#261	41



Main menu:  "Settings"

Sub-menu 1	Sub-menu 2	Settings	Code	
Ring adjustments	Ringer volume (Incoming) - Handset	Off-6 <6>	#160	-
	Ringer volume (Incoming) - Base unit*1	Off-10 <1>	#*160	-
	Intercom ringer volume - Handset	1-6 <6>	#175	-
	Intercom ringer volume - Base unit*1	1-10 <1>	#*175	-
	Ringer tone (Incoming) - Handset*4, *5, *6	<Ringer 1>	#161	-
	Ringer tone (Incoming) - Base unit*1, *4, *6	<Ringer 1>	#*161	-
	Intercom ringer tone - Handset*4, *5, *6	<Ringer 3>	#163	-
	Intercom ringer tone - Base unit*1, *4, *6	<Ringer 3>	#*163	-
	Silent mode - Handset	On/Off - On - <Off>	#238	50
		Start/End - <11:00 PM/ 06:00 AM>	#237	50
		Select group Group 1-9	#241	50
	Silent mode - Base unit*1	On/Off - On - <Off>	#*238	50
		Start/End - <11:00 PM/ 06:00 AM>	#*237	50
		Select group Group 1-9	#*241	50

## Programming

Sub-menu 1	Sub-menu 2	Settings	Code	
Audio settings	Talking dial - Handset	<Off> Low High	#750	26
	Talking dial - Base unit <sup>*1</sup>	<Off> Low High	#*750	
	Talking caller ID - Handset	<On> Off	#162	52
	Talking caller ID - Base unit <sup>*1</sup>	On <Off>	#*162	
	Auto boost	On <Off>	#782	25
	Boost speech	On <Off>	#783	26
	Key tone - Handset	Off <Low> High	#165	27
	Key tone - Base unit <sup>*1</sup>	Off <Low> High	#*165	
Set date & time	Date and time <sup>*1</sup>	-	#101	21
	Memo alarm - Alarm1-3	<Off> Once Daily Weekly	#720	49
	Time adjustment <sup>*1,*3</sup>	<Caller ID auto> Manual	#226	-

## Programming

Sub-menu 1	Sub-menu 2	Settings	Code		
<b>Key detector setting<sup>7</sup></b> - 1: Add new device (for Detector1) <sup>8</sup> - 2: Add new device (for Detector2) - 3: Add new device (for Detector3) - 4: Add new device (for Detector4)	Change name <sup>1</sup>	Detector1	#6561	-	
		Detector2 <sup>9</sup>	#6562 <sup>9</sup>		
		Detector3 <sup>9</sup>	#6563 <sup>9</sup>		
		Detector4 <sup>9</sup>	#6564 <sup>9</sup>		
	Registration	-		#6571	-
				#6572 <sup>9</sup>	
				#6573 <sup>9</sup>	
				#6574 <sup>9</sup>	
	Deregistration	-		#6581	-
				#6582 <sup>9</sup>	
				#6583 <sup>9</sup>	
				#6584 <sup>9</sup>	
Call block <sup>1</sup>	Block a single number	-	#217	37	
	Block range of numbers	-		38	
	Block unknown CID (CID: Caller ID)	Block <Unblock>	#240	38	
	One ring for blocked call	<Yes> No	#173	38	
Memory dial	-	-	#261	41	
Record greeting <sup>1</sup>	-	-	#302	54	
Voicemail	Save VM access# <sup>1</sup> (VM: Voicemail)	-	#331	60	
	VM tone detect <sup>1</sup>	<On> Off	#332	60	
LCD contrast (Display contrast)	-	Level 1-4 <2>	#145	-	
Handset name	-	-	#104	50	
Display name	-	On <Off>	#105	50	

Sub-menu 1	Sub-menu 2	Settings	Code	
Message indicator	Handset – Incoming call	<On> Off	#278	28
	Handset – New message	<On> Off		
	Handset – New VM	<On> Off		
	Handset – Missed call	On <Off>		
	Handset – Alarm	<On> Off		
	Base unit <sup>*1</sup> – Incoming call	<On> Off	#*278	
	Base unit <sup>*1</sup> – New message	<On> Off		
	Base unit <sup>*1</sup> – New VM	<On> Off		
	Base unit <sup>*1</sup> – Missed call	On <Off>		
	Caller ID edit (Caller ID number auto edit)	–	<On> Off	#214
Auto talk <sup>*10</sup>	–	On <Off>	#200	32
Set tel line	Set dial mode <sup>*1</sup>	<Tone> Pulse	#120	22
	Set flash time <sup>*1, *11</sup>	80 ms 90 ms 100 ms 110 ms 160 ms 200 ms 250 ms 300 ms 400 ms 600 ms <700 ms> 900 ms	#121	34
	Set line mode <sup>*1, *12</sup>	A <B>	#122	–
Call sharing <sup>*1</sup>	–	<On> Off	#194	34
Registration	Register handset	–	#130	50
	Deregistration <sup>*2</sup>	–	#131	51

## Programming

Sub-menu 1	Sub-menu 2	Settings	Code	
Headset type	-	<Headset> Neckloop with Mic Neckloop w/o Mic	#786	30
Change language	Display	<English> Español	#110	21
	Announcement* <sup>1</sup>	<English> Español	#112	21

Main menu:  "Customer support"

Operation	Code	
Displaying customer support Web address.	#680	-

Main menu:  "Key detector"\*<sup>7</sup>

Sub-menu 1	Sub-menu 2	Settings	Code	
Search	-	-	#655	-
Battery check	-	-		

\*1 If you program these settings using one of the units, you do not need to program the same item using another unit.

\*2 This menu is not displayed when scrolling through the display menus. It is only available in direct command code.

\*3 This feature allows the unit to automatically adjust the date and time each time caller information including date and time is received.

To turn this feature on, select "Caller ID auto". To turn this feature off, select "Manual". (Caller ID subscribers only)

To use this feature, set the date and time first (page 21).

\*4 If you subscribe to a distinctive ring service (such as IDENTIA RING), select one of the ringers ("Ringer 1" to "Ringer 5").

\*5 The preset ringers in this product ("Ringer 6" - "Ringer 15") are used with permission of © 2004 - 2013 Copyrights Vision Inc.

\*6 If you select one of the ringers ("Ringer 1" to "Ringer 5"), select the desired frequency ("Frequency 1" to "Frequency 6").

\*7 This setting is available when you have the key detector (KX TGA20). Read the installation manual for more information on the key detector.

\*8 For models with supplied key detectors, the display shows "1: Detector1".

\*9 If you register 2 or more key detectors.

\*10 If you subscribe to a Caller ID service and want to view the caller's information after lifting up the handset to answer a call, turn off this feature.

\*11 The flash time depends on your telephone exchange or host PBX. Contact your PBX supplier if necessary. The setting should stay at "700 ms" unless pressing MFLASHN fails to pick up the waiting call.

\*12 Generally, the line mode setting should not be changed. This setting automatically maintains receiver volume at the proper level depending on the current telephone line condition. Set the line mode to "A" if telephone line condition is not good.

## Alarm

An alarm sounds at the set time for 1 minute and repeats 5 times at 5 minute intervals (snooze function). You can also configure the alarm to display a text memo. You can set 3 separate alarms for each handset. Each alarm can be set to sound once, daily, or weekly.

When an alarm sounds, the message indicator flashes rapidly if the handset message indicator's "Alarm" setting is enabled (page 28).

1. **[MENU]** **#720**
2. **[↕]**: Select the desired alarm. → **[SELECT]**
3. → **[SELECT]** Select the desired alarm option. → **[SELECT]**

<b>"Off"</b> Turns alarm off. Go to step 10.
<b>"Once"</b> An alarm sounds once at the set time.
<b>"Daily"</b> An alarm sounds daily at the set time. Go to step 5.
<b>"Weekly"</b> Alarm sounds weekly at the set time(s).

4. Proceed with the operation according to your selection in step 3.

- **Once:**

Enter the desired month and date. **[OK]**

- **Weekly:**

**[↕]**: Select the desired day of the week and press **[SELECT]**. → **[OK]**

5. Set the desired time.

6. **[X]**: Select **"AM"** or **"PM"**. → **[OK]**

7. Enter a text memo (10 characters max.). → **[OK]**

8. **[↕]**: Select the desired alarm tone. → **[SELECT]**

- If you select one of the ringers

Ringer 1” to “Ringer 5”), select the desired frequency (“Frequency to “Frequency 6”).

- We recommend selecting a different ringer tone from the one used for outside calls and intercom calls.

9. **[↕]**: Select the desired snooze setting. → **[SAVE]**

**10 [SELECT] → [OFF]**

## Silent mode

Silent mode allows you to select a period of time during which the handset and/or base unit will not ring for outside calls. This feature is useful for time periods when you do not want to be disturbed, for example, while sleeping. Silent mode can be set for each unit.

Using the phonebook’s group feature page 39), you can also select groups of callers whose calls override silent mode and ring the unit (Caller ID subscribers only).

### Turning silent mode on/off

1. For handset: **[MENU]#238**

For base unit (using a handset): **[MENU]#\*238**

2. **[↕]**: Select the desired setting. → **[SAVE]**

If you select “Off”, press [OFF] to exit.

3. Enter the desired hour and minute you wish to start this feature.

4. **[\*]**: Select “AM” or “PM”. → **[OK]**

5. Enter the desired hour and minute you wish to end this feature.

6. **[\*]**: Select “AM” or “PM”.

7. **[SAVE] → [OFF]**

### Changing the start and end time

1. **For handset: [MENU]#237**  
**For base unit (using a handset):**  
**[MENU]#\*237**

2. Continue from step 3, “Turning silent mode on/off”, page 50.

### Selecting groups to bypass silent mode

**For handset: [MENU]# 2 4 1**  
**For base unit (using a handset):**  
**[MENU]# \* 2 4 1**

- 1.
2. **[↕]**: Select the desired groups. → **[SELECT]**

“✓” is displayed next to the selected group numbers.

To cancel the selected group:

**[↕]**: Select the group. → Press **[SELECT]** again. “✓” disappears.

**[SAVE] → [OFF]**

- 3.

## Other programming

### Changing the handset name

The default handset name is “Handset 1” to

Handset 6”. You can customize the name of each handset (“Bob”, “Kitchen”, etc.). This is useful when you make intercom calls between handsets. To display the handset name in standby mode, turn on the handset name display feature (page 50).

- 1 **[MENU]# 1 0 4**
- 2 Enter the desired name (10 characters max.). → **[SAVE] → [OFF]**

### Displaying the handset name

You can select whether or not the handset name is displayed in standby mode. The default setting is “Off”.

- 1 **[MENU]# 1 0 5**
- 2 **[↕]**: Select the desired setting. → **[SAVE] → [OFF]**

## Registering a unit

### Operating additional units

Additional handsets

Up to 6 handsets can be registered to the base unit.

Important:

See page 5 for information on the available model.

### Registering a handset to the base unit

The supplied handset and base unit are pre-registered. If for some reason the handset is not registered to the base unit, re-register the handset.

#### 1. Handset:

**[MENU]#130**

#### 2. Base unit:

Press and hold **[LOCATOR/INTERCOM]** for about 5 seconds.

- If all registered handsets start ringing, press **[LOCATOR/INTERCOM]** again to stop, then repeat this step.

Handset:

Press [OK], then wait until a long beep sounds.

### Deregistering a handset

A handset can cancel its own registration to the base unit, or other handsets registered to the same base unit. This allows the handset to end its wireless connection with the system.

- 1 [MENU]#131**
  - All handsets registered to the base unit are displayed.
- 2 [↕]:** Select the handset you want to cancel. → **[SELECT]**
- 3 [↕]:** "Yes" → **[SELECT]** → **[OFF]**

## Troubleshooting

If you still have difficulties after following the instructions in this section, disconnect the base unit's AC adaptor, then reconnect the base unit's AC adaptor. Remove the batteries from the handset, and then insert them into the handset again.

If the base unit batteries for power backup are installed, remove the batteries from the base unit, and then insert them into the base unit again.

### General use

<b>Problem</b>	<b>Cause/solution</b>
The handset does not turn on even after installing charged batteries.	Place the handset on the base unit or charger to turn on the handset.
The unit does not work.	<ul style="list-style-type: none"> <li>• Make sure the batteries are installed correctly (page 14).</li> <li>• Fully charge the batteries (page 13).</li> <li>• Check the connections (page 12).</li> <li>• Unplug the base unit's AC adaptor to reset the unit.</li> <li>• Reconnect the adaptor and try again.</li> <li>• The handset has not been registered to the base unit.</li> <li>• Register the handset (page 50).</li> </ul>
I cannot hear a dial tone.	<p>The base unit's AC adaptor or telephone line cord is not connected. Check the connections.</p> <p>Disconnect the base unit from the telephone line and connect the line to a known working telephone. If the working telephone operates properly, contact our service personnel to have the unit repaired. If the working telephone does not operate properly, contact your phone service provider.</p>
The indicator on the handset or base unit flashes slowly.	<p>New messages have been recorded. Listen to the new messages (page 55).</p> <p>New voicemail messages have been recorded. Listen to the new voicemail messages (page 61).</p>
The base unit beeps.	New messages have been recorded. Listen to the new messages (page 55).
The unit does not work during a power failure.	The batteries inserted in the base unit are depleted. You can insert 2 alkaline batteries into the base unit to provide backup power. Remove the alkaline batteries and reinsert the rechargeable batteries when power is restored (page 15).

## Accessibility

<b>Problem</b>	<b>Cause/solution</b>
I cannot search the phonebook, caller list, redial list, memory dial, or call block list.	Other units are in use and the system is busy. Try again later.
The unit does not announce names or phone numbers when I search the phonebook, caller list, etc.	The default setting for the talking keypad and phonebook feature is "Off". Change the setting (page 26). Other units are in use and the system is busy. Try again later.
The announcement is in a language I cannot understand.	Change the voice announcement language (page 21).
The announcement is too low to be heard.	Change the talking keypad and phonebook setting to "High" (page 27).
I cannot use the slow talk feature.	Other units are in use and the system is busy. Try again later.
When using a neckloop, whistling or feedback is heard, or the other party cannot hear your voice.	The headset type is set to "Headset" or "Neckloop with Mic". Select "Neckloop w/o Mic" (page 30).
When using a headset, the other party says that your voice is very quiet or sounds far away.	The headset type is set to "Neckloop w/o Mic". Select "Headset" (page 30).
When using a neckloop with a built-in microphone, the other party says that your voice is very quiet or sounds far away.	The headset type is set to "Neckloop w/o Mic". Select "Neckloop with Mic" (page 30).





## Menu list

<b>Problem</b>	<b>Cause/solution</b>
The display is in a language I cannot read.	Change the display language (page 21).
I cannot register a handset to a base unit.	The maximum number of handsets (6) is already registered to the base unit. Cancel unused handset registrations from the base unit (page 51).

## Battery recharge

Problem	Cause/solution
The handset beeps and/or  flashes.	Battery charge is low. Fully charge the batteries (page 13).

## Useful Information

Problem	Cause/solution
I fully charged the batteries, but –  still flashes, –  is displayed, or – the operating time seems to be shorter.	Clean the battery ends (  ,  ) and the charge contacts with a dry cloth and charge again. It is time to replace the batteries (page 14).

## Making/answering calls, intercom

Problem	Cause/solution
 is displayed.	<p>The handset is too far from the base unit. Move closer.</p> <p>The base unit's AC adaptor is not properly connected. Reconnect AC adaptor to the base unit.</p> <p>The handset is not registered to the base unit. Register it (page 50).</p>
Noise is heard, sound cuts in and out.	<p>You are using the handset or base unit in an area with high electrical interference. Re-position the base unit and use the handset away from sources of interference.</p> <p>Move closer to the base unit.</p> <p>If you use a DSL/ADSL service, we recommend connecting a DSL/ADSL filter between the base unit and the telephone line jack. Contact your DSL/ADSL provider for details.</p>
The handset does not ring.	<p>The ringer volume is turned off. Adjust the ringer volume (page 33, 44). Silent mode is turned on. Turn it off (page 50).</p> <p>The ringer volume is turned off by pressing and holding 0 (<del>0</del>).</p> <p>Press and hold 0 (<del>0</del>) again to turn it on (page 33).</p>
The base unit does not ring.	<p>The ringer volume is turned off. Adjust the ringer volume (page 33, 44). Silent mode is turned on. Turn it off (page 50).</p> <p>The ringer volume is turned off by pressing MRINGER OFFN. Press MRINGER OFFN again to turn it on (page 33).</p>
I cannot make a call.	<p>The dialing mode may be set incorrectly. Change the setting (page 22).</p>
I cannot make long distance calls.	<p>Make sure that you have long distance service.</p>
I cannot use voice paging.	<p>You cannot use voice paging if other units are in use.</p> <p>Voice paging is not available when a range extender (KX-TGA405) is registered to the base unit.</p>

## Caller ID/Talking Caller ID

<b>Problem</b>	<b>Cause/solution</b>
<p>Caller information is not displayed.</p>	<p>You must subscribe to Caller ID service. Contact your phone service provider for details.</p> <p>If your unit is connected to any additional telephone equipment such as a Caller ID box or cordless telephone line jack, plug the unit directly into the wall jack.</p> <p>If you use a DSL/ADSL service, we recommend connecting a DSL/ADSL filter between the base unit and the telephone line jack. Contact your DSL/ADSL provider for details.</p> <p>The name display service may not be available in some areas. Contact your phone service provider for details.</p> <p>Other telephone equipment may be interfering with this unit. Disconnect the other equipment and try again.</p>
<p>Caller information is displayed or announced late.</p>	<p>Depending on your phone service provider, the unit may display or announce the caller's information at the 2nd ring or later.</p> <p>Move closer to the base unit.</p>
<p>Caller information is not announced.</p>	<p>The handset or base unit's ringer volume is turned off. Adjust it (page 33, 44).</p> <p>The Talking Caller ID feature is turned off. Turn it on (page 45).</p> <p>The number of rings for the answering system is set to "2 rings" or "Toll saver". Select a different setting (page 59).</p> <p>If the base unit and another handset are having an intercom call, your handset does not announce caller information.</p>
<p>The caller list/incoming phone numbers are not edited automatically.</p>	<p>The Caller ID number auto edit feature is turned off. Turn it on and try again (page 47).</p> <p>You need to call back the edited number to activate Caller ID number auto edit.</p>
<p>I cannot dial the phone number edited in the caller list.</p>	<p>The phone number you dialed might have been edited incorrectly (for example, the long distance "1" or the area code is missing). Edit the phone number with another pattern (page 53).</p>
<p>Time on the unit has shifted.</p>	<p>Incorrect time information from incoming Caller ID changes the time. Set the time adjustment to "Manual" (off) (page 45).</p>
<p>The 2nd caller's information is not displayed during an outside call.</p>	<p>In order to use Caller ID, call waiting, or Call Waiting Caller ID (CWID), you must first contact your phone service provider and subscribe to the desired service.</p> <p>After subscribing, you may need to contact your phone service</p>



provider again to activate this specific service, even if you already subscribed to both Caller ID and Call Waiting with Caller ID services (CWID).

## Answering system

Problem	Cause/solution
<p>The unit does not record new messages.</p>	<p>The answering system is turned off. Turn it on (page 54).</p> <p>The message memory is full. Erase unnecessary messages (page 55, 56).</p> <p>The recording time is set to "Greeting only". Change the setting (page 59).</p> <p>Your phone service provider's voicemail service may be answering your calls before the unit's answering system can answer your calls. Change the unit's number of rings setting (page 59) to a lower value, or contact your phone service provider.</p> <p>The answering system will not answer incoming calls while the other devices such as handsets are engaged in a call.</p>
<p>I cannot operate the answering system remotely.</p>	<p>The remote access code is not set. Set the remote access code (page 58).</p> <p>You are entering the wrong remote access code. If you have forgotten your remote access code, enter the remote access code setting to check your current code (page 58).</p> <p>The answering system is turned off. Turn it on (page 58).</p>
<p>The unit does not emit the specified number of rings.</p>	<p>If the first ring is turned off ("No") (page 38), the number of rings decreases by 1 from the specified number of rings.</p>

## Voicemail

Problem	Cause/solution
<p>“Voicemail msg. viaphone co.” is shown on the handset display. How do I remove this message from the display?</p>	<p>This notification is displayed when your phone service provider’s voicemail service (not the unit’s answering system) has recorded a message for you. Typically you can remove this notification from the display by listening to the message. To listen to the message, dial the voicemail number provided by your phone service provider (for most cases, this will be your own phone number), and follow the voice instructions. Depending on your phone service provider, you may need to remove all messages from your voice mailbox to remove the notification. You can also remove this notification by pressing and holding # until the unit beeps.</p>

### Liquid damage

Problem	Cause/solution
<p>Liquid or other form of moisture has entered the handset/base unit.</p>	<p>Disconnect the AC adaptor and telephone line cord from the base unit. Remove the batteries from the base unit and handset and leave to dry for at least 3 days. After the handset/base unit are completely dry, reconnect the AC adaptor and telephone line cord. Insert the batteries and charge fully before use. If the unit does not work properly, contact an authorized service center.</p>

#### Warning

This content is compiled from multiple sources and is provided for reference purposes only. It may not be complete or fully applicable to all situations. If you are unable to resolve your issue, please contact the product manufacturer or an authorized service provider for official support.

