

## Operations

### Feature panel

#### Type 1



#### Type 2



#### Type 3



01 Freezer / Power Freeze

02 Fridge / Power Cool

03 Ice Maker \*

04 Filter Reset \*

05 Door Alarm / Vacation

06 Network connection

\* Applicable models only

#### 01 Freezer / Power Freeze (3 sec)

**Freezer** : The Freezer button can be used to set the freezer temperature, or to activate Power Freeze. Available temperatures are between -15 °C and -23 °C.



**Power Freeze :** Power Freeze speeds up the freezing process at maximum fan speed. The freezer keeps running at full speed for 50 hours and then returns to the previous temperature.

- To activate Power Freeze, press and hold Freezer for 3 seconds. The corresponding indicator (  ) lights up, and the refrigerator will speed up the freezing process for you.
- To deactivate, press and hold Freezer for 3 seconds again. The freezer returns to the previous temperature setting.
- To freeze large amounts of food, activate Power Freeze for at least 20 hours before putting food in the freezer.

## 02 Fridge / Power Cool (3 sec)

**Fridge :** The Fridge button can be used to set the fridge temperature, or to activate/deactivate Power Cool. You can manually adjust the cooling temperature for the fridge. Keep pressing Fridge to select a desired temperature between 1 °C and 7 °C.

**Power Cool :** Power Cool speeds up the cooling process at maximum fan speed. This is useful to quickly cool food that spoils quickly, or after the door is left open for some time. The fridge keeps running at full speed for several hours and then returns to the previous temperature. Press and hold Fridge for 3 seconds. The corresponding indicator (  ) lights up, and the refrigerator will speed up the cooling process for you

## 03 Ice Maker

**Ice Maker :** Press and hold Ice Maker for more than 3 seconds to turn the ice maker on or off. The ice maker has 2 indicators (ON/OFF) to indicate the operating status.

- When the ice maker operates, the ON indicator turns on.
- When the ice maker is turned off, the OFF indicator turns on. In this case, ice making is disabled even if you press the Cubed Ice or Crushed Ice buttons on the dispenser panel. To enable ice making, you must turn the ice maker on.
- When the ice maker is off, pressing the dispenser lever for more than 5 seconds will automatically turn on the ice maker.
- When you turn the ice maker off, you must wait at least 1 minute before you can turn it back on.

## 04 Filter Reset (3 sec)

**Filter Reset :** After about 6 months (approximately 300 gallons) of using the original water filter, the Filter indicator turns red to remind you that the filter needs to be replaced. If this happens, replace the filter, and press and hold Filter Reset for 3 seconds. The filter indicator will be reset, and the Filter indicator turns off.

## 05 Door Alarm / Vacation (3 sec)

**Door Alarm** : You can set the alarm for a reminder. If the door is left open for more than 2 minutes, the alarm will sound with the alarm indicator blinking. The alarm is enabled by factory default. To disable the alarm, press Door Alarm. To enable, press Door Alarm again.

**Vacation** : The Vacation button can be used to activate/deactivate Vacation mode. If you are going on vacation or a business trip, or if you do not intend to use the refrigerator for an extended time, use the Vacation feature. Press and hold Vacation for 3 seconds to turn off the fridge operation with the Vacation indicator (  ) on.

**Device authentication** : When connecting the refrigerator to SmartThings App or Samsung smart devices such as Samsung Smart TVs, follow the app's or device's onscreen instructions and press and hold Door Alarm for 5 seconds. The temperature panel displays "on" for 5 seconds before proceeding with the authentication procedure. Note that the Vacation function will be not affected by this authentication.

## **06 Network connection (applicable models only)**

You can use the optional Smart Home Adapter (sold separately) to control and monitor your refrigerator through the SmartThings app. For more information about SmartThings, see the SmartThings section

### **SmartThings (available only with the optional adapter)**

#### **Installation**

Visit the Google Play Store, Galaxy Apps, or Apple App Store and search for "SmartThings". Download and install the SmartThings app provided by Samsung Electronics to your smart device.

#### **Samsung account**

You are required to register with a Samsung account to use the app. If you don't have a Samsung account, follow the app's onscreen instructions to create a free Samsung account.

#### **Getting started**

1. Insert the Smart Home Adapter into the corresponding port of your refrigerator.
2. Run the SmartThings app and log in with your Samsung account. iPhone users are required to provide the login information each time they access the app.
3. Access Add Device and then tap Refrigerator.
4. Follow the onscreen instructions to provide the necessary information about the router, and then tap Next.
5. Press and hold Fridge for more than 5 seconds until the "AP" message appears on the display. Your refrigerator will be registered with the app.

6. When device registration is complete, the refrigerator icon will appear on the SmartThings app.

7. Tap the refrigerator icon to open the refrigerator page.

8. When a network connection is established, the Wi-Fi icon lights up on your refrigerator.

### Refrigerator app

#### Integrated control

You can monitor and control your refrigerator at home as well as while on the move.

- Tap the refrigerator icon on the SmartThings to open the refrigerator page.
- Check the operation status or notifications for your refrigerator, and change options or settings if necessary.

Category	Item	Description
Monitoring	Fridge temperature	Displays the current temperature setting of the fridge.
	Freezer temperature	Displays the current temperature setting of the freezer.
	Diagnosis	Detects abnormal operations of the refrigerator.
	Energy monitoring	Checks the accumulated power consumption of the refrigerator for the last 180 days.
Functions	Ice making	You can turn the ice making function on or off, and check the current settings of the function.
		You can also check the status and progress of ice making.
	Power Cool	You can turn Power Cool on or off, and check the current settings.
Power Freeze	You can turn Power Freeze on or off, and check the current settings.	
Alarms	Abnormally high temperature	This alarm is triggered when the fridge or freezer has abnormally high temperatures.
	Door opening	This alarm is triggered if the fridge or freezer door is open for more than 2 minutes.
	Water filter replacement	This alarm reminds you that the water filter must be replaced.

#### Dispenser panel (applicable models only)



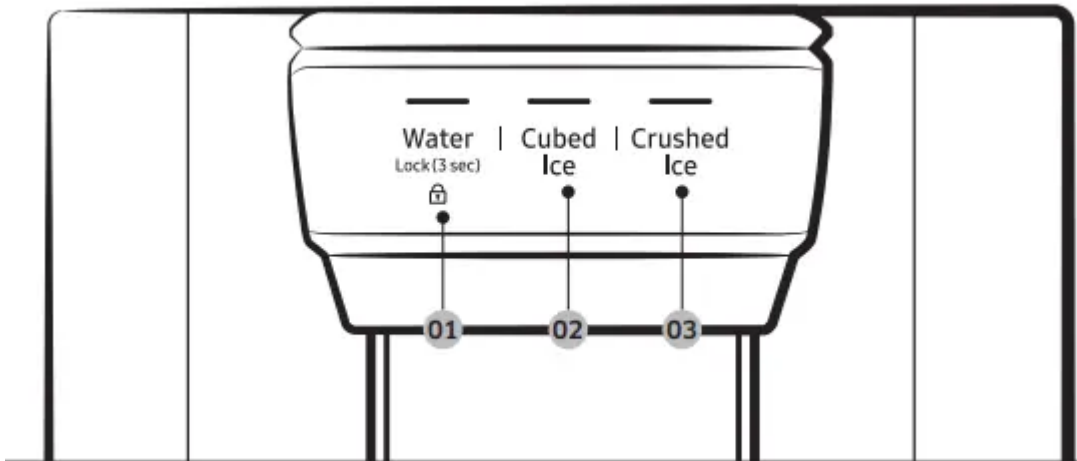

01 Water / Lock

02 Cubed Ice

03 Crushed Ice

### **01 Water / Lock (3 sec)**

**Water** : To dispense chilled water, press Water. The corresponding indicator turns on.

**Lock (Dispenser panel / Dispenser lever)** : To prevent the use of the dispenser panel buttons and the dispenser lever, press and hold Water for more than 3 seconds. If you press and hold the button again for more than 3 seconds, the dispenser lock will be deactivated.

### **02 Cubed Ice**

**Cubed Ice** : Press Cubed Ice to dispense cubed ice. The corresponding indicator turns on.

### **03 Crushed Ice**

**Crushed Ice** : Press Crushed Ice to dispense crushed ice. The corresponding indicator turns on.

## **Special features**

The refrigerator features user-oriented devices that you can use to benefit from.

### **Water/Ice dispenser (applicable models only)**

Using the dispenser, you can dispense water with or without ice. The water dispenser offers 3 options: chilled water, cubed ice, and crushed ice. To dispense chilled water, press Water on the dispenser panel. Put a water glass under the dispenser, and then push the dispenser lever.

To dispense water with ice

1. With the Ice Maker enabled, press Cubed Ice or Crushed Ice to select the ice type.
2. Put a water glass under the dispenser, and then push the dispenser lever with the glass. Ice will be dispensed from the dispenser.
3. Press Water to select water.
4. Push the dispenser lever with the glass. Water will be dispensed from the dispenser.

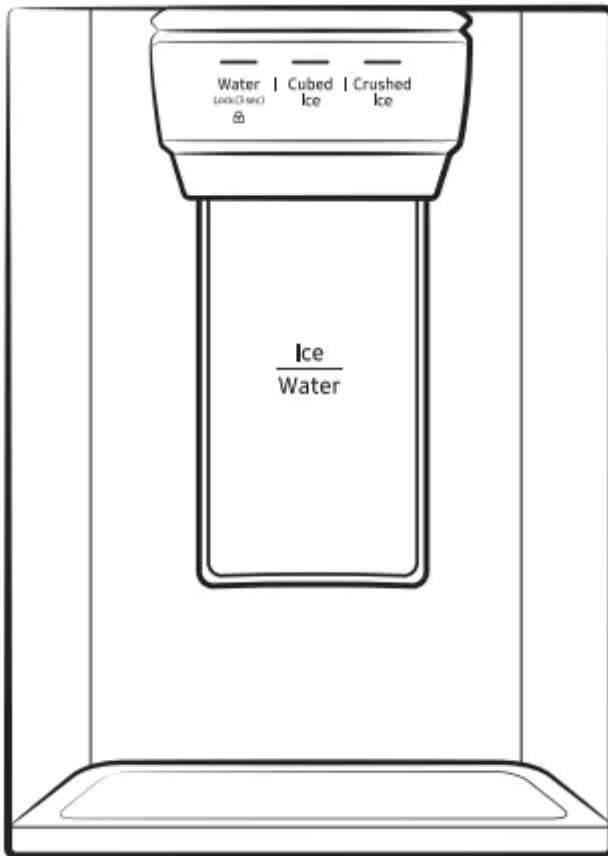

### **Ice maker (applicable models only)**

The refrigerator has a built-in ice maker that automatically dispenses ice so that you can enjoy filtered water with cubed or crushed ice.

#### Ice making

After you have installed your refrigerator and plugged it in, follow these instructions to ensure proper ice making and to keep the ice bucket full of ice:

1. Let the refrigerator operate for at least 24 hours to ensure optimal performance.
2. Dispense the first 4 to 6 ice cubes into a glass.
3. Wait another 8 hours and dispense another 4 to 6 ice cubes.

4. Then, wait another 16 hours and dispense the first glass-full of ice.

**To fill the water tank (applicable models only)**

For first-time use, clean the inner side of the water tank and dry well.

1. Hold both handgrips on the front of the tank, and slide out as shown.

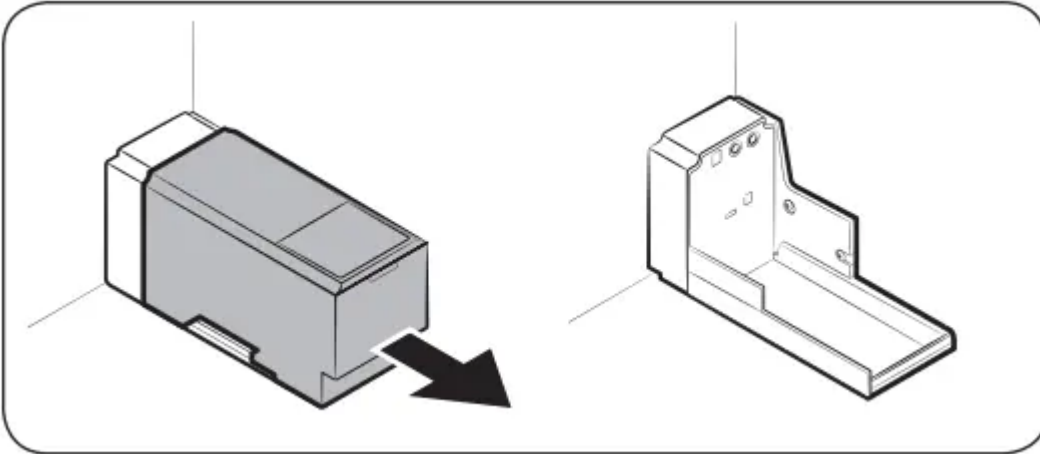

2. Open the front lid (A) of the cover or the entire cover (B) and fill the tank with a max of 5 litres water.

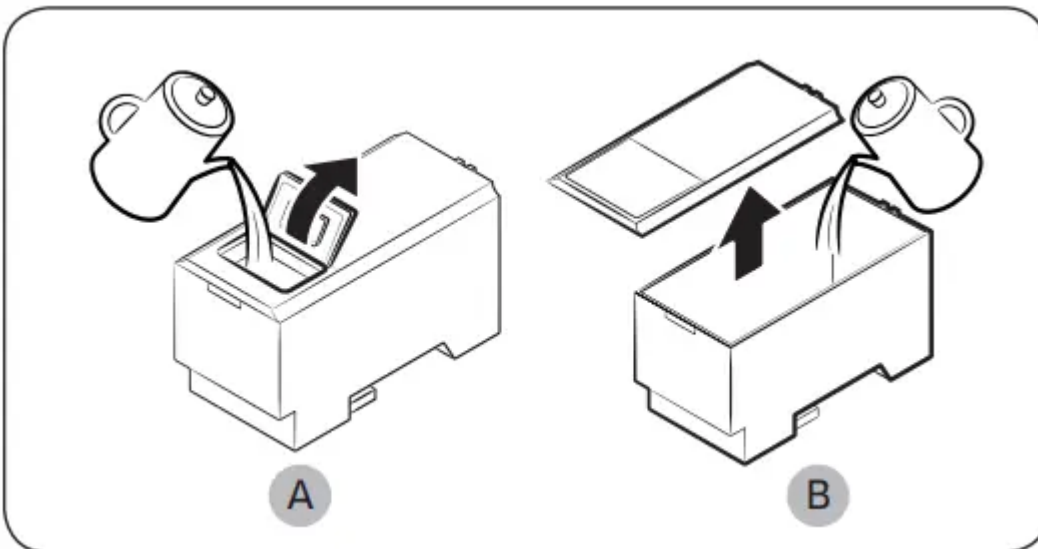

3. Reinsert the water tank and fit into the dispenser mechanism. Make sure the front side (with the front lid) of the tank faces to the front.

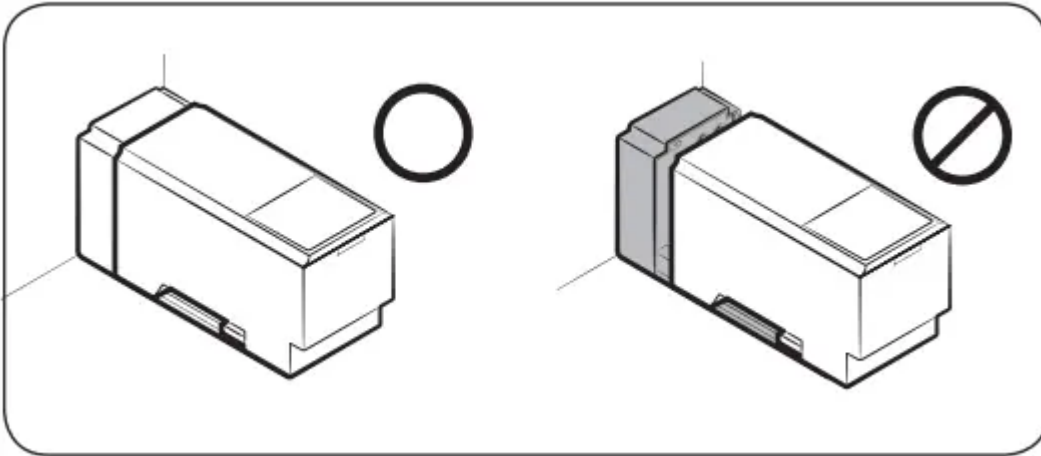

**CAUTION :**

- Make sure the water tank fits into the shelf. Otherwise, the water tank may not operate properly.
- Do not use the refrigerator without inserting the water tank. This may decrease the cooling performance.
- Fill the tank only with potable water such as mineral or purified water. Do not use other liquid.
- Use caution when moving a filled tank. Physical injury may occur if the tank is dropped.
- Do not try to disassemble the internal pump yourself. If the internal pump is damaged or disconnected from the water tank, the dispenser does not operate.

**For first-time use**

- Push the dispenser lever for 10 seconds to emit air from the hoses of the water supply system.
- Discard the first six glasses of water to remove impurities in the water supply system.

**Ice making (applicable models only)**

The refrigerator has a built-in ice maker that automatically dispenses ice so that you can enjoy filtered water with cubed or crushed ice to your preference.

If ice does not dispense, first check the ice maker if it makes ice properly.

To check the ice maker

1. Gently hold the icemaker bucket (B) with both hands and remove it from the ice chute (A).

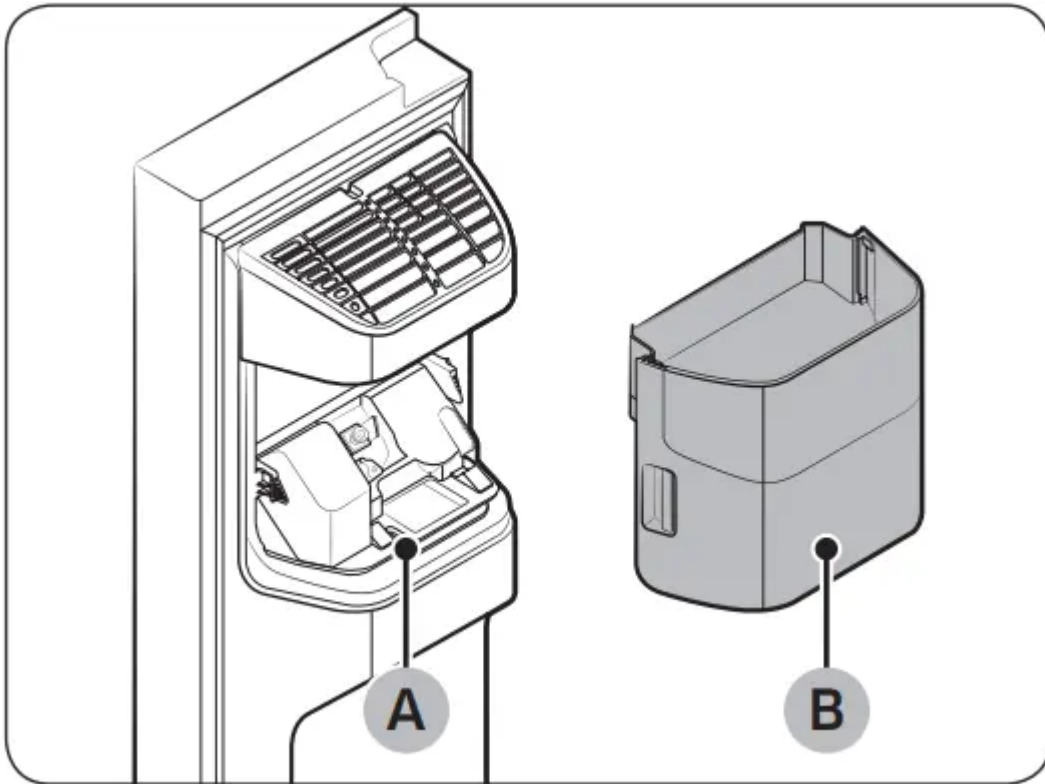

2. Check the icemaker bucket if it contains ice as appropriate.

3. Press the button (C) on the bottom of the ice maker. You will hear a chime (ding-dong) at the press of the button.

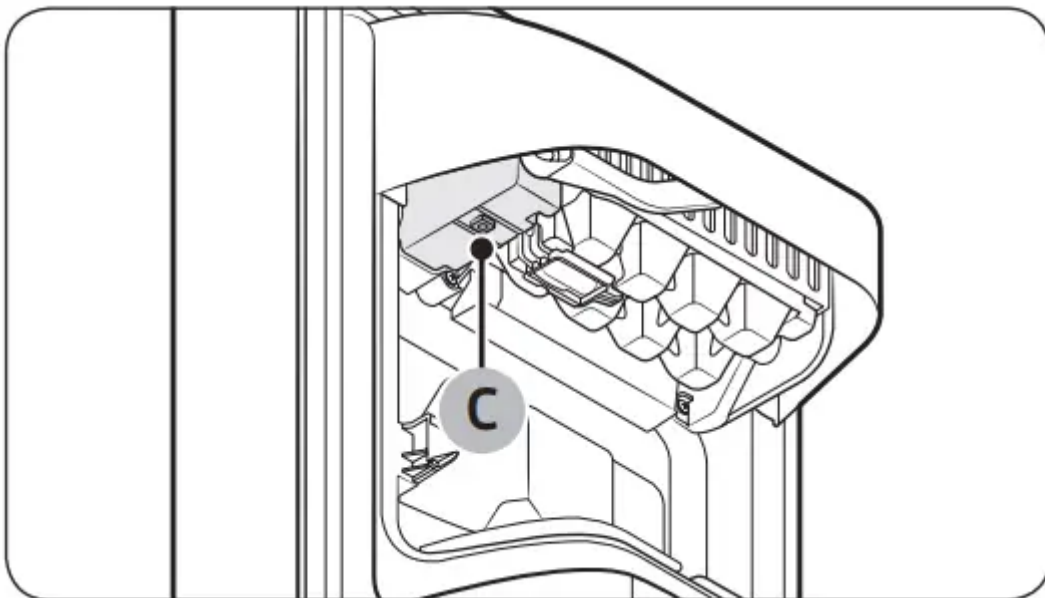

4. You will hear another chime if the ice maker operates properly.

**To secure more storage space (applicable models only)**

If you do not use the ice maker and need more storage space, remove the icemaker bucket (A). Then, insert the Freezer guide (Optional) (B) into the icemaker bucket's place.

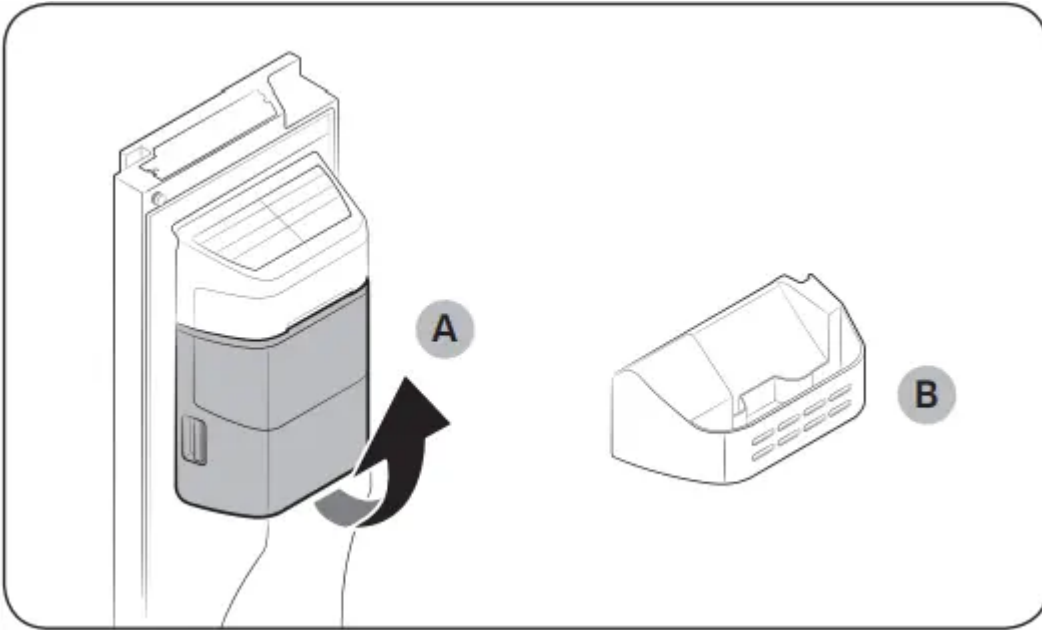

To secure more space, remove the upper drawer (C), lower drawer (D), and lower drawer cover (E). Then, insert the provided bottom shelf (F)

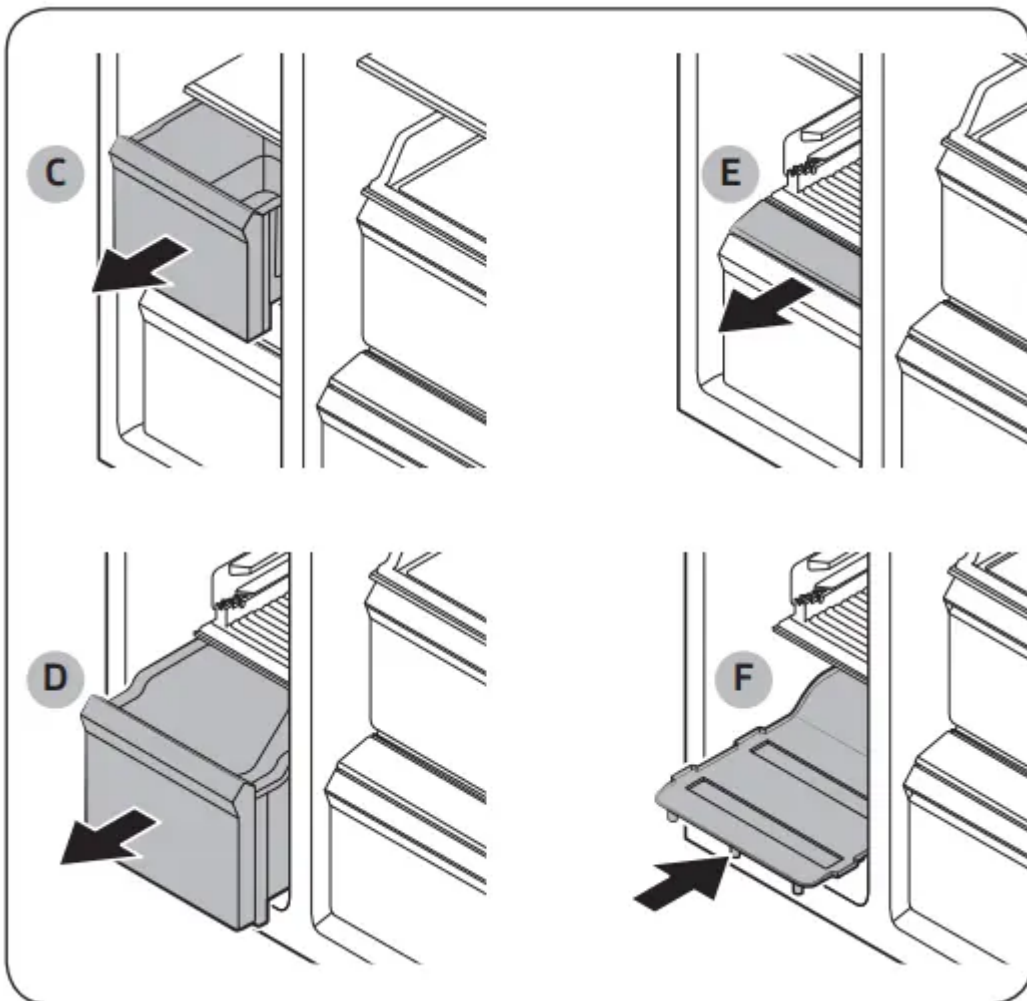

For more space, remove the water tank and use the space to store more items.

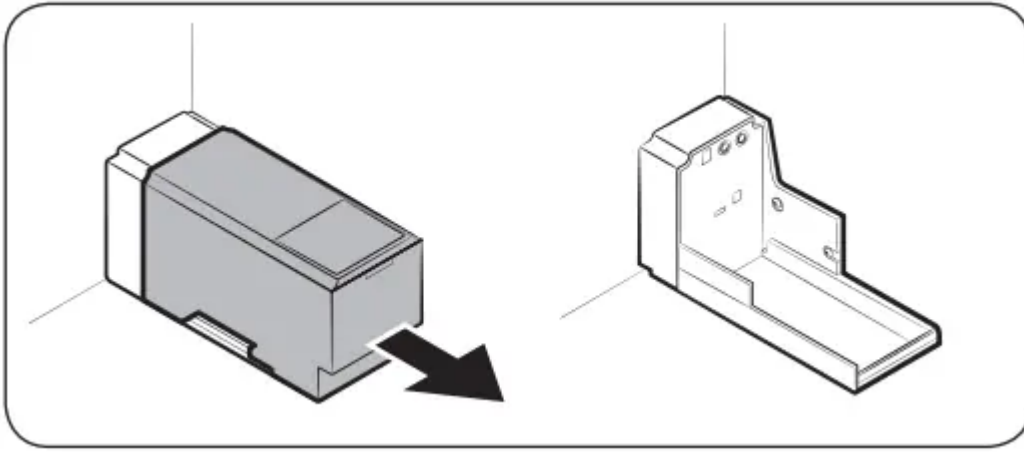

If you do not use the ice maker and need more storage space, remove the icemaker bucket (G). Then, insert the Freezer guide (Optional) (H) on the ice chute.

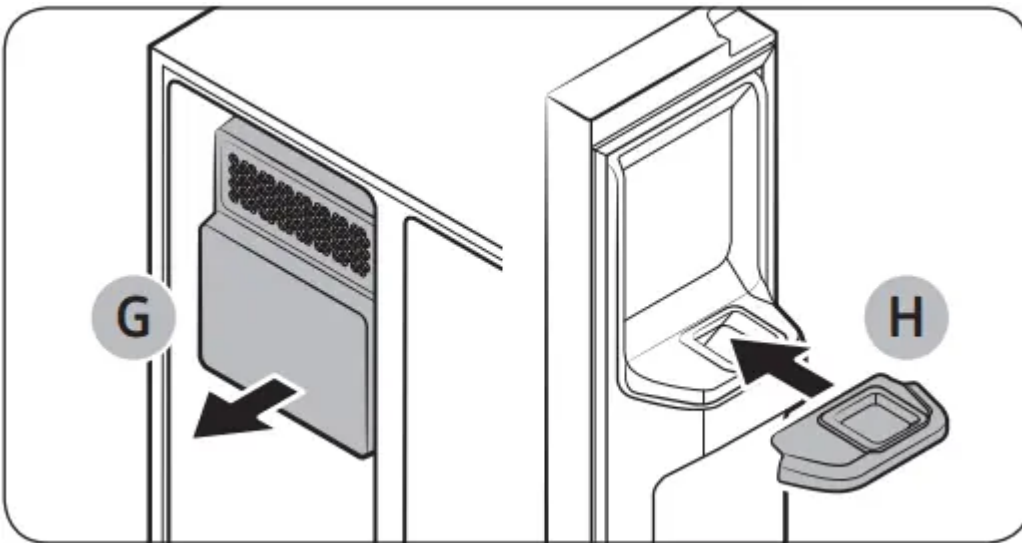

### Icemaker bucket

If you do not dispense ice for an extended period, ice may form clumps inside the bucket. If this happens, remove and empty the icemaker bucket.

1. To remove the icemaker bucket, gently lift it up and pull out slowly while holding the handgrips with both hands
2. Remove and empty the icemaker bucket.
3. When done, turn the gear handle on the rear of the bucket by 90°, and then put the bucket back into position. Make sure the bucket is inserted properly until you hear a clicking sound.
4. Press and hold Ice Maker for 3 seconds to reset the ice maker

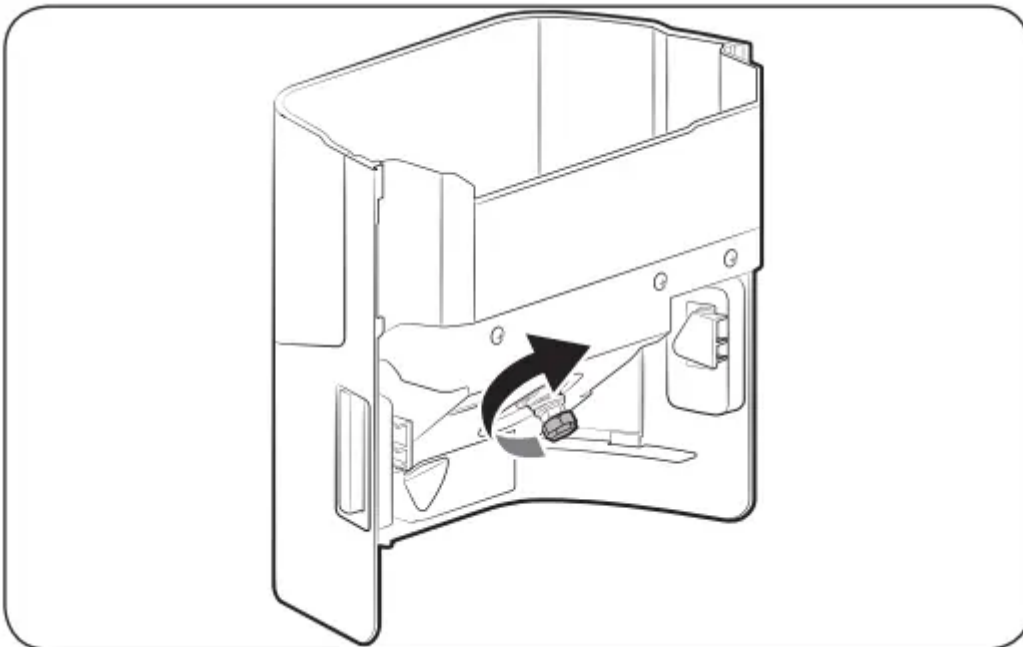
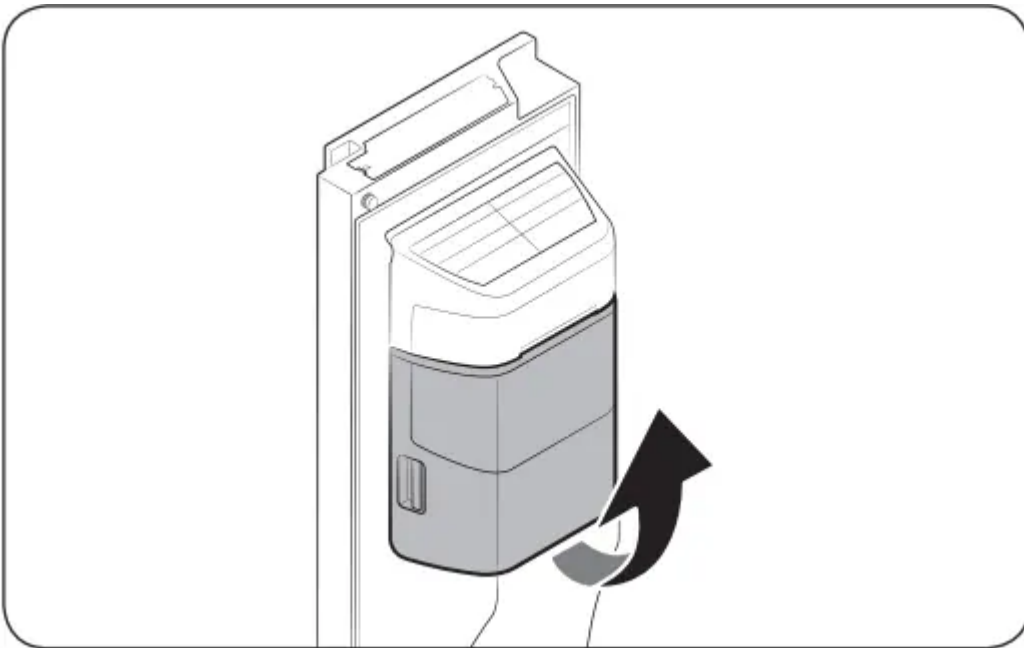

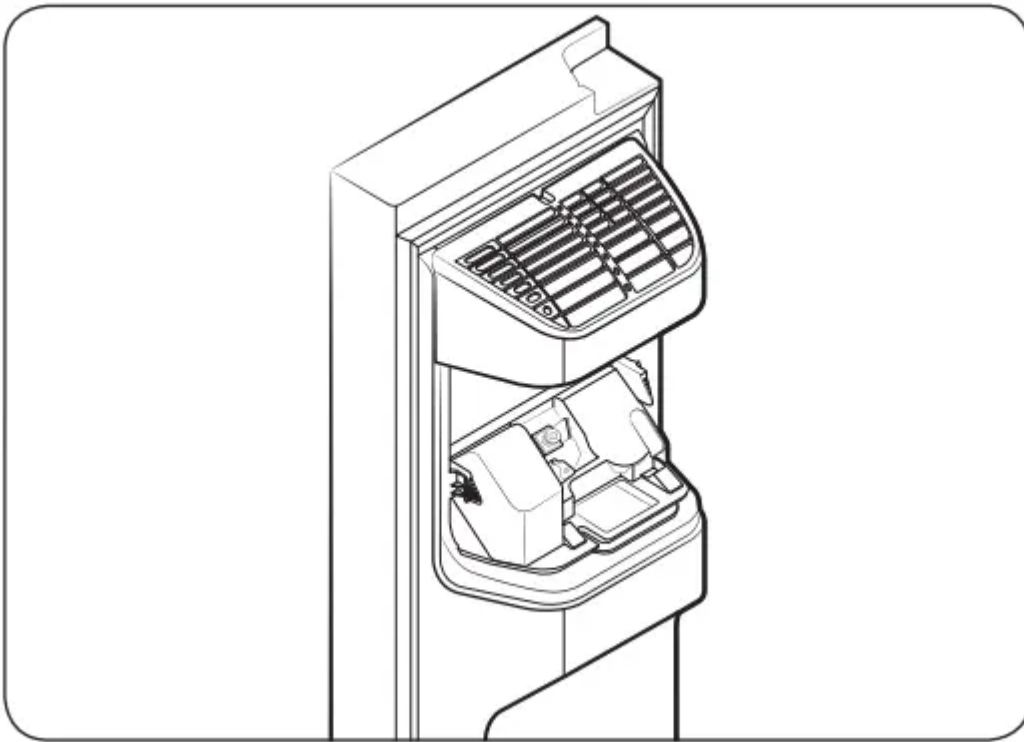

### **Water pressure**

If you want to check how much water flows into the ice tray, follow these steps.

1. Remove the ice bucket.
2. Press the button (A) on the bottom of the ice maker. Normally, the ice tray fills with water in a few minutes.
3. If the water level is lower than expected, check the water pressure of the water supply line from the water source. This is not a system failure

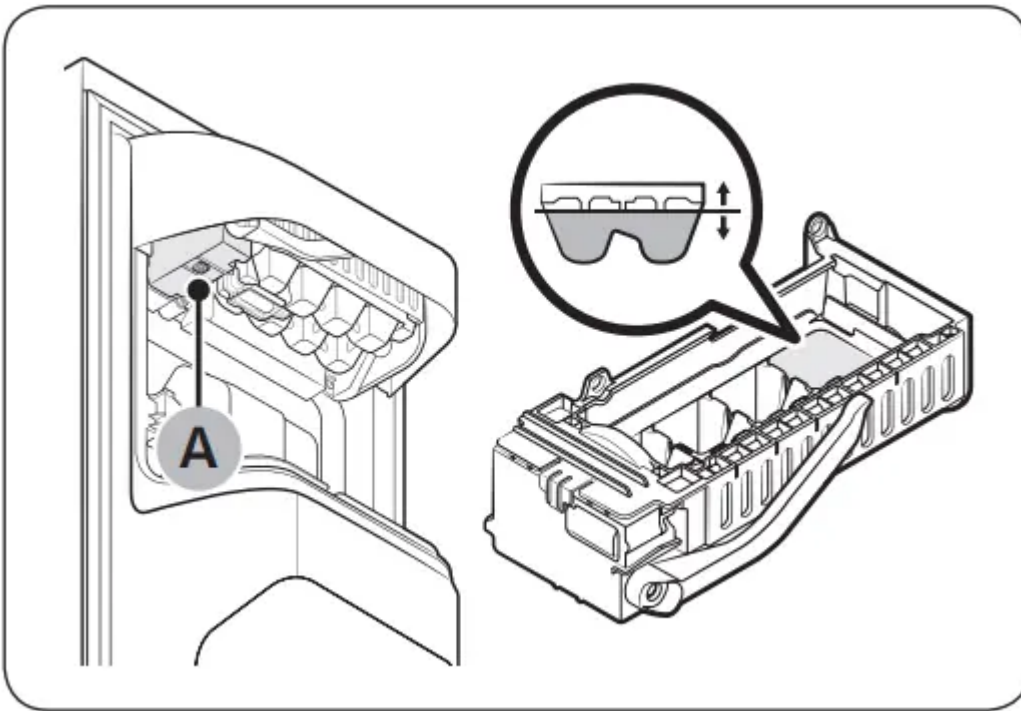

## Maintenance

### Handle and care

#### Shelves (fridge/freezer)

- To remove a shelf, fully open the corresponding door. Hold the front of the shelf and gently lift up and slide out.
- If the door cannot fully open, slide out the shelf half way to the front and turn it over to remove.

#### CAUTION

- The shelf must be inserted correctly. Do not insert upside down.
- Glass containers may scratch the surface of glass shelves.
- Do not insert a shelf in the wine rack position. This may damage the refrigerator. (applicable models only)

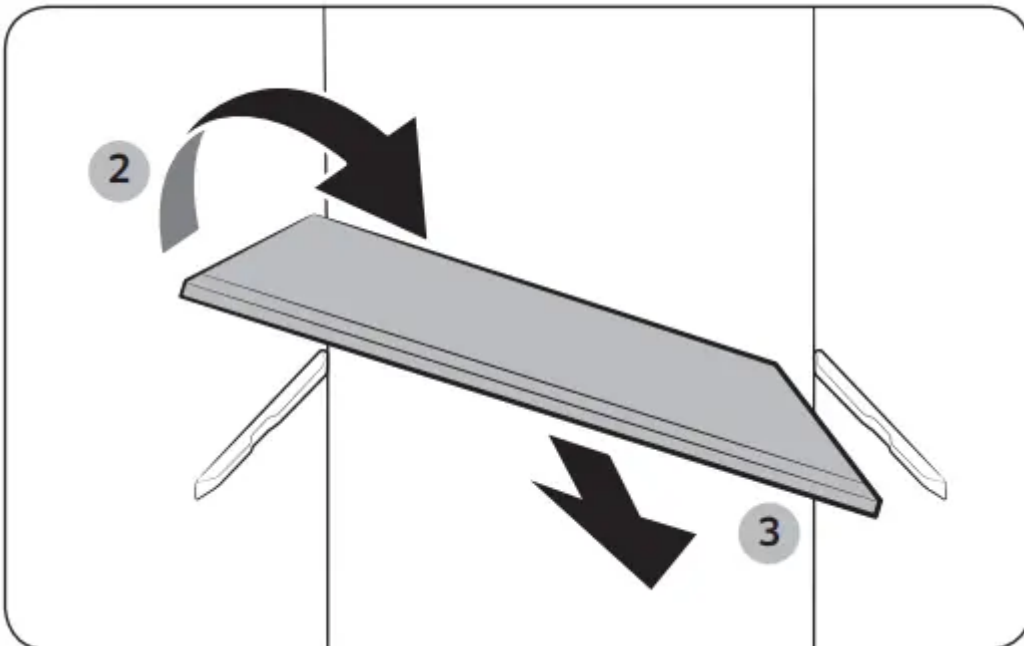
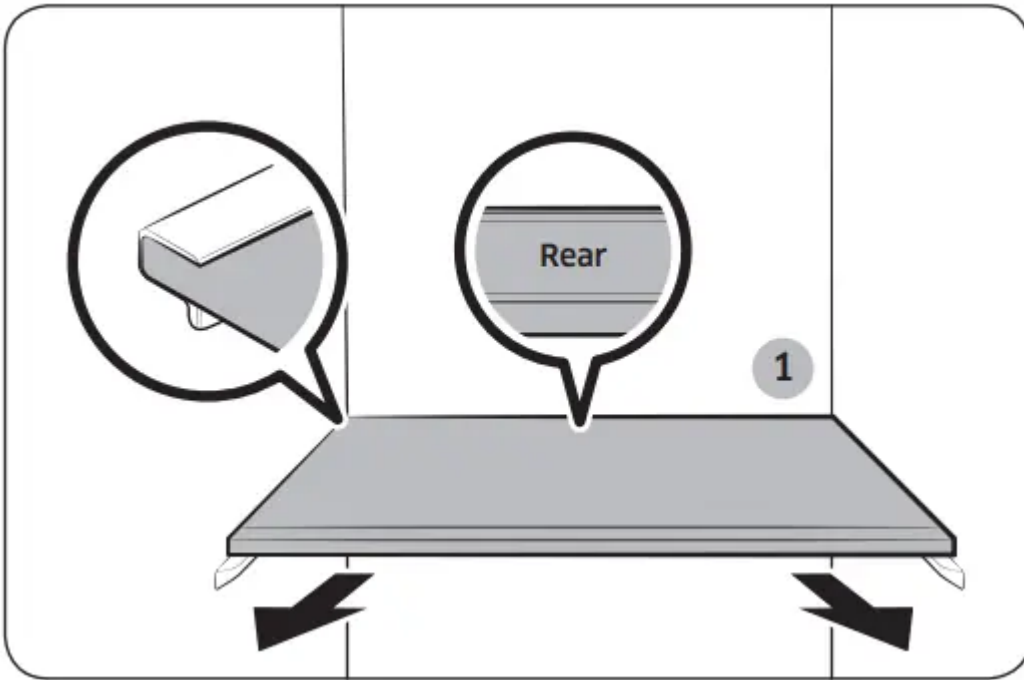

**Door bins**

To remove a door bin, hold the front sides of the bin and gently lift up to remove



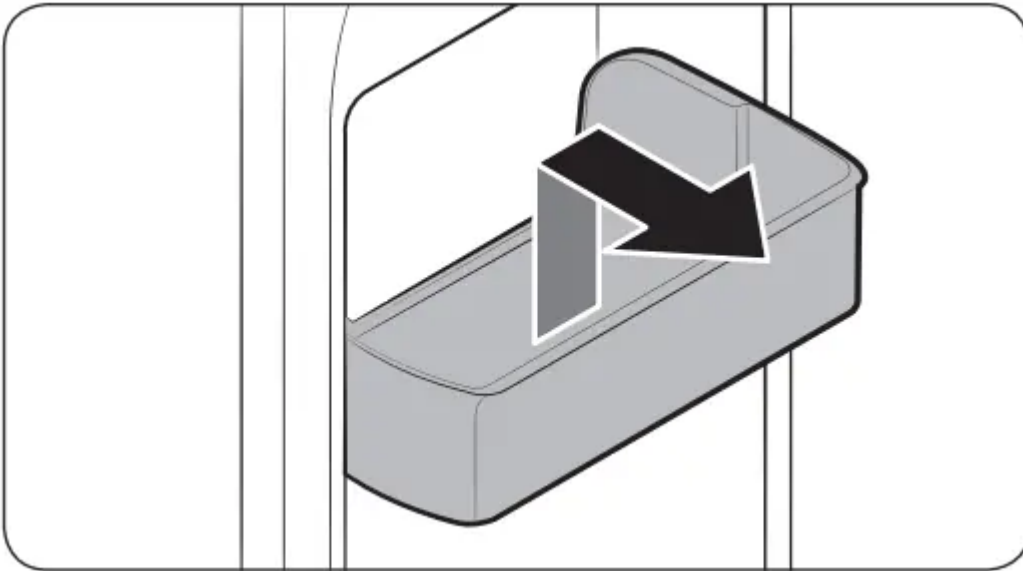

### **Drawers**

Gently lift up the front of the drawer and slide out.

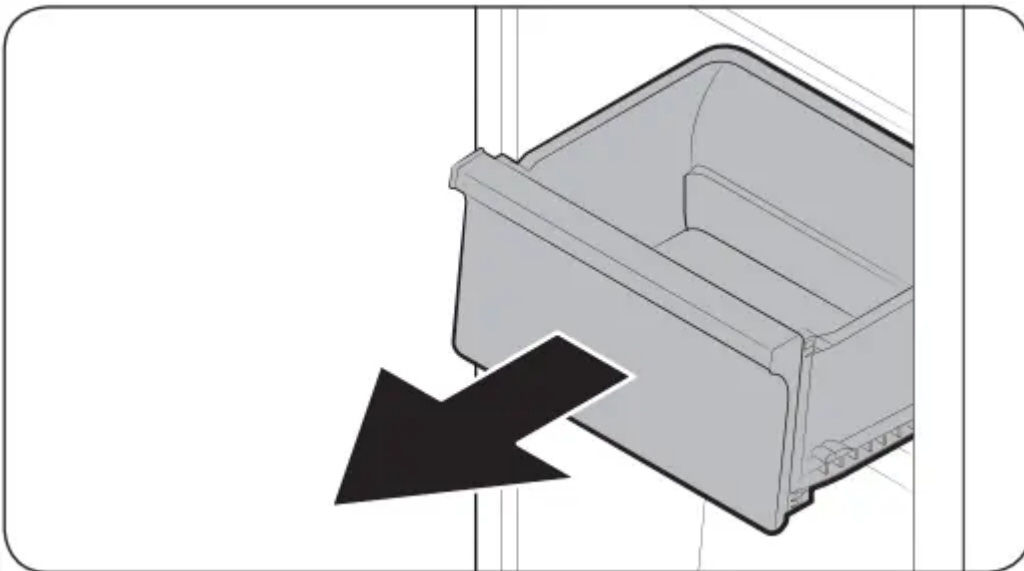

### **Vegetable / Dry drawers**

To remove the vegetable drawer from the fridge or the dry drawer from the freezer.

1. First, remove surrounding multipurpose drawers if necessary.
2. If your refrigerator is provided with a cover (A) for the vegetable/dry drawer, remove the cover. For this, slide out the cover while holding down the clips on either side of the cover.
3. Gently pull out the vegetable/dry drawer.

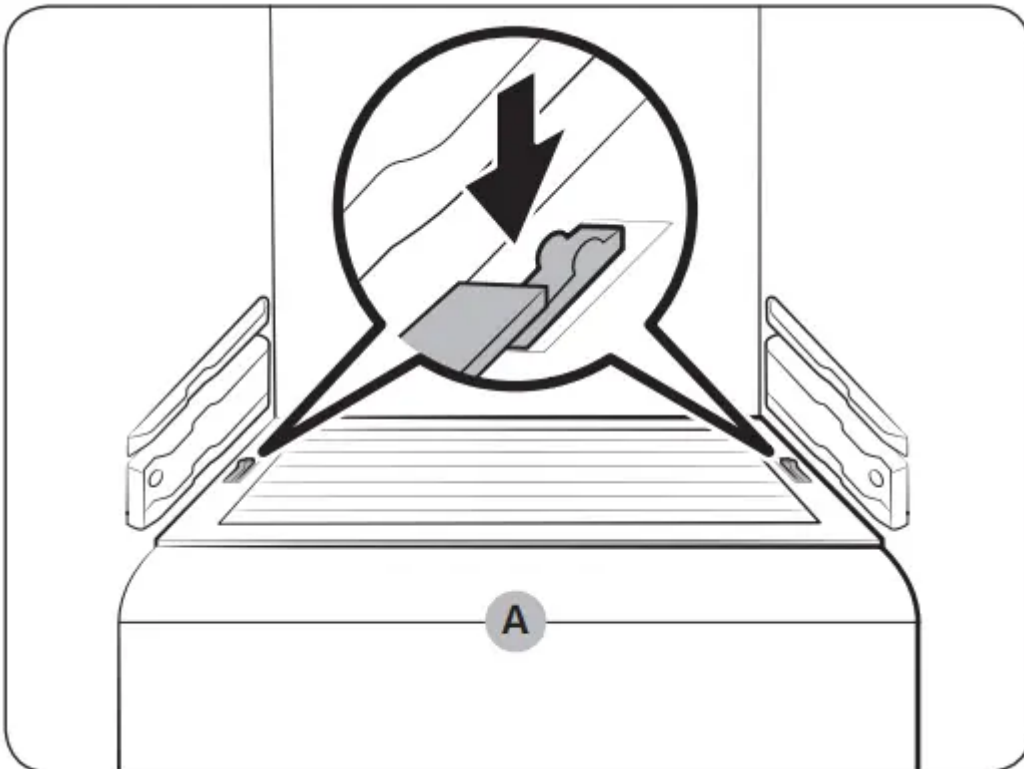
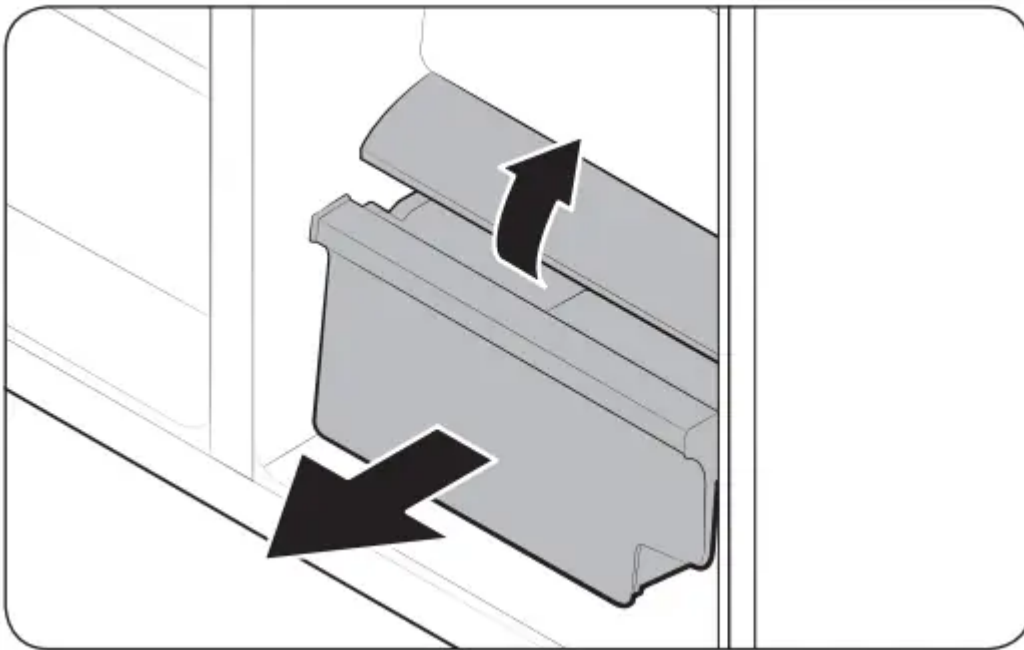

### **Icemaker bucket**

To remove the ice maker bucket, see the Icemaker bucket section on page 62.

### **Cleaning**

#### **Interior and exterior**

Regularly use a dry cloth to remove all foreign substances such as dust or water from the power plug terminals and contact points.

1. Unplug the power cord.

2. Use a moistened, soft, lint-free cloth or paper towel to clean the refrigerator's interior and exterior.
3. When done, use a dry cloth or paper towel to dry well.
4. Plug in the power cord.

### **Ice / Water dispenser (applicable models only)**

NOTE : For hygienic purposes, frequently clean the dispenser area.

CAUTION : When crushed ice is selected, some residual ice chips may collect in the ice chute. To prevent this, remove the residual ice from the chute using a soft, clean cloth.

### **Rubber seals**

If the rubber seals of a door become dirty, the door may not close properly and reducing refrigerator performance and efficiency. Use a mild detergent and damp cloth to clean the rubber seals. Then, dry well with a cloth.

### **Rear panel**

To keep cords and exposed parts of the rear panel free of dirt, vacuum the panel once or twice a year.

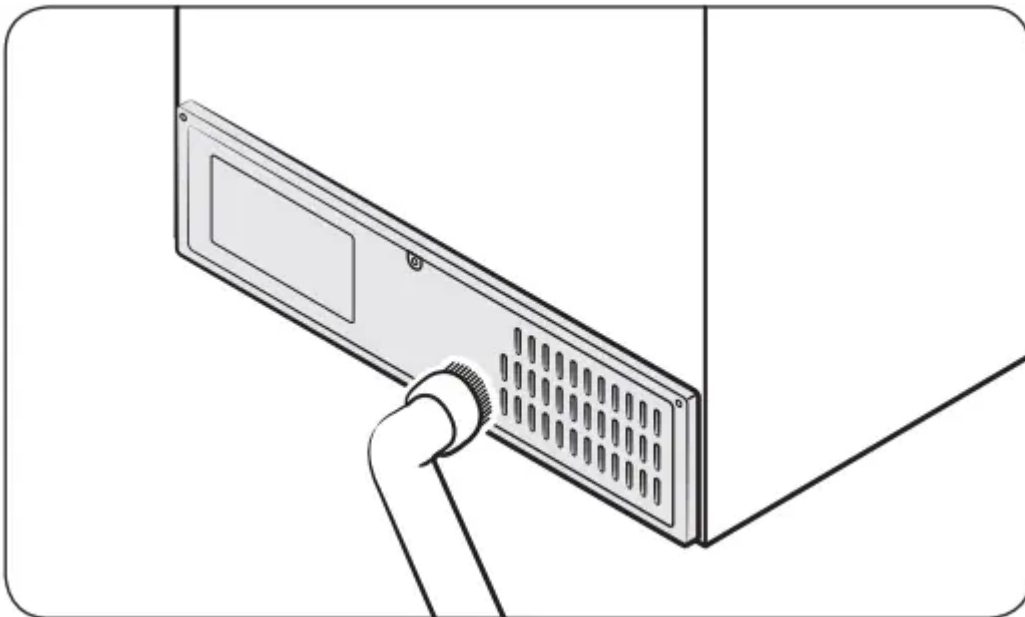

### **Replacement**

#### **Lamps**

The lamps are not user-serviceable. To replace the lamps of the refrigerator, contact a local Samsung service center.

# Troubleshooting

## General

### Temperature

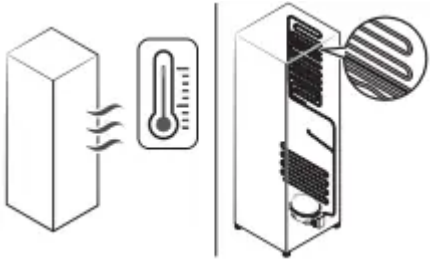

Symptom	Possible causes	Solution
Fridge/freezer does not operate. Fridge/freezer temperature is warm.	Power cord is not plugged in properly.	Properly plug in the power cord.
	Temperature control is not set correctly	Set the temperature lower.
	Refrigerator is located near a heat source or direct sunlight.	Keep the refrigerator away from direct sunlight or a heat source.
	Not enough clearance between refrigerator and nearby walls or cabinets.	We recommend that the gap between the refrigerator and nearby walls (or cabinets) is more than 50 mm.
	The refrigerator is overloaded. Food is blocking the refrigerator vents.	Do not overload the refrigerator. Do not allow food to block vents.
Fridge/freezer is over-cooling.	Temperature control is not set correctly.	Set the temperature higher
Interior wall is hot.	Refrigerator has heat-proof piping in the interior wall.	<p>To prevent condensation from forming, the refrigerator has heat-proof piping in the front corners. If the ambient temperature rises, this equipment may not work effectively. This is not a system failure.</p> 

## Odour

Symptom	Possible causes	Solution
Refrigerator has odours.	Spoiled food.	Clean the refrigerator and remove any spoiled food.
	Food with strong odours	Make sure strong smelling food is wrapped airtight.

### Frost

Symptom	Possible causes	Solution
Frost around the vents	Food is blocking the vents.	Make sure no food blocks the refrigerator vents.
Frost on interior walls.	Door is not closed properly.	Make sure food does not block the door. Clean the door gasket.

### Condensation

Symptom	Possible causes	Solution
Condensation forms on the interior walls.	If door is left open, moisture enters the refrigerator.	Remove the moisture and do not leave a door open for extended periods of time.
	Food with high moisture content.	Make sure food is wrapped airtight.

### Water/ice (dispenser models only)

Symptom	Possible causes	Solution
Water flow is weaker than normal.	Water pressure is too low.	Make sure the water pressure is between 20 to 120 psi
Ice maker makes a buzzing sound.	The ice maker function is activated, but the water supply to the refrigerator has not been connected.	Turn off the Ice maker.
Ice maker does not make ice.	Ice maker has just been installed.	You must wait for 12 hours for the refrigerator to make ice.
	Freezer temperature is too high	Set the freezer temperature below -18 °C (0 °F) or -20 °C (-4 °F) in warm ambient air.
	Dispenser panel Lock is activated.	Deactivate dispenser panel Lock.
	Ice maker is off	Turn on the ice maker.
	Ice may jam if the ice dispenser is not used for a long time (approx. 3 weeks).	If you won't be using the refrigerator for a long time, empty the ice bucket and turn off the ice maker
	Ice bucket is not properly inserted	Make sure the ice bucket is properly inserted.
	Water line is not connected properly or water supply is not on.	Check if the water line is installed correctly. Check if the water line stop cock is closed.  
Water does not dispense.	Water line is not connected properly or water supply is not on.	Check if the water line is installed correctly. Check if the water line stop cock is closed.

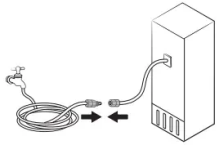
		
Dispenser panel Lock is activated.		Deactivate dispenser panel Lock.
A third-party water filter was installed.		<ul style="list-style-type: none"> <li>• Use only Samsung-provided or approved filters.</li> <li>• Unapproved filters may leak and damage the refrigerator</li> </ul>

### Do you hear abnormal sounds from the refrigerator?

Before calling for service, review the checkpoints below. Any service calls related to normal sounds will be charged to the user.

#### These sounds are normal.

- When starting or ending an operation, the refrigerator may make sounds similar to a car engine igniting. As the operation stabilizes, the sounds will decrease.

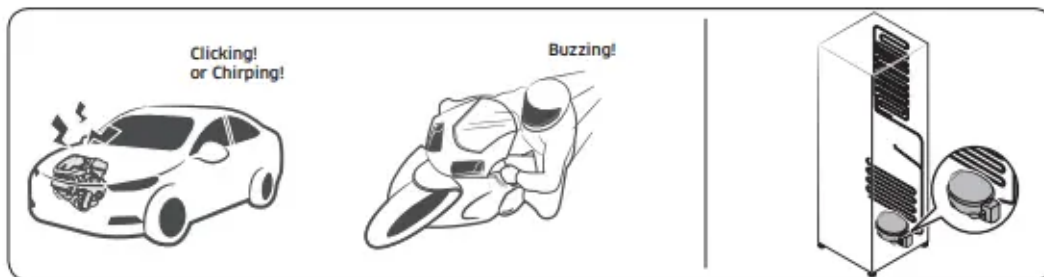

- While the fan is operating, these sounds may occur. When the refrigerator reaches the set temperature, no fan sound will occur.



- During a defrost cycle, water may drip on the defrost heater, causing sizzling sounds.

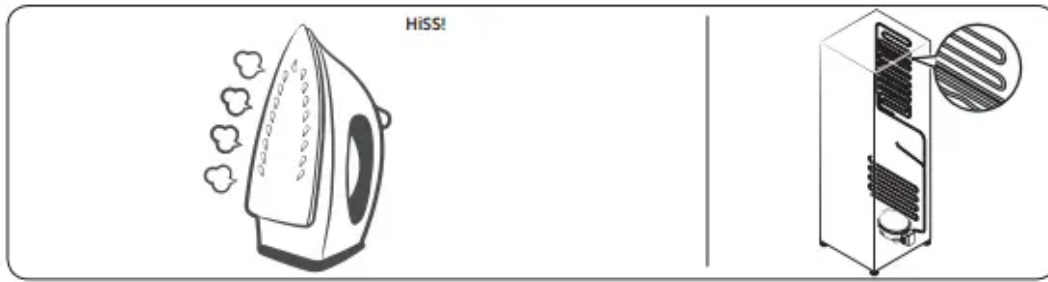

- As the refrigerator cools or freezes, refrigerant gas moves through sealed pipes, causing bubbling sounds.

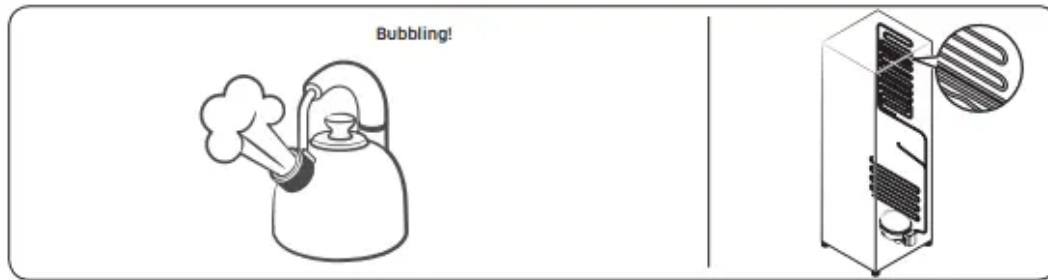

- As the refrigerator temperature increases or decreases, plastic parts contract and expand, creating knocking noises. These noises occur during the defrosting cycle or when electronic parts are working.

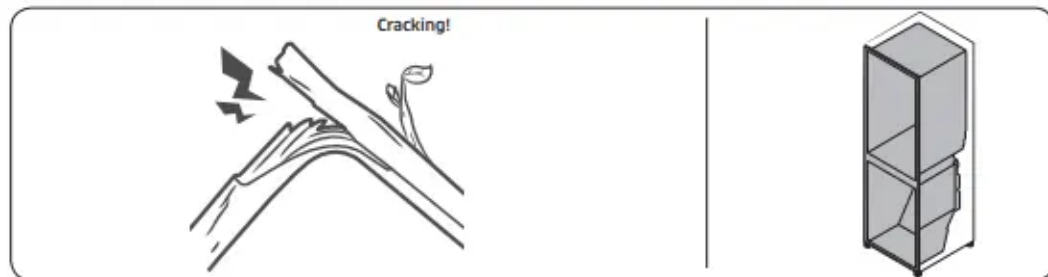

- For ice maker models: When the water valve opens to fill the ice maker, buzzing sounds may occur.
- Due to pressure equalizing when opening and closing the refrigerator door, whooshing sounds may occur

## SmartThings

Symptom	Action
Could not find “SmartThings” in the app market.	<ul style="list-style-type: none"> <li>• The SmartThings app is designed for Android 6.0 (Marshmallow) or later, iOS 10.0 or later, iPhone 6 or later, and is optimized for Samsung smartphones (Galaxy S and Galaxy Note series).</li> </ul>
The SmartThings app fails to operate.	<ul style="list-style-type: none"> <li>• The SmartThings app is available for applicable models only.</li> <li>• The old Samsung Smart Refrigerator app cannot connect with SmartThings models.</li> </ul>
The SmartThings app is installed but is not connected to my refrigerator.	<ul style="list-style-type: none"> <li>• You must log into your Samsung account to use the app.</li> <li>• Make sure that your router is operating normally.</li> <li>• Make sure that the Smart Home Adapter is inserted properly.</li> <li>• If the Wi-Fi icon on the refrigerator’s display is off, this indicates that no network connection has been established yet. In this case, use the SmartThings app to connect and register your refrigerator to the access point (AP/Router) in your home</li> </ul>
Could not log into the app.	<ul style="list-style-type: none"> <li>• You must log into your Samsung account to use the app.</li> <li>• If you don’t have a Samsung account, follow the app’s onscreen instructions to create one.</li> </ul>
An information message appears when I try to register my refrigerator.	<ul style="list-style-type: none"> <li>• Network connection may fail due to the distance from your access point (AP) or electrical interference from the surrounding environment. Wait a moment and try again.</li> </ul>
The SmartThings app is successfully connected to my refrigerator but does not run.	<ul style="list-style-type: none"> <li>• Exit and restart the SmartThings app or disconnect and reconnect the router. • Remove the Smart Home Adapter, and reconnect it properly. Then, try again.</li> </ul>

**Warning**



This content is compiled from multiple sources and is provided for reference purposes only. It may not be complete or fully applicable to all situations. If you are unable to resolve your issue, please contact the product manufacturer or an authorized service provider for official support.

---

Document generated by [ManualsFile](#)

