

What's included

Make sure all the parts are included in the product package. If you have a problem with the washing machine or the parts, contact a local Samsung customer centre or the retailer.

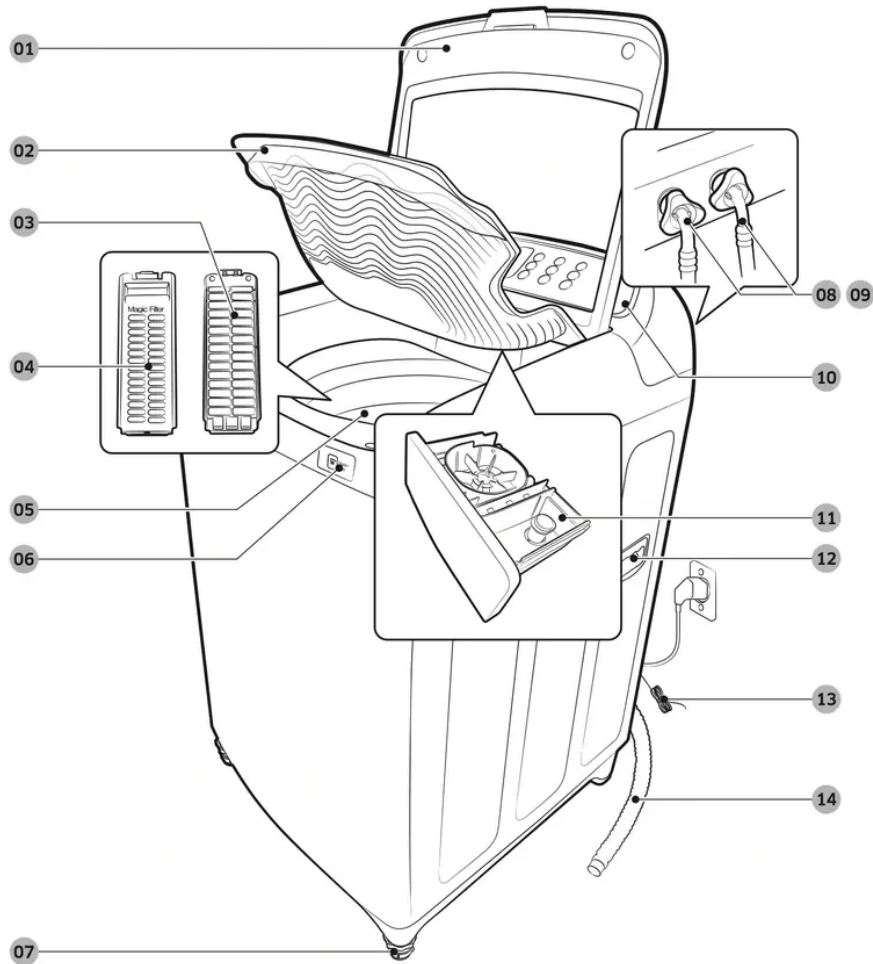

1. Door
2. Built-in sink
3. Lint filter (Rear)
4. Lint filter (Front)
5. Tub
6. Water Jet
7. Levelling feet
8. Water hose (Cold)
9. Water hose (Hot) *
10. Control panel

11. Detergent drawer
12. Side handle *
13. Grounding lead *
14. Drain hose





NOTE

- Availability of parts with an asterisk (*) depends on the model.
- Door: Make sure to keep the door closed while the washing machine is operating.
- Lint filter: This collects lint that builds up from the laundry being washed.
- Grounding lead: Cover this lead if wired to a metal part for earth-grounding.
- Levelling feet: Adjust the feet to level the washing machine on a flat floor.

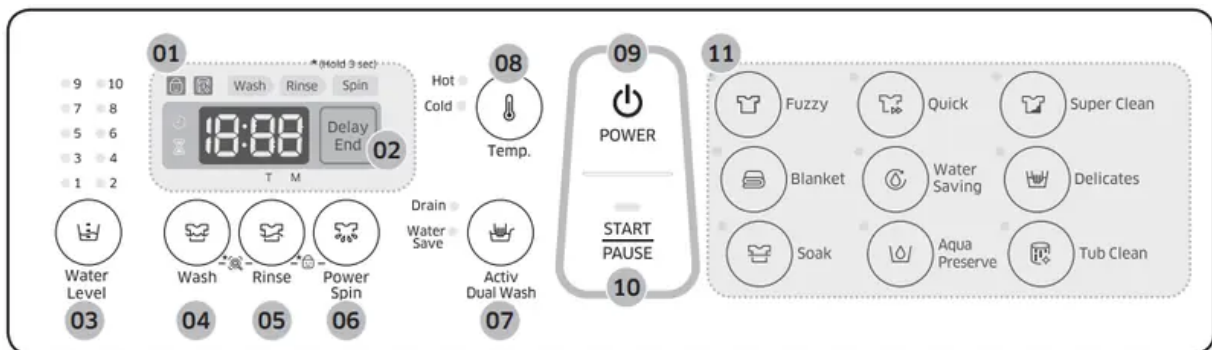
Operations

Control panel



<p>01 Display</p>	<p>Displays the remaining time of a cycle, or the information code when a problem occurs.</p> <p> Child Lock</p> <p>Child Lock is used to prevent children from accidents such as drowning in the tub, and remains active after the machine restarts. To cancel the Child Lock, deactivate it.</p> <p> Tub Clean</p> <p>Use to keep the tub clean. This indicator lights up automatically on a regular basis. When the indicator turns on, run the Tub Clean cycle.</p> <p> Delay End</p> <p>You can set to finish a cycle at a specific time. This indicator turns on when pressing Delay End and turns off when the set cycle starts.</p> <p> Status</p> <p>After selecting a cycle, press Delay End or Start/Pause. This indicator turns on and displays the remaining time of the current cycle.</p>
<p>02 Delay End</p>	<p>Press this button to finish the wash at a specified time.</p> <p>To cancel the Delay End settings, simply turn off the washing machine.</p> <p>You can set the Delay End time up to 19 hours.</p>
<p>03 Water Level</p>	<p>The water level is adjusted according to the cycle. However, you can change the level manually.</p>
<p>04 Wash</p>	<p>Press to start washing, or adjust the wash time between 6 and 30 minutes.</p>
<p>05 Rinse</p>	<p>Press to run the rinse cycle, or change the rinse count up to 5.</p>

06 Power Spin	Press to run the spin cycle, or change the spinning time in this sequence: 1-9 min (increase by 1 minute) > 15 min > 30 min.
07 Activ Dual Wash	<p>This button provides two options, and is available only when the washing machine is stopped or in Standby state.</p> <ul style="list-style-type: none"> •Water Save (default): Select to reuse water in the tub that remains after using Water Jet. The water will be used for the main cycle. •Drain: Select to drain water that remains after using Water Jet. When draining is complete, the washing machine switches to Water Save mode automatically. Then, you can choose a cycle.
08 Temperature	Press to select a temperature level from 3 choices: Cold > Cold/Hot > Hot.
09 Power	Press once to turn the machine on, or twice to turn it off.
10 Start/Pause	Press to stop or resume operation. To change the cycle sequence, press once to stop operation, and then change the sequence. To resume operation, press again.
11 Cycle Panel	Choose one that best suits your needs.

Simple steps to start

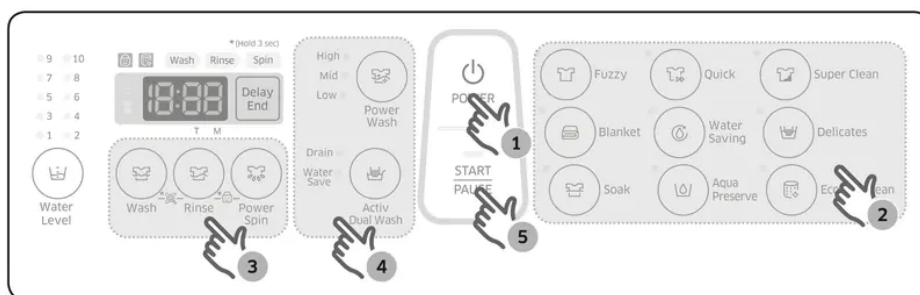

1. Press Power to turn on the washing machine.
2. Select a cycle in the cycle panel.
3. Change the cycle settings (wash time, rinse count, and/or spinning time) as necessary.
4. To add an option such as Power Wash, Magic Wash and Activ Dual Wash, press the corresponding button.
5. Press Start/Pause.

To change the cycle during operation

1. Press Start/Pause to stop operation.
2. Select a different cycle, and repeat steps 2-3 above if necessary.
3. Press Start/Pause again to start the new cycle.

Auto cycles

Cycle	Description
Fuzzy	<ul style="list-style-type: none"> •Select this for most fabrics including cottons, liners, and averagely soiled garments.
Quick	<ul style="list-style-type: none"> •Select this for less soiled clothes in reduced time.
Super Clean	<ul style="list-style-type: none"> •Select this if you want to produce powerful cleaning performance.
Blanket	<ul style="list-style-type: none"> •Suitable for a large-sized laundry such as blankets and bed cover sheets.
Water Saving	<ul style="list-style-type: none"> •Select this to wash effectively with a minimum amount of water. •For WA85J6750S*, “Water Saving, Water level 10, Cold/Hot” is recommended for a normally soiled cotton load. •Energy and water labelling test programme in accordance with AS/NZS 2040.
Delicates	<ul style="list-style-type: none"> •Select this for delicate items such as sweaters, cardigans, or wool clothes.
Soak	<ul style="list-style-type: none"> •With this selected, the washing machine adds a soaking process in advance of the main cycle.
Aqua Preserve	<ul style="list-style-type: none"> •Use this if you want to save the water to use. The water used in the rinse process will be reused for the next process.
Tub Clean	<ul style="list-style-type: none"> •Select this to clean the tub. The powerful spinning force will remove impurities and bad odours from inside the tub. •If you see the  indicator blinking, this indicates that it is recommended to clean the tub using Tub Clean. For details, see the Cleaning section in this manual.

Manual cycles

You might want to use a single cycle to wash less soiled clothes. For example, you can run the wash cycle once for nightwear.

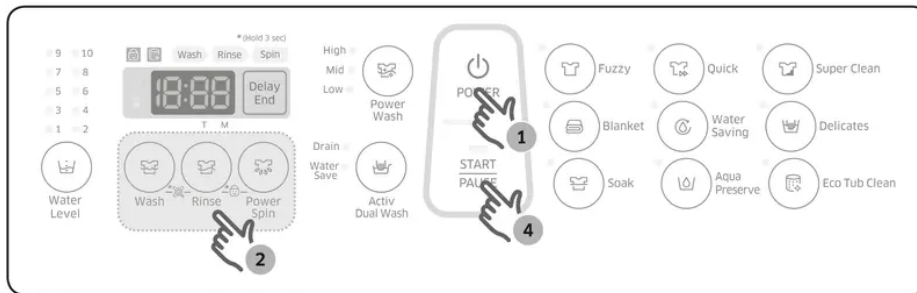

1. Press Power to turn on the washing machine.
2. Press Wash/Rinse/Power Spin to run the individual cycle to your needs. The duration or count of each cycle can be adjusted by pressing the applicable button as many times as needed.

Wash time	Rinse count	Power Spin time
6-30 minutes	1-5 times	1-9, 15, 30 minutes

3. If you want to run a combination of cycles, press applicable cycle buttons as below:

Wash + Rinse	Rinse + Spin	Wash + Rinse + Power Spin
Rinsing after washing	Spinning after rinsing	Washing, rinsing, and then spinning in sequence

4. Press Start/Pause.

Maintenance

Cleaning

Keep the washing machine clean to prevent deteriorated performance and to preserve its life cycle.

Eco Tub Clean reminder

-  The indicator reminds you of cleaning the tub when necessary. If you happen to see the indicator blinking after washing is complete, remove the laundry and run the Eco Tub Clean cycle.
- You can ignore this reminder and continue to run cycles normally because this is not a system failure. However, the reminder remains active for 6 consecutive cycles immediately after each cycle is complete.
- The reminder is activated once every 1-3 months, depending on the cycle count.
- To keep the tub clean, it is recommended to run Eco Tub Clean on a regular basis.

Built-in sink

1. Open the door, and use a cloth or sponge to clean the Built-in sink.
2. Press Water Jet to supply water to the board. Use this water to rinse the board.

Lint filter

1. Press down the upper area of the filter case to remove.
2. Unlock the cover, and clean the filter with running water and a brush.

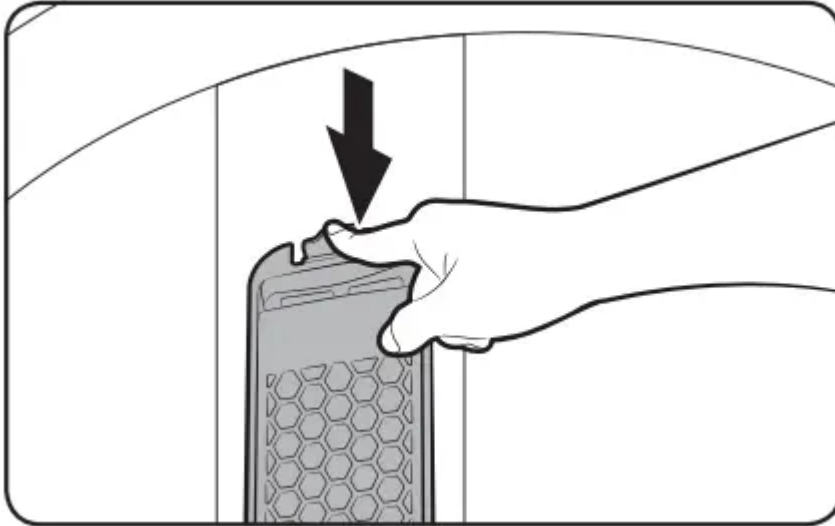

3. When cleaning is complete, close the cover and reinsert the filter case to the original position. You will hear a clicking sound when the filter case fits in.

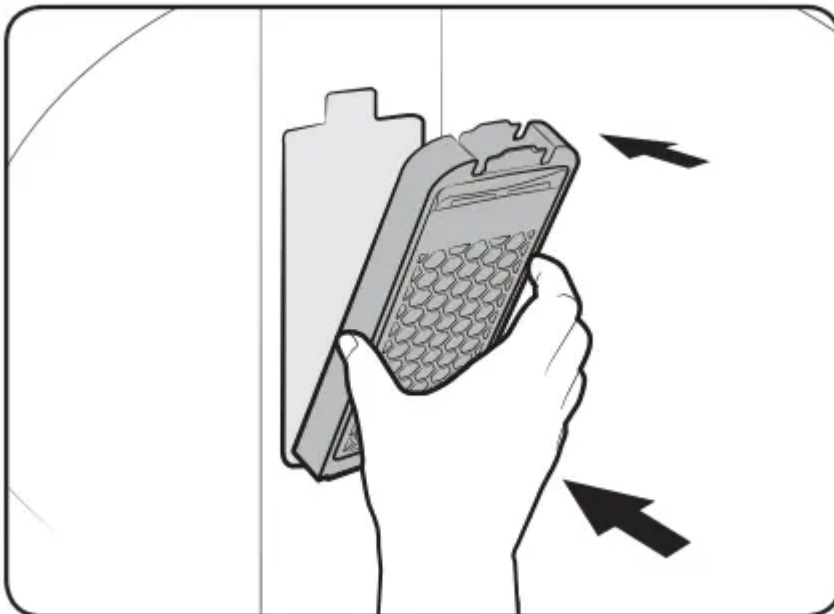

Pump filter (applicable models only)

1. Put a floor-cloth or towel under the Pump filter. Turn the filter knob anticlockwise to remove.

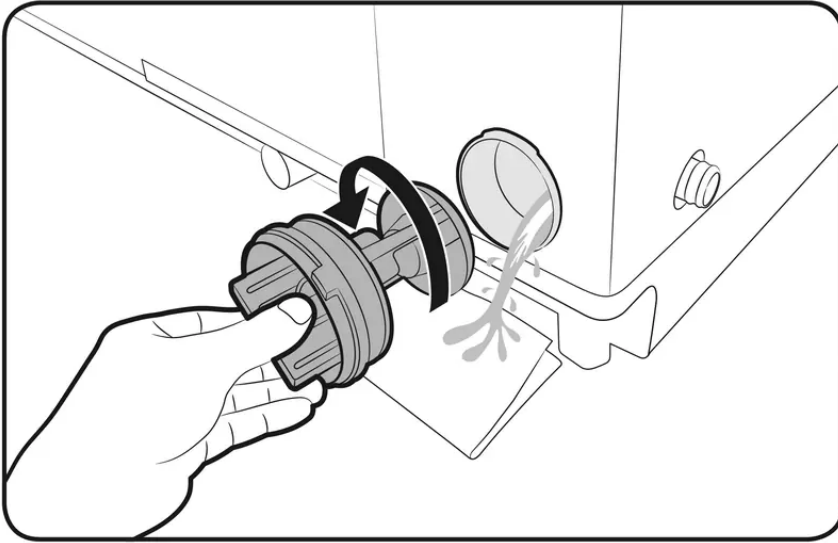

2. Clean the filter with running water and a soft brush.

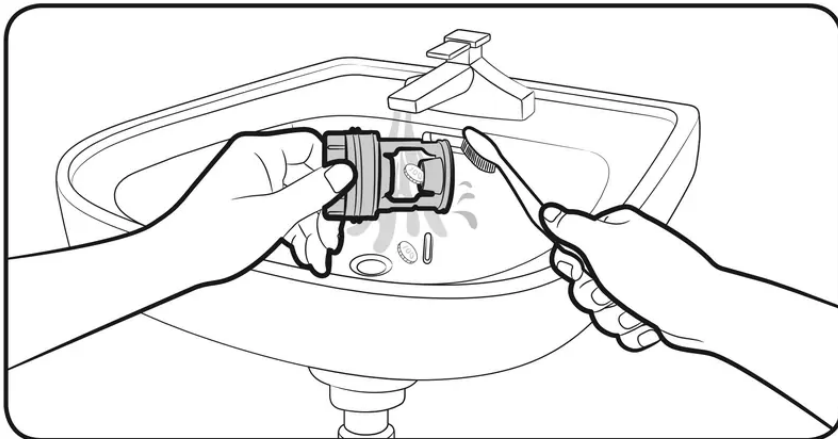

3. Reinsert the filter, and turn clockwise until it locks into position.

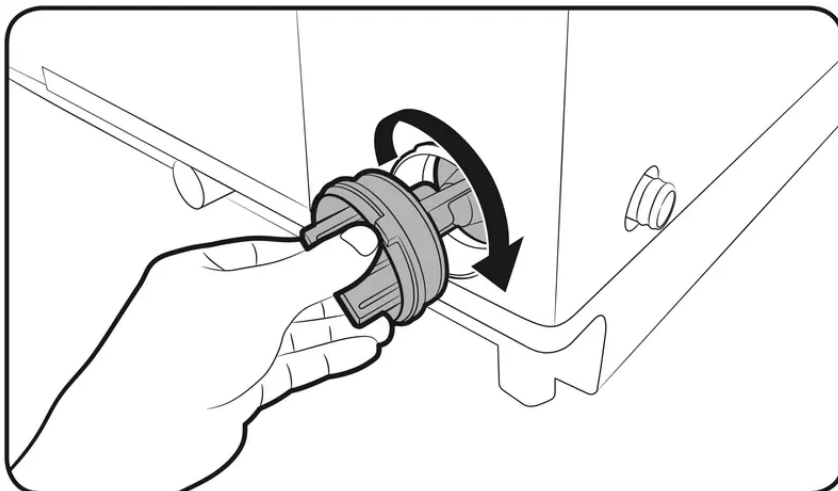

Mesh filter

1. Use pliers to pull out the mesh filter from inside the water inlet as shown.
2. Use a soft brush to clean the filter with running water.

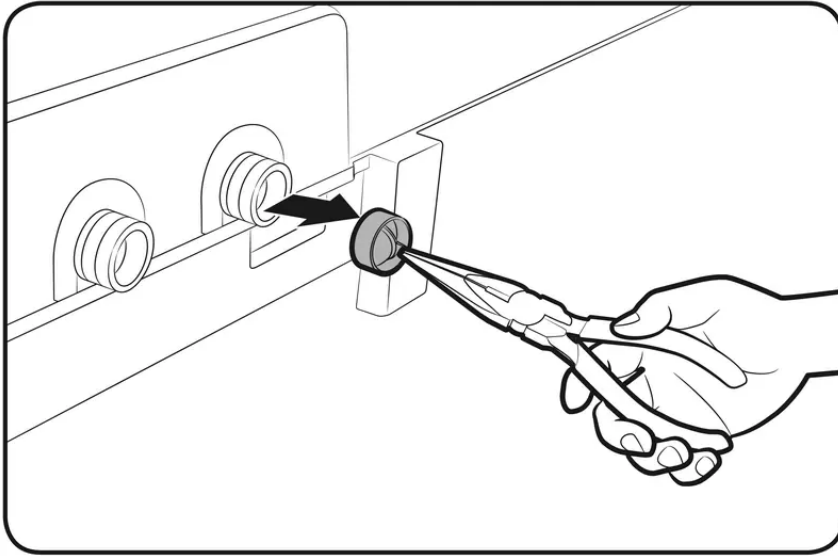

3. Reinsert the filter. Make sure it is tightened against water leaks.

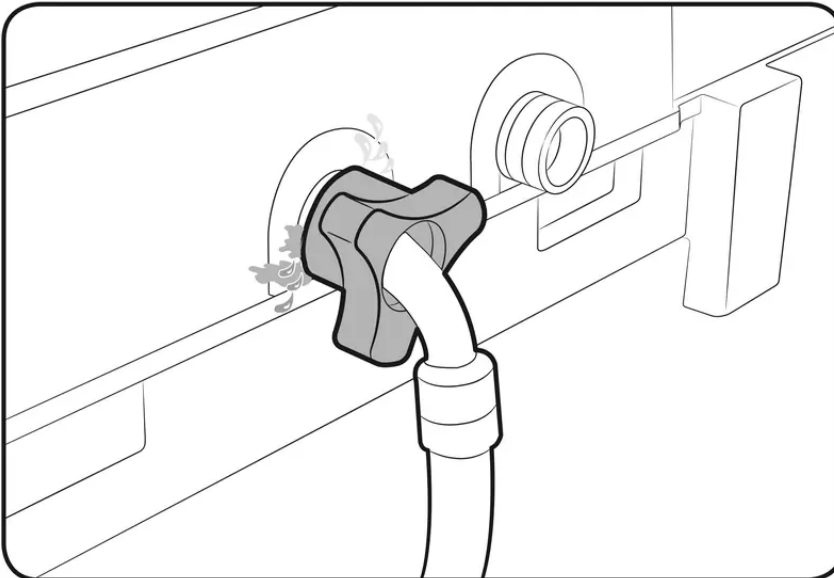
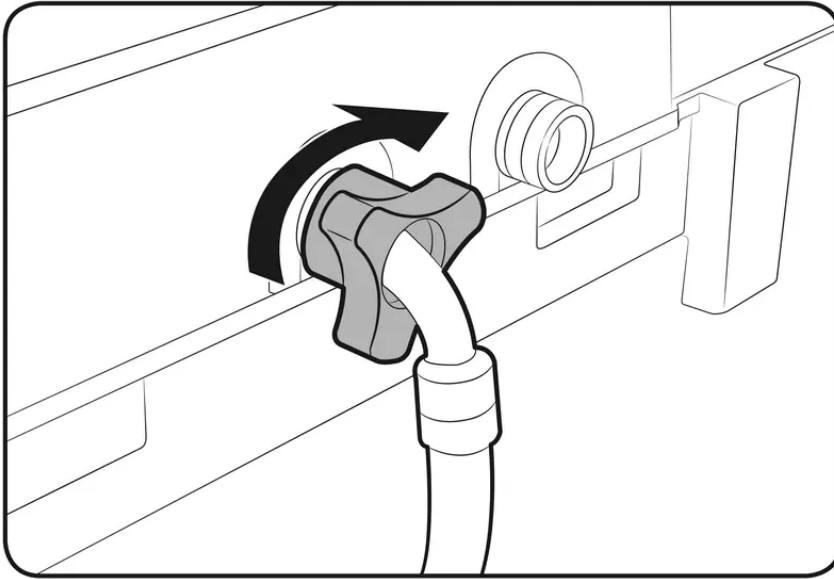

Detergent drawer

1. Open the door and then the Built-in sink to reveal the detergent drawer.
2. Slightly lift up the front edge of the drawer, and then slide it open.

3. Remove the wing distributor (A) and rinse cap (B) from the drawer.

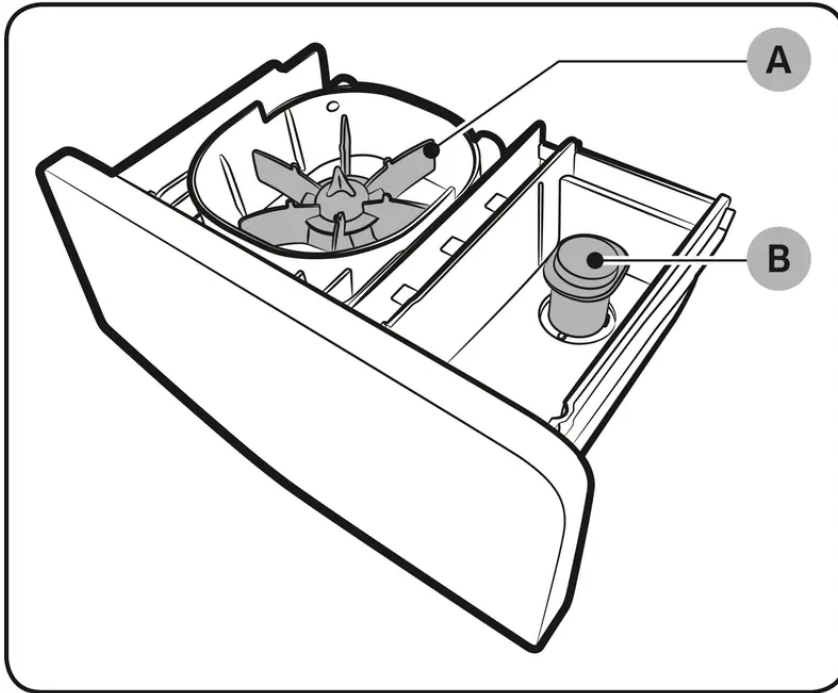

4. Clean the drawer as well as the distributor and rinse cap with running water and a soft brush.

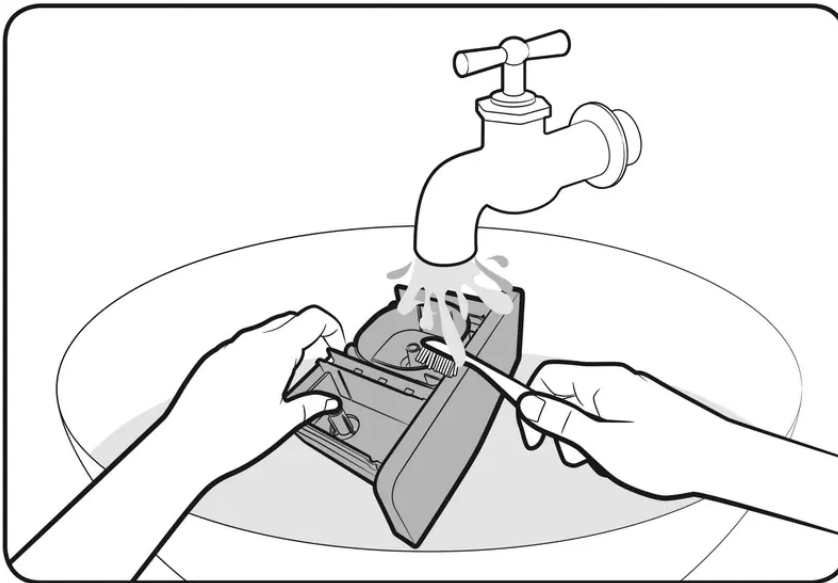

5. When complete, close the rinse cap and reinsert the distributor. Then, reinsert the detergent drawer.

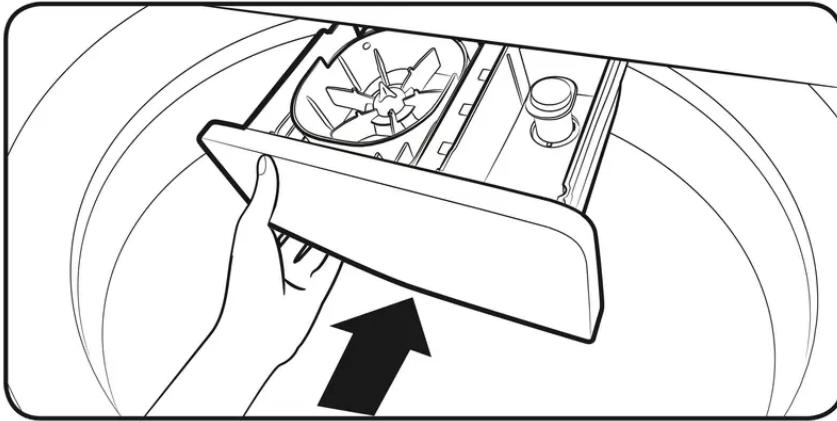

Troubleshooting

Checkpoints

If you encounter a problem with the washing machine, first check the table below and try the suggestions.

Problem	Action
Does not turn on.	<ul style="list-style-type: none"> • Make sure you use rated power for the product. • Make sure the power cord is completely plugged in. • Check the fuse or reset the circuit breaker.
Does not start.	<ul style="list-style-type: none"> • Make sure the door is closed. • Make sure the water taps are open. • Make sure to press or tap Start/Pause to start the washing machine. • Make sure Child Lock is not activated. • Before the washing machine starts to fill, it will make a series of clicking noises to check the dooropen and does a quick drain. • Was the door opened during the spinning cycle? Close the door, and press or tap Start/Pause to resume. • The machine enters Standby or is in a soaking cycle. Please wait. • Check the fuse or reset the circuit breaker.
Water is not supplied.	<ul style="list-style-type: none"> • Make sure you press or tap Start/Pause after selecting the water supply. • Make sure the water taps are open. • Is the filter net at the water supply hose connector clogged? Clean the filter net by brushing with a toothbrush. • Is the water supply cut off? If the water supply is cut off, close the tap and power off. • Straighten the water supply hoses. • Open and close the door, then press or tap Start/Pause. • If the water pressure is low, it takes longer to start washing.

	<ul style="list-style-type: none"> • If the water level is not as high as necessary or lower than expected, use the level selector to adjust the water level.
<p>After a cycle, detergent remains in the automatic dispenser.</p>	<ul style="list-style-type: none"> • Make sure the washing machine is running with sufficient water pressure. • Make sure the detergent drawer is properly inserted. • Remove and clean the detergent drawer, and then try again.
<p>Vibrates excessively or makes noise.</p>	<ul style="list-style-type: none"> • Make sure the washing machine is set on a level floor. If the floor is not level, use the levelling feet to adjust the washing machine. • Make sure the washing machine is not contacting any other object. • Make sure the laundry load is balanced. • Make sure the laundry is spread evenly in the washing machine. Spread out the laundry evenly and start again. • Make sure the space around the washing machine is free of objects. • Humming is produced normally during operation. • Objects such as coins can cause noise. Remove these objects from the washing machine after washing is complete.
<p>Stops.</p>	<ul style="list-style-type: none"> • Plug the power cord into a live electrical outlet. • Check the fuse or reset the circuit breaker. • Close the door, and press or tap Start/Pause to start the washing machine. For your safety, the washing machine will not spin unless the door is closed. • Before the washing machine starts to fill, it will make a series of clicking noises to check the door open and does a quick drain.

	<ul style="list-style-type: none"> • There may be a pause or soak period in the cycle. Wait briefly and the washing machine may start. • Make sure the inlet hose screens at the taps are not clogged. Periodically clean the screens. • This problem occurs temporarily due to low voltages, and will be solved when power recovers.
<p>Fills with the wrong temperature water.</p>	<ul style="list-style-type: none"> • Fully open both water taps. • Make sure the temperature selection is correct. • Make sure the hoses are connected to the correct water taps. Flush water lines. • Disconnect the hoses and clean the screens. The hose filter screens may be clogged. • While the washing machine fills, the water temperature may change as the automatic temperature control feature checks in coming water temperature. This is normal. • While the washing machine fills, you may notice just hot and/ or just cold water going through the dispenser when cold or warm temperatures are selected. This is a normal function of the automatic temperature control feature as the washing machine determines the water temperature.
<p>Does not drain and/ or spin.</p>	<ul style="list-style-type: none"> • Check the fuse or reset the circuit breaker. • Make sure the electrical voltage is normal. • Make sure the washing machine is plugged in. • Make sure the drain hose is pointed downward. (Natural drain models only) • Make sure the drain hose is not clogged. • Make sure the drain hose is not kinked. • Straighten the drain hose. If there is a drain restriction, call for service.



	<ul style="list-style-type: none"> • Close the door, and press or tap Start/Pause. For your safety, the washing machine will not spin unless the door is closed.
Load is wet at the end of the cycle.	<ul style="list-style-type: none"> • Use the High or Extra High spin speed. (Applicable model only) • Use high efficiency (HE) detergent to reduce oversudsing. • Load is too small. Small loads (one or two items) may become unbalanced and not spin completely.
Leaks water.	<ul style="list-style-type: none"> • Make sure all hose connections are tight. • Make sure the water supply hose's rubber packing is in the correct position. Screw tightly again. • Make sure the end of the drain hose is correctly inserted and secured to the drain system. • Avoid overloading. • Use high efficiency (HE) detergent to prevent oversudsing. • Make sure the water supply hose is not kinked. • If the water supply is too strong, water may leak. Close the water tap a little. • Make sure water is not leaking from the water tap. If so, repair the water tap.
Excessive suds.	<ul style="list-style-type: none"> • Use high efficiency (HE) detergent to prevent oversudsing. • Reduce the detergent amount for soft water, small loads, or lightly soiled loads. • Non-HE detergent is not recommended.
The spin basket or drain/supply hose is frozen.	<ul style="list-style-type: none"> • Use warm water to disconnect the water supply hose and drain hose. Soak them in warm water. • Fill the spin basket with warm water, and then wait for about 10 minutes. • Put a hot towel on the drain hose connector.



	<ul style="list-style-type: none"> • Reconnect the water supply hose and drain hose, and check if water is supplied properly.
Water drains out immediately.	<ul style="list-style-type: none"> • Make sure the drain hose is not clogged, and is hung over the drain hose hook. Fill the spin basket halfway with water, and try spinning again. • Lift the end of the drain hose to prevent water from draining. Fill the spin basket halfway with water, and then run spinning after releasing the drain hose. • Make sure the drain hose is installed correctly. See the installation section of this user manual and adjust the position of the drain hose as instructed.
Stains on clothes.	<ul style="list-style-type: none"> • Clean the magic filter.
Has odours.	<ul style="list-style-type: none"> • Excessive suds collect in recesses and can cause foul odours. • Run cleansing cycles to sanitize periodically. • Dry the washing machine interior after a cycle has finished.

Information codes

If the washing machine fails to operate, you may see an information code on the display. Check the table below and try the suggestions.

Code	Action
1C	<p>The WaterLevel sensor is not working properly.</p> <ul style="list-style-type: none"> • Check Water Level Sensor wire harness. • If the information code remains, contact a customer service centre.
3C	<p>Motor problem</p> <ul style="list-style-type: none"> • Try restarting the cycle. • If the problem continues, call for service.
4C	<p>Water is not supplied.</p> <ul style="list-style-type: none"> • Make sure the water taps are open. • Make sure the water hoses are not clogged. • Make sure the water taps are not frozen. • Make sure the washing machine is operating with sufficient water pressure. • Make sure that the cold water tap and the hot water tap are properly connected. • Clean the mesh filter as it may be clogged.
4C2	<ul style="list-style-type: none"> • Make sure the cold water supply hose is firmly connected to the cold water tap. <p>If it is connected to the hot water tap, the laundry may be deformed with some cycles.</p>
5C	<p>Water is not draining.</p> <ul style="list-style-type: none"> • Make sure the drain hose is not frozen or clogged. • Make sure the drain hose is positioned correctly, depending on the connection type. • Clean the debris filter as it may be clogged. • Make sure the drain hose is straightened all the way to the drain system. • If the information code remains, contact a customer service centre.
9C1	

	<p>Electronic Control Problem (Over Voltage Error)</p> <ul style="list-style-type: none"> • Check the PCB and wire harness. • Check if power is supplied properly. • If the information code remains, contact a customer service centre.
9C2	<p>Low voltage detected</p> <ul style="list-style-type: none"> • Check if the power cord is plugged in. • If the information code remains, contact a customer service centre.
AC6	<p>Inverter Communication problem</p> <ul style="list-style-type: none"> • Check the Inverter PCB and wire harness. • If the information code remains, contact a customer service centre.
dC	<p>Operating the washer with the door open.</p> <ul style="list-style-type: none"> • Make sure the door is properly closed. • Make sure laundry is not caught in the door.
HC	<p>Water temperature control problem (Heater control)</p> <ul style="list-style-type: none"> • If the information code remains, contact a customer service centre.
LC	<p>Check the drain hose.</p> <ul style="list-style-type: none"> • Make sure the end of the drain hose is placed on the floor. • Make sure the drain hose is not clogged. • If the information code remains, contact a customer service centre.
OC	<p>Water is overflowed.</p> <ul style="list-style-type: none"> • Restart after spinning. • If the information code remains on the display, contact a local Samsung service centre.
PC	<p>When position of the clutch can't be detected.</p> <ul style="list-style-type: none"> • If the information code remains, contact a customer service centre.
PC1	

	<p>After position of the clutch is detected, if the signal of the clutch hall goes wrong.</p> <ul style="list-style-type: none">• If the information code remains, contact a customer service centre.
Ub	<p>Spinning does not work.</p> <ul style="list-style-type: none">• Make sure laundry is spread out evenly.• Make sure the washing machine is on a flat, stable surface.• Redistribute the load. If only one item of clothing needs washing, such as a bathrobe or pair of jeans, the final spin result might be unsatisfactory, and an “Ub” check message will be shown in the display.

If any information code keeps appearing on the screen, contact a local Samsung service centre.

Warning

This content is compiled from multiple sources and is provided for reference purposes only. It may not be complete or fully applicable to all situations. If you are unable to resolve your issue, please contact the product manufacturer or an authorized service provider for official support.