

KNOW YOUR BREVILLE COMPACT SMART OVEN™

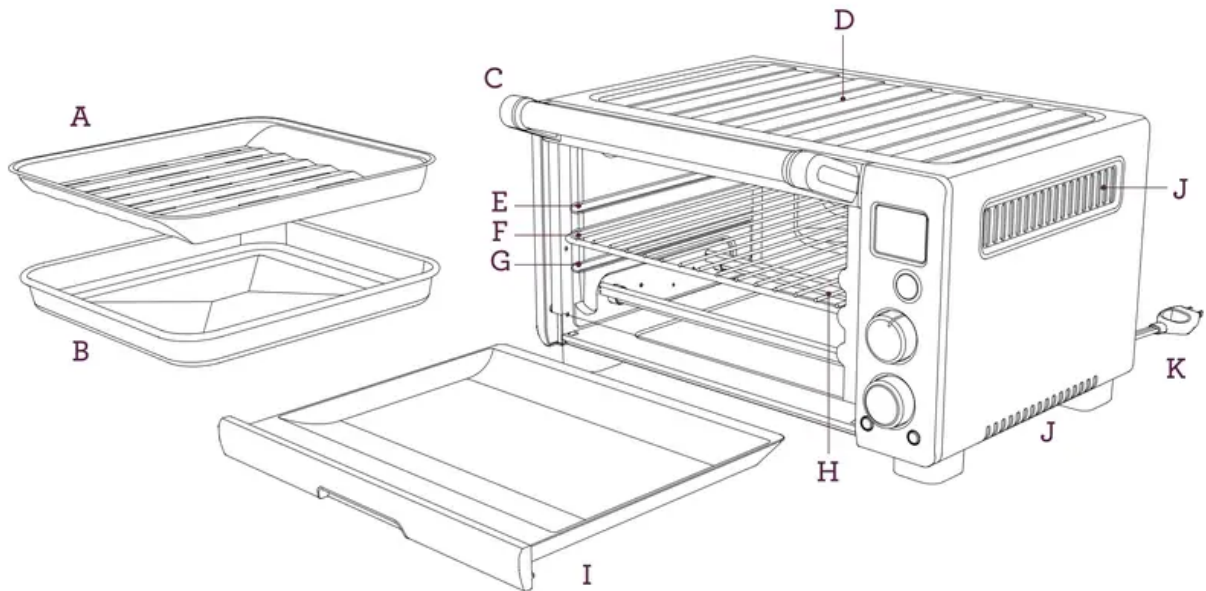

A. **10" x 10" enamel broil rack**

B. **10" x 10" enamel baking pan**

C. **Door handle**

D. **Ribbed plate warming tray**

E. **Top rack height position:**
BROIL and BAGEL function.

F. **Middle rack height position:**
TOAST, PIZZA and COOKIE functions.

G. **Bottom rack height position:**
BAKE, ROAST, and REHEAT functions.

H. **Wire rack**

I. **Crumb tray**

J. **Ventilation slots**

K. **Breville Assist Plug™**

L. **LCD screen**

M. **START/CANCEL button**

N. **Function dial**

O. **TEMPERATURE and TIME dial**

P.  **Temperature conversion button**

Q.  **Frozen foods button**

IMPORTANT: The outer surface of the oven, including the oven door, is hot during and after operation. Always use protective hot pads or insulated oven mitts when inserting, removing or handling items from the oven.

NOTE: Only place items in the ribbed section on top of the oven as described on Page 44.



L

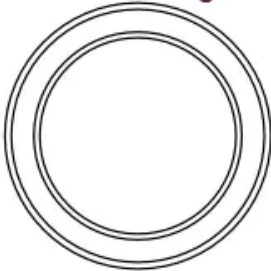

M

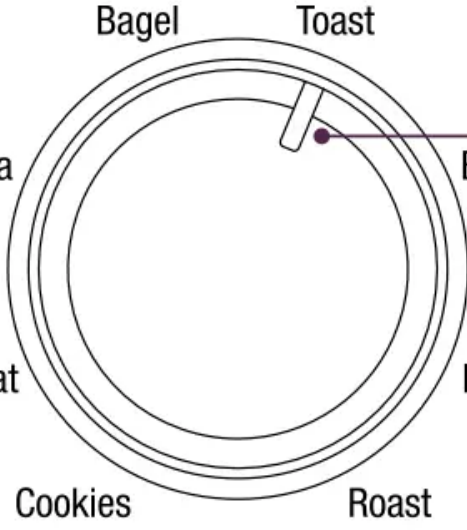

N



O

Q

P



IMPORTANT: Do not touch hot surfaces. The outer surface of the oven, including the oven door, is hot during and after operation. Allow the oven to cool down before handling.

NOTE: When the oven is plugged into a power outlet, the oven alert will sound twice and the LCD screen will illuminate blue for 10 minutes before entering STANDBY mode.

Available accessories sold separately:

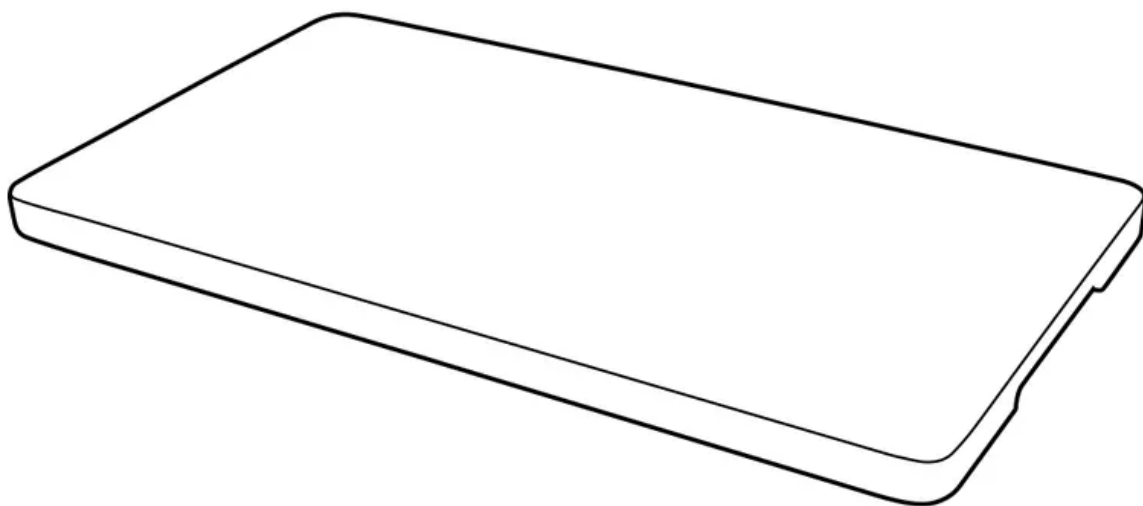

Bamboo Cutting Board

Part No: BOV650CB

Bamboo is the ideal material for a cutting board, as it absorbs very little moisture and has natural antibacterial properties. Bamboo is harder than most hardwoods, leaving less visible knife marks on the board surface.

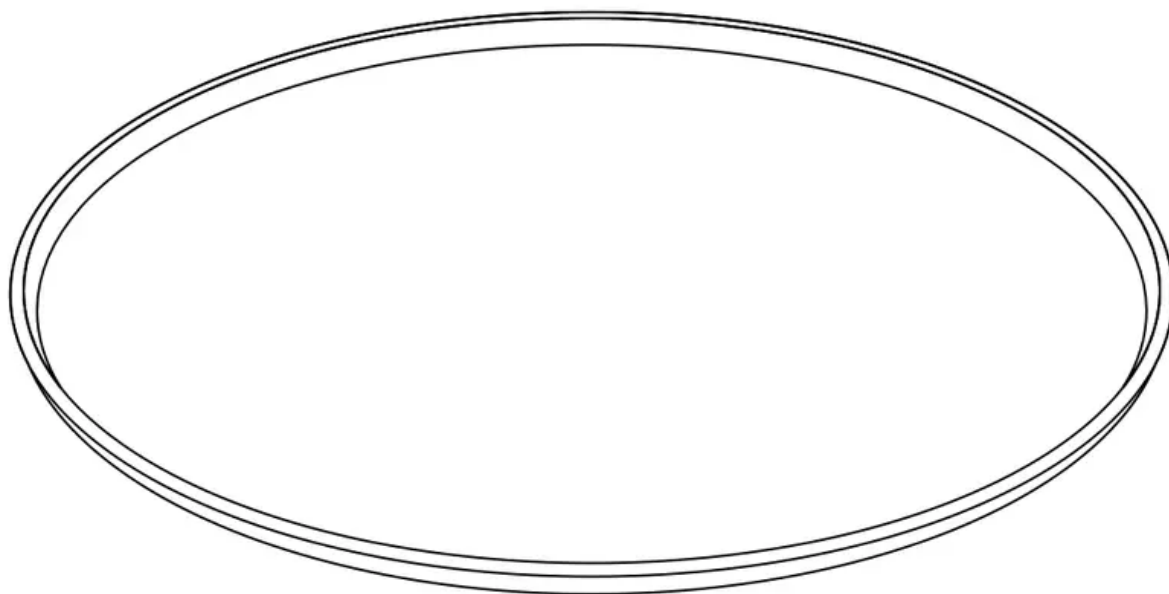

12" Non-stick Pizza Pan

Part No: BOV650PP12

The non-stick coating is for easy release and minimised abrasions while the dark colour absorbs heat and helps to effectively crisp the pizza crust.

Quick Start Guide

This Quick Start Guide is designed for first time use.

For safety and more information, refer to rest of the Instruction Booklet.

PREPARING THE OVEN (A ONE-TIME PROCESS)

In order to remove any protective substances on the heating elements, it is necessary to run the oven empty for 15 minutes. Ensure the area is well ventilated as the oven may emit vapors. These are safe and not detrimental to the performance of the oven.

1. Place the oven on a flat, dry surface. Ensure there is 4" (10cm) of clear space on both sides of the appliance, there are no items on top, and the crumb tray has been inserted.
2. Unwind the power cord and insert the power plug into a power outlet.
3. The oven alert will sound and the LCD screen will illuminate.
4. Turn the FUNCTION dial until the indicator reaches the PIZZA function. The figure on the LCD screen indicates the preset temperature of '425°F'. The preset FROZEN FOODS setting will also be displayed.

FUNCTION DIAL

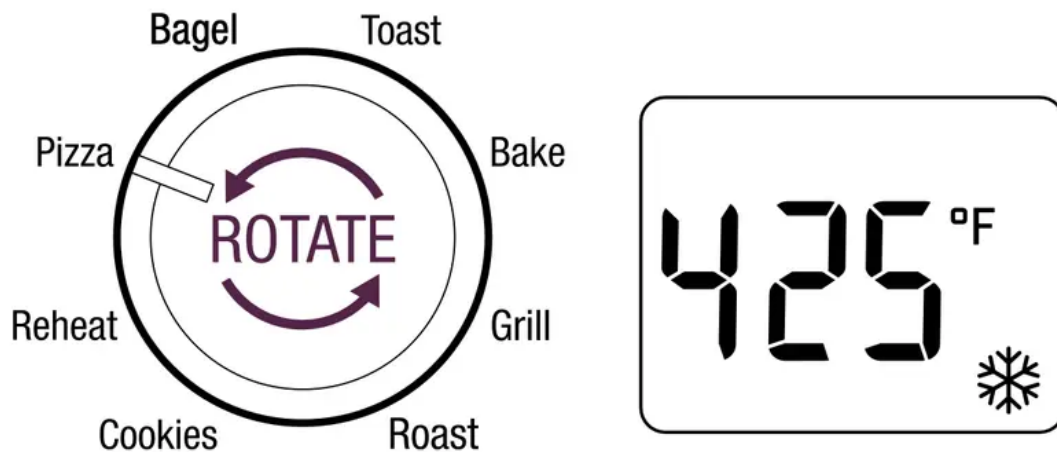

5. Press the START/CANCEL button to activate. The button surround will illuminate red, the oven alert will sound and the LCD screen will illuminate orange.
6. The LCD screen will indicate a blinking 'PREHEATING'. Once the oven has reached the set temperature, the temperature alert will sound.
7. The timer will be displayed and automatically begin to count down in one minute increments.

8. At the end of the cooking cycle, the oven alert will sound three times.

The START/CANCEL button surround will no longer illuminate red and LCD screen will illuminate blue.

9. The oven is now ready to use.

NOTE: When the oven is turned on for the first time, it may emit vapors. This is due to the protective substances on the heating elements. These are safe and not detrimental to the performance of the oven.

OPERATING YOUR BREVILLE COMPACT SMART OVEN™

The Breville Compact Smart Oven™ features Element IQ™ - a cooking technology that adjusts the power of the heating elements to cook food more evenly and quickly. Each of the oven's functions are preset with our recommended settings, however we suggest experimenting with these depending on the recipe, amount of food and your personal taste. Your customized setting will remain in the memory of the oven until changed or the oven is unplugged from the power outlet.

1. Insert the wire rack into the recommended rack height position. These are conveniently printed on the right hand side of the oven door's glass window. The wire rack should be positioned with the spokes facing upwards.

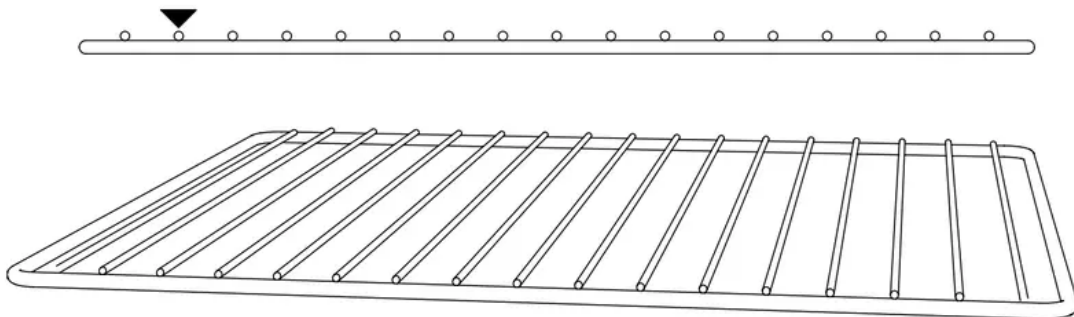

2. Turn the FUNCTION dial until the indicator reaches the desired setting.
3. To change the cooking temperature or time, press the center of the TEMP/TIME dial until the LCD screen displays the corresponding temperature or time screen. Turn the dial to the left to reduce the temperature/time or to the right to increase the temperature/time.

ROTATE

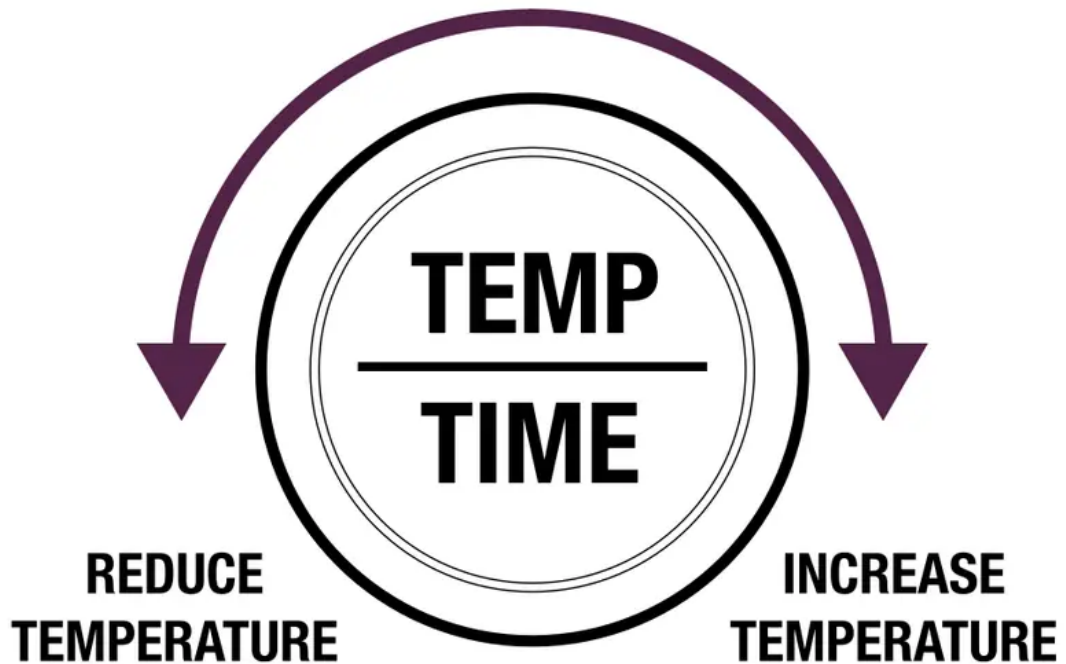

NOTE: The TEMP/TIME dial also functions as the Darkness and Slice selection control on the TOAST and BAGEL functions. Center the food on the wire rack - either placing directly on the rack or positioned on the Breville baking pan and broil rack (see Page 27 of the Instruction Book for recommended cookware types and sizes).

NOTE: Some functions feature a preheating cycle. When the START/CANCEL button is pressed, the LCD screen will indicate a blinking 'PREHEATING'. Only place food inside the oven once the LCD screen no longer blinks 'PREHEATING' and the temperature alert has sounded.

4. Close the oven door.
5. Press the START/CANCEL button to activate. The button surround will illuminate red, the oven alert will sound and the LCD screen will illuminate orange.
6. The timer will be displayed and begin to count down. The cooking temperature and time can be adjusted during the cooking cycle.
7. At the end of the cooking cycle, the oven alert will sound three times. The START/CANCEL button surround will no longer illuminate red and LCD screen will illuminate blue

NOTE: The cooking cycle can be stopped at any time by pressing the START/CANCEL button. This will cancel the cycle and the button surround illumination will go out.

OVEN FUNCTIONS

TOAST FUNCTION: Evenly toasts bread so it's crisp and crunchy on the outside, while soft and moist on the inside.

Rack Position: Middle

Optional Settings:  FROZEN FOODS button.

NOTE: During the toasting cycle, condensation may form on the oven door and steam may be emitted. This is normal - caused by the moisture content of the bread. Freshly baked and frozen breads generally produce more condensation and steam.

BAGEL FUNCTION: Crisps the insides of your cut bagel while only lightly toasting the outside.

Rack Position: Middle

Optional Settings:  FROZEN FOODS button.

NOTE: The upside of the bagel must always face upwards towards the top heating elements - so the top side becomes crisp while the crust is only lightly toasted.

BAKE FUNCTION: Bakes cakes, muffins, brownies and pastries evenly throughout. Also is ideal for cooking pre-packaged frozen meals including lasagna and pies.

Rack Position: Bottom

Optional Settings:  TEMPERATURE CONVERSION button  FROZEN FOODS button.

ROAST FUNCTION: Cooks a variety of meats and poultry that are tender and juicy inside and roasted to perfection outside.

Rack Position: Bottom

Optional Settings:  TEMPERATURE CONVERSION button.

BROIL FUNCTION: Ideal for open sandwiches, small cuts of meat, poultry, fish, sausages and vegetables. Broiling can also be used to brown the tops of casseroles and gratins.

Rack Position: Top

Optional Settings:  TEMPERATURE CONVERSION button.

NOTE: There are two Broiling temperature settings: 'HI' and 'LOW'. This determines how quickly the tops of your food brown - depending on the food, quantity and your personal taste.

NOTE: When Broiling, the Breville Broil rack must be inserted into the Breville baking pan. When assembled together, the Broil rack is designed to drain grease and fats away from meats for

healthier cooking. The baking pan collects these pan drippings and helps prevent spattering. Depending on the food being Broiled, it may be necessary to turn food over half way through the cooking time to achieve even cooking and browning.

PIZZA FUNCTION: Melts and browns cheese and toppings, while crisping the pizza crust.

Rack Position: Middle

Optional Settings:  TEMPERATURE CONVERSION button  FROZEN FOODS button.

NOTE: If cooking a frozen pizza, ensure to remove all packaging (including the metal foil pizza pan that may be provided) before placing the pizza in the oven. If cooking a fresh pizza or using a pizza stone, see Page 37 of the Instruction Book.

COOKIE FUNCTION: Ideal for baking homemade or commercially prepared cookies and ready-to-bake croissants, scones, biscuits and mini tarts or pies.

Rack Position: Middle

Optional Settings:  TEMPERATURE CONVERSION button  FROZEN FOODS button.

REHEAT FUNCTION: Ideal for reheating leftovers without browning the top.

Rack Position: Bottom

Optional Settings:  TEMPERATURE CONVERSION button.

BEFORE FIRST USE

PREPARING THE OVEN FOR USE

1. Remove and safely discard any packing material, promotional labels and tape from the oven.
2. Remove the crumb tray, wire rack, broil rack, and baking pan from the polyfoam packaging. Wash them in warm soapy water with a soft sponge, rinse and dry thoroughly. Insert the crumb tray into the oven.
3. Wipe the interior of the oven with a soft damp sponge. Dry thoroughly.
4. Place the oven on a flat, dry surface. Ensure there is a minimum distance of 4" (10cm) of space on both sides of the appliance. Ensure there are no items on top of the oven.
5. Unwind the power cord completely and insert the power plug into a grounded power outlet.
6. The oven alert will sound twice and the LCD screen will illuminate.

NOTE: In order to remove any protective substances on the heating elements, it is

necessary to run the oven empty for 15 minutes.

NOTE: Ensure the area is well ventilated as the oven may emit vapors. These are safe and not detrimental to the performance of the oven.

7. Turn the FUNCTION dial until the indicator reaches the PIZZA function. The figure on the

LCD screen indicates the preset temperature of '425°F'. The preset  FROZEN FOODS setting will also be displayed.

FUNCTION DIAL

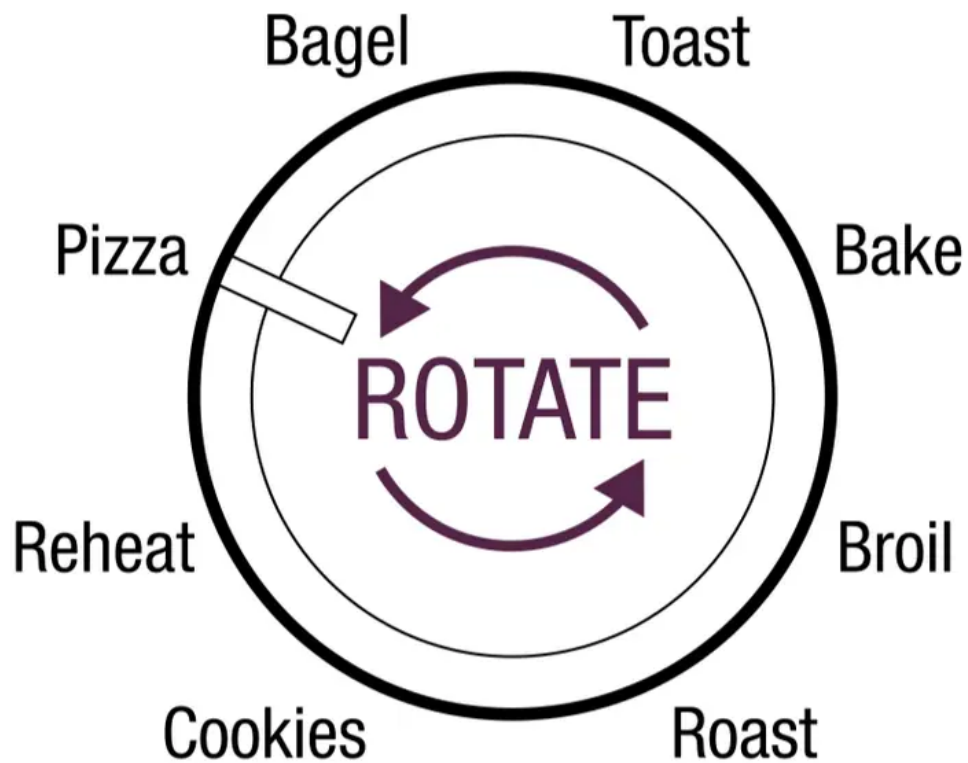

Press the center of the TEMP/TIME dial. The LCD screen will indicate the preset time of '15 MINS'.

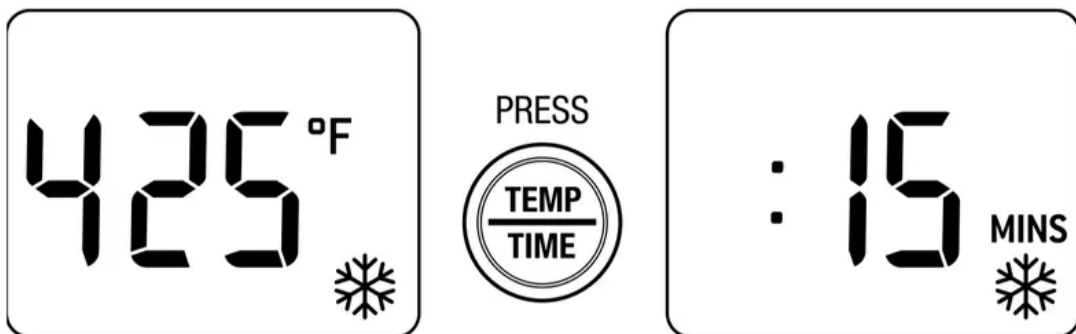

8. Press the START/CANCEL button to activate this setting. The oven alert will sound, the button surround will illuminate red and the LCD screen will illuminate orange.

- The LCD screen will indicate a blinking 'PREHEATING'. Once the oven has reached the set temperature, the temperature alert will sound.
- The time will be displayed and automatically begin to count down in one minute increments.

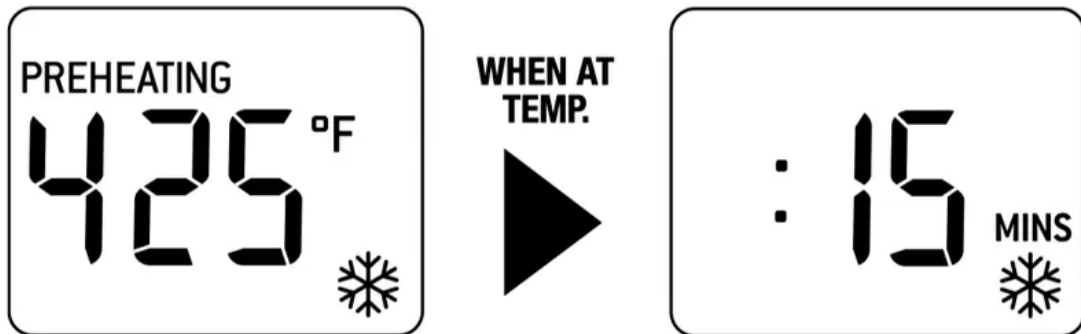

- At the end of the cooking cycle, the oven alert will sound three times. The START/CANCEL button surround will no longer illuminate red and LCD screen will illuminate blue.
- The oven is now ready to use.

NOTE:

- The cooking cycle can be stopped at any time by pressing the START/CANCEL button.
- The START/CANCEL button surround will no longer illuminate red and the LCD screen will illuminate blue.

A NOTE ON COOKING TIMES

The Breville Compact Smart Oven™ features Element IQ™ - a unique cooking technology that adjusts the power of the cooking elements for optimum results.

Broil

High temperature top heat, and low temperature bottom heat: melts and browns.

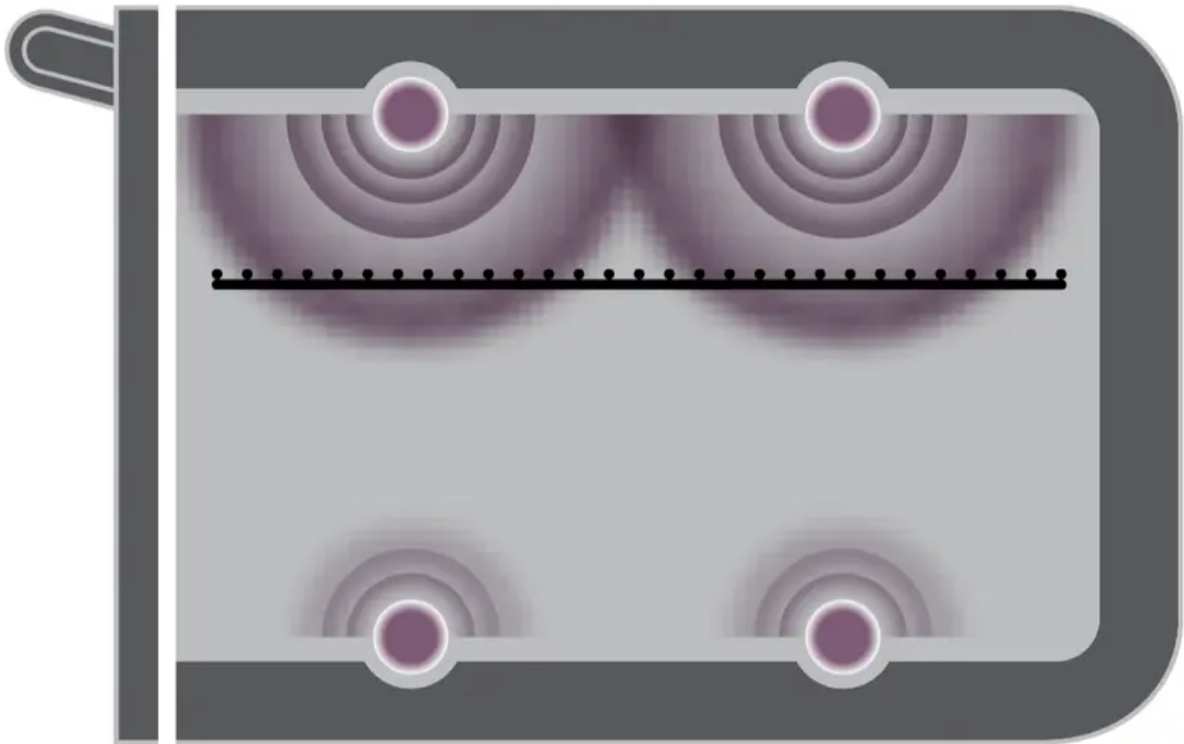

Toast

Searing top and bottom heat: seals and crisps.

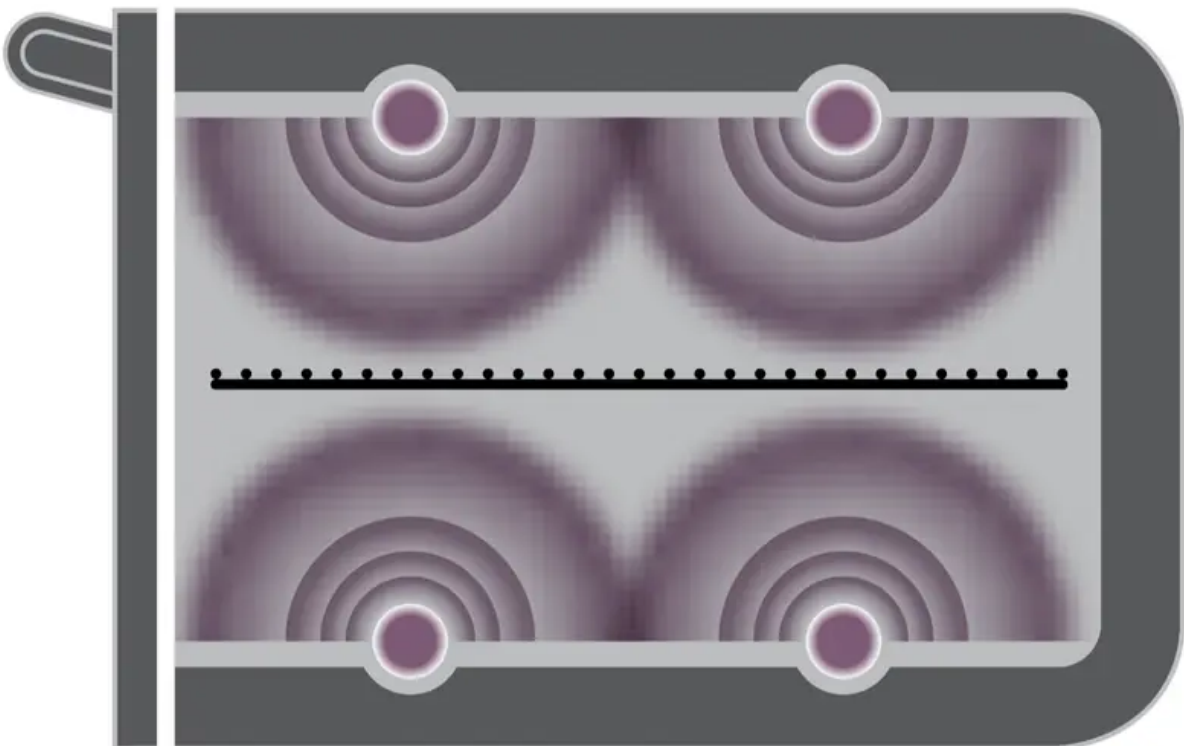

Bake

Even heating: cooks right through.

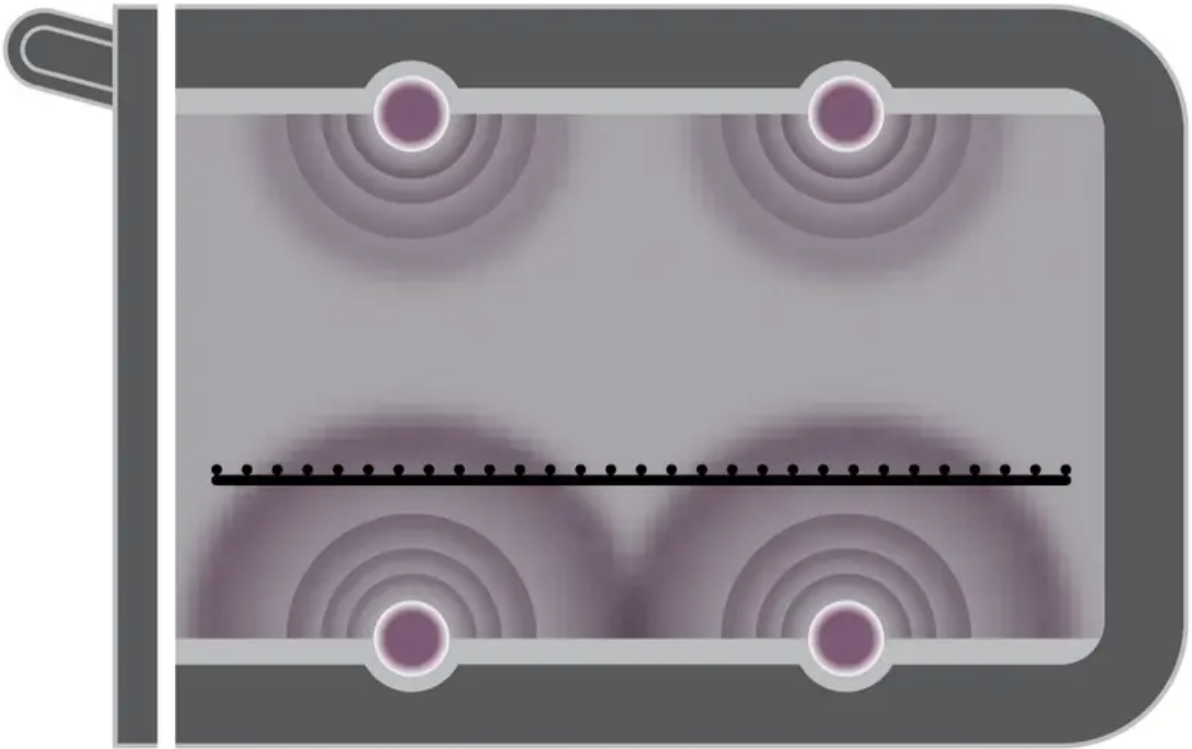

It is normal to notice the following occur during the cooking cycle:

- It is normal that during the broil function, the bottom set of elements turn off while the top set is heating at full power.
- It is normal that the ends of each heating element will glow more brightly than the middle of the element.
- It is normal that the elements are heating even if they are not lighting up.

This cooking technology allows foods to cook more evenly and quickly, significantly reducing cooking times. The oven's preset cooking temperatures and times, as well as the cooking temperature and time directions on pre-packaged foods, may need to be changed depending on the recipe, the amount of food and your personal taste.

We recommend experimenting with the temperature and time settings to produce the desired results.

The cooking temperature and time can be adjusted before or during the cooking cycle.

Pressing the center of the TEMP/TIME dial changes the display on the LCD screen from TEMPERATURE to TIME and vice versa; while rotating the dial increases or decreases the TEMPERATURE or TIME.

NOTE: The TEMP/TIME dial also functions as the Darkness and Slice selection control on the TOAST and BAGEL functions.

a) To change the cooking temperature, press the center of the TEMP/TIME dial until the LCD screen displays the temperature screen.

- Turn the dial to the left to reduce the temperature, or to the right to increase the temperature.

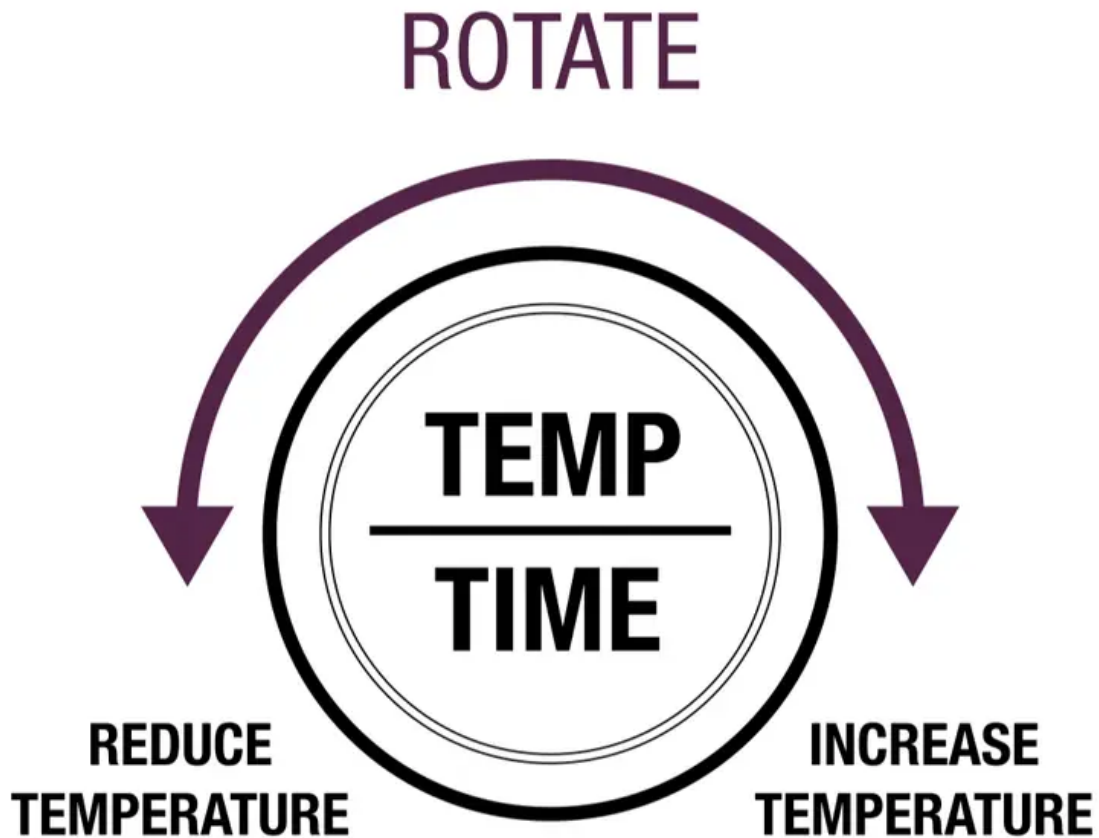

- The cooking temperature can be adjusted in 10°F increments, from 120°F to a maximum of 450°F (or in the Celsius mode, 5°C increments, from 50°C to a maximum 230°C).

b) To change the cooking time, press the center of the TEMP/TIME dial until the LCD screen displays the time screen.

- Turn the dial to the left to reduce the cooking time, or to the right to increase the cooking time.

ROTATE

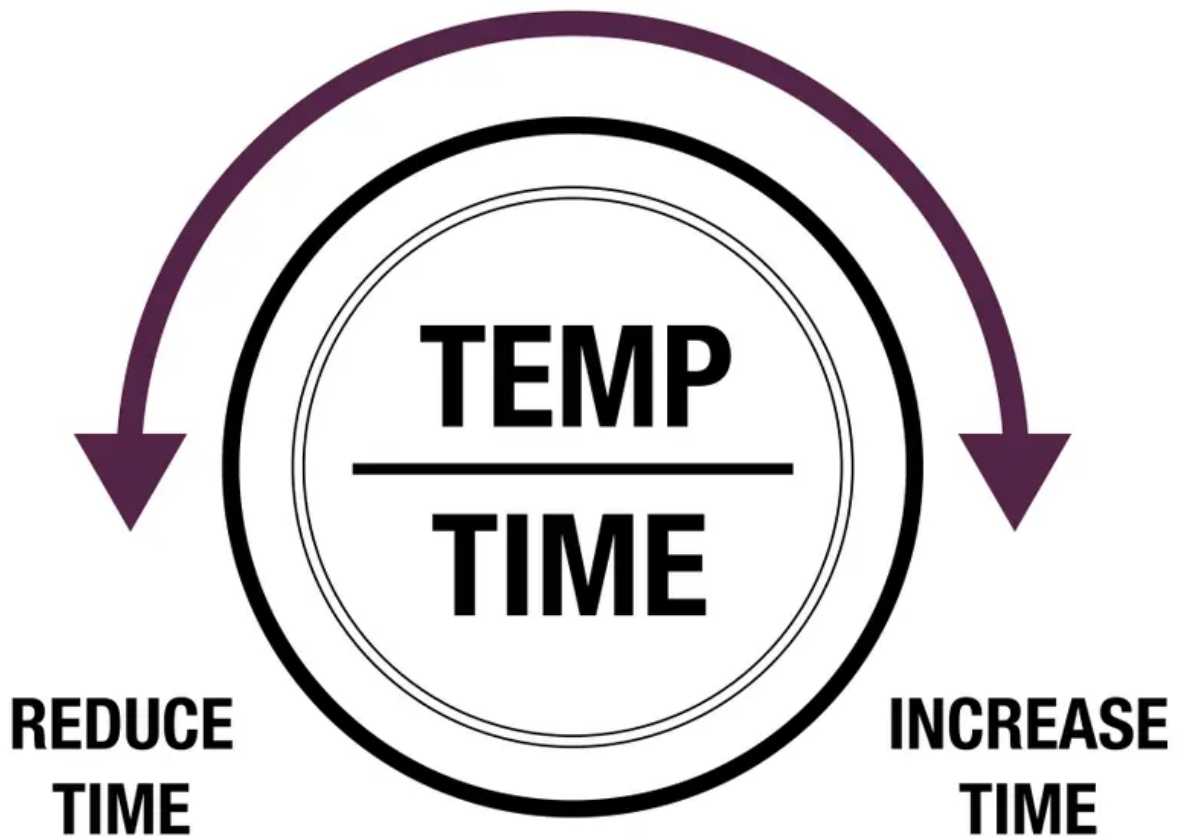

- The cooking time can be adjusted in one minute increments up to 1 hour, and in 5 minute increments between 1 and 2 hours.

A NOTE ON RACK HEIGHT POSITIONS

Cooking results are significantly affected by the position of the wire rack as this determines how close the food is to the heating elements. We highly recommend following the rack height position for each function as printed on the right hand side of the oven door's glass window. However, these are a guide only. Certain foods may require a different rack height position depending on the recipe, the amount and size of the food and your personal taste.

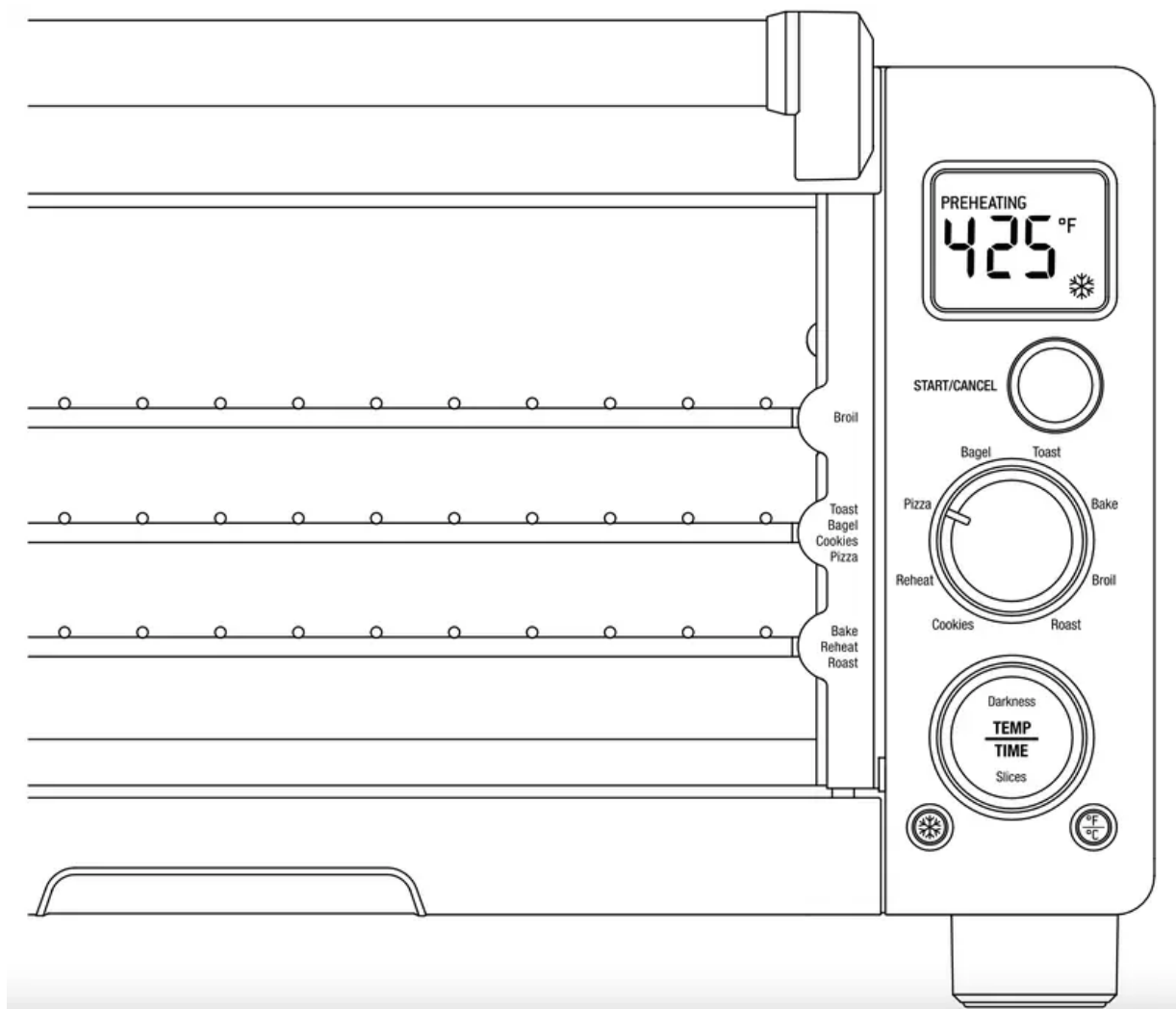

Top rack height position: BROIL and BAGEL functions.

Middle rack height position: TOAST, PIZZA and COOKIE functions.

Bottom rack height position: BAKE, ROAST, and REHEAT functions.

NOTE: When using metal foil to cover accessories, pans, and dishes, it is recommended that the wire rack be in the middle or bottom rack height position. This is to minimize the risk of the metal foil coming into contact with the top heating elements.

For optimum cooking results:

- The wire rack should always be inserted into the rack height position with the spokes facing upwards.

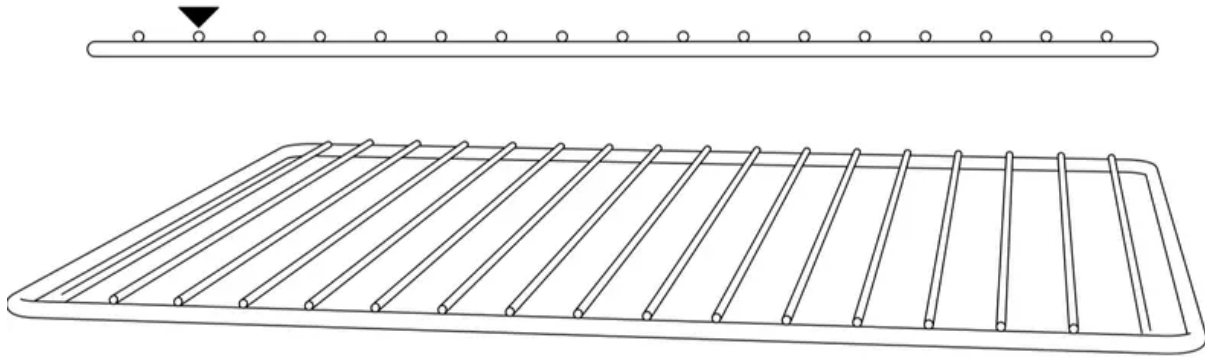

- Food should be positioned on the center of the wire rack, Broil rack or baking tray to let maximum airflow reach the food.

A NOTE ON STANDBY MODE

When the oven is plugged into a power outlet, the oven alert will sound twice and the LCD screen will illuminate for 10 minutes before entering STANDBY mode. When in STANDBY mode, the LCD screen will cease to illuminate, however the word 'STANDBY' will be visible.

To re-activate the oven out of STANDBY mode, press the START/CANCEL button on the control panel, or turn any dial. The LCD screen will re-illuminate. Press the START/CANCEL button to activate the oven.

The oven is ON (preheating and cooking) when the oven alert sounds, the button surround is illuminated red and the LCD screen illuminates orange. The oven is OFF when the START/CANCEL button is pressed a second time, the button surround no longer illuminates red, and the LCD screen illuminates blue.

A NOTE ON OPTIONAL SETTINGS



Temperature Conversion Button

The temperature reading on the oven is preset to Fahrenheit. Pressing the  TEMPERATURE CONVERSION button allows the Fahrenheit temperature reading to be converted to Celsius. The corresponding 'F°' or 'C°' symbol is displayed on the LCD screen.



The  TEMPERATURE CONVERSION button may be selected when using the BAKE, ROAST, BROIL, PIZZA, COOKIE and REHEAT functions.



FAHRENHEIT



CELSIUS

NOTE: The  TEMPERATURE CONVERSION button can be used as an electronic temperature conversion tool, particularly convenient for international recipes.



NOTE: If you have changed the default Celsius temperature reading to Fahrenheit, the setting will remain in the memory of the oven until the  TEMPERATURE CONVERSION button is pressed a second time or the oven is unplugged from the power outlet. When the oven is plugged back into the power outlet, the temperature reading will automatically return to the preset Celsius setting.



Frozen Foods Button

The  FROZEN FOODS button adds the recommended, additional time required to defrost and then toast frozen bread or bagels and cook frozen pizza or cookie dough.

The  FROZEN FOODS button may be selected when using the TOAST, BAGEL, BAKE and COOKIE functions, and is the default setting on the PIZZA function.

On the TOAST, BAGEL, BAKE and COOKIE functions, the  FROZEN FOODS button can be selected before or during the cycle. The setting can be de-selected by pressing the 

FROZEN FOODS button a second time. The frozen symbol  is displayed on the LCD screen whenever this setting is selected.

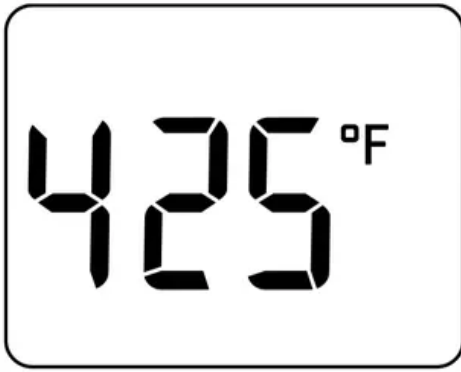





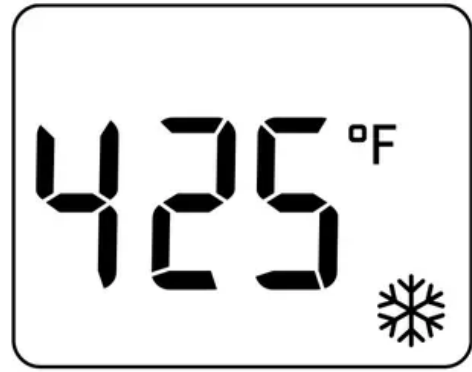

'FROZEN' OFF

**PRESS
FROZEN**



'FROZEN' ON

NOTE: If you have selected the  FROZEN FOODS button and the frozen symbol is displayed on the LCD screen, the setting will remain in the memory of the oven and be activated for each subsequent TOAST / BAGEL / BAKE / COOKIE cycle until the  FROZEN FOODS button is pressed a second time, or the oven is unplugged from the power outlet. When the oven is plugged back into the power outlet, the function will automatically return to the preset TOAST/BAGEL/BAKE/ COOKIE function without the  FROZEN FOODS setting.

On the PIZZA function,  FROZEN FOODS is the default setting, and the frozen symbol  is displayed on the LCD screen. When cooking fresh pizzas, the setting can be de-selected by pressing the  FROZEN FOODS button.

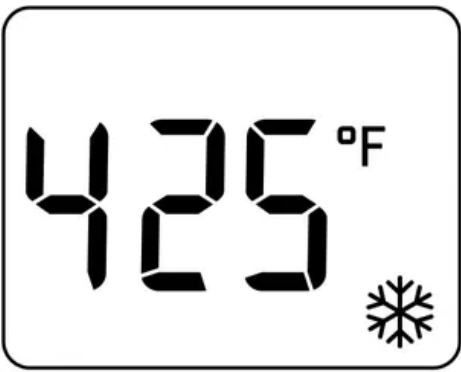

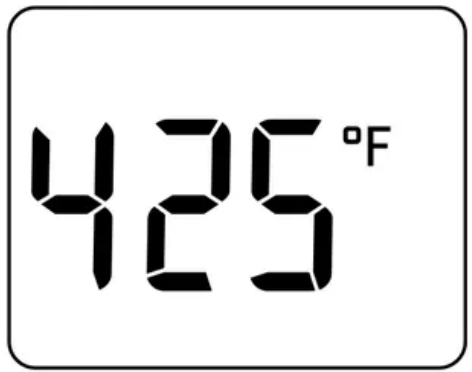

**FROZEN PIZZA
DEFAULT TIME '15 MINS'**

**PRESS
FROZEN**



**FRESH PIZZA
DEFAULT TIME '9 MINS'**

NOTE: If you have de-selected the  FROZEN FOODS setting, the setting will remain in the memory of the oven and be activated for each subsequent PIZZA cycle until the  FROZEN



FOODS button is pressed a second time, or the oven is unplugged from the power outlet. When the oven is plugged back into the power outlet, the function will automatically return to the preset

PIZZA function with the  FROZEN FOODS setting.

OPERATING

OPERATING YOUR BREVILLE COMPACT SMART OVEN™ – TOAST

TOAST FUNCTION

Elements

Top and bottom heating elements cycle on and off to regulate the correct temperature.

Rack Position

Middle rack height position.

Optional Settings



FROZEN FOODS button.

The TOAST function browns and crisps the outside of your bread while keeping the inside soft and moist. This function is also ideal for English muffins and frozen waffles.

1. Insert the wire rack into the middle rack height position. The wire rack should be positioned with the spokes facing upwards.
2. If toasting 1-2 slices, center the slices on the wire rack. If toasting 3-4 slices, evenly space them with 1-2 slices at the front of the wire rack and 1-2 slices at the back of the

rack.

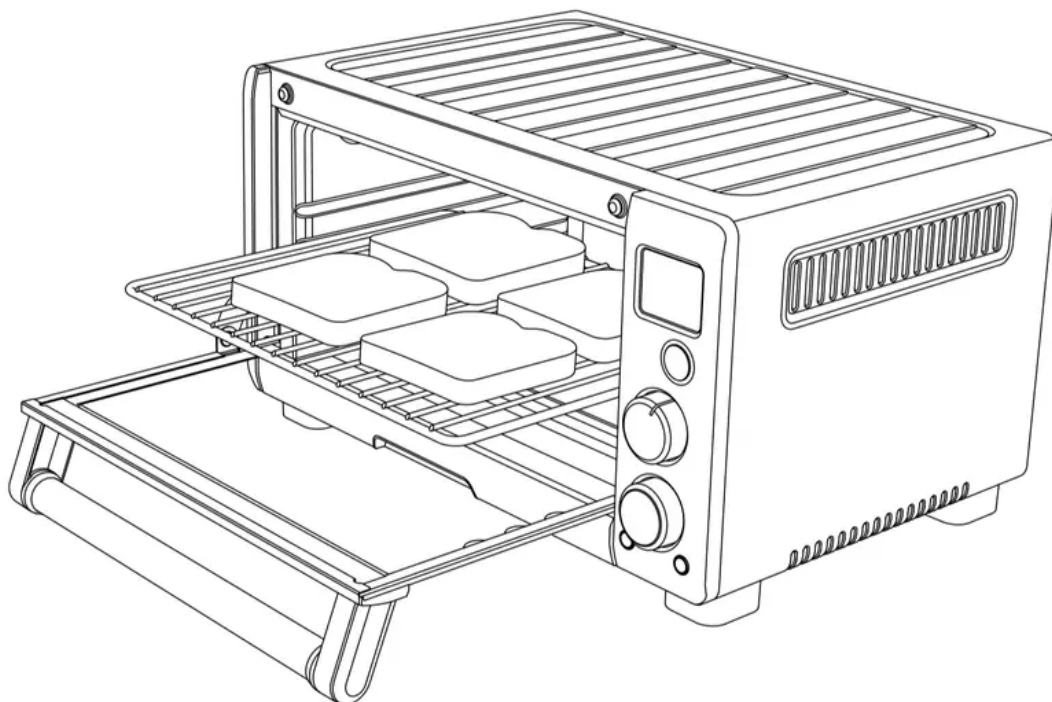

3. Close the oven door.

4. Turn the FUNCTION dial until the indicator reaches the TOAST function. The left figure on the LCD screen indicates the preset browning or 'Darkness' setting '4', while the right figure on the LCD screen indicates the preset number of slices '2'.

FUNCTION DIAL

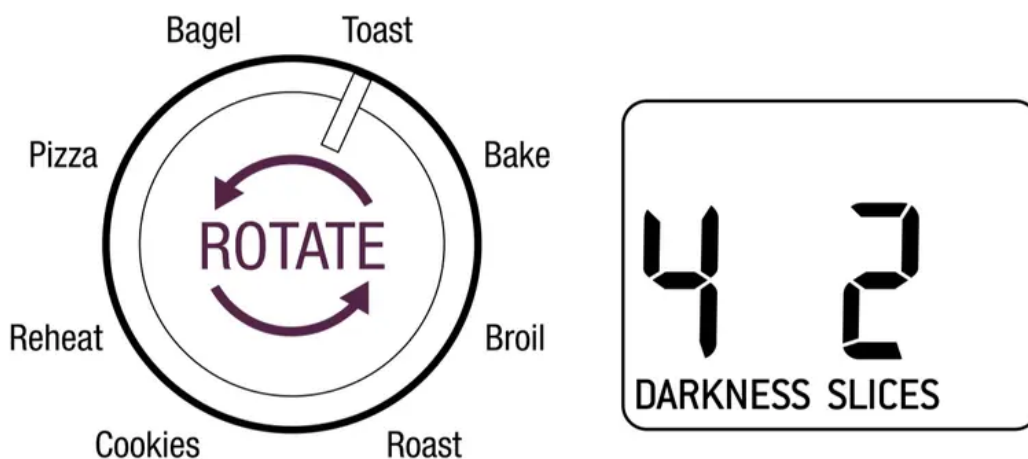

5. The browning setting and number of slices can be adjusted before or during the toasting cycle.

a) To change the browning setting, press the center of the TEMP/TIME (Darkness/Slices) dial until the LCD screen displays a flashing 'DARKNESS'. Turn the dial to the left to reduce the browning setting, or to the right to increase the browning setting. NOTE: The browning settings range from '1' (lightest) to '7' (darkest).

As a general guide:

| DESIRED TOAST COLOR | SETTING |
|---------------------|-----------|
| Light colour toast | 1 or 2 |
| Medium colour toast | 3, 4 or 5 |
| Dark colour toast | 6 or 7 |

When using the TOAST function for the first time, we recommend toasting on the preset browning setting '4' so you can adjust the browning setting to your preference - considering the type, thickness and freshness of the bread.

For example, raisin toast, white light textured breads or thinly sliced bread may require a lighter setting, whilst heavier textured rye, whole wheat or fresh breads may require a darker setting.

b) To change the number of slices, press the center of the TEMP/TIME (Darkness/Slices) dial until the LCD screen displays a flashing 'SLICES'. Turn the dial to the left to reduce the number of slices, or to the right to increase the number of slices. The number of slices range from '1' to '4'.

NOTE: Your customized TOAST browning setting and number of slices will remain in the memory of the oven until you change them or unplug the oven from the power outlet. When the oven is plugged back into the power outlet, the TOAST function will automatically return to the preset browning setting '4' and preset number of slices '2'.

6. Press the START/CANCEL button to activate this setting. The button surround will illuminate red, the oven alert will sound and the LCD screen will illuminate orange.
7. The timer will be displayed and begin to count down. The time can be adjusted during the toasting cycle by turning the TEMP/TIME dial.

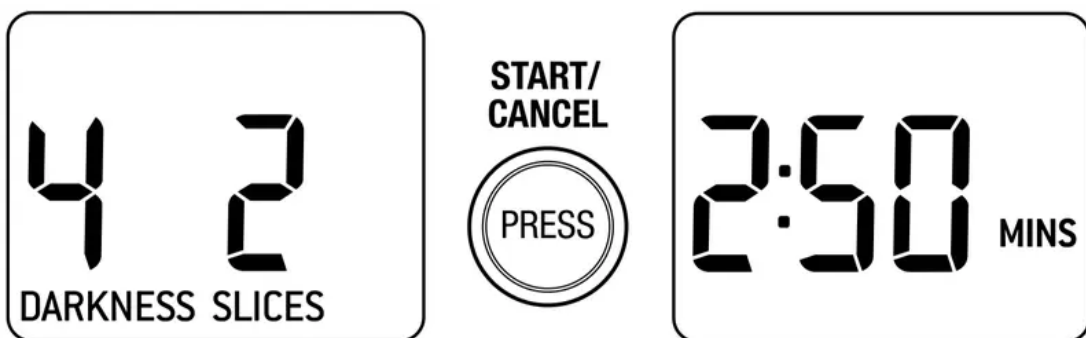

NOTE:

Element IQ™ will automatically adjust the toasting time depending on the heat already present inside the oven. For example, if the oven is already warm after one cycle of toasting, the toasting time for the second cycle will be less.

During the toasting cycle, condensation may form on the oven door and steam may be emitted. This is normal. Condensation and steam occur as a result of the moisture

content of the bread. Freshly baked and frozen breads generally produce more condensation.

8. At the end of the toasting cycle, the oven alert will sound three times. The START/CANCEL button surround will no longer illuminate red and LCD screen will illuminate blue.

IMPORTANT: The outer surface of the oven, including the oven door, is hot during and after operation. Always use protective hot pads or insulated oven mitts when inserting, removing or handling items from the oven.

9. The toasting cycle can be stopped at any time by pressing the START/CANCEL button. This will cancel the cycle. The button surround illumination will go out and the LCD screen will illuminate blue.

NOTE: Default temperatures and times shown in the illustrations in this section may vary from those displayed on your oven.

OPERATING YOUR BREVILLE COMPACT SMART OVEN™ – BAGEL

BAGEL FUNCTION

Elements

Top and bottom heating elements cycle on and off to regulate the correct temperature.

Rack Position

Middle rack height position.

Optional Settings



FROZEN FOODS button.

The BAGEL function crisps the insides of your cut bagel while only lightly toasting the outside. This function is also ideal for toasting thick sliced speciality breads which require one side to be toasted more than the other.

NOTE: If you like your bagel halves equally crisp on both the top and bottom, we recommend using the TOAST function to toast your cut bagel.

1. Insert the wire rack into the top rack height position. The wire rack should be positioned with the spokes facing upwards.
2. Slice each bagel into two equal halves
3. If toasting 1-2 bagel halves, center the halves on the wire rack. If toasting 3-4 halves, evenly space them with 1-2 halves at the front of the wire rack and 1-2 halves at the back of the rack.

NOTE: The upside of the bagel must always face upwards towards the top heating elements. This allows the topside to be crisp while the crust is only lightly toasted.

NOTE: For bagels, change the rack to the middle rack height position, cut the bagel in half, lengthways. The upside(cutside) of the bagel must always face upwards towards the top heating elements - so the topside(cutside) becomes crisp while the crust is only lightly toasted.

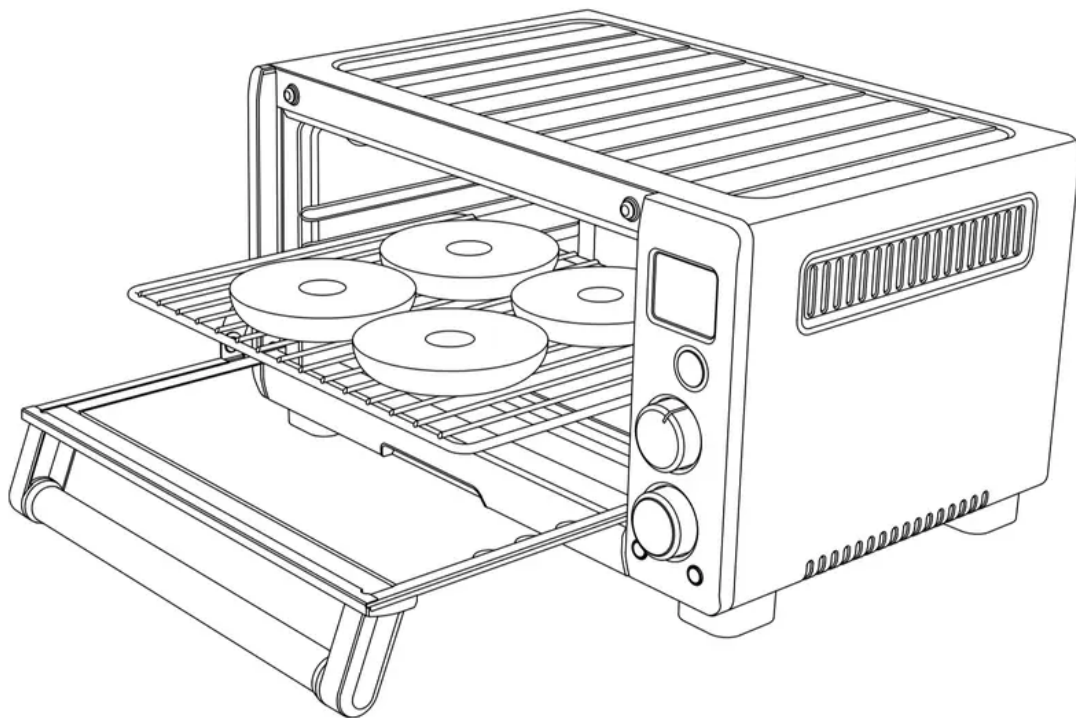

4. Close the oven door.
5. Turn the FUNCTION dial until the indicator reaches the BAGEL function. The left figure on the LCD screen indicates the preset browning or 'Darkness' setting '4', while the right figure on the LCD screen indicates the preset number of bagel halves '2'.

FUNCTION DIAL

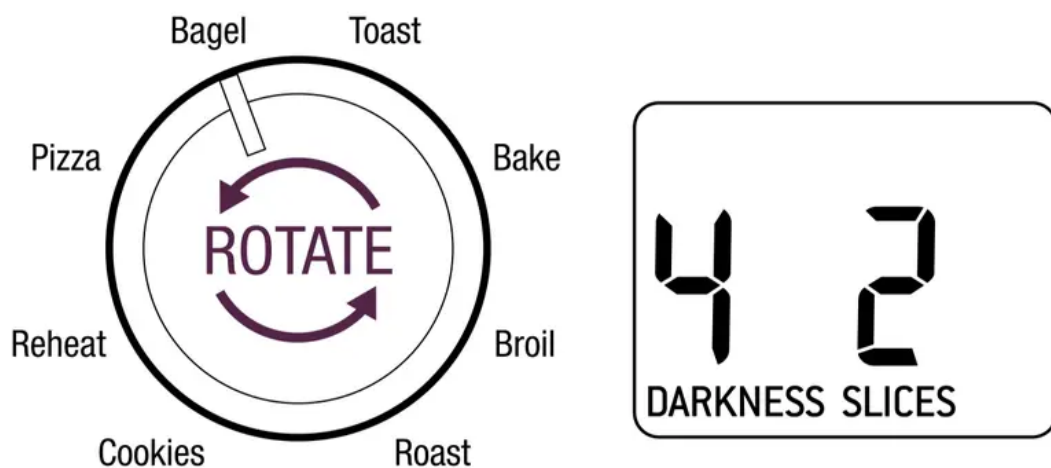

6. The browning setting and number of bagel halves can be adjusted before or during the bagel cycle.
 - a) To change the browning setting, press the center of the TEMP/TIME (Darkness/Slices) dial until the LCD screen displays a flashing 'DARKNESS'. Turn the dial to the left to

reduce the browning setting, or to the right to increase the browning setting.

NOTE: The browning settings range from '1' (lightest) to '7' (darkest).

As a general guide:

| DESIRED BAGEL COLOR | SETTING |
|---------------------|-----------|
| Light color bagel | 1 or 2 |
| Medium color bagel | 3, 4 or 5 |
| Dark color bagel | 6 or 7 |

When using the BAGEL function for the first time, we recommend toasting on the preset browning setting '4' so you can adjust the browning setting to your preference considering the type and freshness of the bagel.

b) To change the number of bagel halves, press the center of the TEMP/TIME (Darkness/Slices) dial until the LCD screen displays a flashing 'SLICES'. Turn the dial to the left to reduce the number of bagel halves, or to the right to increase the number of bagel halves. The number of bagel halves range from '1' to '4'.

NOTE: Your customized BAGEL browning setting and number of bagel halves will remain in the memory of the oven until you change them or unplug the oven from the power outlet. When the oven is plugged back into the power outlet, the BAGEL function will automatically return to the preset browning setting '4' and preset number of bagel halves '2'.

7. Press the START/CANCEL button to activate this setting. The button surround will illuminate red, the oven alert will sound and the LCD screen will illuminate orange.
8. The timer will be displayed and begin to count down. The time can be adjusted during the bagel cycle by turning the TEMP/TIME dial.

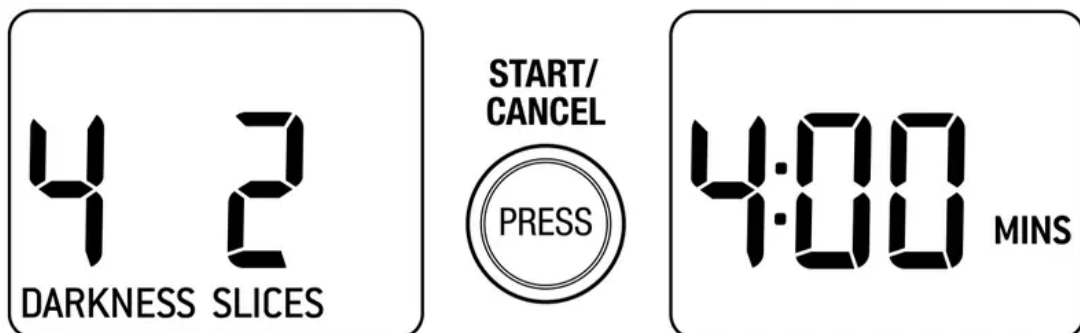

NOTE: During the BAGEL function, Element IQ™ will automatically adjust the power of the cooking elements for optimum results. It is normal to notice the bottom set of elements turn off while the top set is heating at full power. This ensures the inside of the

bagel is crisp while the crust is only lightly toasted.

NOTE: Element IQ™ will automatically adjust the toasting time depending on the heat already present inside the oven. For example, if the oven is already warm after one cycle of toasting, the toasting time for the second cycle will be less.

9. At the end of the cooking cycle, the oven alert will sound three times. The START/CANCEL button surround will no longer illuminate red and LCD screen will illuminate blue.

IMPORTANT: The outer surface of the oven, including the oven door, is hot during and after operation. Always use protective hot pads or insulated oven mitts when inserting, removing or handling items from the oven.

10. The bagel cycle can be stopped at any time by pressing the START/CANCEL button. This will cancel the cycle. The button surround illumination will go out and the LCD screen will illuminate blue.

OPERATING YOUR BREVILLE COMPACT SMART OVEN™ – BAKE

BAKE FUNCTION

Elements Top and bottom heating elements cycle on and off to regulate the correct temperature.

Rack Position

Bottom rack height position.

Optional Settings



FROZEN FOODS button.



TEMPERATURE CONVERSION button.

The BAKE function cooks food evenly throughout. This function is ideal for baking cakes, muffins, brownies and pastries. The BAKE function is also ideal for cooking prepackaged frozen meals including lasagna and pot pies.

1. Insert the wire rack into the bottom rack height position. The wire rack should be positioned with the spokes facing upwards.

NOTE: We recommend using the bottom rack height position during the BAKE function. However this is a guide only. The position of the rack may vary depending on the type and size of food being baked. Some baked goods such as brownies or pastries may be more suited to the middle rack height position.

2. Close the oven door.

- Turn the FUNCTION dial until the indicator reaches the BAKE function. The LCD screen indicates the preset BAKE temperature of '325°F'.

FUNCTION DIAL

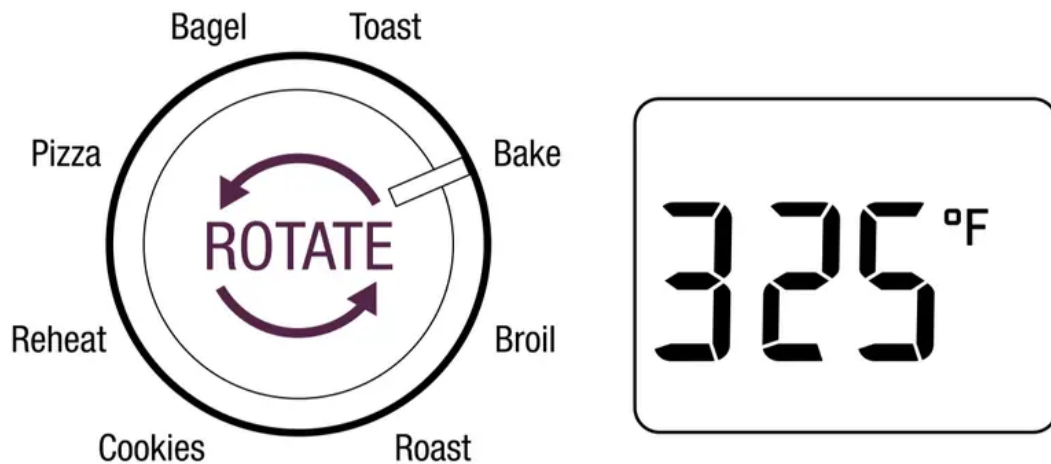

- The baking temperature and time can be adjusted before or during the baking cycle.
 - The preset '325°F' is displayed as default baking temperature on the LCD screen. To select the baking temperature, turn the TEMP/TIME dial to adjust the baking temperature in 10°F increments, from 120°F to a maximum of 450°F (or in the Celsius mode, 5°C increments, from 50°C to a maximum 230°C)
 - To select the baking time, press the center of the TEMP/TIME dial until the LCD screen displays the preset baking time of ':30 MINS'.

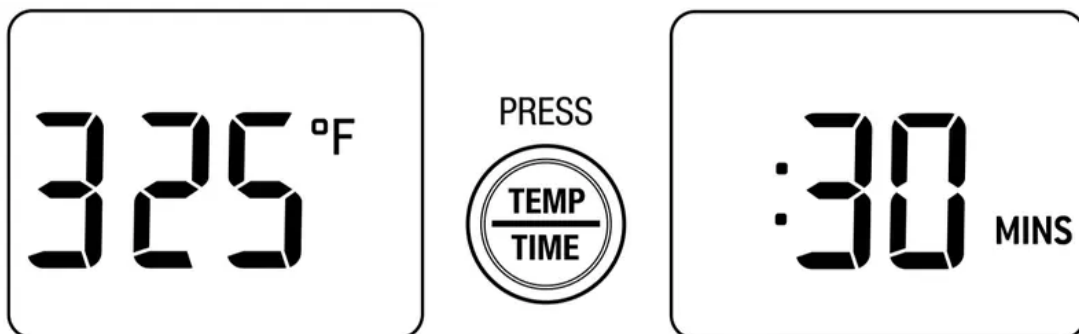

Turn the dial to adjust the baking time in one minute increments up to 1 hour, and in 5 minute increments between 1 and 2 hours.

NOTE: Your customized BAKE temperature and time settings will remain in the memory of the oven until you change them or unplug the oven from the power outlet. When the oven is plugged back into the power outlet, the BAKE function will automatically return to the preset temperature of '325°F' and preset time of ':30 MINS'.

- Press the START/CANCEL button to activate this setting. The button surround will illuminate red, the oven alert will sound and the LCD screen will illuminate orange.

6. The LCD screen will indicate a blinking 'PREHEATING'. Once the oven has reached the set temperature, the temperature alert will sound.

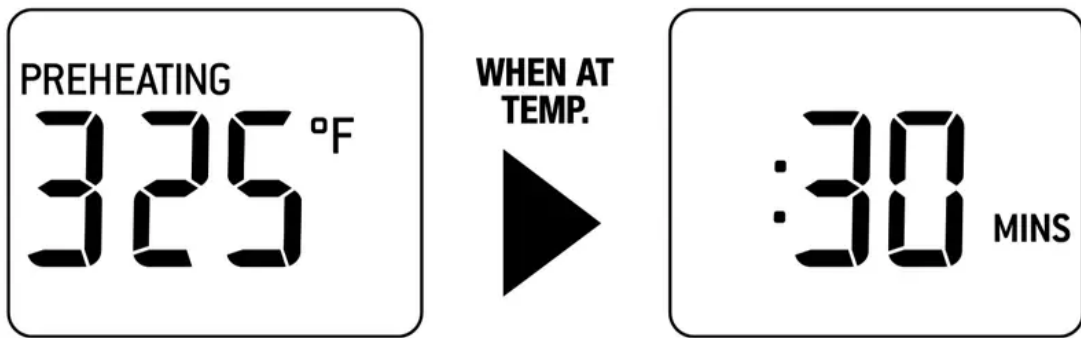

7. Place food, positioned on the Breville enamel baking pan or in an oven-proof dish, on the center of the wire rack so air flows around the sides of the food.

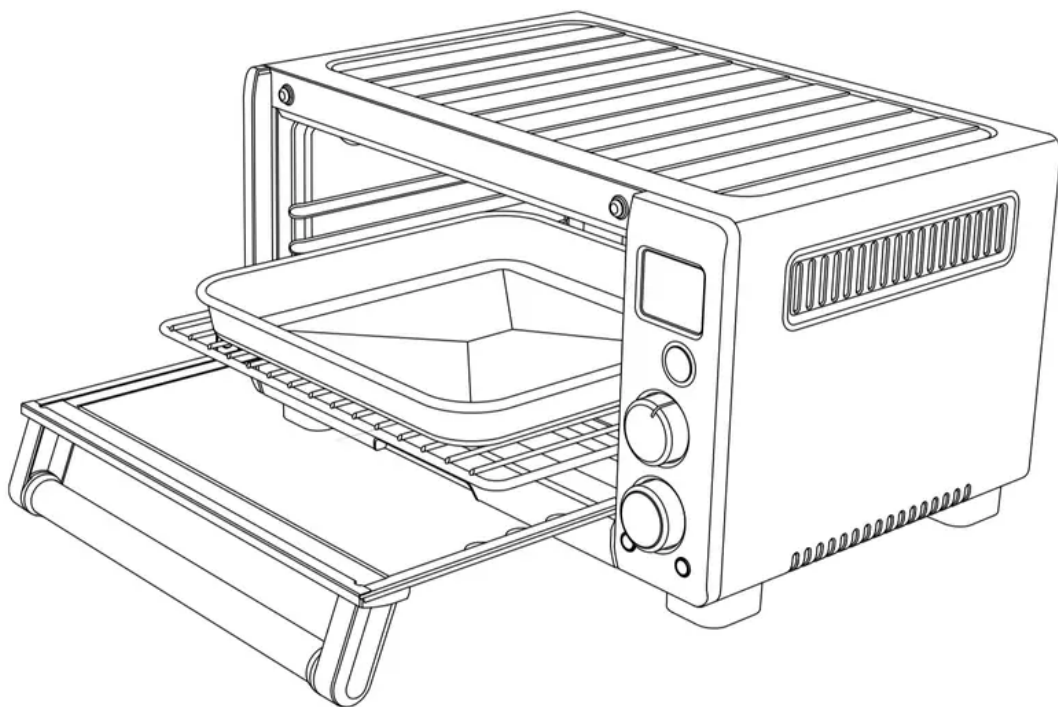

IMPORTANT: The outer surface of the oven, including the oven door, is hot during and after operation. Always use protective hot pads or insulated oven mitts when inserting, removing or handling items from the oven.

NOTE: The following bakeware will fit into the oven:

7 ½" x 11" baking pan no handles

9" square baking pan

6 cup muffin tin

9" loaf pan

Up to 11" pie plate

NOTE: For questions regarding the use of oven safe and specialty bakeware in compact ovens, please contact the bakeware manufacturer directly.

NOTE: Citric acid, found in foods such as orange, lemon and lime juice, may damage the porcelain enamel finish of the baking pan and broiling rack. When cooking foods with

high citric acid content, we strongly recommend lining the enamel surfaces with foil or baking paper to extend the life of these accessories.

NOTE: Caution should be exercised when using metal foil to cover accessories, pans, and dishes. Be sure that the metal foil is fitted securely as close contact with the oven's heating elements can cause overheating and risk of fire.

NOTE: When using metal foil to cover accessories, pans, and dishes, it is recommended that the wire rack be in the middle or bottom rack height position. This is to minimize the risk of the metal foil coming into contact with the top heating elements.

NOTE: Caution should be exercised when using pans and dishes constructed of materials other than metal. If using ceramic or glass pans or dishes it is important that they are oven safe to prevent cracking.

NOTE: Caution should be exercised when using lids in the oven, as pressure build up in a covered pan or dish may cause hot ingredients to expel or the dish to crack.

8. After the PREHEATING alert has sounded, the timer will automatically begin to count down in one minute increments. The temperature and time can be adjusted during the baking cycle by turning the TEMP/TIME dial. Toggle between the temperature and time LCD screen by pressing the center of the TEMP/TIME dial.

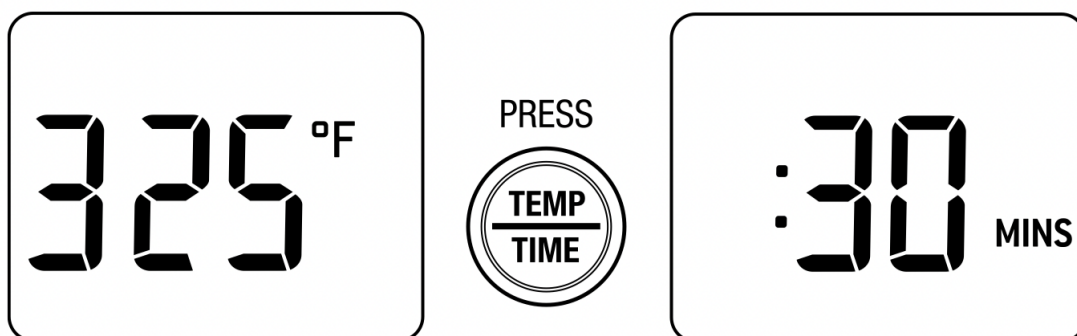

9. At the end of the cooking cycle, the oven alert will sound three times. The START/CANCEL button surround will no longer illuminate red and LCD screen will illuminate blue.
10. The baking cycle can be stopped at any time by pressing the START/CANCEL button. This will cancel the cycle. The button surround illumination will go out and the LCD screen will illuminate blue.

OPERATING YOUR BREVILLE COMPACT SMART OVEN™ – ROAST

Elements

Top and bottom heating elements cycle on and off to regulate the correct temperature.

Rack Position

Bottom rack height position.

Optional Settings



TEMPERATURE CONVERSION button.

The ROAST function is ideal for cooking a variety of meats and poultry that are tender and juicy on the inside and roasted to perfection on the outside.

1. Insert the wire rack into the bottom rack height position. The wire rack should be positioned with the spokes facing upwards.
2. Close the oven door.
3. Turn the FUNCTION dial until the indicator reaches the ROAST function. The LCD screen indicates the preset ROAST temperature of '350°F'.

FUNCTION DIAL

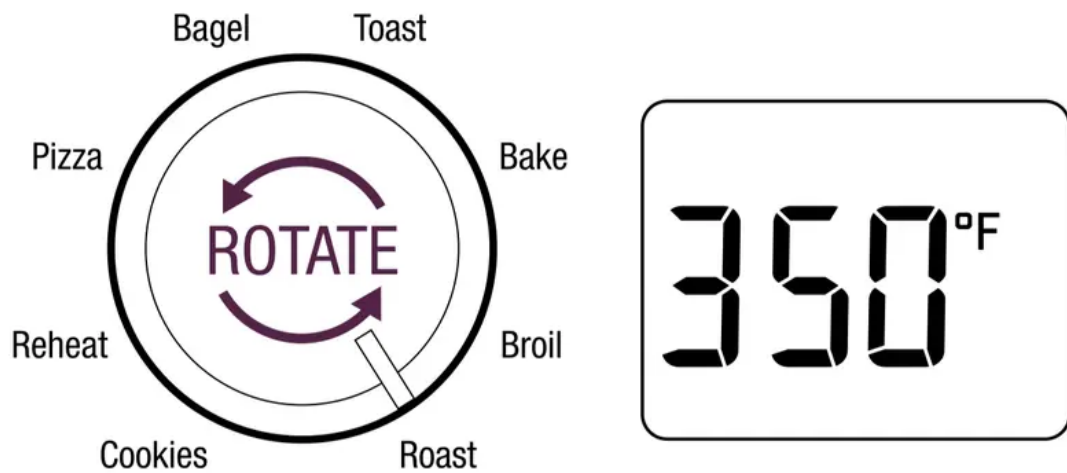

4. The roasting temperature and time can be adjusted before or during the roasting cycle.
 - a) The preset '350°F' is displayed as default roasting temperature on the LCD screen. Turn the TEMP/TIME dial to adjust the roasting temperature in 10°F increments, from 120°F to a maximum of 450°F (or in the Celsius mode, 5°C increments, from 50°C to a maximum 230°C).
 - b) To select the roasting time, press the center of the TEMP/TIME dial until the LCD screen displays the preset roasting time of '1:00 HRS'.

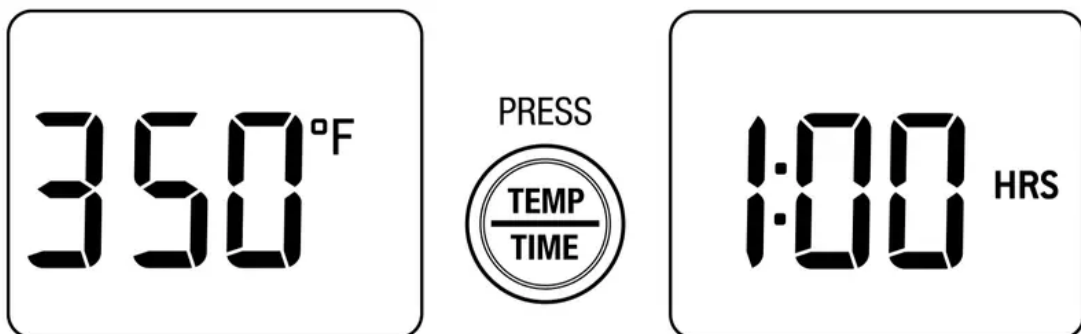

Turn the dial to adjust the roasting time in one minute increments up to 1 hour, and in 5 minute increments between 1 and 2 hours.

NOTE: Use the table below as a guide only to estimate and plan cooking times. We

recommend checking doneness with a reliable meat thermometer.

| TYPE/CUT | ROASTING TIME PER 1LB (500G) |
|------------------------------------|------------------------------|
| Beef - Rib Eye, Round or Rib Roast | 30 minutes |
| Pork - Loin (bone in/out) | 35 minutes |
| Lamb - Leg (bone in/out) | 30 minutes |
| Chicken - Whole | 30 minutes |

NOTE: We recommend limiting the weight of meats and poultry to be roasted to 4.5 lbs (2kg). However the actual maximum weight will vary depending on the type, cut, shape and size of the meat.

NOTE: Your customized ROAST temperature and time settings will remain in the memory of the oven until you change them or unplug the oven from the power outlet. When the oven is plugged back into the power outlet, the ROAST function will automatically return to the preset temperature of '350°F' and preset time of '1:00 HRS'.

5. Press the START/CANCEL button to activate this setting. The button surround will illuminate red, the oven alert will sound, and the LCD screen will illuminate orange.
6. The LCD screen will indicate a blinking 'PREHEATING'. Once the oven has reached the set temperature, the temperature alert will sound.

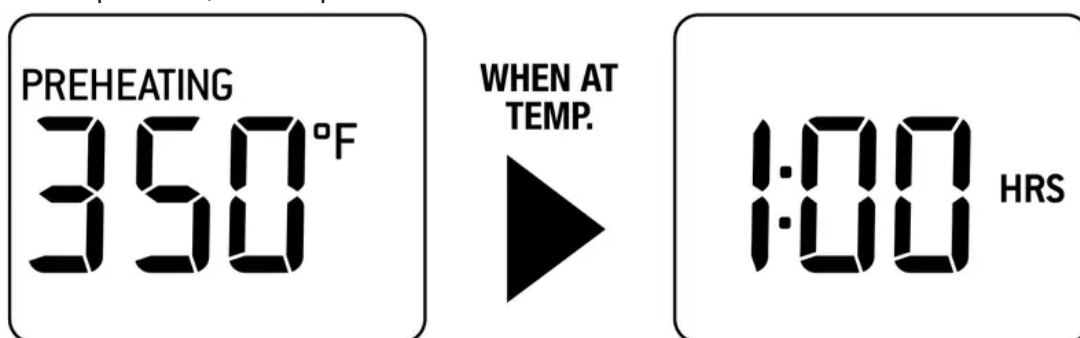

7. Place food, positioned on the Breville enamel baking pan or in an oven-proof dish, on the center of the wire rack so air flows around the sides of the food.

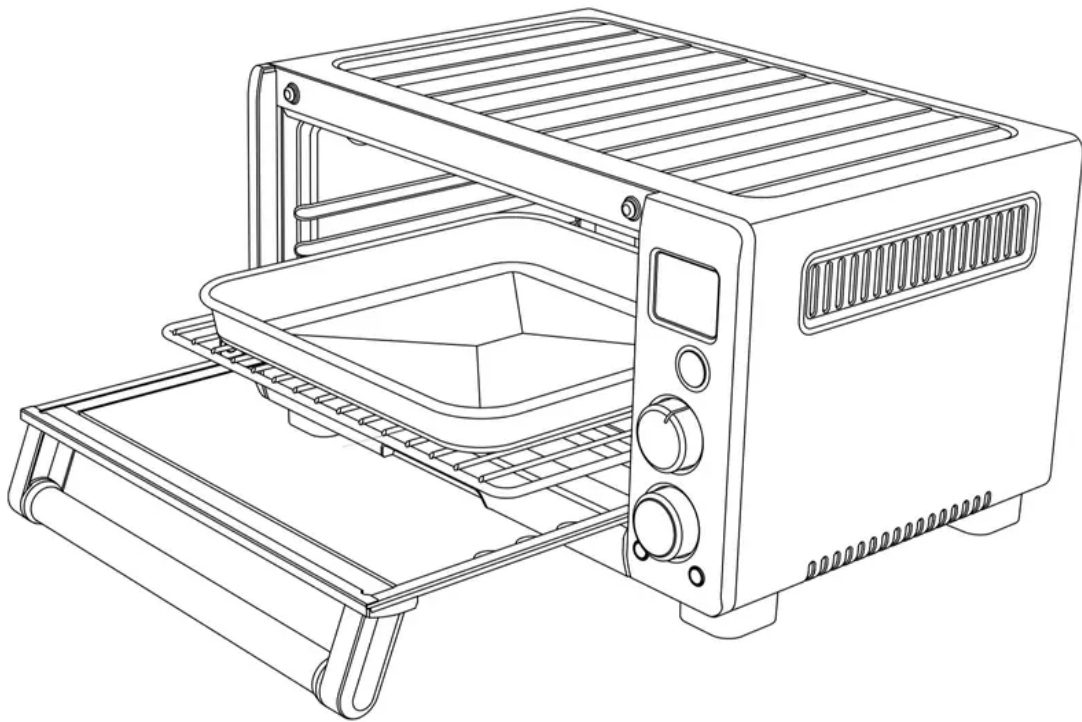

IMPORTANT: The outer surface of the oven, including the oven door, is hot during and after operation. Always use protective hot pads or insulated oven mitts when inserting, removing or handling items from the oven.

NOTE: When roasting, the Breville enamel broil rack may be inserted into Breville enamel baking pan. When assembled together, the broil rack is designed to drain grease and fats away from meats for healthier cooking. The baking pan collects these pan drippings and helps prevent spattering.

NOTE: When using metal foil to cover accessories, pans, and dishes, it is recommended that the wire rack be in the middle or bottom rack height position. This is to minimize the risk of the metal foil coming into contact with the top heating elements.

NOTE: Caution should be exercised when using pans and dishes constructed of materials other than metal. If using ceramic or glass pans or dishes it is important that they are oven safe to prevent cracking.

NOTE: Caution should be exercised when using lids in the oven, as pressure build up in a covered pan or dish may cause hot ingredients to expel or the dish to crack.

8. After the PREHEATING alert has sounded, the timer will automatically begin to count down in one minute increments. The temperature and time can be adjusted during the roasting cycle by turning the TEMP/TIME dial. Toggle between the temperature and time

LCD screen by pressing the center of the TEMP/TIME dial.

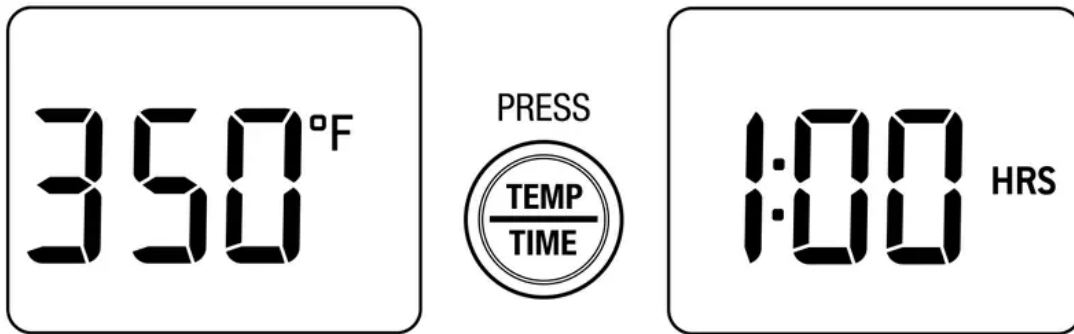

- At the end of the cooking cycle, the oven alert will sound three times. The START/CANCEL button surround will no longer illuminate red and LCD screen will illuminate blue.

NOTE: Check doneness with a reliable meat thermometer. Use an independent timer to remind you to check the meat temperature.

- The roast cycle can be stopped at any time by pressing the START/CANCEL button. This will cancel the cycle. The button surround illumination will go out and the LCD screen will illuminate blue.

OPERATING YOUR BREVILLE COMPACT SMART OVEN™ – BROIL

BROIL FUNCTION

Elements

Top heating elements cycle on and off to provide intense top heat. Bottom heating elements remain on low.

Rack Position

Top rack height position.

Optional Settings



TEMPERATURE CONVERSION button.

The BROIL function is ideal for open sandwiches, small cuts of meat, poultry, fish, sausages and vegetables. Broiling can also be used to brown the tops of casseroles and gratins.

- Insert the wire rack into the top rack height position. The wire rack should be positioned with the spokes facing upwards.

NOTE: We recommend using the top rack height position during the BROIL function. However this is a guide only. Certain foods may require the middle rack height position depending on the recipe, the amount and size of the food and your personal taste. For example, the middle rack height position may be more appropriate for taller foods that may touch the heating elements, thicker foods such as hamburger patties, marinated

foods such as chicken wings, or foods that require a gentle broil. We recommend experimenting with the rack height position, as well as the temperature and time settings to produce the desired results.

2. Insert the Breville enamel broil rack into the enamel baking pan. Place food on the assembled broil rack or in an oven-proof dish, then place on the center of the wire rack so air flows around the sides of the food.

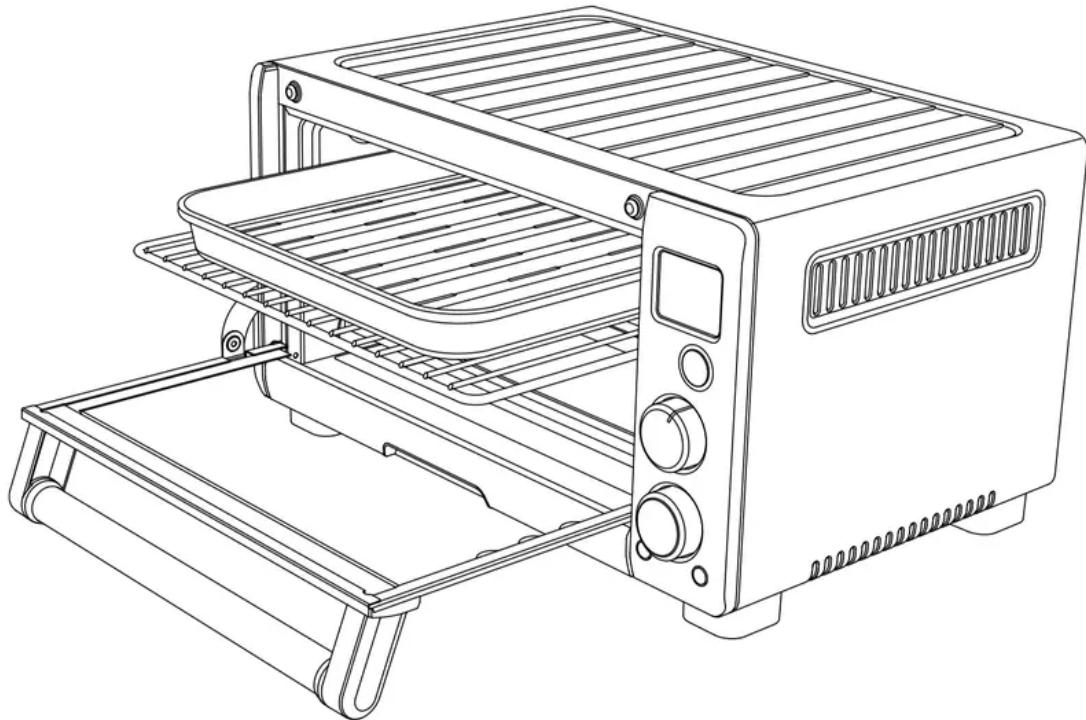

NOTE: When broiling, the Breville enamel broil rack must be inserted into the Breville enamel baking pan. When assembled together, the broil rack is designed to drain grease and fats away from meats for healthier cooking. The baking pan collects these pan drippings and helps prevent spattering.

NOTE: Caution should be exercised when using metal foil to cover accessories, pans, and dishes. Be sure that the metal foil is fitted securely as close contact with the oven's heating elements can cause overheating and risk of fire.

NOTE: When using metal foil to cover accessories, pans, and dishes, it is recommended that the wire rack be in the middle or bottom location.

NOTE: Caution should be exercised when using pans and dishes constructed of materials other than metal. If using ceramic or glass pans or dishes it is important that they are oven safe to prevent cracking.

NOTE: Caution should be exercised when using lids in the oven, as pressure build up in a covered pan or dish may cause hot ingredients to expel or the dish to crack.

3. Close the oven door. **IMPORTANT:** Always ensure the oven door is completely Closed when using the BROIL function.

4. Turn the FUNCTION dial until the indicator reaches the BROIL function. The LCD screen indicates the preset BROIL temperature of 'HI'.

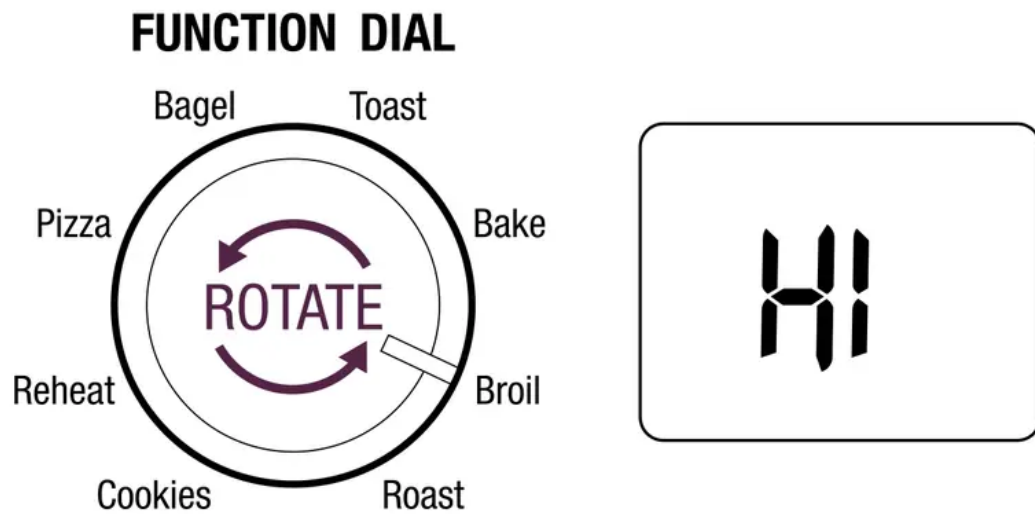

5. The broiling temperature and time can be adjusted before or during the broiling cycle.
- a) The preset 'HI' is displayed as default broiling temperature on the LCD screen. To select the broiling temperature, turn the TEMP/TIME dial to select either 'HI' (high) or 'LO' (low).

NOTE: The two preset broiling temperatures allow you to change the broiling speed – how quickly the tops of your food brown - depending on the food to be broiled, quantity of food & your personal taste. While we suggest most foods should be broiled using the preset 'HI', we recommend experimenting with the broiling temperature and time settings to produce the desired results.

- b) To select the broiling time, press the center of the TEMP/TIME dial until the LCD screen displays the preset Broiling time of ':10 MINS'.

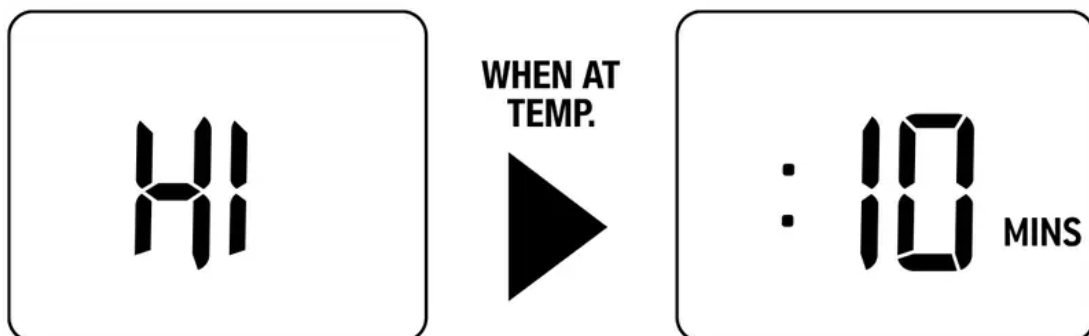

Turn the dial to adjust the Broiling time in one minute increments up to a maximum of 20 minutes.

| TYPE/CUT | WEIGHT/ THICKNESS | BROILING TIME |
|--|-----------------------------------|-------------------------------|
| Beef Sirloin Hamburger | 1" (2.5cm) 1" (2.5cm) | 12-15 mins 10-15 mins |
| Pork Chops Ribs Bacon | 1" (2.5cm) 1 rack 3 rashers | 15 mins 20 mins 10 mins |
| Lamb Neck chops Cutlets | 4 pieces 8 pieces | 15 mins 10-12 mins |
| Sausages Thin Thick | 8 pieces 6 pieces | 8 mins 12 mins |
| Chicken Wings Breast or Thigh | 1lb (500g) 0.5lbs (250g) | 12-15 mins 20 mins |
| Fish | 0.5lbs (250g) 1lb (500g) | 8 mins 8-10 mins |
| Cheese Melt | | 3-5 mins |

NOTE: Your customized broil temperature and time settings will remain in the memory of

the oven until you change them or unplug the oven from the power outlet. When the oven is plugged back into the power outlet, the BROIL function will automatically return to the preset temperature of 'HI', and preset time of ':10MINS'.

6. Press the START/CANCEL button to activate this setting. The button surround will illuminate red, the oven alert will sound, and the LCD screen will illuminate orange.
7. The timer will be displayed and begin to count down in one minute increments. The temperature and time can be adjusted during the Broiling cycle by turning the TEMP/TIME dial. Toggle between the temperature and time LCD screen by pressing the center of the TEMP/TIME dial.

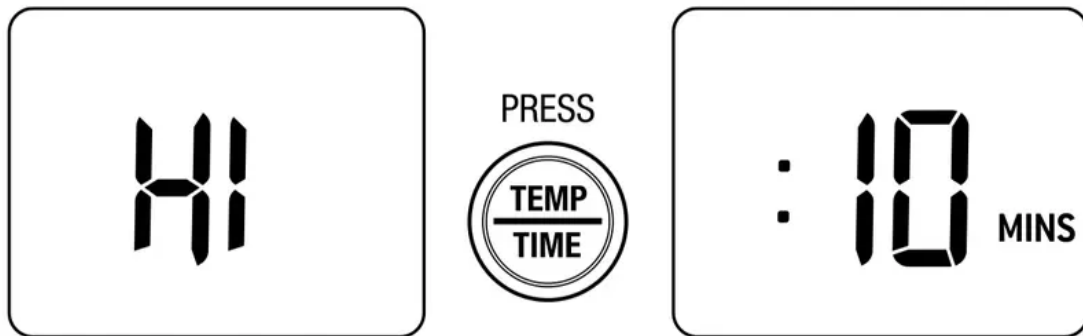

NOTE: Depending on the food being Broiled, it may be necessary to turn food over half way through the cooking time to achieve even cooking and browning.

8. At the end of the cooking cycle, the oven alert will sound three times. The START/CANCEL button surround will no longer illuminate red and LCD screen will illuminate blue. **IMPORTANT:** The outer surface of the oven, including the oven door, is hot during and after operation. Always use protective hot pads or insulated oven mitts when inserting, removing or handling items from the oven.
9. The broiling cycle can be stopped at any time by pressing the START/CANCEL button. This will cancel the cycle. The button surround illumination will go out and the LCD screen will illuminate blue.

OPERATING YOUR BREVILLE COMPACT SMART OVEN™ – PIZZA

PIZZA FUNCTION

Elements

Top and bottom heating elements cycle on and off to regulate the correct temperature.

Rack Position

Middle rack height position.

Optional Settings



FROZEN FOODS button.



TEMPERATURE CONVERSION button.

The PIZZA function melts and browns cheese and toppings, while crisping the pizza crust.

1. Insert the wire rack into the middle rack height position. The wire rack should be positioned with the spokes facing upwards. Close the oven door.

NOTE: We recommend using the middle rack height position during the PIZZA function. However this is a guide only. The position of the rack may vary depending on the type and size of the pizza. Some fresh pizza's may be more suited to the bottom rack height position. We recommend experimenting with the rack height position, as well as the temperature and time settings to produce the desired results.

NOTE: If cooking a frozen pizza, ensure to remove all packaging, including cardboard, plastic, paper, or other flammable materials before placing the pizza in the oven. Breville recommends using a dark colored, non-stick pizza pan when cooking a pizza. Light colored pans reflect heat and may not effectively crisp the pizza crust. The optional 12" (30cm) non-stick pizza pan accessory is available. For a crisper crust, pizzas can be cooked directly on the wire rack. However care should be taken as melted cheese and other ingredients may build-up on the heating elements and create a potential fire risk.

2. Turn the FUNCTION dial until the indicator reaches the PIZZA function. The LCD screen

indicates the preset PIZZA temperature of '425°F'. The preset  FROZEN FOODS setting will also be displayed (see Page 37 if cooking fresh pizza).

FUNCTION DIAL

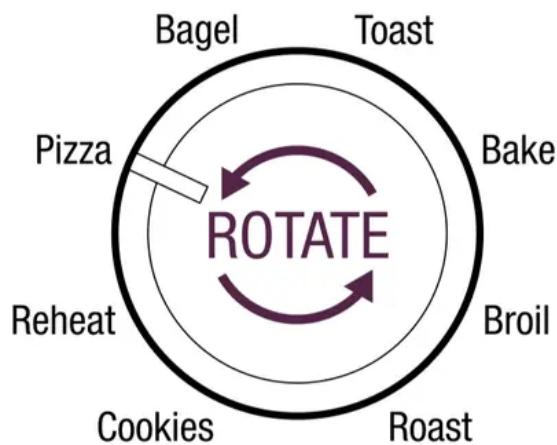

3. The pizza cooking temperature and time can be adjusted before or during the cooking cycle.

a) The preset cooking temperature of 425°F is displayed as the default on the LCD screen. Turn the TEMP/TIME dial to adjust the cooking temperature in 10°F increments, from 120°F to a maximum of 450°F (or in the Celsius mode, 5°C increments, from 50°C to a maximum 230°C).

b) To select the cooking time, press the center of the TEMP/TIME dial until the LCD

screen displays the preset cooking time of ':15 MINS'.

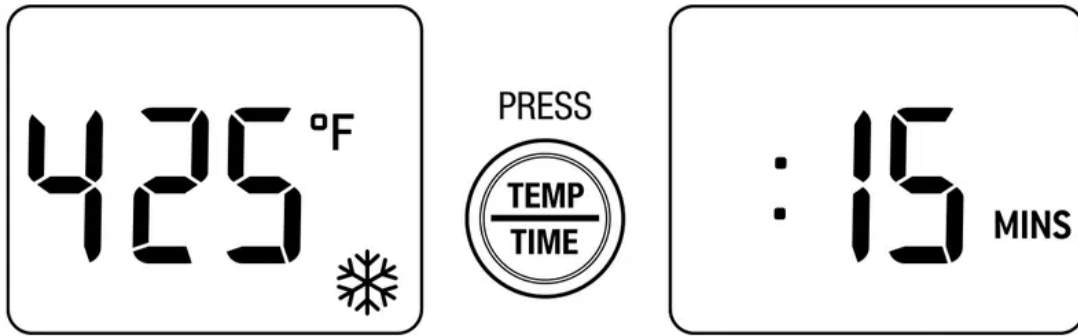

Turn the dial to adjust the cooking time in one minute increments up to 1 hour, and in 5 minute increments between 1 and 2 hours.

NOTE: The cooking technology in The Compact Smart Oven™ allows foods to cook more evenly and quickly, significantly reducing cooking times. The oven's preset cooking temperatures and times, as well as the cooking temperature and time directions on pre-packaged foods, may need to be changed depending on the recipe, the amount of food and your personal taste. We recommend experimenting with the temperature and time settings to produce the desired results.

NOTE: Due to the wide variety of pizzas available, you will need to consider whether you are cooking a fresh or frozen pizza or a thin crust or deep dish, and adjust the cooking time to produce the ideal result. For example, frozen pizzas may need additional cooking time. Thick crust pizzas may also require slightly more cooking time.

NOTE: Your customized PIZZA temperature and time settings will remain in the memory of the oven until you change them or unplug the oven from the power outlet. When the oven is plugged back into the power outlet, the PIZZA function will automatically return to

the preset temperature of 425°F (220°C), preset time of ':15 MINS' and preset  FROZEN FOODS setting.

4. Press the START/CANCEL button to activate this setting. The button surround will illuminate red, the oven alert will sound, and the LCD screen will illuminate orange.
5. The LCD screen will indicate a blinking 'PREHEATING'. Once the oven has reached the set temperature, the temperature alert will sound.

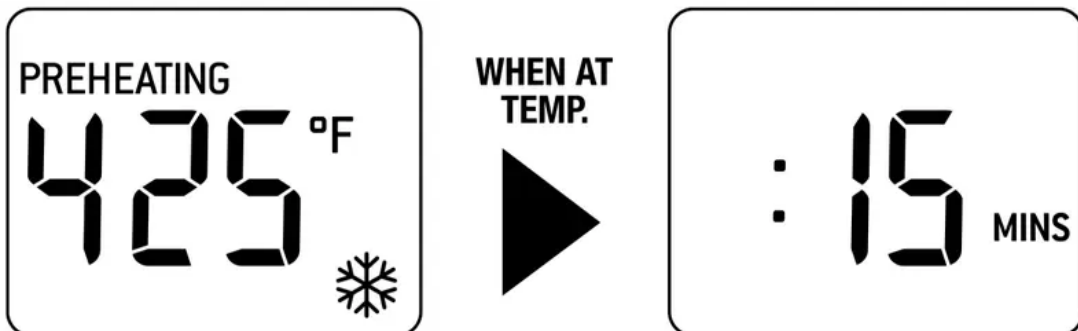

- Place the pizza pan or pizza on the wire rack so air flows around the sides of the food.
NOTE: Pizza pan color, size, and thickness can affect browning/crispiness of the pizza base.
- After the PREHEATING alert has sounded, the timer will automatically begin to count down in one minute increments. The temperature and time can be adjusted during the cooking cycle by turning the TEMP/TIME dial. Toggle between temperature and time LCD screen by pressing the center of the TEMP/TIME dial.

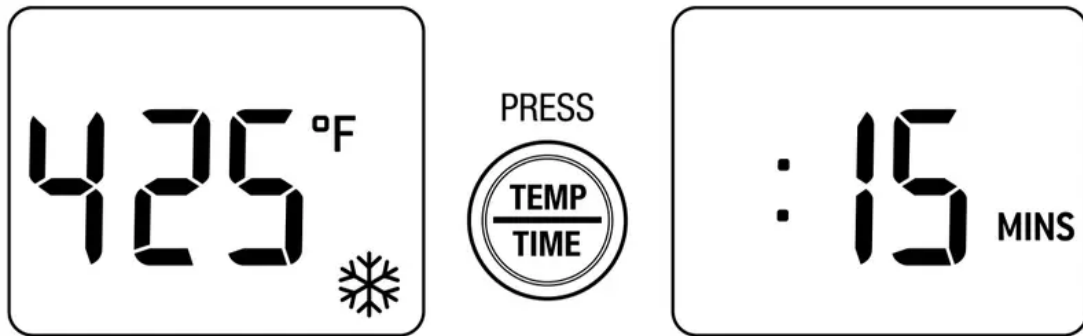

NOTE: Some large pizzas may brown unevenly in compact ovens. Open the oven door half way through the cooking time and carefully rotate the pizza 90 degrees for more even browning.

- At the end of the cooking cycle, the oven alert will sound three times, the START/CANCEL button will cease to illuminate and the LCD back light will illuminate blue.
NOTE: Be sure to use protective hot pads or insulated ovens mitts when removing the pizza from the oven as melted cheese and toppings will be hot.
- The pizza cycle can be stopped at any time by pressing the START/CANCEL button. This will cancel the cycle. The button surround illumination will go out and the LCD screen will illuminate blue.

A note on pizza stones

When using a pizza stone, it is necessary to first heat the stone (without a pizza) for optimum results.

- Insert the wire rack into the middle rack height position. The wire rack should be positioned with the spokes facing upwards.
- Place the pizza stone on the center of the wire rack so air flows around the sides of the stone.
- Close the oven door.
- Press the START/CANCEL button to activate this setting. The button surround will illuminate red, the oven alert will sound, and the LCD screen will illuminate orange.
- The LCD screen will indicate a blinking 'PREHEATING'. Once the oven has reached the set temperature, the temperature alert will sound.

6. The timer will be displayed and automatically begin to count down in one minute increments.
7. At the end of the pizza stone heating cycle, the oven alert will sound three times, the START/CANCEL button will cease to illuminate and the LCD back light will illuminate blue.
8. Now carefully place the frozen pizza on the heated pizza stone. NOTE: If cooking a fresh pizza, we recommend using protective hot pads or insulated oven mitts to remove the entire wire rack with pizza stone, and place on the open oven door or bench. This will assist in transferring the fresh pizza dough onto the heated pizza stone. Always use protective hot pads or insulated oven mitts to reinsert the wire rack with pizza stone and pizza, inside the oven.
9. Select the desired pizza setting and press the START/CANCEL button to restart the pizza cycle.

OPERATING YOUR BREVILLE COMPACT SMART OVEN™ – COOKIE

COOKIE FUNCTION

Elements

Top and bottom heating elements cycle on and off to regulate the correct temperature.

Rack Position

Middle rack height position.

Optional Settings



FROZEN FOODS button.



TEMPERATURE CONVERSION button.

The COOKIE function is ideal for baking homemade or commercially prepared cookies and other baked treats.

Ready-to-bake crescent rolls, cinnamon scrolls, biscuits and strudels are ideally baked using this function.

1. Insert the wire rack into the middle rack height position. The wire rack should be positioned with the spokes facing upwards.
2. Close the oven door.

3. Turn the FUNCTION dial until the indicator reaches the COOKIE function. The LCD screen indicates the preset temperature of '350°F'.

FUNCTION DIAL

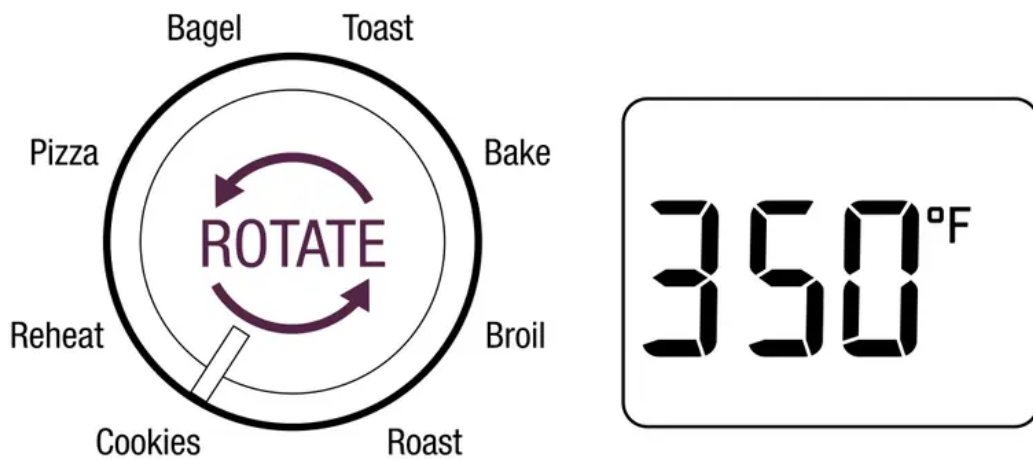

4. The baking temperature and time can be adjusted before or during the baking cycle.
- The preset baking temperature of 350°F is displayed as the default on the LCD screen. Turn the TEMP/TIME dial to adjust the baking temperature in 10°F increments, from 120°F to a maximum of 450°F (or in the Celsius mode, 5°C increments, from 50°C to a maximum 230°C).
 - To select the baking time, press the center of the TEMP/TIME dial until the LCD screen displays the preset baking time of : '11 MINS'.

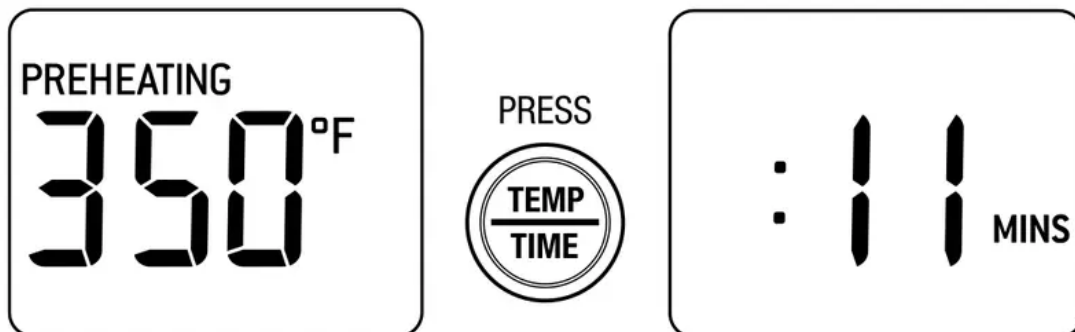

Turn the dial to adjust the cooking time in one minute increments up to a maximum of 1 hour.

NOTE: Due to the wide variety of cookie types, you will need to consider whether you're baking fresh, refrigerated or frozen cookie dough, and adjust the baking time to produce the ideal result. For example, frozen cookie dough may need additional baking time. The amount of dough per cookie or the thickness of the cookie may also vary the cooking time.

NOTE: Your customized COOKIE temperature and time settings will remain in the memory of the oven until you change them or unplug the oven from the power outlet. When the oven is plugged back into the power outlet, the COOKIE function will automatically return to the preset temperature of 350°F (175°C), and preset time of ':11 MINS'.

5. Press the START/CANCEL button to activate this setting. The button surround will illuminate red, the oven alert will sound, and the LCD screen will illuminate orange.
6. The LCD screen will indicate a blinking 'PREHEATING'. Once the oven has reached the set temperature, the temperature alert will sound.

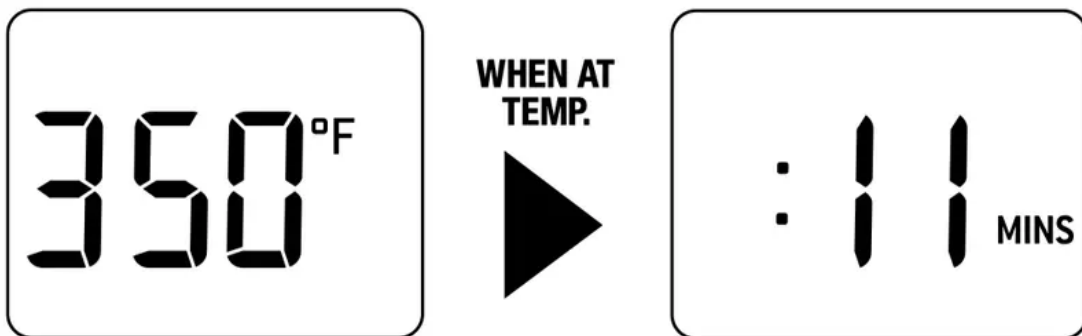

7. Place food on the Breville enamel baking pan or in an oven-proof pan, then place on the center of the wire rack so air flows around the back, as well as the front of the food.

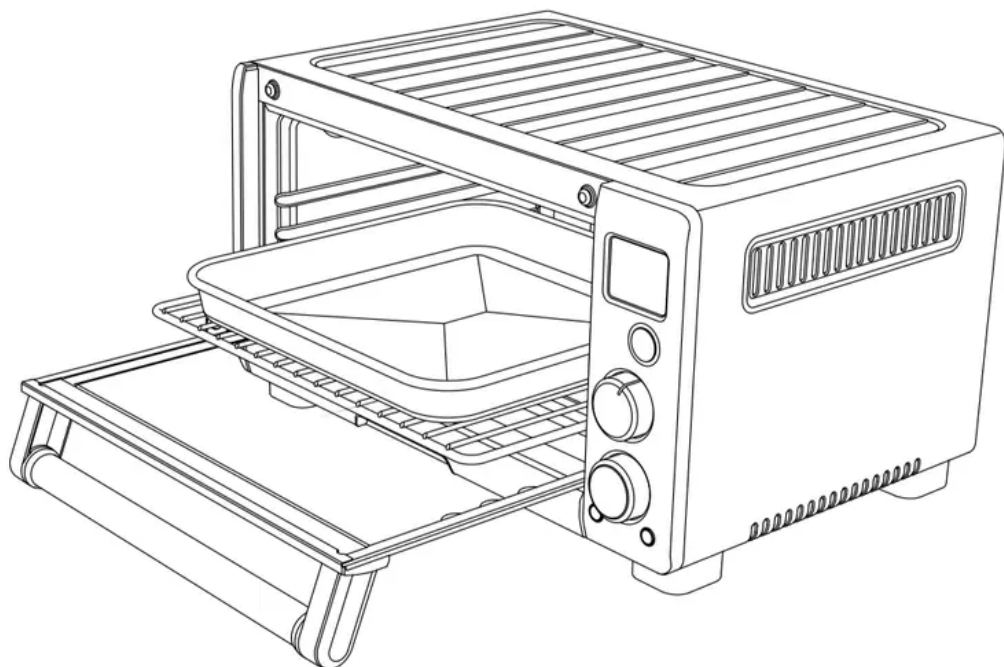

NOTE: It may be necessary to lightly grease or line the enamel baking pan with baking paper to prevent cookies from sticking.

NOTE: Caution should be exercised when using metal foil to cover accessories, pans, and dishes. Be sure that the metal foil is fitted securely as close contact with the oven's heating elements can cause overheating and risk of fire.

NOTE: When using metal foil to cover accessories, pans, and dishes, it is recommended that the wire rack be in the middle or bottom location.

NOTE: Caution should be exercised when using pans and dishes constructed of materials other than metal. If using ceramic or glass pans or dishes it is important that they are oven safe to prevent cracking.

NOTE: Caution should be exercised when using lids in the oven, as pressure build up in a covered pan or dish may cause hot ingredients to expel or the dish to crack.

8. After the PREHEATING alert has sounded, the timer will automatically begin to count down in one minute increments. The temperature and time can be adjusted during the baking cycle by turning the TEMP/TIME dial. Toggle between Temperature and Time by pressing the TEMP/TIME button.

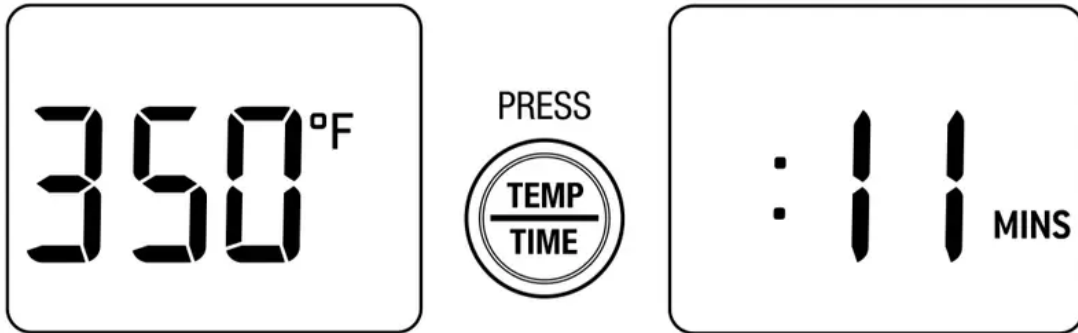

9. At the end of the baking cycle, the oven alert will sound three times, the START/CANCEL button will cease to illuminate and the LCD screen will illuminate blue.

IMPORTANT: The outer surface of the oven, including the oven door, is hot during and after operation. Always use protective hot pads or insulated oven mitts when inserting, removing or handling items from the oven.

10. The baking cycle can be stopped at any time by pressing the START/CANCEL button. This will cancel the cycle. The button surround illumination will go out and the LCD screen will illuminate blue.

OPERATING YOUR BREVILLE COMPACT SMART OVEN™ – REHEAT

REHEAT FUNCTION

Elements

Top and bottom heating elements cycle on and off to regulate the correct temperature.

Rack Position

Bottom rack height position.

Optional Settings



TEMPERATURE CONVERSION button.

The REHEAT function is ideal for reheating leftovers without browning.

1. Insert the wire rack into the bottom rack height position. The wire rack should be positioned with the spokes facing upwards.
2. Place food on the Breville enamel baking pan or in an oven-proof dish, then place on the center of the wire rack so air flows around the sides of the food.

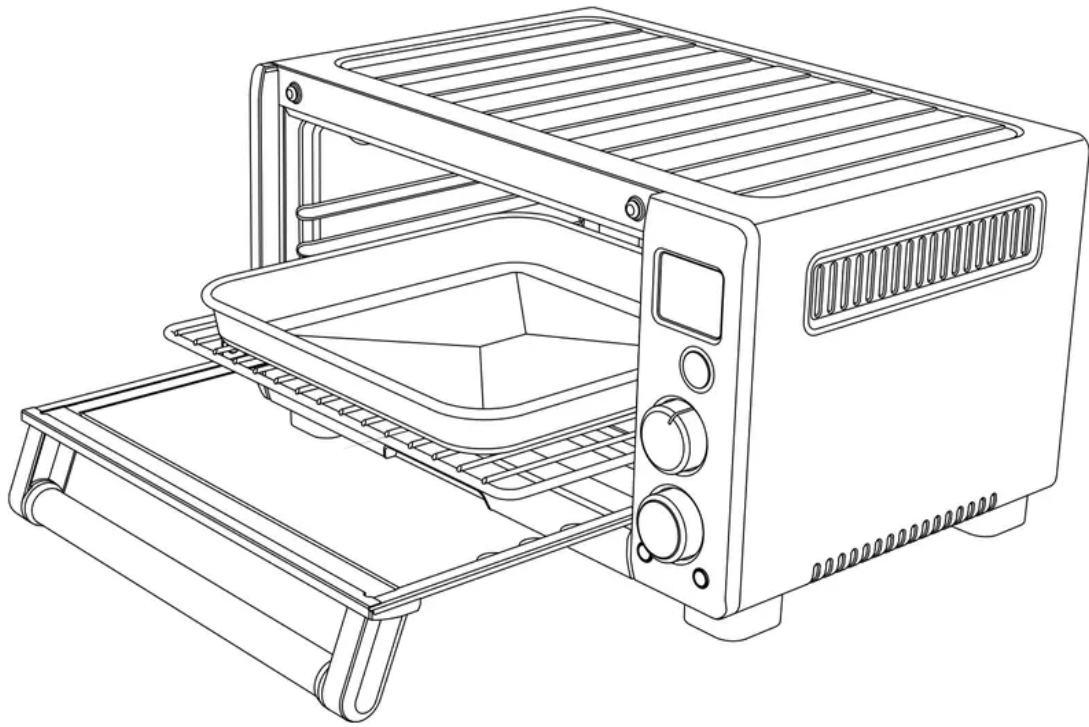

NOTE: Caution should be exercised when using metal foil to cover accessories, pans, and dishes. Be sure that the metal foil is fitted securely as close contact with the oven's heating elements can cause overheating and risk of fire.

NOTE: When using metal foil to cover accessories, pans, and dishes, it is recommended that the wire rack be in the middle or bottom location.

NOTE: Caution should be exercised when using pans and dishes constructed of materials other than metal. If using ceramic or glass pans or dishes it is important that they are oven safe to prevent cracking.

NOTE: Caution should be exercised when using lids in the oven, as pressure build up in a covered pan or dish may cause hot ingredients to expel or the dish to crack.

3. Close the oven door.

4. Turn the FUNCTION dial until the indicator reaches the REHEAT function. The LCD screen indicates the preset temperature of '325°F'.

FUNCTION DIAL

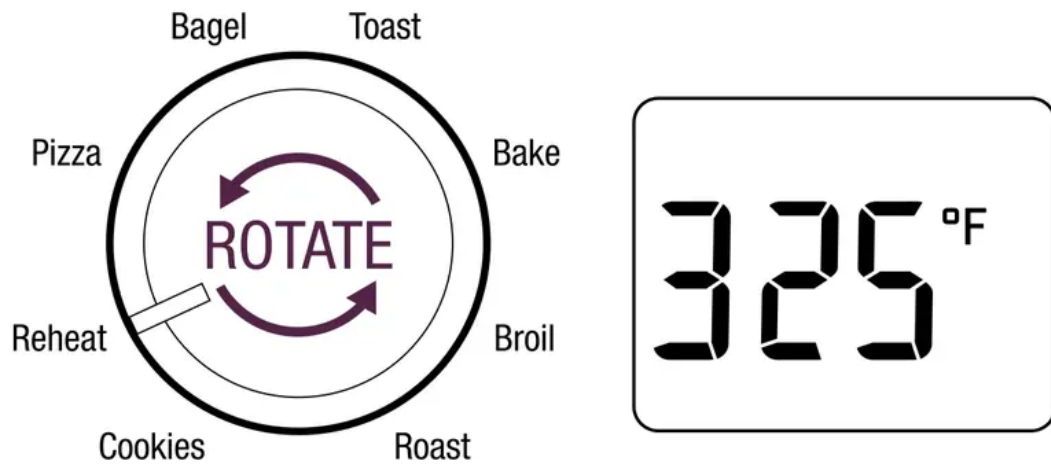

5. The reheating temperature and time can be adjusted before or during the reheating cycle.
- The preset reheating temperature of 325°F is displayed as the default on the LCD screen. Turn the TEMP/TIME dial to adjust the cooking temperature in 10°F increments, from 120°F to a maximum of 450°F (or in the Celsius mode, 5°C increments, from 50°C to a maximum 230°C).
 - To select the reheating time, press the center of the TEMP/TIME dial until the LCD screen displays the preset reheating time of ':15 MINS'.

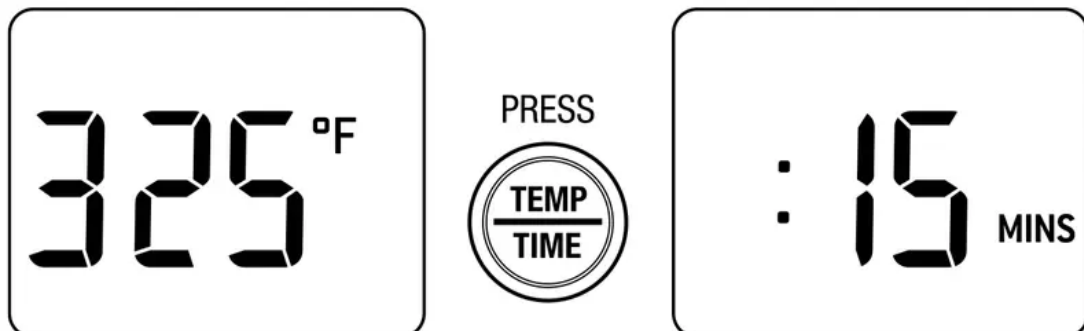

Turn the dial to adjust the cooking time in one minute increments up to a maximum of 1 hour.

NOTE: Your customized REHEAT temperature and time settings will remain in the memory of the oven until you change them or unplug the oven from the power outlet. When the oven is plugged back into the power outlet, the REHEAT function will automatically return to the preset temperature of '325°F', preset time of ':15 MINS'.

6. Press the START/CANCEL button to activate this setting. The button surround will illuminate red, the oven alert will sound, and the LCD screen will illuminate orange.

7. The timer will be displayed and begin to count down in one minute increments. The temperature and time can be adjusted during the reheating cycle by turning the corresponding TEMP/TIME dial.
8. At the end of the reheating cycle, the oven alert will sound three times, the START/CANCEL button will cease to illuminate and the LCD back light will illuminate blue.
IMPORTANT: The outer surface of the oven, including the oven door, is hot during and after operation. Always use protective hot pads or insulated oven mitts when inserting, removing or handling items from the oven.
9. The reheating cycle can be stopped at any time by pressing the START/CANCEL button. This will cancel the cycle. The button surround illumination will go out and the LCD screen will illuminate blue.

USING THE PLATE WARMING TRAY

The top of the oven is very hot during and after operation. Do not store any item on top of the oven when in operation.

The only exceptions are:

- One layer of ceramic plates for warming.
- The (optional) Bamboo Cutting Board accessory provided by Breville for use in the ribbed section on top of the oven. Visit breville.com.au for more information and refer to the Accessories Card enclosed.

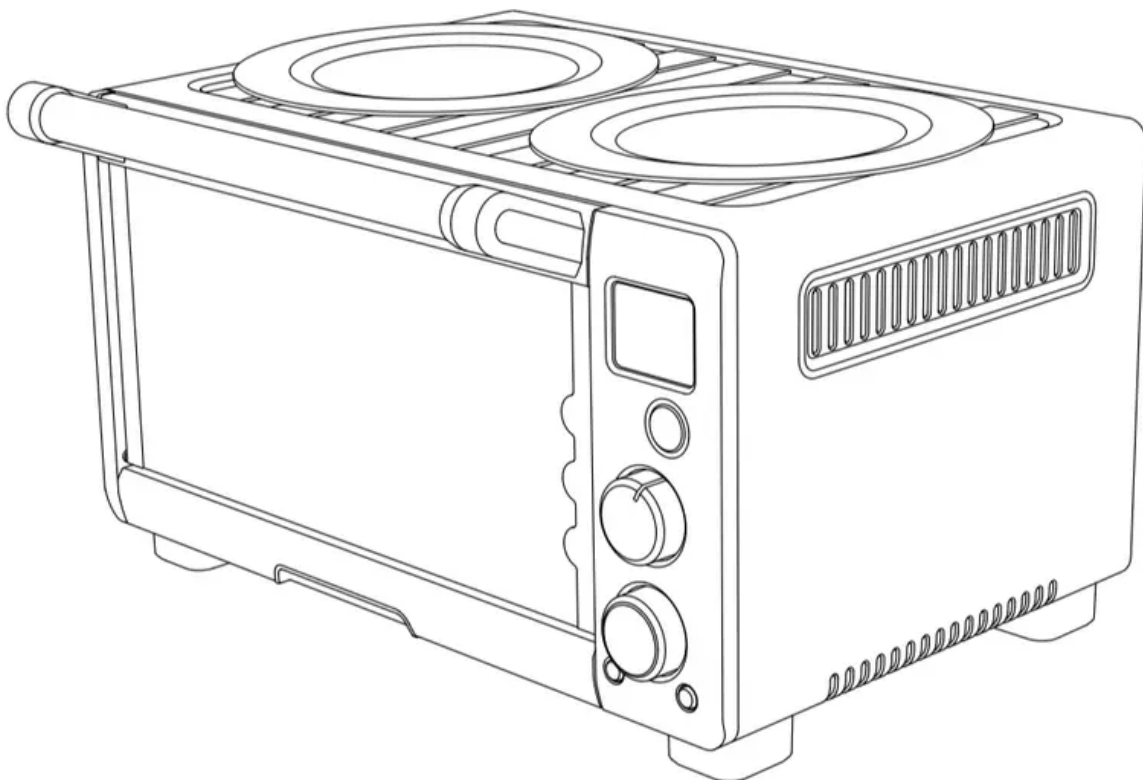

IMPORTANT: The use of any accessory attachments not recommended by Breville may cause injuries.

IMPORTANT: The outer surface of the oven, including the oven door, is hot during and after operation. Always use protective hot pads or insulated oven mitts when inserting, removing or handling items from the oven. Alternatively, allow the oven to cool down before handling.

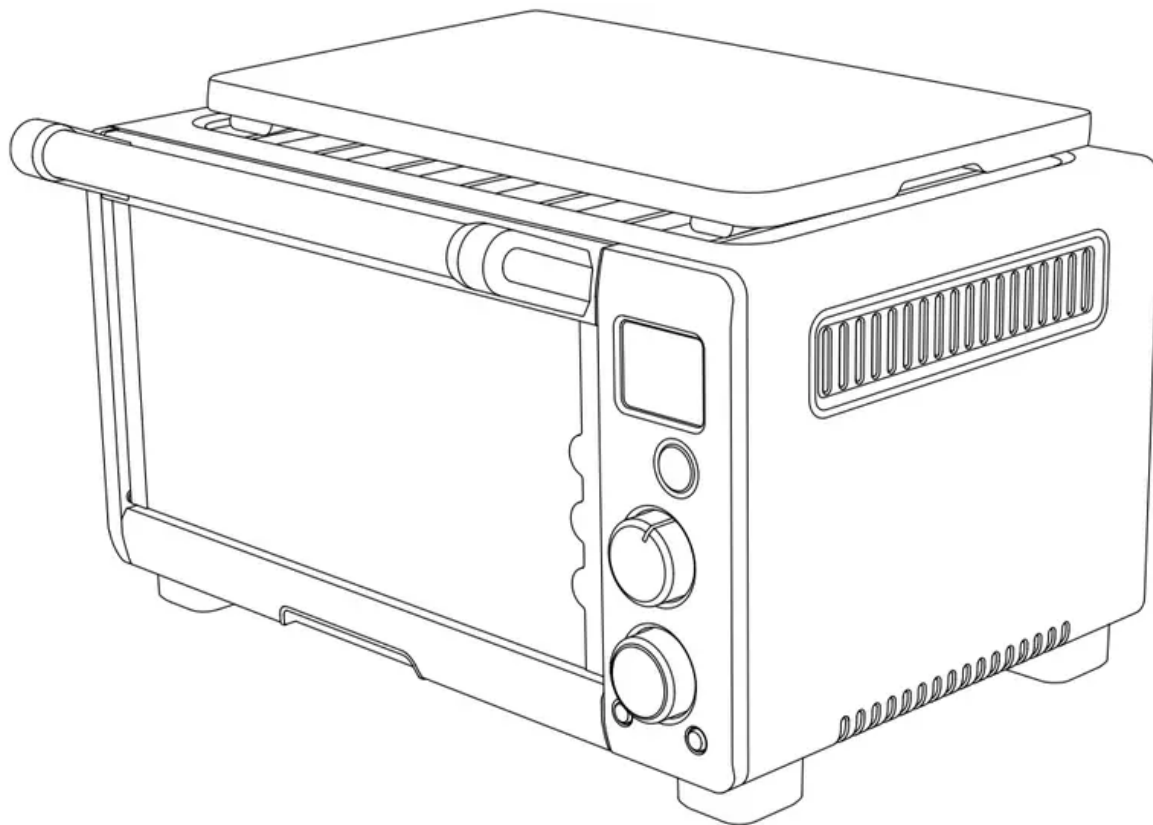

CARE & CLEANING

CARE & CLEANING YOUR BREVILLE COMPACT SMART OVEN™

Ensure the oven is turned OFF by pressing the START/CANCEL button on the control panel. The oven is OFF when the button surround illumination is no longer red. Remove the power plug from the power outlet. Allow the oven and all accessories to cool completely before disassembling and cleaning.

NOTE:

- Do not use abrasive cleansers, metal scouring pads or metal utensils on any of the interior or exterior surfaces of the oven, including the crumb tray.
- Do not use abrasive cleansers, metal scouring pads or metal utensils to clean any of the accessories as they may damage the porcelain enamel finish of the baking pan and broiling rack.

Cleaning the outer body and door

1. Wipe the outer body with a soft, damp sponge. A non-abrasive liquid cleanser or mild spray solution may be used to avoid build-up of stains. Apply the cleanser to the sponge, not the oven surface, before cleaning.
2. To clean the glass door, use a glass cleaner or mild detergent and a soft, damp sponge or soft plastic scouring pad. Do not use an abrasive cleanser or metal scouring pad as these will scratch the oven surface.
3. Let all surfaces dry thoroughly prior to inserting the power plug into a power outlet and turning the oven ON.

IMPORTANT: Do not immerse the body, power cord or power plug in water or any other liquid as this may cause electrocution.

Cleaning the interior

1. The walls on the inside of the oven feature a non-stick coating for easy cleaning. To clean any spattering that may occur, wipe the walls with a soft, damp sponge. A non-abrasive liquid cleanser or mild spray solution may be used to avoid build-up of stains. Apply the cleanser to the sponge, not the oven surface, before cleaning. Avoid touching the quartz heating elements.

IMPORTANT: Use extreme caution when cleaning the quartz heating elements. Allow the oven to cool completely, then gently rub a soft, damp sponge or cloth along the length of the heating element. Do not use any type of cleanser or cleaning agent. Let all surfaces dry thoroughly prior to inserting the power plug into a power outlet and turning the oven ON.

2. Let all surfaces dry thoroughly prior to inserting the power plug into a power outlet and turning the oven ON.

Cleaning the crumb tray

1. After each use, slide out the crumb tray and discard crumbs. Wipe the tray with a soft, damp sponge. A non-abrasive liquid cleanser may be used to avoid build-up of stains. Apply the cleanser to the sponge, not the tray, before cleaning. Dry thoroughly.
2. To remove baked-on grease, soak the tray in warm soapy water then wash with a soft sponge or soft plastic scouring pad. Rinse and dry thoroughly.
3. Always ensure to re-insert the crumb tray into the oven after cleaning and prior to inserting the power plug into a power outlet and turning the oven ON.

Cleaning the wire rack, broil rack and baking pan.

1. Wash all accessories in warm soapy water with a soft sponge or soft plastic scouring pad. Rinse and dry thoroughly.

2. To extend the life of your accessories, we do not recommend that these be placed in the dishwasher.

Storage

1. Ensure the oven is turned OFF by pressing the START/CANCEL button on the control panel. The oven is OFF when the button surround illumination is no longer red. Then remove the power plug from the power outlet.
2. Allow the oven and all accessories to cool completely.
3. Ensure the oven and all accessories are clean and dry.
4. Ensure the crumb tray is inserted into the oven, the broil rack is inserted into the baking pan and resting on the wire rack in the middle rack height position.
5. Ensure the door is closed.
6. Store the appliance in an upright position standing level on its support legs. Do not store anything on top and inside oven except the accessories.

NOTE: Citric acid, found in foods such as orange, lemon and lime juice, may damage the porcelain enamel finish of the baking pan and broiling rack. When cooking foods with high citric acid content, we strongly recommend lining the enamel surfaces with foil or baking paper to extend the life of these accessories.

TROUBLESHOOTING



| PROBLEM | EASY SOLUTION |
|---|---|
| Oven will not switch "ON" | <ul style="list-style-type: none"> • Check that the power plug is securely inserted into the power outlet • Insert the power plug into an independent power outlet • Insert the power plug into a different outlet • Reset the circuit breaker if necessary |
| I would like to have the oven LCD default settings back | <ul style="list-style-type: none"> • The oven will remember the last setting used for each function unless you remove the power plug from the power outlet. • To restore the oven's default settings for each function, remove the power plug from the power outlet. Wait 5 seconds, then plug back in. |
| The LCD display light has gone out | <ul style="list-style-type: none"> • The oven goes into STANDBY mode if not used for 10 minutes. When in STANDBY mode, the LCD screen will cease to illuminate, however 'STANDBY' will still be visible. • To re-activate the oven out of STANDBY mode, press the START/CANCEL button on the control panel, or turn any dial. The LCD screen will re-illuminate. |
| The pizza does not cook evenly | <ul style="list-style-type: none"> • Some large pizzas may brown unevenly in compact ovens. Open the oven door half way through the cooking time and turn the pizza 90 degrees for more even browning. |
| The pizza crust does not crisp | <ul style="list-style-type: none"> • Breville recommends using a dark colored, non-stick pizza pan when cooking a pizza. Light colored pans reflect heat and may not effectively crisp the pizza crust. • For a crisper crust, pizzas can be cooked directly on the wire rack. However care should be taken as melted cheese and othering redients may build-up on the heating elements and create a potential fire risk. |



| PROBLEM | EASY SOLUTION |
|---|---|
| I cannot select the FROZEN FOODS button | <ul style="list-style-type: none"> The FROZEN FOODS button is only selectable during the TOAST, BAGEL, BAKE, PIZZA and COOKIE functions. |
| Steam is coming out from the top of the oven door | <ul style="list-style-type: none"> This is normal. The door is vented to release steam created from high-moisture content foods such as frozen breads. |
| Water is dripping onto bench top from under door | <ul style="list-style-type: none"> This is normal. The condensation created from high moisture content foods such as frozen breads will run down the inside of the door and can drip onto the bench. |
| The heating elements appear to be pulsing | <ul style="list-style-type: none"> Element IQ™ accurately controls the heat inside the oven by pulsing the power in the heating elements in short bursts. This is normal. |
| The temperature reading on the LCD screen doesn't match the temperature measured inside the oven. | <ul style="list-style-type: none"> To ensure the measurements are standardized, the oven temperatures have been calibrated in the TOAST position (center of the middle rack with no tray in place). Re-check the temperature in this position, ensuring not to open the oven door for 10 minutes as heat will escape each time the door is opened. Note that the 'preheat' alert sounds at 75% of the target temperature. See below for full explanation. |
| The 'preheat' alert sounds at a lower temperature than what is displayed on the LCD screen. | <ul style="list-style-type: none"> The 'preheat' alert sounds at 75% of the target temperature. This provides the fastest, combined preheating and cooking time. This is because when the 'preheating' alert sounds, signaling the user to open the oven door and insert food, there is dramatic temperature loss inside the oven. If the alert sounded at 100% of the target temperature, opening the door would mean a lot of this waiting time is "wasted". We have calculated that by sounding the alert at 75% of the target temperature, followed by the oven door being opened to place food inside the oven, that we still recover to the target |



| PROBLEM | EASY SOLUTION |
|--------------------------------------|---|
| | <p>temperature up to 2 minutes faster. This is why the temperature on the LCD screen does not match the target temperature at the 'preheat' alert. In total, it takes the oven approximately 8-10 minutes from start-up, including opening the oven door when the 'preheat' alert sounds, to reach the target temperature. To ensure the fastest heat up time, the Breville oven uses the maximum allowable power from the outlet (1500W for baking, 1800W for toasting).</p> |
| <p>The LCD screen displays 'E01'</p> | <ul style="list-style-type: none"> • The LCD screen will display 'E01' when there is a non-resettable issue with the appliance. Should this occur, immediately remove the power cord from the wall outlet and call the Breville Customer Service Center (1-866-BREVILLE). |
| <p>The LCD screen Displays 'E02'</p> | <ul style="list-style-type: none"> • The LCD screen will display 'E02' when there is a non-resettable issue with the appliance. Should this occur, immediately remove the power cord from the wall outlet and call the Breville Customer Service Center (1-866-BREVILLE). |
| <p>The LCD screen Displays 'E03'</p> | <ul style="list-style-type: none"> • The LCD screen will display 'E03' if the oven temperature is above the set maximum limit. Remove the plug from the wall outlet, allow the oven to cool for 15 minutes, then plug back in. • Call Breville Customer Service (1-866-BREVILLE) if the 'E03' message continues. |
| <p>The LCD screen Displays 'E04'</p> | <ul style="list-style-type: none"> • The LCD screen will display 'E04' if the room temperature is below the set minimum. Unplug the oven and relocate to a warmer area. |



| PROBLEM | EASY SOLUTION |
|----------------------------------|---|
| The LCD screen Displays 'E05' | <ul style="list-style-type: none"><li data-bbox="608 271 1321 479">• The LCD screen will display 'E05' when there is a non-resettable issue with the appliance. Should this occur, immediately remove the power cord from the wall outlet and call the Breville Customer Service Center (1-866-BREVILLE). |

Warning

This content is compiled from multiple sources and is provided for reference purposes only. It may not be complete or fully applicable to all situations. If you are unable to resolve your issue, please contact the product manufacturer or an authorized service provider for official support.

