

User manual Electric Range

Surface Units

WARNING FIRE HAZARD: Never leave the range unattended with the cooktop on medium or high settings.

Keep flammable items away from the cooktop. Turn off all controls when done cooking. Failure to follow these instructions can result in fire, serious injury or death.

Throughout this manual, features and appearance may vary from your model.

How to Set

Push the knob in and turn in either direction to the setting you want.

A surface ON indicator light will glow when any surface unit is on.

For glass cooktop surfaces:

A HOT COOKTOP indicator light will:

Come on when the unit is hot to the touch.

Stay on even after the unit is turned off.

Stay on until the unit is cooled to approximately 150°F.

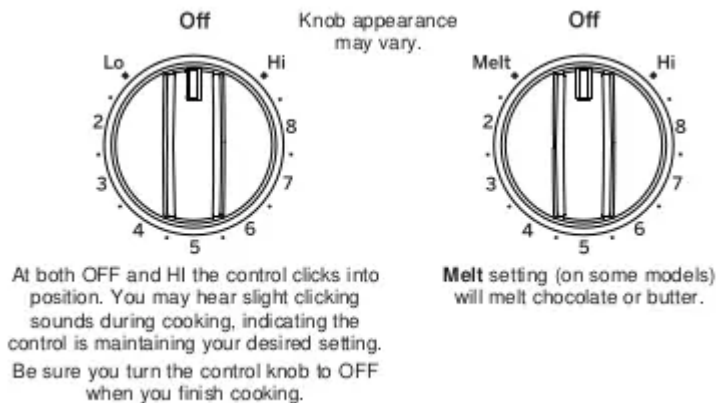

Dual and Triple Surface Units and Control Knobs (on some models)

The surface unit has 2 or 3 cooking sizes to select from so you can match the size of the unit to the size of the cookware you are using.

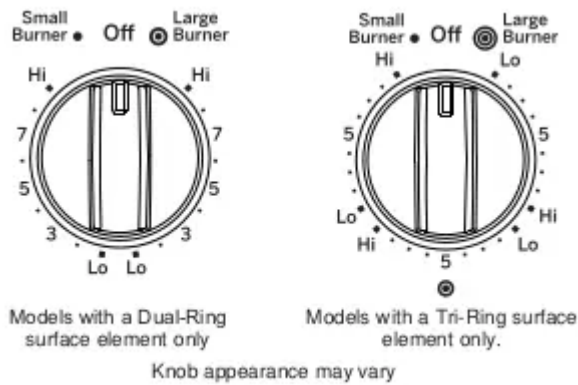

Using the Warming Zone (on some models)

FOOD POISON HAZARD:

Bacteria may grow in food at temperatures below 140°F.

- Always start with hot food. Do not use warm setting to heat cold food
- Do not use warm setting for more than 2 hours.

The WARMING ZONE, located in the back center of the glass surface, will keep hot, cooked food at serving temperature. Always start with hot food. Do not use to heat cold food. Placing uncooked or cold food on the WARMING ZONE could result in foodborne illness.

Turn the control knob to the ON position

For models using the touch pads for warming zone control, see section on "Using the Oven" for additional details.

For best results, all foods on the WARMING ZONE should be covered with a lid or aluminum foil. When warming pastries or breads, the cover should be vented to allow moisture to escape.

The initial temperature, type and amount of food, type of pan, and the time held will affect the quality of the food

Always use pot holders or oven mitts when removing food from the WARMING ZONE, since cookware and plates will be hot

NOTE: The surface warmer will not glow red like the cooking elements.



Home Canning Tips

Be sure the canner is centered over the surface unit

Make sure the canner is flat on the bottom.

To prevent burns from steam or heat, use caution when canning

Use recipes and procedures from reputable sources. These are available from manufacturers such as Ball and Kerr and the Department of Agriculture Extension Service.

Flat-bottomed canners are recommended. Use of water bath canners with rippled bottoms may extend the time required to bring the water to a boil.

For Models With a Radiant Glass Cooktop

The radiant cooktop features heating units beneath a smooth glass surface.

NOTE: A slight odor is normal when a new cooktop is used for the first time. It is caused by the heating of new parts and insulating materials and will disappear in a short time.

NOTE: On models with light-colored glass cooktops, it is normal for the cooking zones to change color when hot or cooling down. This is temporary and will disappear as the glass cools to room temperature.

The surface unit will cycle on and off to maintain your selected control setting.

It is safe to place hot cookware on the glass surface even when the cooktop is cool.

Even after the surface units are turned off, the glass cooktop retains enough heat to continue cooking. To avoid overcooking, remove pans from the surface units when the food is cooked. Avoid placing anything on the surface unit until it has cooled completely

- Water stains (mineral deposits) are removable using the cleaning cream or full-strength white vinegar.
- Use of window cleaner may leave an iridescent film on the cooktop. The cleaning cream will remove this film

- Don't store heavy items above the cooktop. If they drop onto the cooktop, they can cause damage
- Do not use the surface as a cutting board.



Never cook directly on the glass.
Always use cookware.



Always place the pan in the center of the
surface unit you are cooking on.



Do not slide cookware across the cooktop because
it can scratch the glass—the glass is scratch-
resistant, not scratch proof.

Temperature Limiter on Radiant Glass Cooktops

Every radiant surface unit has a temperature limiter.

The temperature limiter protects the glass cooktop from getting too hot.

The temperature limiter may cycle the surface units off for a time if

- the pan boils dry.
- the pan bottom is not flat
- the pan is off-center.
- there is no pan on the unit

Cookware for Radiant Glass Cooktop

The following information will help you choose cookware which will give good performance on glass cooktops.

NOTE: Follow all cookware manufacturer's recommendations when using any type of cookware on the ceramic cooktop.

Recommended

Stainless Steel

Aluminum: heavy weight recommended

Good conductivity. Aluminum residues sometimes appear as scratches on the cooktop but can be removed if cleaned immediately. Because of its low melting point, thin weight aluminum should not be used.

Copper Bottom: Copper may leave residues which can appear as scratches. The residues can be removed, as long as the cooktop is cleaned immediately. However, do not let these pots boil dry. Overheated metal can bond to glass cooktops. An overheated copper bottom pot will leave a residue that will permanently stain the cooktop if not removed immediately.

Enamel (painted) on Cast Iron: recommended if bottom of pan is coated

Avoid/Not Recommended

Enamel (painted) on Steel: Heating empty pans can cause permanent damage to cooktop glass.

The enamel can melt and bond to the ceramic cooktop.

Glass-ceramic: Poor performance. Will scratch the surface.

Stoneware: Poor performance. May scratch the surface.

Cast Iron: specifically for glass cooktops

Poor conductivity and slow to absorb heat. Will scratch the cooktop surface.

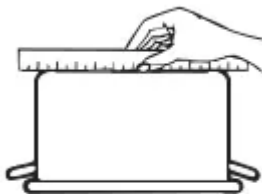

Check pans for flat bottoms by using a straight edge.



Pans with rounded, curved, ridged or warped bottoms are not recommended.

For Best Results

- Place only dry pans on the surface elements. Do not place lids on the surface elements, particularly wet lids. Wet pans and lids may stick to the surface when cool.
- Do not use woks that have support rings. This type of wok will not heat on glass surface elements.
- We recommend that you use only a flat-bottomed wok. They are available at your local retail store. The bottom of the wok should have the same diameter as the surface element to ensure proper contact.
- Some special cooking procedures require specific cookware such as pressure cookers or deep-fat fryers. All cookware must have flat bottoms and be the correct size.



Do not place wet pans on the glass cooktop.



Do not use woks with support rings on the glass cooktop.



Use flat-bottomed woks on the glass cooktop.

WiFi Connect

Your oven is designed to provide you with two-way communication between your appliance and smart device. By using the WiFi Connect features, you will be able to control essential oven operations such as temperature settings, timers and cooking modes using your smartphone or tablet.*

Select Settings then Wifi - follow the instructions on your oven display and phone app. It is necessary to turn on WiFi before using SmartHQ App on your oven.

Connecting your WiFi Connect Enabled Oven

What you will need

Your GE Appliances oven uses your existing home WiFi network to communicate between the appliance and your smart device. In order to setup your GE Appliances oven, you will need to gather some information:

1. Each GE Appliances oven has a connected appliance information label that includes an Appliance Network Name and Password. These are the two important details that you will need to connect to the appliance.

The label is typically located inside the door of the oven or drawer.

2. Have your smart phone or tablet ready with the ability to access the internet and download apps.

3. You will need to know the password of your home WiFi router. Have this password ready while you are setting up your GE Appliances oven.

Connect your GE Appliances oven

1. On your smart phone or tablet visit GEAppliances.com/connect to learn more about connected appliance features and to download the SmartHQ App.

2. Follow the app onscreen instructions to connect your GE Appliances oven.

3. Once the process is complete, the connection light located on your GE Appliances oven display will stay on solid and the app will confirm you are connected.



4. If the connection light does not turn on or is blinking, follow the instructions on the app to reconnect. If issues continue, please call the Connected Call Center 1.866.626.2000 and ask for assistance regarding oven wireless connectivity.

To connect additional smart devices, repeat steps 1 and 2.

Note that any changes or modifications to the remote enable device installed on this oven that are not expressly approved by the manufacturer could void the user's authority to operate the equipment.

REMOTE STARTING YOUR OVEN

To be able to start the oven remotely once connected to WiFi, make sure the icon is visible in the display.

The oven can now be remotely started with a connected device. Opening an oven door or turning off the oven will turn off the  icon. The  icon must be lit to start the oven remotely. The  icon is not required to change the oven temperature while it is running. Set a timer or to turn the oven off from the phone app while the WiFi icon shows it is WiFi Connected.

If you do not see the  icon, refer to the Remote Enable instructions in the Special Features section of this manual.

NOTE: sit for more than 1 hour before or after cooking. Room temperature promotes the growth of harmful bacteria. Be sure that the oven light is off because heat from the bulb will speed harmful bacteria growth.

* Compatible Apple or Android devices and home WiFi network required.

Oven Controls

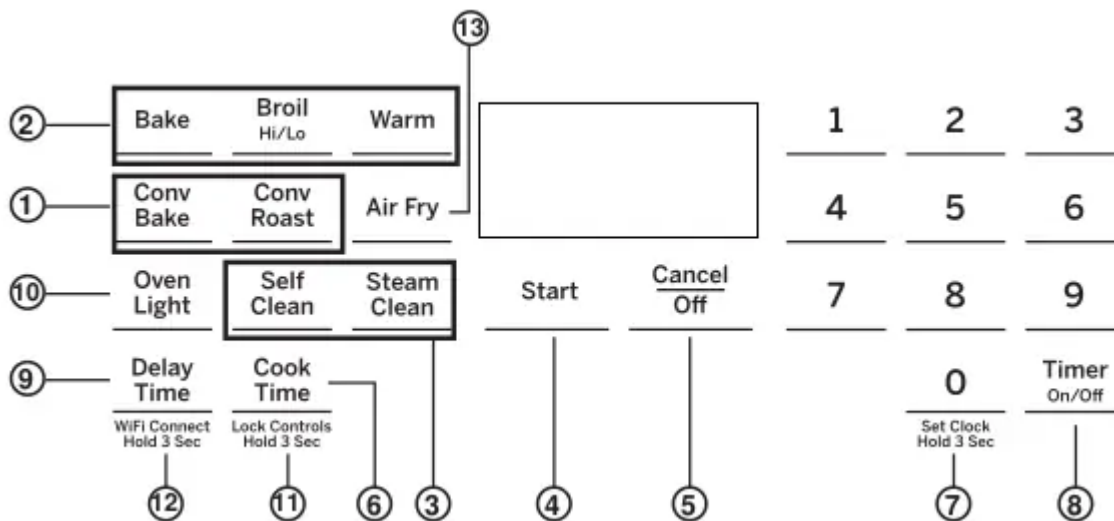

1. Convection Cooking Modes: Convection cooking modes use increased air circulation to improve performance. The type of benefit depends on the mode. Your oven has the following convection cooking modes: Convection Bake and Convection Roast. See the Cooking Modes section for more information.

2. Traditional Cooking Modes: Your oven has the following traditional cooking modes: Bake, Broil Hi/Lo, and Warm. See the Cooking Modes section for more information.

3. Clean: Your oven has two cleaning modes: Self Clean and Steam Clean. See the Cleaning the Oven section for important information about using these modes.

4. Start: Must be pressed to start any cooking, cleaning, or timed function.

5. Cancel/Off: Cancels ALL oven operations except



6. Cook Time: Counts down cooking time and turns off the oven when the cooking time is complete. Press the Cook Time pad. use the number pads to program a cooking time in hours and minutes. then press Start.

This can only be used with Bake. Convection Bake.

Convection Roast. Warm. and Air Fry.

You may use Cook Time at any point during the oven cooking cycle

7. Clock: Press and hold the 0 pad for 3 seconds to set clock.

8. Timer On/Off: Works as a countdown timer.

Press the Timer On/Off pad and the number pads to program the time in hours and minutes. Press the Start pad. The timer countdown is complete. To turn the timer off press the Timer On/Off pad.

9. Delay Time: this to set a time when you want the oven to start. Press the Delay Time pad and use the number pads to program the time of day for the oven to turn on then press Start.

Press the desired cooking mode and temperature then press Start. A Cook Time may also be programmed if desired. Follow the directions under Cook Time for setting this feature. This can only be used with Bake. Convection Bake. Convection Roast. and Self-Clean.

NOTE: When using the Delay Time feature. foods that spoil easily—such as milk. eggs. fish. stuffings. poultry land pork—should not be allowed to sit for more than. 1 hour before or after cooking. Room temperature promotes the growth of harmful bacteria. Be sure that the oven light is off because heat from the bulb will speed harmful bacteria growth.

10. Oven Light: Turns the oven light on or off.

11. Lock Controls: Locks out the control so that pressing the pads does not activate the controls. Press the Lock Controls pad. for three seconds to lock or unlock the control. Cancel/Off is always active. even when the control is locked.

12. WiFi Connect (on some models): For instructions on how to connect your oven. see the WiFi Connect section of this manual.

13. Air Fry: The Air Fry mode is designed to produce foods with a crispier exterior than traditional oven cooking. See the Oven Cooking Modes section for more information.

Special Features

There are several different special features on your range. To change the settings of these special features:

- Bake and Broil pads at the same time and hold until the special features menu is displayed.
- Use the 2 or 8 number pads to scroll through the special features until the desired feature is displayed.

- Press the 6 number pad to enter into the feature's menu and scroll through the options.
- Once the desired option is displayed. press the 6 pad to save the setting and the 4 pad to exit the menu.

Adjust the Oven Temperature (OFSt)

This feature allows the oven baking temperature to be this feature if you believe your oven temperature is too hot or too cold and wish to change it. This adjustment affects every cooking mode except broil.

Enter into the special features menu as outlined above.

Scroll through the features until "OFSt" is displayed and press 6 pad to increase the adjusted temperature or use the 8 pad to decrease the adjusted temperature. Save and exit the special features menu.

End of Timer Signals (End tonE)

This is the tone that signals the end of a timer. The tone can be either continuous (Cont) or single (bEEp).

The continuous setting (Cont) will repeatedly sound a tone every few seconds until a button on the control is pressed. A single setting (bEEp) will sound just a single tone at the end of the timer. Enter into the special features menu as outlined above. Scroll through the options until "End tonE" is displayed and press 6. Scroll through the options until the desired setting is displayed. Press 6 to save the setting and then 4 to exit the menu.

Fahrenheit or Celsius Temperature Display (Unit dEg)

The oven control is set to use Fahrenheit temperatures (F). but you can change it to use Celsius temperatures (C). Enter into the special features menu as outlined displayed and press 6. Scroll through the options until the desired setting is displayed. Press 6 to save the setting and then 4 to exit the menu.

Clock Display (CLoc diSP) displayed.

Enter into the special features menu as outlined above. Scroll through the options until "Cloc diSP" is displayed and press 6. Scroll through the

Clock Configuration (Cloc cFg) This feature specifies how the time of day will be displayed. You can select a standard 12-hour clock (12) or 24-hour military time display. Enter into the special features menu as outlined above. Scroll through the options until "Cloc cFg" is displayed and press 6. Scroll through the options until the desired setting is displayed. Press 6 to save the setting and then 4 to exit the menu.

Sound Volume (Snd)

This feature allows the oven tone volume to be adjusted on and off (oFF). Enter into the special features menu as outlined above. Scroll through the options until "sound" is displayed and press 6. Scroll through the options until the desired setting is displayed. Press

6 to save the setting and then 4 to exit the menu. The selected sound option will play once 6 is pressed.

Auto Recipe Conversion

This feature (On/Off). automatically adjusts the programmed recipe temperature in Convection Multi Bake mode. Enter into the special features menu as outlined above. Scroll through the options until "Auto rEciPE" is displayed. Scroll through the options until the desired setting is displayed. Press 6 to save the setting and then 4 to exit the menu.

NOTE: This option does not convert baking time. only temperatures. This option does not adjust temperatures for Convection Roast mode.

Remote Enable (App ENbl) (on some models)

Allows you to control your oven remotely (On/Off). Enter the special features menu as outlined above. Scroll to enter the menu and toggle the setting using the 2 or 8 key. Press the 6 key to save the setting and then 4 to exit the menu.

12-Hour Auto Shut Off (12H Shut) This feature turns off the oven after 12 hours of menu as outlined above. Scroll through the options until toggle the setting using the 2 or 8 key. Press the 6 key to save the setting and then 4 to exit the menu.

Sabbath Mode

The Sabbath mode feature complies with standards set forth by Star K. Some of these standards that will be noticed by the consumer include the disabling of tones. disabling of oven lights. and delays of about 30 seconds to one minute on display changes. Only continuous baking or timed baking is allowed in the Sabbath mode. Cooking in the Sabbath mode is a two-step process. first the Sabbath mode must be set and then the bake mode must be set.

Setting the Sabbath Mode

1. Press and hold Bake + Broil to enter special features menu.
2. Use number key 8 to navigate to "Sabb" menu. Enter the menu using number key 6.
3. Use number key 8 again to toggle the setting to ON. Use number key 6 to confirm the setting.
4. Use number key 4 to exit Special features menu.

Starting a Continuous Bake

1. Press the Bake pad.
2. If the desired temperature is 350F. press Start. If a different cooking temperature is desired. use the 1 through 5 number pads or Timer pad to select a preset cooking temperature. then press Start. Refer to the graphic below to determine which pad sets the desired cooking temperature.

After a delay, a second bracket "]" [" will appear in the display indicating that the oven is baking.

Temperature (°F)					400
1	2	3	4	5	Timer
170	200	250	300	325	On/Off
6	7	8	9	0	Lock
2h	2.5h	3h	3.5h	4h	Controls
Time (hours)					Hold 3 Sec
					6h

1 = 170° F, 2 = 200° F, 3 = 250° F, 4 = 300° F, 5 = 325° F, Timer = 400° F

6 = 2 hours, 7 = 2.5 hours, 8 = 3 hours, 9 = 3.5 hours,
0 = 4 hours, Lock Controls = 6 hours

Adjusting the Temperature

1. Press Bake. use the 1 through 5 number pads and the Timer pad to select a different preset cooking temperature. and press Start.
2. Since no feedback is given during temperature change. an oven thermometer can be used to confirm temperature changes.

Starting a Timed Bake

1. Press the Bake pad.
2. If the desired temperature is 350F. use the 6 through 0 number pads or the Lock Control pad to select a cooking time. If a cooking temperature other than 350F is desired. use the 1 through 5 number pads or the Timer pad to select a preset cooking temperature. then select the cooking time. Refer to the graphic on this page to determine which pad sets the desired cooking temperature and cooking time.
3. Press Start.

After a delay, a second bracket "]" [" will appear in the display indicating that the oven is baking. When the cook time expires. the display will change back to a single bracket "]" [" indicating that the oven is no longer baking. No tone will sound when the cook time is complete.

Exit the Sabbath Mode

Exiting the Sabbath mode should be done after the Sabbath is over.

1. Press Cancel/Off to end any bake mode that may be running.
2. Press and hold Bake + Broil to enter special features menu.
3. Use number key 8 to navigate to "Sabb" menu. Enter the menu using num key 6.
4. Use number key 8 again to toggle the setting to OFF. Use number key 6 to confirm the setting.

5. Use number key 4 to exit Special features menu.

Sabbath Mode Power Outage Note

If a power outage occurs while the oven is in Sabbath Mode, the unit will return to Sabbath Mode when power is restored, however the oven will return to the off state even if it was in the middle of a bake cycle when the power outage occurred.

Oven Racks

Recommended rack positions for various types of foods are provided in the Cooking Guide. Adjusting rack position is one way to impact cooking results. For example, if you would prefer darker tops on cakes, muffins, or cookies, try moving food one rack position higher. If you find foods are too brown on top try moving them down next time.

When baking with multiple pans and on multiple racks, ensure there is at least 1½" between pans to allow sufficient space for air to flow.

Your Oven may have extension racks and/or traditional flat racks.

To avoid possible burns, place the racks in the desired position before you turn the oven on.

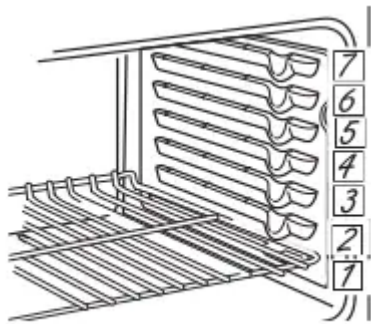

The number of rack positions may vary by model.

Aluminum Foil and Oven Liners

Do not use any type of foil or oven liner to cover the oven bottom. These items can trap heat or melt, resulting in damage to the product and risk of shock, smoke or fire. Damage from improper use of these items is not covered by the product warranty.

Foil may be used to catch spl by placing a sheet on a lower rack, several inches below the food. Do not use more foil than necessary and never entirely cover an oven rack with aluminum foil. Keep foil least 1-1/2" from oven walls to prevent poor heat circulation.

Oven Cookware

Cookware Guidelines

The material, finish, and size of cookware affect baking performance.

Dark, coated and dull pans absorb heat more readily than light, shiny pans. Pans that absorb heat more readily can result in a browner, crisper, and thicker crust, fusing dark and

coated cookware check food earlier than minimum cook time. If undesirable results are obtained with this type of cookware consider reducing oven temperature by 25°F next time.

Shiny pans can produce more evenly cooked baked goods such as cakes and cookies.

Glass and ceramic pans heat slowly but retain heat well These types of pans work well for dishes such as pies and custards.

Air insulated pans heat slowly and can reduce bottom browning

Keep cookware clean to promote even heating.

Stoneware heats slowly and retains heat well. It is recommended to preheat this type of cookware if possible. Additional cook time may be required.

Cookware used in broil modes and air fry must be broil-safe.

Cooking Modes

Your new oven has a variety of cooking modes to help you get the best results. These modes are described below. Refer to the Cooking Guide section for rack position and other recommendations for specific modes and foods. Remember, your new oven may perform differently than the oven it is replacing.

Baking and Roasting Modes

Select a mode for baking and roasting based on the type and quantity of food you are preparing. When preparing baked goods such as cakes, cookies, and pastries always preheat the oven first. Follow recipe recommendations for food placement. If no guidelines are provided, center food in the oven.

Traditional Bake

The Bake mode is for baking and roasting. When preparing baked goods such as cakes, cookies, and pastries, always preheat the oven first. To use this mode press the Bake pad, enter a temperature, and then press Start.

Convection Bake

This mode uses air movement from the convection fan to enhance cooking evenness. Your oven is equipped with Auto Recipe Conversion, so it is not necessary to adjust the temperature when using this mode. Always preheat when using this mode. Baking time might be slightly longer for multiple racks than what would be expected for a single rack. To use this mode press the Convection Bake pad, enter a temperature, and then press Start.

Convection Roast

The Convection Roast mode is intended for roasting whole cuts of meat on a single rack. This mode uses air movement from the convection fan to improve browning and reduce

cooking time. Check food earlier than the recipe suggested time when using this mode. To use this mode press the Convection Roast pad. enter a temperature. and then press Start.

Air Fry

Air Fry is a special, no-preheat, cooking mode that is designed to produce foods with a crispier exterior than traditional oven cooking. The Air Fry mode is intended for single rack cooking only. Select Air Fry. then input the desired set temperature and press Start. The temperature can be set between 300°F and 500°F.

Preheating is not recommended for this mode. Follow traditional oven recipe or package guidelines for set temperatures and cook times; adjust cook time to achieve your desired crispness. Additional guidelines for using this mode can be found in the Cooking Guide.

Broiling Modes

Always broil with the oven door closed. Monitor food closer to the broil element increases smoking, spattering, and the possibility of fats igniting. It is not necessary to preheat when using the Broil modes.

Broil Hi

The Broil Hi mode uses intense heat from the upper element to sear foods. Use Broil Hi for thinner cuts of meat and/or when you would like to have a seared surface and rare interior. To use this mode press the Broil pad once and then press Start.

Broil Lo

The Broil Lo mode uses less intense heat from the upper element to cook food thoroughly while also browning foods that you would like cooked all the way through. To use this mode press the Broil pad twice and then press Start.

Warm

Warm modes are designed to keep hot, cooked foods hot. Cover foods that should remain moist and do not cover foods that should be crisp. Preheating is recommended that food not be kept warm for more than 2 hours. To use this mode, press the Warm pad then press Start. The control display will show the oven is set to Bake at 170F.

Oven Cooking Guide

FOOD TYPE	RECOMMENDED MODE(S)	RECOMMENDED RACK POSITION(S)	ADDITIONAL SUGGESTIONS
Baked Goods			
Layer Cakes, sheet cakes, bundt cakes, muffins, quick breads on a Single Rack	Bake	3	Use shiny cookware.
Layer cakes* on Multiple Racks	Bake Convection Bake	2 and 4	Ensure adequate airflow (see illustration below).
Chiffon cakes (angel food)	Bake	1	Use shiny cookware.
Cookies, biscuits, scones on a Single Rack	Bake	3	Use shiny cookware.
Cookies, biscuits, scones on Multiple Racks	Convection Bake	2 and 4 2, 4, and 6	Ensure adequate airflow.
Beef & Pork			
Hamburgers	Broil Hi	6	Use a broil pan; move food down for more doneness/less searing. Watch food closely when broiling. For best performance center food below the broil heating element.
Steaks & Chops	Broil Hi	6	Use a broil pan; move food down for more doneness/less searing. Watch food closely when broiling. For best performance center food below the broil heating element.
Roasts	Bake Convection Roast	2 or 3	Use a low sided pan such as a broil pan. Preheating is not necessary.
Poultry			
Whole chicken	Bake Convection Roast	2 or 3	Use a low sided pan such as a broil pan.
Bone-in chicken breasts, legs, thighs	Broil Hi	2	If breaded or coated in sauce avoid Broil Hi modes. Broil skin side down first. Watch food closely when broiling. For best performance when broiling, center food below the broil heating element.
	Broil Lo Bake	2 or 3	
Boneless chicken breasts	Broil Lo Bake	2 or 3	Move food down for more doneness/less searing and up for greater searing/browning when broiling. For best performance when broiling, center food below the broil heating element
Whole turkey	Bake Convection Roast	1 or 2	Use a low sided pan such as a broil pan.
Turkey Breast	Bake Convection Roast	2 or 3	Use a low sided pan such as a broil pan.
Fish	Broil Lo	6 (1/2 thick or less) 5 (> 1/2 inch)	Watch food closely when broiling. For best performance center food below the broil heating element.
Casseroles	Bake	3	
Frozen Convenience Foods			
Single Rack	Bake	4	Place food in oven prior to starting mode. Use dark cookware for more browning/crisping; use shiny cookware for less browning.
Multiple Racks	Convection Bake	2 and 4	Use dark cookware for more browning/crisping; use shiny cookware for less browning. For multiple racks of pizzas, stagger left to right, do not place directly over each other.

+ When baking four cake layers at a time with traditional bake. use racks 2 and 4.

+ When baking four cake layers at a time with convection bake. use racks 2 and 4.

Cook food thoroughly to help protect against food borne illness. Minimum safe food temperature recommendations for food safety can be found at IsItDoneYet.gov. Make sure to use a food thermometer to take food temperatures.



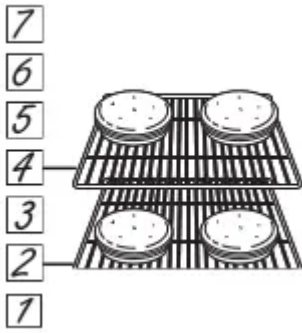

Air Fry Cooking Guide

Air Fry is a special, no-preheat, cooking mode that is designed to produce foods with a crispier exterior than traditional oven cooking. Select Air Fry, then input the desired set temperature and press Start. The temperature can be set between 300°F and 500°F.

Air Fry Cookware Guidelines

- Only use broil safe cookware when using Air Fry mode.
- A dark sheet pan is recommended. A dark pan promotes better browning and crisping.
- Oven baking baskets and baking grids can also be used. A sheet pan should be placed on the rack below the foods to catch any drippings when using a baking basket.

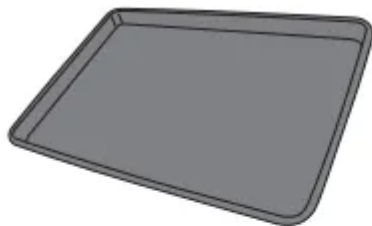

Primary recommended cookware



Alternate cookware options

General Tips for Air Fry Mode

- The Air Fry mode is designed for cooking on a single rack.
- The Air Fry mode is designed to be used without preheating.
- Foods may cook faster than expected if the oven is already hot when food is placed in the oven.
- When air frying foods with sauce, it is recommended to apply the sauce at the end of cooking.
- If foods are browning too quickly, try a lower rack position or lower oven set temperature.

- For packaged foods. use traditional oven cooking instructions for set temperature and expected cook time.
- It is not necessary to flip or stir food during cooking
- Arrange food in a single layer on the pan. do not overload the pan.
- Always check internal food temperature to confirm minimum safe temperatures have been reached. Minimum safe food temperatures can be found on packages and at IsItDoneYet.gov.

FOOD TYPE	RECOMMENDED RACK POSITION(S)	RECOMMENDED SET TEMPERATURES (F°)	RECOMMENDED COOK TIME (MIN)	NOTES
Fresh boneless fish or poultry pieces, breaded such as nuggets, tenders, fillets	4	375-400	15-30	User lower set temperatures for larger pieces. Use shiny cookware.
Fresh bone in chicken wings	4	375-400	25-40	Salt wings or coat in a dry rub, if using sauce apply after cooking or toward the end of cooking
Fresh bone in chicken drumsticks or thighs	3 or 4	375-400	30-55	User lower set temperatures for larger pieces.
Fresh French fries, thin (< 1/2 inch)	4	400-425	15-30	Parchment paper is recommended when preparing fresh French fries. For crispier fries, toss fries in corn starch or rice flour before cooking.
Fresh French fries, thick (> 1/2 inch)	3 or 4	375-400	20-35	Parchment paper is recommended when preparing fresh French fries. For crispier fries, toss fries in corn starch or rice flour before cooking.
Frozen packaged foods	3 or 4 (use rack position 3 for thicker foods)	Use traditional oven(not Air Fry) cooking instructions as a guideline for set temperature and cook time. Additional cook time beyond recommended package time may be required for some foods. If oven is hot when starting, food may cook faster than the minimum package time.		

Cleaning the Range

Be sure all controls are off and all surfaces are cool before cleaning any part of the range.

WARNING If your range is removed for cleaning, servicing or any reason, be sure the anti-tip device is reengaged properly when the range is replaced. Failure to take this precaution could result in tipping of the range and can result in death or serious burns to children or adults.

Control Knobs

The control knobs may be removed for easier cleaning. Make sure the knobs are in the OFF positions and pull them straight off the stems for cleaning. The knobs can be washed with soap and water. Make sure the inside of the knobs are dry before replacing. Replace the knobs, in the OFF position to ensure proper placement.

Control Lockout

If desired, the touch pads may be deactivated before cleaning. See Lock Controls in the Oven Controls section in this manual. Clean up splatters with a damp cloth. You may also use a glass cleaner, abrasives of any kind. Reactivate the touch pads after cleaning.

Control Panel

It's a good idea to wipe the control panel after each use. Clean with mild soap and water or vinegar and water, rinse with clean water and polish dry with a soft cloth.

Do not use abrasive cleansers, strong liquid cleansers, plastic scouring pads or oven cleaners on the control panel—they will damage the finish, including Black Stainless Steel.

Oven Exterior

Do not use oven cleaners, abrasive cleansers, strong liquid cleansers, steel wool, plastic scouring pads, or cleaning powders on the interior or exterior of the oven.

Clean with a mild soap and water or vinegar and water solution. Rinse with clean water and dry with a soft cloth.

When cleaning surfaces, make sure that they are at room temperature and not in direct sunlight.

If stain on the door vent trim is persistent, use a mild abrasive cleaner and a sponge-scrubber for best results. Spillage of marinades, fruit juices, tomato sauces and basting liquids containing acids may cause discoloration and should be wiped up immediately. Let hot surfaces cool, then clean and rinse.

Painted Surfaces, Black Stainless Steel, and Fingerprint Resistant Stainless Steel

Painted surfaces include the sides of the range and the door, top of control panel and the drawer front. Clean these with soap and water or a vinegar and water solution.

Do not use commercial oven cleaners, cleaning powders, steel wool or harsh abrasives on any painted surface, including Black Stainless Steel.

Stainless Steel - Excluding Black Stainless Steel

Do not use a steel wool pad; it will scratch the surface. To clean the stainless steel surface, use warm sudsy water or a stainless steel cleaner or polish. Always wipe the surface in the direction of the grain. Follow the cleaner instructions for cleaning the stainless steel surface. Cleaners with oxalic acid such as Bar Keepers Friend Soft Cleanser will remove surface rust, tarnish and small blemishes. Use only a liquid cleanser free of grit and rub in the direction of the brush lines with a damp, soft sponge.

To inquire about purchasing cleaning products including stainless steel appliance cleaner or polish, see the Accessories and Consumer Support sections at the end of this manual.

Porcelain Enamel Cooktop Frame

The porcelain enamel finish is sturdy but breakable if misused. This finish is acid-resistant. However, any acidic foods spilled (such as fruit juices, tomato or vinegar) should not be permitted to remain on the finish. If acids spill on the cooktop while it is hot, use a dry paper towel or cloth to wipe it up right away. When the surface has cooled, wash with soap and water. Rinse well.

For other spills such as fat splatterings, wash with soap and water or cleansing powders after the surface has cooled. Rinse well. Polish with a dry cloth.

The interior of your new oven can be cleaned manually or by using Steam Clean or Self Clean modes.

Spillage of marinades, fruit juices, tomato sauces and basting liquids containing acids may cause discoloration and should be wiped up immediately. Let hot surfaces cool, then clean and rinse.

Manual Cleaning

Do not use oven cleaners, abrasive cleaners, strong liquid cleansers, steel wool, scouring pads, or cleaning powders on the interior of the oven. Clean with a mild soap and water or vinegar and water solution. Rinse with clean water and dry with a soft cloth. When cleaning surfaces, make sure that they are at room temperature.

Steam Clean Mode

Steam clean is intended to clean small spills using water and a lower cleaning temperature than Self-Clean.

To use the Steam Clean feature, wipe grease and soils from the oven. Pour one cup of water into the bottom of the oven. Close the door.

Press the Steam Clean pad and then press Start. You can not open the door during the 30 minute steam clean as this will decrease the steam clean performance. Wipe out any excess water and any remaining soil.

Self Clean Mode

Read Self-Cleaning Oven Safety Instructions at the beginning of this manual before using Self Clean Mode.

Self clean uses very high temperatures to clean the oven interior. The oven door will lock when using this feature.

Before operating the self-clean cycle, wipe up grease and soils from the oven. Remove all items from the oven other than enameled (dark color) racks. Shiny or silver racks, the meat probe, and any cookware or other items should all be removed from the oven before initiating a self-clean cycle. Close the door.

Press the Self Clean pad and a default self-clean time is displayed. The clean time can be changed to any time between 3:00 and 5:00 hours by using the number pads to enter a different time and pressing Start. For heavily soiled ovens, the maximum 5 hour clean time is recommended. If you wish to use the default time, press the Start pad immediately after pressing the Self Clean pad. The oven will turn off automatically when the self clean cycle is complete. The door will stay locked until the oven has cooled down. After the oven has cooled down wipe any ash out of the oven.

We recommend venting your kitchen with an open window or using a ventilation fan or hood during the first self-clean cycle.

Soil on the front frame of the range and outside the gasket on the door will need to be cleaned by hand.

Clean these areas with hot water, soap-filled steel-wool pads or cleansers such as Soft Scrub. Rinse well with clean water and dry.

Make sure the oven light bulb cover is in place and the oven light is off.

IMPORTANT: The health of some birds is extremely sensitive to the fumes given off during the self-cleaning cycle of any range. Move birds to another well-ventilated room.

Racks

All racks can be washed with warm, soapy water. Enameled (not shiny) racks can be left in the cavity during self clean. Racks may be more difficult to slide, especially after a self-clean. Put some vegetable oil on a soft cloth or paper towel and rub onto the left and right edges.

Oven Heating Elements

Do not clean the broil element. Any soil will burn off when the elements are heated.

The bake element is not exposed and is under the oven floor. Clean the oven floor with warm, soapy water.

Cleaning the Glass Cooktop

To maintain and protect the surface of your glass cooktop, follow these steps:

1. Before using the cooktop for the first time, clean it with a ceramic cooktop cleaner. This helps protect the top and makes cleanup easier.
2. Regular use of ceramic cooktop cleaner will help keep the cooktop looking new.
3. Shake the cleaning cream well. Apply a few drops of ceramic cooktop cleaner directly to the cooktop.
4. Use a paper towel or non-scratch cleaning pad for ceramic cooktops to clean the entire cooktop surface.
5. Use a dry cloth or paper towel to remove all cleaning residue. No need to rinse..

NOTE: It is very important that you **DO NOT** heat the cooktop until it has been cleaned thoroughly.

Burned-On Residue

1. Allow the cooktop to cool.
2. Spread a few drops of ceramic cooktop cleaner on the entire burned residue area.
3. Using a non-scratch cleaning pad for ceramic cooktops, rub the residue area, applying pressure as needed.
4. If any residue remains, repeat the steps listed above as needed.

5. For additional protection, after all residue has been removed, polish the entire surface with ceramic cooktop cleaner and a paper towel.

Heavy, Burned-On Residue

1. Allow the cooktop to cool.
2. Use a single-edge razor blade scraper at approximately a 45° angle against the glass surface and scrape the soil. It will be necessary to apply pressure to the razor scraper in order to remove the residue.
3. After scraping with the razor scraper, spread a few drops of ceramic cooktop cleaner on the entire burned residue remaining residue.
4. For additional protection, after all residue has been removed, polish the entire surface with ceramic cooktop cleaner and a paper towel.

The ceramic cooktop scraper and all recommended supplies are available through our Parts Center. See the Accessories and Consumer Support sections at the end of this manual.

NOTE: Do not use a dull or nicked blade.

Metal Marks and Scratches

1. Be careful not to slide pots and pans across your cooktop. It will leave metal markings on the cooktop surface.

These marks are removable using the ceramic cooktop cleaner with a non-scratch cleaning pad for ceramic cooktops.

2. If pots with a thin overlay of aluminum or copper are allowed to boil dry, the overlay may leave black discoloration on the cooktop.

This should be removed immediately before heating again or the discoloration may be permanent.

NOTE: Carefully check the bottom of pans for roughness that would scratch the cooktop.

Cooktop Seal

To clean the cooktop seal around the edges of the glass, lay a wet cloth on it for a few minutes, then wipe clean with nonabrasive cleaners.

Damage from Sugary Spills and Melted Plastic

Special care should be taken when removing hot substances to avoid permanent damage of the glass surface.

Sugary spillovers (such as jellies, fudge, candy, syrups) or melted plastics can cause pitting of the surface of your cooktop (not covered by the warranty) unless the spill is removed while still hot. Special care should be taken when removing hot substances.

Be sure to use a new, sharp razor scraper.

1. Turn off all surface units. Remove hot pans.
2. Wearing an oven mitt:
 - a. Use a single-edge razor blade scraper to move the spill to a cool area on the cooktop.
 - b. Remove the spill with paper towels.
3. Any remaining spillover should be left until the surface of the cooktop has cooled.
4. Don't use the surface units again until all of the residue has been completely removed.

NOTE: If pitting or indentation in the glass surface has already occurred, the cooktop glass will have to be replaced. In this case, service will be necessary.

Oven Light

WARNING SHOCK OR BURN HAZARD: Before replacing oven light bulb, disconnect the electrical power to the range at the main fuse or circuit breaker panel. Failure to do so may result in electric shock or burn.

CAUTION BURN HAZARD: The glass cover and bulb should be removed when cool. Touching hot glass with bare hands or a damp cloth can cause burns.

Oven Light Replacement

To remove:

1. Turn the glass cover counterclockwise 1/4 turn until the tabs of the glass cover clear the grooves of the socket. Wearing latex gloves may offer a better grip.
2. Remove the bulb by turning it counter-clockwise.

To replace:

1. Replace bulb with a new 40-watt appliance bulb.
Insert the bulb and turn it clockwise until it is tight.
2. Place the tabs of the glass cover into the grooves of the socket. Turn the glass cover clockwise 1/4 turn. For improved lighting inside the oven, clean the glass cover frequently using a wet cloth. This should be done when the oven is completely cool.
3. Reconnect electrical power to the oven.

Oven Door

The door is very heavy. Be careful when removing and lifting the door. Do not lift the door by the handle.

To remove the door:

1. Fully open the door.

2. Pull the hinge locks down toward the door frame. to the unlocked position. A tool, such as a small flat blade screwdriver, may be required.
3. Firmly grasp both sides of the door at the top.
4. Close door to the door removal position. The door should be open approximately 3" with no obstruction above the door.
5. Lift door up and out until both hinge arms are clear of the slots.

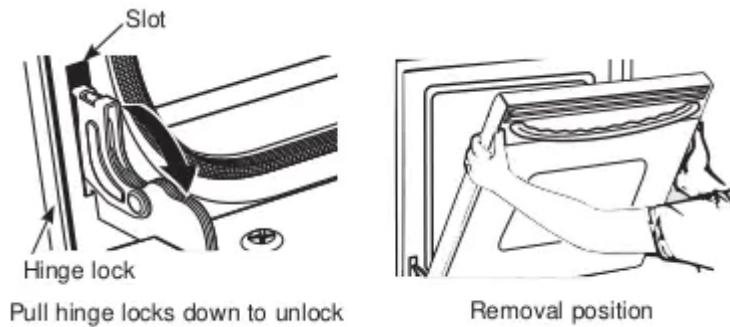

To replace the door:

1. Firmly grasp both sides of the door at the top.
 2. Starting on the left side, with the door at the same angle as the removal position, seat the indentation of the hinge arm into the bottom edge of the hinge slot.
- The notch in the hinge arm must be fully seated into the bottom of the slot. Repeat for right side.
3. Fully open the door. If the door will not fully open, the indentation is not seated correctly in the bottom edge of the slot.
 4. Push the hinge locks up against the front frame of the oven cavity, to the locked position.
 5. Close the oven door.

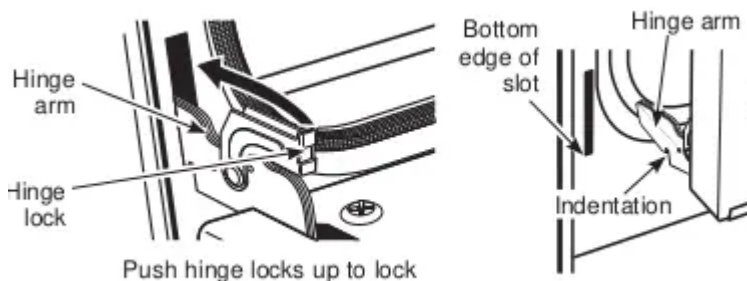

Removable Storage Drawer

To remove the drawer:

1. Pull the drawer out until it stops.
2. Lift the front of the drawer until the stops clear the guides.
3. Remove the drawer.

To replace the drawer:

1. Place the drawer rails on the guides.
2. Push the drawer back until it stops.
3. Lift the front of the drawer and push back until the stops clear the guides.
4. Lower the front of the drawer and push back until it closes.

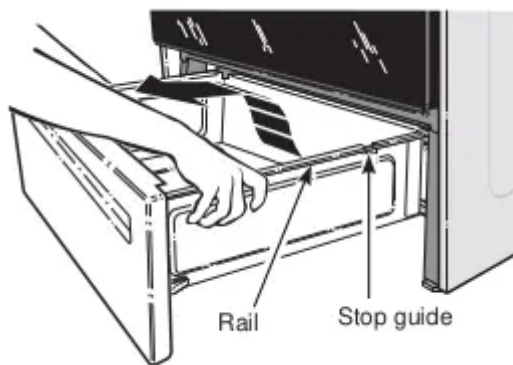

Removable Storage Drawer (on some models)

The storage drawer is a good place to store cookware and bakeware. Do not store plastics or flammable material in the drawer.

The storage drawer may be removed for cleaning under the range. Clean the storage drawer with a damp cloth or sponge. Never use harsh abrasives or scouring pads.

Removing the Storage Drawer (for models that have release tabs):

1. Pull the drawer straight out until it stops.
2. While pulling the drawer forward, press the left rail release lever up and the right rail release lever down.
3. Continue to pull the drawer forward until completely detached from the unit.

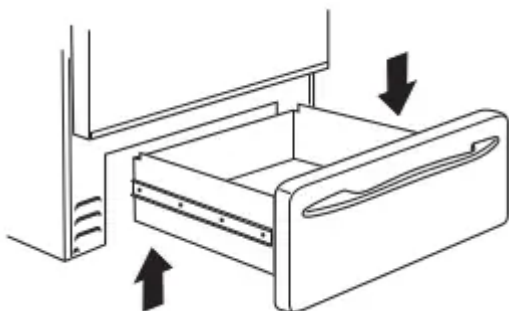

Removing the Storage Drawer (for models that do not have release tabs):

1. Pull drawer straight out until it stops.
2. Continue to pull the drawer until it is detached from the oven.

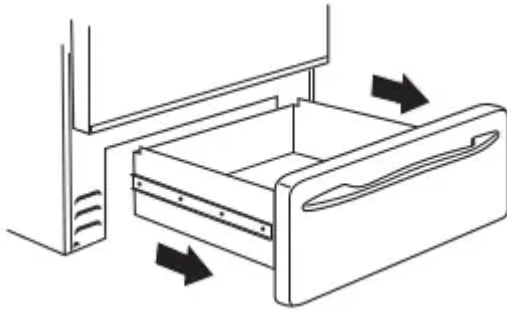

Replacing the Storage Drawer:

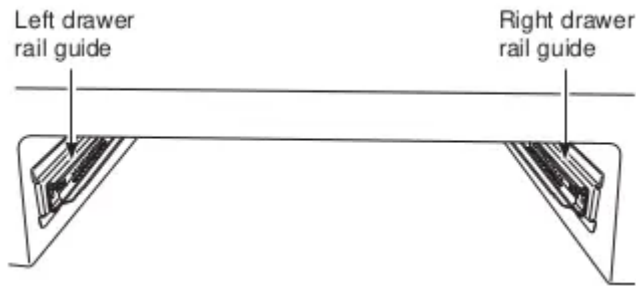

1. Rest the left drawer rail inside the inner left rail guide channel at the bottom and slide it in slightly.

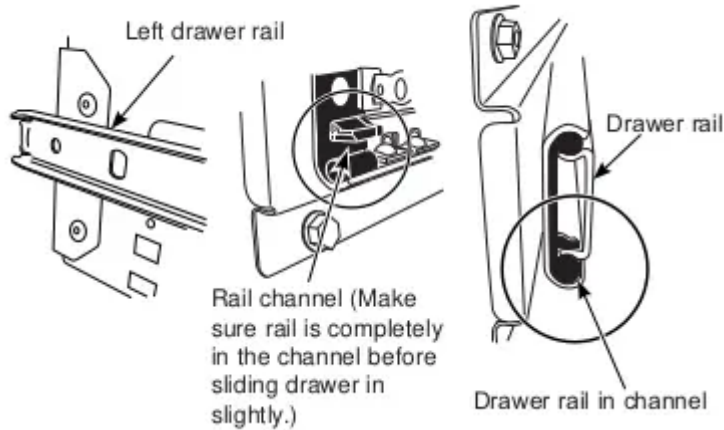

2. Place the right drawer rail inside the inner right rail guide channel at the top and slide it in slightly.



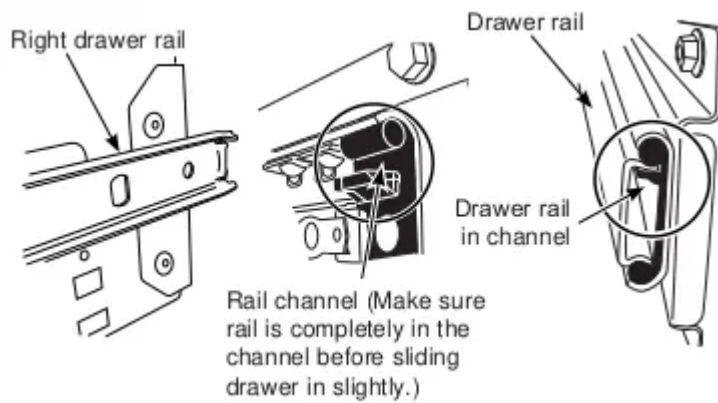

3. Keep the drawer straight (no need to tilt) and slide the drawer all the way in.

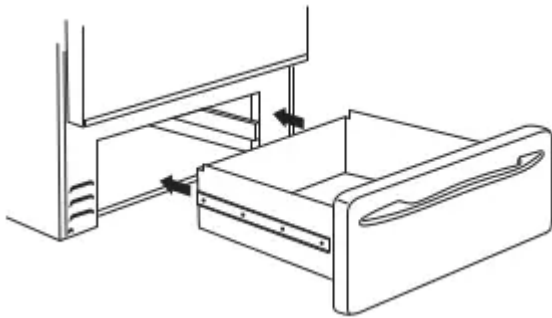

Troubleshooting Tips

Save time and money! Review the charts on the following pages first and you may not need to call for service.

Surface units will not maintain a rolling boil or cooking is not fast enough

Improper cookware being used, surface unit selected.

- Use pans which are flat and match the diameter of the surface unit selected.

In some areas, the power (voltage) may be low.

- Cover pan with a lid until desired heat is obtained.

Surface units do not work properly

A fuse in your home may be blown or the circuit breaker tripped.

- Replace the fuse or reset the circuit breaker.

Cooktop controls improperly set.

- Check to see the correct control is set for the surface unit you are using.

Surface unit stops glowing when turned to a lower setting

The unit is still on and hot.

- This is normal.

Scratches (may appear as cracks) on cooktop glass surface

Incorrect cleaning methods being used.

- Scratches are not removable. Tiny scratches will become less visible in time as a result of cleaning.

Cookware with rough bottoms being used or coarse particles (salt or sand) were between the cookware and the surface of the cooktop. Cookware has been slid across the cooktop surface.

- To avoid scratches, use the recommended cleaning procedures. Make sure bottoms of cookware are clean before use, and use cookware with smooth bottoms.

Areas of discoloration on the cooktop

Food spillovers not cleaned before next use.

- See the Cleaning the glass cooktop section.

Hot surface on a model with a light colored cooktop.

- This is normal. The surface may appear discolored when it is hot. This is temporary and will disappear as the glass cools.

Plastic melted to the surface

Hot cooktop came into contact with plastic placed on the hot cooktop.

- See the Glass surface—potential for permanent damage section in the Cleaning the glass cooktop section.

Pitting (or indentation) of the cooktop

Hot sugar mixture spilled on the cooktop.

- Call a qualified technician for replacement.

Frequent cycling off and on of surface units

Improper cookware being used.

- Use only flat cookware to minimize cycling.

My new oven doesn't cook like my old one. Is something wrong with the temperature settings?

Your new oven has a different cooking system from your old oven and therefore may cook differently than your old oven.

- For the first few uses, follow your recipe times and temperatures carefully. If you still think your new oven is too hot or too cold, you can adjust the temperature yourself to meet your specific cooking preference. See the Special Features section. NOTE: This adjustment

affects Bake. and Convection Bake temperatures; it will not affect Convection Roast. Broil or Clean.

Food does not bake properly

Oven controls improperly set.

- See the Cooking Modes section.

Rack position is incorrect or rack is not level.

- See the Cooking Modes section and Cooking Guide.

Incorrect cookware or cookware of improper size being used.

- See the Cookware section.

Oven temperature needs adjustment.

- See the Special Features section.

Ingredient substitution

- Substituting ingredients can change the recipe outcome.

Food does not broil properly

Oven controls improperly set.

- Make sure you select the appropriate broil mode.

Improper rack position being used.

- See Cooking Guide for rack location suggestions.

Food being cooked in a hot pan.

- Make sure cookware is cool.

Cookware not suited for broiling.

- Use a pan specifically designed for broiling.

Aluminum foil used on the broiling pan and grid has not been fitted properly and slit as recommended.

- If using aluminum foil conform to pan slits.

In some areas the power (voltage) may be low.

- Preheat the broil element for 10 minutes.

Oven temperature too hot or too cold

Oven temperature needs adjustment.

- See the Special Features section.

Oven does not work or appears not to work

A fuse in your home may be blown or the circuit breaker tripped.

- Replace the fuse or reset the circuit breaker.

Oven controls improperly set.

- See the Using the Oven section.

Oven is in Sabbath Mode.

- Verify that the oven is not in Sabbath Mode. See the Special Features section.

“Crackling” or “popping” sound

This is the sound of the metal heating and cooling during both the cooking and cleaning functions.

- This is normal.

Why is my range making a "clicking" noise when using my oven?

Your range cycles the heating elements by turning relays on and off to maintain the oven temperature.

- This is normal.

Clock and timer do not work

A fuse in your home may be blown or the circuit breaker tripped.

- Replace the fuse or reset the circuit breaker.

Plug on range is not completely inserted in the electrical outlet.

- Make sure electrical plug is plugged into a live, properly grounded outlet.

Oven controls improperly set.

- See the Oven controls section.

Storage drawer won't close

Power cord may be obstructing drawer in the lower back of the range.

- Reposition the drawer and power cord. See the Storage the range section.

Rear drawer support is on top of the guide rail.

- Reposition the drawer. See the Storage Drawer Removal instructions in the Care and cleaning of the range section.

The soft close mechanism may be uncoupled from the drawer.

- Reset the mechanism - see Soft Close Drawer section.

Oven door is crooked

The door is out of position.

- Because the oven door is removable, it sometimes gets out of position during installation. To straighten the instructions in the "Care and Cleaning" section.

Oven will not work remotely

Router issues, no wireless signal, etc.

- For assistance with oven wireless network connectivity, please call 1.800.220.6899.

Oven is not connected.

- For assistance with oven wireless network connectivity, please call 1.800.220.6899.

Oven light does not work

Light bulb is loose or defective.

- Tighten or replace bulb.

Pad operating light is broken.

- Call for service.

Oven will not self-clean

The temperature is too high to set a self-clean operation.

- Allow the oven to cool and reset the controls.

Oven controls improperly set.

- See the Cleaning the Oven section.

Excessive smoking during clean cycle

Excessive soil or grease.

- Press the Cancel/Off pad. Open the windows to rid the room of smoke. Wait until the LOCKED light goes off. Wipe up the excess soil and reset the clean cycle.

Excessive smoking during broiling

Food too close to burner element.

- Lower the rack position of the food.

Oven door will not open after a clean cycle

Oven too hot.

- Allow the oven to cool below locking temperature.

Oven not clean after a clean cycle

Oven controls improperly set.

- See the Cleaning the Oven section.

Oven was heavily soiled.

- Clean up heavy spillovers before starting the clean cycle. Heavily soiled ovens may need to self-clean again or for a longer period of time.

DOOR LOCK flashes in the display

The self-clean cycle has been selected but the door is not closed.

- Close the oven door.

DOOR LOCK light is on when you want to cook

The oven door is locked because the temperature inside the oven has not dropped below the locking temperature.

- Press the Cancel/Off pad. Allow the oven to cool.

“F- and a number or letter” flash in the display

You have a function error code.

- Press the Cancel/Off pad. Allow the oven to cool for one hour. Put the oven back into operation.

If the function code repeats.

- Disconnect all power to the oven for at least 30 seconds and then reconnect power. If the function error code repeats. call for service.

Display goes blank

A fuse in your home may be blown or the circuit breaker tripped.

- Replace the fuse or reset the circuit breaker.

The clock is turned off.

- See the Special features section.

Oven is in Sabbath Mode.

- Verify that the oven is not in Sabbath Mode. See the Special Features section.

Power outage. clock flashes

Power outage or surge

- Reset the clock. If the oven was in use. you must reset it by pressing the Cancel/Off pad. setting the clock and resetting any cooking function.

“Burning” or “oily” odor emitting from the vent

This is normal in a new oven and will disappear in time.

- To speed the process. set a self-clean cycle for a minimum of 3 hours. See the Cleaning the Oven section.

Strong odor

An odor from the insulation around the inside of the oven is normal for the first few times the oven is used.

- This is temporary and will go away after several uses or a self-clean cycle.

Fan noise (on some models)

A convection fan may automatically turn on and off.

- This is normal. The fan is designed to operate intermittently to maximize cooking evenness. The convection fan will operate during preheat of the bake cycle. The fan will turn off after the oven is heated to the set temperature. This is normal.

A cooling fan may automatically turn on and off.

- This is normal on some models. The cooling fan will turn off and on to cool internal parts. It may run after the oven is turned off.

My oven door glass appears to be "tinted" or have a "rainbow" color. Is this defective?

No. The inner oven glass is coated with a heat barrier to reflect the heat back into the oven to prevent heat loss and keep the outer door cool while baking.

- This is normal. Under certain light or angles, you may see this tint or rainbow color.

Sometimes the oven takes longer to preheat to the same temperature

Cookware or food in oven.

- The cookware or food in the oven will cause the oven to take longer to preheat. Remove items to reduce preheat time.

Number of racks in oven.

- Adding more racks to the oven will cause the oven to take longer to preheat. Remove some racks.

Different cooking modes

- The different cooking modes use different preheat methods to heat the oven for the specific cooking mode. Some modes will take longer than others (i.e. convection bake).

Display flashes

Power failure.

- Reset the clock.

Unable to get the display to show "OFFSET"

Oven control pads were not touched properly.

- The BROIL HI/LO and BAKE pads must be touched at the same time and held for 3 seconds.

Control signals after entering cooking time or start time

You forgot to enter a bake temperature or cleaning time.

- Touch the BAKE pad and desired temperature or the SELF CLEAN pad and desired clean time.

Oven racks are difficult to slide

The shiny, silver-colored racks were cleaned in a self-clean cycle.

- Apply a small amount of vegetable oil to a paper towel and spray with Pam or other lubricant sprays.

Drawer does not slide smoothly or drags

The drawer is out of alignment.

- Fully extend the drawer and push it all the way in See the Care and cleaning of the range section.

Steam from the vent

When using the ovens, it is normal to see steam coming out of the oven vents. As the number of racks or amount of food being cooked increases, the amount of visible steam will increase.

- This is normal.

Water remaining on oven floor after Steam Clean cycle

This is normal.

- Remove any remaining water with a dry cloth or sponge.

Oven will not steam clean

Display flashes HOT.

- Allow the oven to cool to room temperature and reset the controls.

Oven controls improperly set.

- See the Using Steam Clean section.

Oven door is not closed.

- Make sure you close the door to start steam clean cycle.

Oven will not work remotely (on some models)

Router issues, no wireless signal, etc.

- For assistance with oven wireless network connectivity, please call 1-800-220-6899.

Oven is not connected.

- Remote enable is off Turn remote enable on (see Special Features section of this manual)

Warning

This content is compiled from multiple sources and is provided for reference purposes only. It may not be complete or fully applicable to all situations. If you are unable to resolve your issue, please contact the product manufacturer or an authorized service provider for official support.

Document generated by [ManualsFile](#)