

RANGE MAINTENANCE AND CARE

Clean Cycle



AquaLift® Technology is an innovative cleaning solution that utilizes heat and water to release baked-on spills from the oven in less than 1 hour. This new cleaning technology is a low-heat, odor-free alternative to traditional self-cleaning options.

Allow the oven to cool to room temperature before using the Clean cycle. If your oven cavity is above 200°F (93°C), it will appear in the display, and the Clean cycle will not be activated until the oven cavity cools down

To Clean:

1. Remove all racks and accessories from the oven cavity, and wipe excess soil. Use a plastic scraper to remove easily removed soils

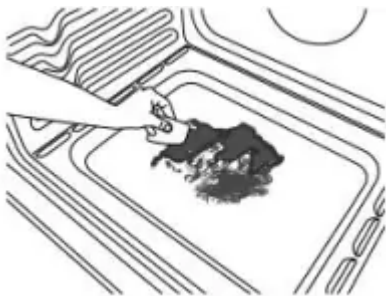

2. Pour distilled or filtered water onto the bottom of the empty oven, and close the oven door.

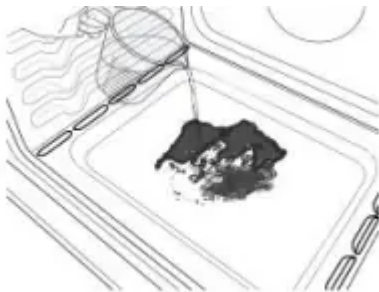

IMPORTANT: Do not use chemicals or other additives with the water. Do not open the oven door during the Clean cycle. The water on the oven bottom is hot.

3. Press CLEAN or AQUALIFT SELF CLEAN and then START on the oven control panel.

4. Allow 40 minutes for cleaning and cool down. A beep will sound when the Clean cycle is complete.
5. Press CANCEL, CANCEL UPPER or OFF at the end of the cycle. Cancel, Cancel Upper or Off may be pressed at any time to stop the Clean cycle.
6. Remove the residual water and loosened soils with a sponge or cloth immediately after the Clean cycle is complete. Much of the initial 2 cups (16 oz [500 mL]) of water will remain in the oven after the cycle is completed. If additional soils remain, leave a small amount of water in the oven bottom to assist with the cleaning.

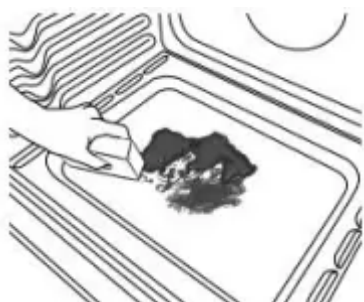

7. If any soils remain, remove them with a non-scratch scrubbing sponge or plastic scraper. Additional Clean cycles may be run to help remove the stubborn soils.

IMPORTANT: Do not use oven cleaners. The use of chemicals, including commercial oven cleaners or metal scouring pads, may cause permanent damage to the porcelain surface of the oven interior.

NOTES:

- The range should be level to ensure that the entire surface of the bottom of the oven cavity is covered by water at the beginning of the Clean cycle.
- For best results, use distilled or filtered water. Tap water may leave mineral deposits on the oven bottom.
- Before removing the residual water and loosened soils at the end of the Clean cycle, insert a cloth or paper towel between the lower edge of the oven door and the front frame to keep water from spilling onto the front of the range and the floor.
- Soil baked on through several cooking cycles will be more difficult to remove with the Clean cycle.
- Nonabrasive scrub sponges or eraser style cleaning pads (without cleaners) can be effective for cleaning the oven cavity walls, oven door and oven bottom for difficult soils. For best results, moisten the pads and sponges before use
- Run an additional Clean cycle for stubborn soils.
- Affresh® Kitchen Appliance Cleaner and affresh® Cooktop Cleaner may be used to clean the oven bottom, walls, and door when the oven has finished the cycle and returned to room temperature. If affresh® Cooktop Cleaner is used, it is recommended to

wipe out the cavity with distilled water as well. Refer to the Quick Start Guide for ordering information.

- Additional AquaLift® Technology Cleaning Kits may be obtained by ordering Part Number W10423113RP. Refer to the Quick Start Guide for ordering information.

General Cleaning

EXTERIOR PORCELAIN ENAMEL SURFACES (on some models)

Food spills containing acids, such as vinegar and tomato, should be cleaned as soon as the entire range is cool. These spills may affect the finish.

Cleaning Method:

- Glass cleaner, mild liquid cleaner, or nonabrasive scrubbing pad: Gently clean around the model/serial/rating plate because scrubbing may remove numbers.
- Affresh® Kitchen and Appliance Cleaner Part Number W10355010 (not included):

See the Quick Start Guide for contact information.

STAINLESS STEEL (on some models)

NOTE: To avoid damage to stainless steel surfaces, do not use soap-filled scouring pads, abrasive cleaners, Cooktop Cleaner, steel-wool pads, gritty washcloths, or abrasive paper towels. Damage may occur to stainless steel surfaces, even with one-time or limited use.

Cleaning Method:

Rub in direction of grain to avoid damaging.

- Affresh® Stainless Steel Cleaner Part Number W10355016 (not included):

See the Quick Start Guide for contact information.

METALLIC PAINT (on some models)

Do not use abrasive cleaners, cleaners with bleach, rust removers, ammonia, or sodium hydroxide (lye) because paint surface may stain

CERAMIC GLASS COOKTOP CLEANING Cleaning Method:

To avoid damaging the cooktop, do not use steel wool, abrasive powder cleansers, chlorine bleach, rust remover, or ammonia

1. Remove food/residue with the Cooktop Scraper.



- For best results, use the Cooktop Scraper while the cooktop is still warm but not hot to the touch. It is recommended to wear an oven mitt while scraping the warm cooktop.
- Hold the Cooktop Scraper at approximately a 45° angle against the glass surface and scrape the residue. It will be necessary to apply pressure in order to remove the residue

Allow the cooktop to cool down completely before proceeding to Step 2.

2. Apply a few dime-sized drops of Cooktop Cleaner to the affected areas.

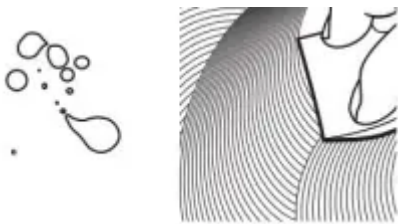

- Rub affresh® Cleaner onto the cooktop surface with the blue Cooktop Cleaning Pad. Some pressure is needed to remove stubborn stains.
- Allow the cleaner to dry to a white haze before proceeding to Step 3

3. Polish with a clean, dry cloth or a clean, dry paper towel.



- Repeat steps 1 through 3 as necessary for stubborn or burned-on stains

The Complete Cooktop Cleaner Kit is available for order including the following:

- Cooktop Scraper
- Affresh® Cooktop Cleaner
- Blue Cooktop Cleaning Pads

COOKTOP CONTROLS

To avoid damage to the cooktop controls, do not use steel wool, abrasive cleansers, or oven cleaner

To avoid damage, do not soak knobs. When replacing knobs, make sure knobs are in the Off position.

On some models, do not remove seals under knobs.

Cleaning Method:

- Soap and water: Pull knobs straight away from control panel to remove

CONTROL PANEL AND OVEN DOOR EXTERIOR

To avoid damage to the control panel, do not use abrasive cleaners, steel-wool pads, gritty washcloths, or abrasive paper towels.

Cleaning Method:

- Glass cleaner and soft cloth or sponge: Apply glass cleaner to soft cloth or sponge, not directly on panel.
- Affresh® Kitchen and Appliance Cleaner Part Number W10355010 (not included):

OVEN RACKS

Cleaning Method:

- Steel-wool pad
- For racks that have discolored and are harder to slide, a light coating of vegetable oil applied to the rack guides will help them slide
- Dishwasher (steam rack water reservoir only, not racks): Although the water reservoir is durable, it may lose its shine and/or discolor when washed in a dishwasher

STORAGE DRAWER OR WARMING DRAWER (on some models)

Check that storage drawer or warming drawer is cool and empty before cleaning

Cleaning Method:

- Mild detergent

BAKING DRAWER (on some models)

Check that baking drawer is cool and empty before cleaning.

Food spills should be cleaned when oven cools. At high temperatures, foods react with porcelain. Staining, etching, pitting, or faint white spots can result.

Cleaning Method:

- Mild detergent

OVEN CAVITY

Depending on your model, use AquaLift® Technology or SelfClean cycle regularly to clean oven spills.

Do not use oven cleaners



Food spills should be cleaned when oven cools. At high temperatures, foods react with porcelain. Staining, etching, pitting, or faint white spots can result.

Cleaning Method:

- Clean cycle: See “Clean Cycle” first.

INSTALLATION INSTRUCTIONS

Unpack Range

1. Remove shipping materials, tape and film from the range. Keep cardboard bottom under range. Do not dispose of anything until the installation is complete.
2. Remove oven racks and parts package from oven and shipping materials.
3. To remove cardboard bottom, first take 4 cardboard corners from the carton. Stack 1 cardboard corner on top of another. Repeat with the other 2 corners. Place them lengthwise on the floor behind the range to support the range when it is laid on its back.
4. Using 2 or more people, firmly grasp the range and gently lay it on its back on the cardboard corners.
5. Remove cardboard bottom

The leveling legs can be adjusted while the range is on its back. See the “Adjust Leveling Legs” section.

NOTE: To place range back up into a standing position, put a sheet of cardboard or hardboard on the floor in front of range to protect the flooring. Using 2 or more people, stand range back up onto the cardboard or hardboard.

Install Anti-Tip Bracket

1. Remove the anti-tip bracket from the inside of the oven.
2. Determine which mounting method to use: floor or wall. If you have a stone or masonry floor, you can use the wall mounting method. If you are installing the range in a mobile home, you must secure the range to the floor. This anti-tip bracket and screws can be used with wood or metal studs.
3. Determine and mark centerline of the cutout space. The mounting bracket can be installed on either the left-hand or right-hand side of the cutout. Position mounting bracket against the wall in the cutout so that the V-notch of the bracket is 12 1/2" (31.8 cm) from centerline, as shown

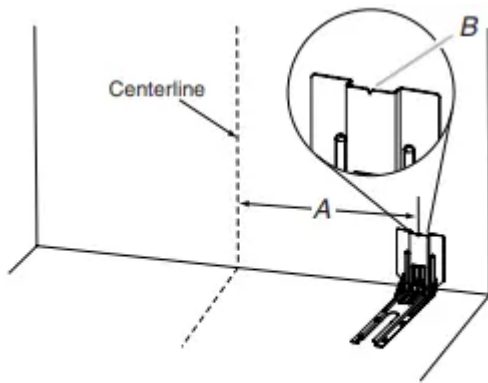

A. 12 1/2" (31.8 cm)
B. Bracket V-notch

4. Drill two 1/8" (3 mm) holes that correspond to the bracket holes of the determined mounting method. See the following illustrations

Floor Mounting

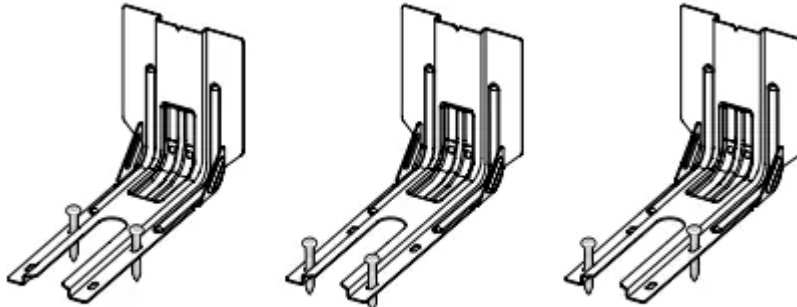

Rear position

Front position

Diagonal (2 options)

Wall Mounting

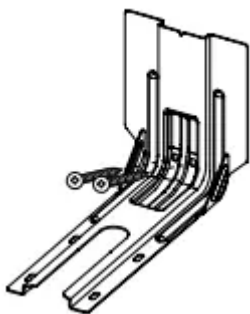

5. Using the two (41 mm) Phillips-head screws provided, mount anti-tip bracket to the wall or floor.

6. Move range close enough to opening to allow for final electrical connections. Remove shipping base, cardboard or hardboard from under range.

7. Move range into its final location, making sure rear leveling leg slides into anti-tip bracket.

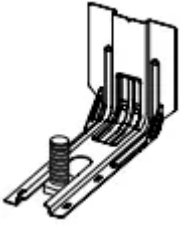

8. Move range forward onto shipping base, cardboard, or hardboard to continue installing the range, using the following installation instructions.

Adjust Leveling Legs

1. If range height adjustment is necessary, use a wrench or pliers to loosen the four leveling legs. This may be done with the range on its back or with the range supported on two legs after the range has been placed back to a standing position.

NOTE: To place range back up into a standing position, put a sheet of cardboard or hardboard in front of range. Using two or more people, stand range back up onto the cardboard or hardboard.

2. Measure the distance from the top of the counter to the floor.

3. Measure the distance from the top of the cooktop to the bottom of the leveling legs. This distance should be the same. If it is not, adjust the leveling legs to the correct height. The leveling legs can be loosened to add up to a maximum of 1" (2.5 cm). A minimum of 3/16" (5 mm) is needed to engage the anti-tip bracket.

NOTE: If height adjustment is made when range is standing, tilt the range back to adjust the front legs, and then tilt forward to adjust the rear legs.

4. When the range is at the correct height, check that there is adequate clearance under the range for the anti-tip bracket. Before sliding range into its final location, check that the anti-tip bracket will slide under the range and onto the rear leveling leg prior to anti-tip bracket installation.

NOTE: If a Trim Kit will be used, the top of the cooktop should be higher than the counter. See the Installation Instructions included with the Trim Kit for the correct height.

Level Range

1. Place level on the oven bottom, as indicated in one of the 2 figures below, depending on the size of the level. Check with the level side to side and front to back.

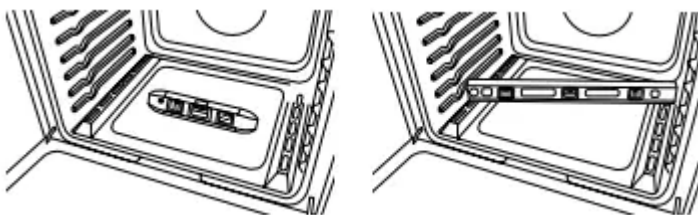

2. If range is not level, use a wrench or pliers to adjust leveling legs up or down until the range is level.

NOTE: Range must be level for satisfactory baking performance and best cleaning results using AquaLift® Self-Clean Technology

Electrical Connection - U.S.A. Only

If your home has a 3- or 4-wire receptacle, continue with “Install Using a Power Supply Cord.” If your home has a 3- or 4-wire direct connection, go to “Install Using Direct Wire.”

Install Using a Power Supply Cord

Power Supply Cord Strain Relief

1. Disconnect power.
2. Remove the lower access cover screws located on the back of the range. Pull the bottom of the cover toward you and out to remove cover from range.

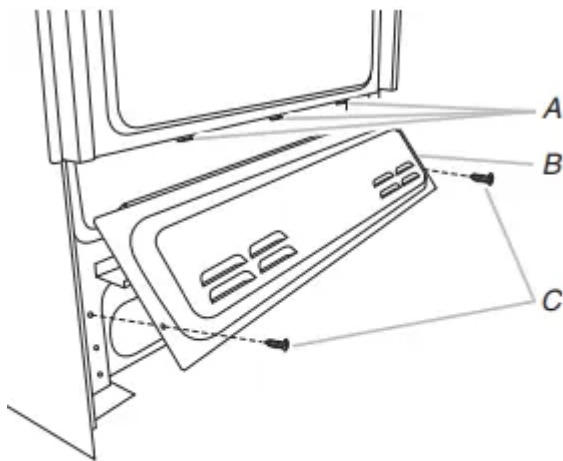

- A. Mounting tabs (3)
- B. Lower access cover
- C. Screws (2)

3. Depending on your model, remove plastic tag holding three 10-32 hex nuts from the middle post of the terminal block. Remove the top 10-32 hex nut from each of the 3 terminal blocks and set aside.

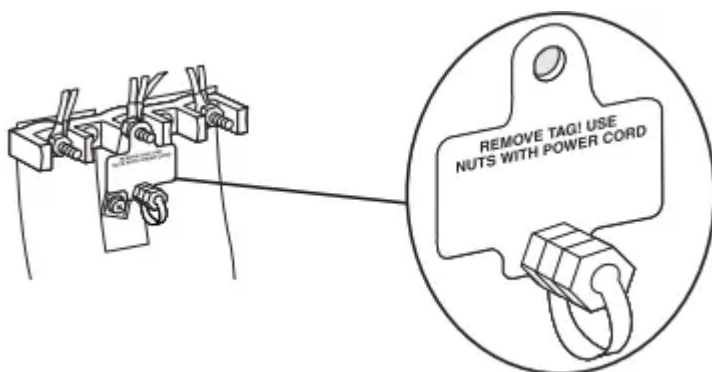

OR

Remove the top 10-32 hex nut from each of the 3 terminal blocks and set aside.

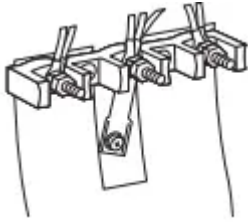

4. Assemble a UL Listed strain relief in the opening.

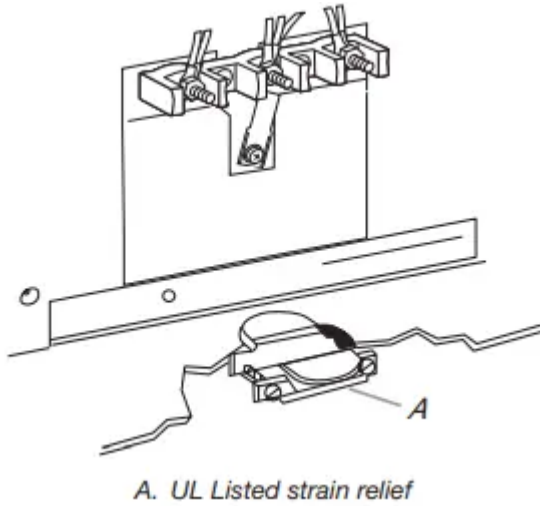



A. UL Listed strain relief

5. Complete installation following instructions for your type of electrical connection:

4-wire (recommended)

3-wire (if 4-wire is not available)

Electrical Connection Options

If your home has:	And you will be connecting to:	Go to section:
3-wire receptacle (NEMA type 10-50R) 	A UL Listed, 250-volt minimum, 40- or 50-amp, range power supply cord	3-Wire Connection: Power Supply Cord
4-wire receptacle (NEMA type 14-50R) 	A UL Listed, 250-volt minimum, 40- or 50-amp, range power supply cord	4-Wire Connection: Power Supply Cord

3-Wire Connection: Power Supply Cord



Use this method only if local codes permit connecting chassis ground conductor to neutral wire of power supply cord.

1. Feed the power supply cord through the strain relief on the cord/conduit plate on bottom of range. Allow enough slack to easily attach the wiring to the terminal block.

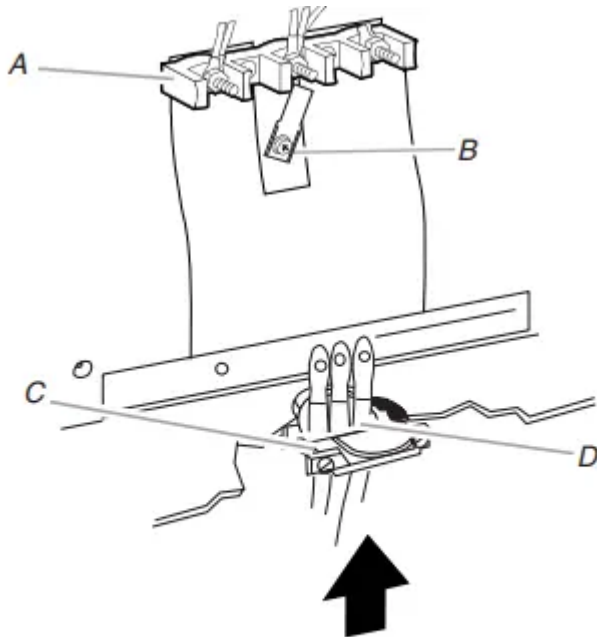

- A. Terminal block
- B. Ground-link screw
- C. UL Listed strain relief
- D. Power supply cord wires - large opening

2. Use a 3/8" (9.5 mm) nut driver to connect the neutral (white) wire to the center terminal block post with one of the 10-32 hex nuts.

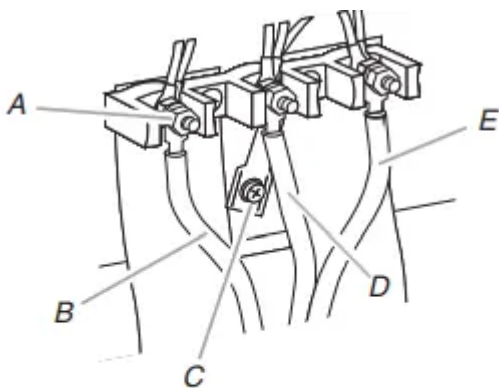

- A. 10-32 hex nut
- B. Line 2 (red) wire
- C. Ground-link screw
- D. Neutral (white) wire
- E. Line 1 (black) wire

3. Connect line 2 (red) and line 1 (black) wires to the outer terminal block posts with 10-32 hex nuts.

4. Firmly tighten hex nuts.

NOTE: For power supply cord replacement, use only a power cord rated at 250 volts minimum, 40- or 50-amps that is marked for use with nominal 13 /8" (3.5 cm) diameter connection opening, with ring terminals and marked for use with ranges.

5. Tighten strain relief screws.

IMPORTANT: Verify the tightness of the hex nuts.

6. Replace lower access cover

4-Wire Connection: Power Supply Cord

Use this method for:

- New branch-circuit installations (1996 NEC)
- Mobile homes
- Recreational vehicles
- In an area where local codes prohibit grounding through the neutral

1. Cut out and remove part of metal ground strap, as shown

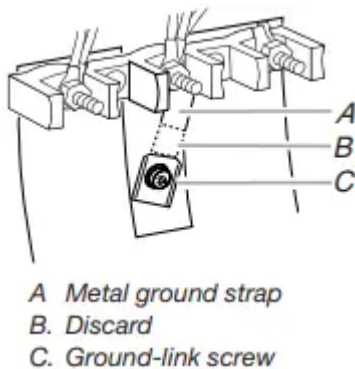

2. Use a Phillips screwdriver to remove the ground-link screw from the back of the range. Save the ground-link screw and the end of the ground link under the screw.

3. Feed the power supply cord through the strain relief on the cord/conduit plate on bottom of range. Allow enough slack to easily attach the wiring to the terminal block

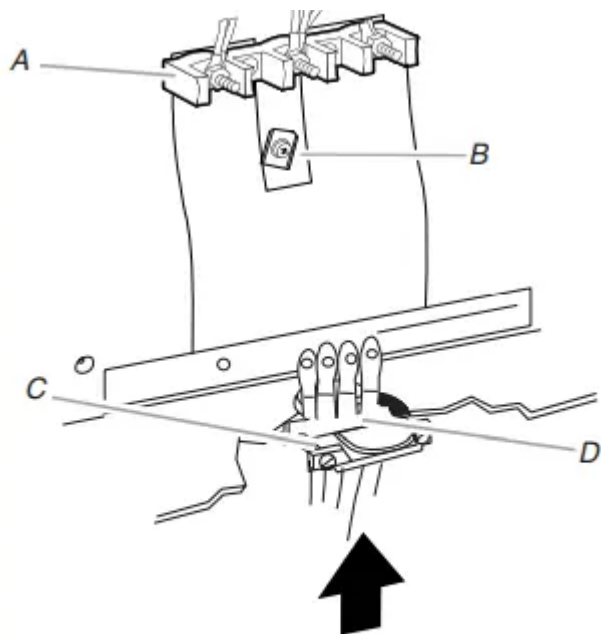

A. Terminal block
 B. Ground-link screw
 C. UL Listed strain relief
 D. Power supply cord wires

4. Use a Phillips screwdriver to connect the green ground wire from the power supply cord to the range with the groundlink screw and ground-link section. The ground wire must be attached over the ground-link section.

5. Use 3/8" (9.5 mm) nut driver to connect the neutral (white) wire to the center terminal block post with one of the 10-32 hex nuts.

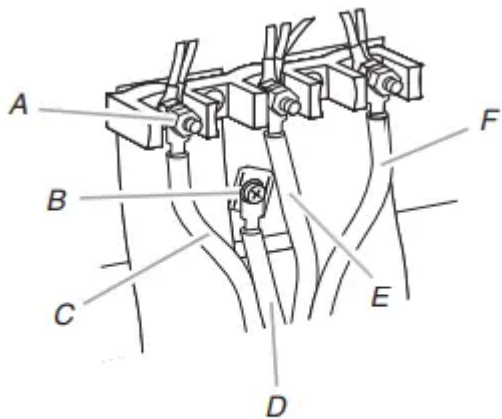

A. 10-32 hex nut
 B. Ground-link screw
 C. Line 2 (red) wire
 D. Green ground wire
 E. Neutral (white) wire
 F. Line 1 (black) wire

6. Connect line 2 (red) and line 1 (black) wires to the outer terminal block posts with 10-32 hex nuts.

7. Firmly tighten hex nuts.

NOTE: For power supply cord replacement, use only a power cord rated at 250 volts minimum, 40- or 50-amps, that is marked for use with nominal 13 /8" (3.5 cm) diameter connection opening, with ring terminals and marked for use with ranges.

8. Tighten strain relief screws.

IMPORTANT: Verify the tightness of the hex nuts.

9. Replace lower access cover

Install Using Direct Wire

Direct Wire Strain Relief

1. Disconnect power.

2. Remove the lower access cover screws located on the back of the range. Pull the bottom of the cover toward you and out to remove cover from range.

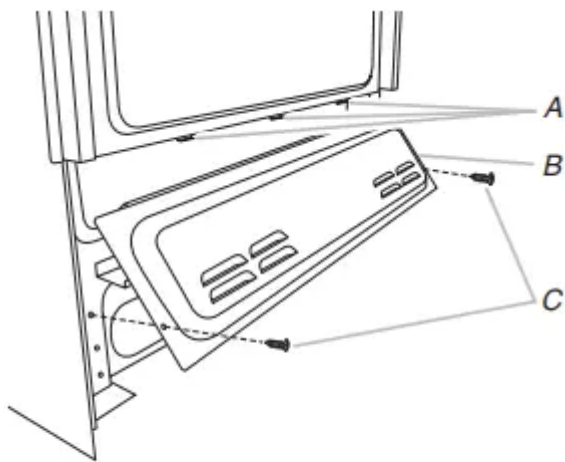

A. Mounting tabs (3)
B. Lower access cover
C. Screws (2)

3. Depending on your model, remove plastic tag holding three 10-32 hex nuts from the middle post of the terminal block. Remove the top 10-32 hex nut from each of the 3 terminal blocks and set aside.

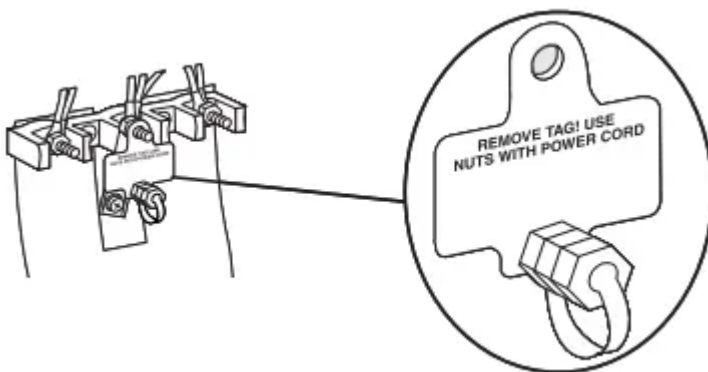

OR

Remove the top 10-32 hex nut from each of the 3 terminal blocks and set aside

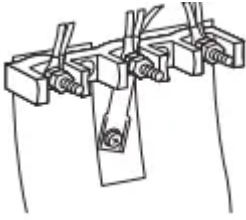

4. Assemble a UL Listed conduit connector in the opening.

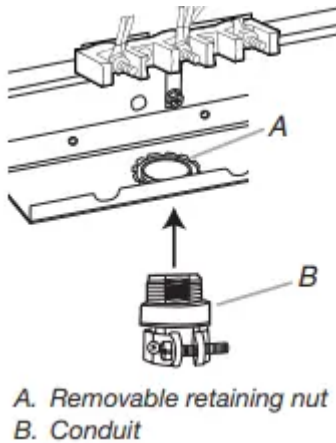

5. Tighten strain relief screw against the flexible conduit



Direct Wire Installation: Copper or Aluminum Wire

This range may be connected directly to the fuse disconnect or circuit breaker box. Depending on your electrical supply, make the required 3-wire or 4-wire connection.

1. Strip outer covering back 3" (7.6 cm) to expose wires. Strip the insulation back 3/8" (1.0 cm) from the end of each wire.

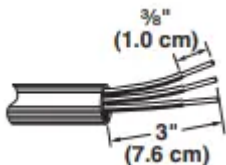

2. Allow enough slack in the wire to easily attach the wiring terminal block.

3. Complete installation following instructions for your type of electrical connection:

4-wire (recommended)

3-wire (if 4-wire is not available)

Electrical Connection Options

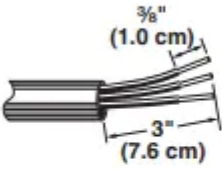
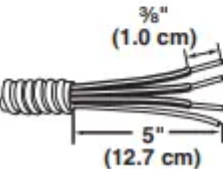
If your home has:	And you will be connecting to:	Go to section:
3-wire direct 	A circuit breaker box or fused disconnect	3-Wire Connection: Direct Wire
4-wire direct 	A circuit breaker box or fused disconnect	4-Wire Connection: Direct Wire

3-Wire Connection: Direct Wire

Use this method only if local codes permit connecting ground conductor to neutral supply wire.

1. Pull the wires through the conduit on cord/conduit plate on bottom of range. Allow enough slack to easily attach the wiring to the terminal block.

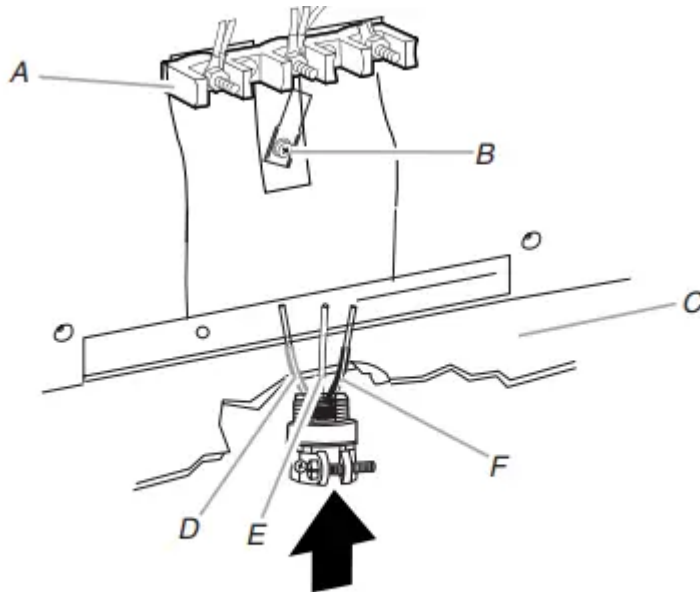

- | | |
|-----------------------|-----------------------------|
| A. Terminal block | D. Line 2 (red) wire |
| B. Ground-link screw | E. Bare (green) ground wire |
| C. Cord/conduit plate | F. Line 1 (black) wire |

2. Attach terminal lugs to line 2 (red), bare (green) ground, and line 1 (black) wires. Loosen (do not remove) the setscrew on the front of the terminal lug and insert exposed wire end through bottom of terminal lugs. Securely tighten setscrew to torque as shown in the following Bare Wire Torque Specifications chart.

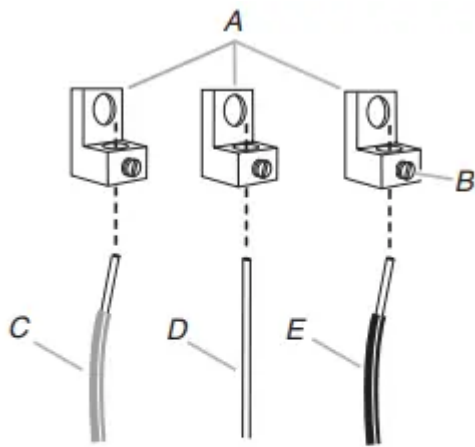

- A. Terminal lug
- B. Setscrew
- C. Line 2 (red) wire
- D. Bare (green) ground wire
- E. Line 1 (black) wire

Bare Wire Torque Specifications

Attaching terminal lugs to the terminal block - 20 lbs-in. (2.3 N-m)

Wire Awg	Torque
8 gauge copper	25 lbs-in. (2.8 N-m)
6 gauge aluminum	35 lbs-in. (4.0 N-m)

3. Use 3/8" (9.5 mm) nut driver to connect the bare (green) ground wire to the center terminal block post with one of the 10-32 hex nuts.

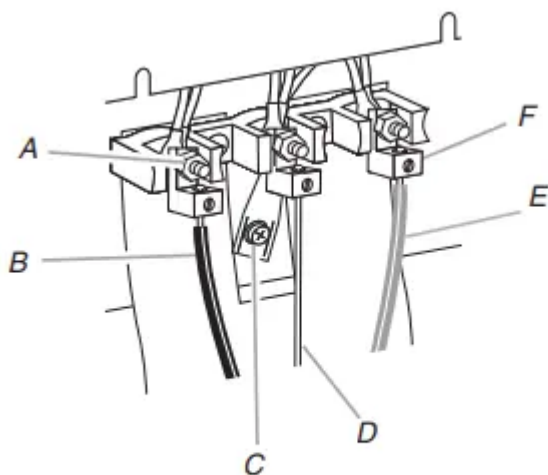

- A. 10-32 hex nut
- B. Line 2 (red) wire
- C. Ground-link screw
- D. Bare (green) ground wire
- E. Line 1 (black) wire
- F. Terminal lug

4. Connect line 2 (red) and line 1 (black) wires to the outer terminal block posts with 10-32 hex nuts.

5. Firmly tighten hex nuts.

IMPORTANT: Verify the tightness of the hex nuts.

6. Replace lower access cover.

4-Wire Connection: Direct Wire

Use this method for:

- New branch-circuit installations (1996 NEC)
- Mobile homes
- Recreational vehicles
- In an area where local codes prohibit grounding through the neutral

1. Cut out and remove part of metal ground strap, as shown.

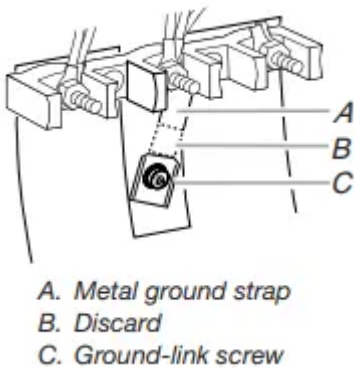

2. Use a Phillips screwdriver to remove the ground-link screw from the back of the range. Save the ground-link screw and the end of the ground link under the screw.

3. Pull the wires through the strain relief on bottom of range. Allow enough slack to easily attach wiring to the terminal block.

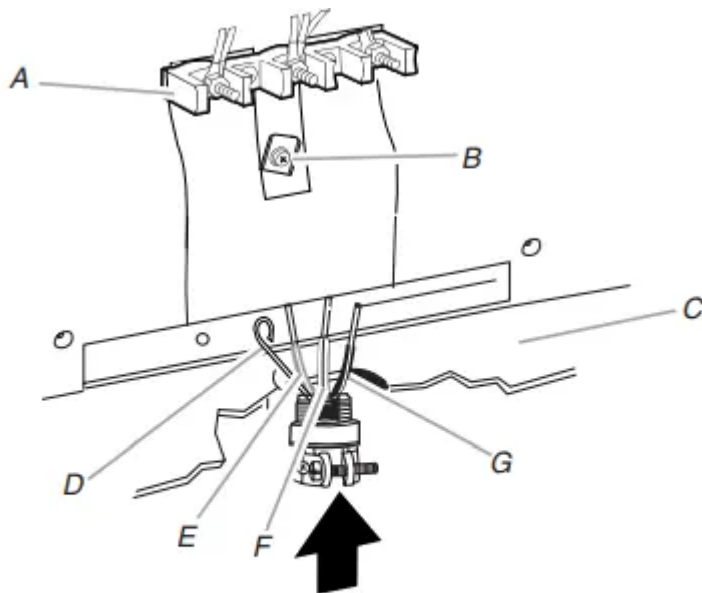

- A. Terminal block
- B. Ground-link screw
- C. Cord/conduit plate
- D. Bare (green) ground wire
- E. Line 2 (red) wire
- F. Neutral (white) wire
- G. Line 1 (black) wire

4. Attach terminal lugs to line 1 (black), neutral (white), and line 2 (red) wires. Loosen (do not remove) the setscrew on the front of the terminal lug and insert exposed wire end through bottom of terminal lugs. Securely tighten setscrew to torque as shown in the following Bare Wire Torque Specifications chart

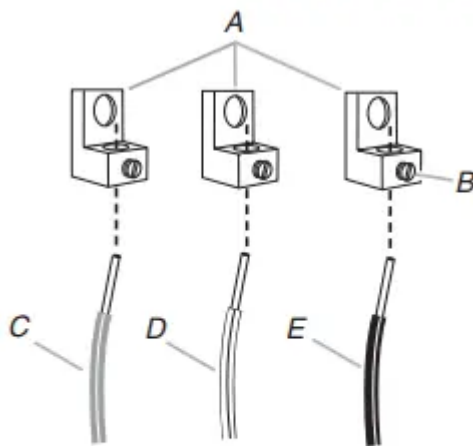

- A. Terminal lug
- B. Setscrew
- C. Line 2 (red) wire
- D. Neutral (white) wire
- E. Line 1 (black) wire

Bare Wire Torque Specifications

Attaching terminal lugs to the terminal block - 20 lbs-in. (2.3 N-m)



Wire Awg	Torque
8 gauge copper	25 lbs-in. (2.8 N-m)
6 gauge aluminum	35 lbs-in. (4.0 N-m)

- Use a hex or Phillips screwdriver to connect the bare (green) ground wire to the range with the ground-link screw and ground-link section. The ground wire must be attached over the ground-link section and must not contact any other terminal.
- Use 3/8" (9.5 mm) nut driver to connect the neutral (white) wire to the center terminal block post with one of the 10-32 hex nuts.

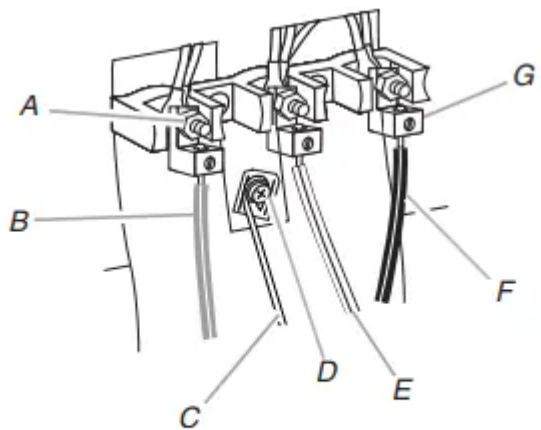

- A. 10-32 hex nut
 B. Line 2 (red) wire
 C. Bare (green) ground wire
 D. Ground-link screw
 E. Neutral (white) wire
 F. Line 1 (black) wire
 G. Terminal lug

- Connect line 2 (red) and line 1 (black) wires to the outer terminal block posts with 10-32 hex nuts.
 - Firmly tighten hex nuts.
- IMPORTANT:** Verify the tightness of the hex nuts.
- Replace lower access cover.

Verify Anti-Tip Bracket Is Installed and Engaged

On Ranges Equipped with a Premium Storage Drawer:

- Slide range into final location, making sure rear leveling leg slides into anti-tip bracket.
- Remove the premium storage drawer. See the "Remove/ Replace Drawer" section.
- Use a flashlight to look underneath the bottom of the range.
- Visually check that the rear range foot is inserted into the slot of the anti-tip bracket.

On Ranges Equipped with a Warming Drawer or Baking Drawer:

1. Slide range into final location, making sure rear leveling leg slides into anti-tip bracket. Leave a 1" (2.5 cm) gap between the back of the range and the back wall.
2. Place the outside of your foot against the bottom front of the warming drawer or baking drawer to keep the range from moving, and then grasp the back of the range, as shown.

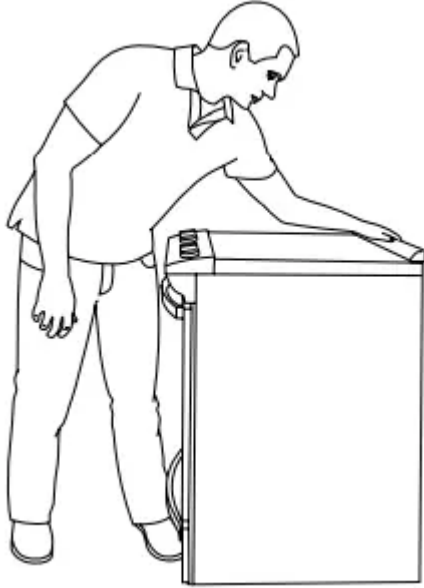

3. Slowly attempt to tilt the range forward. If you encounter immediate resistance, the range foot is engaged in the anti-tip bracket. Go to Step 8.

4. If the rear of the range lifts more than 1/2" (1.3 cm) off the floor without resistance, stop tilting the range and lower it gently back to the floor. The range foot is not engaged in the anti-tip bracket.

IMPORTANT: If there is a snapping or popping sound when lifting the range, the range may not be fully engaged in the bracket. Check to see if there are obstructions keeping the range from sliding to the wall or keeping the range foot from sliding into the bracket. Verify that the bracket is held securely in place by the mounting screws.

5. Slide the range forward, and verify that the anti-tip bracket is securely attached to the floor or wall.

6. Slide range back so the rear range foot is inserted into the slot of the anti-tip bracket.

7. Repeat steps 1 and 2 to ensure that the range foot is engaged in the anti-tip bracket. If the rear of the range lifts more than 1/2" (1.3 cm) off the floor without resistance, the anti-tip bracket may not be installed correctly. Do not operate the range without anti-tip bracket installed and engaged. Please reference the "Warranty" section of the User Guide to contact service.

8. Move the range into its final location. Check that the range is level by placing a level on the oven bottom. See the "Level Range" section.

IMPORTANT: If the range is moved to adjust the leveling legs, verify that the anti-tip bracket is engaged by repeating steps 1 to 8

Remove/Replace Drawer

Remove all items from inside the baking drawer, and then allow the range to cool completely before attempting to remove the drawer.

To Remove:

1. Open the drawer to its fully open position.
2. Using a flat-blade screwdriver, gently loosen the drawer from the glide alignment notch, and then lift up the drawer alignment tab from the glide.

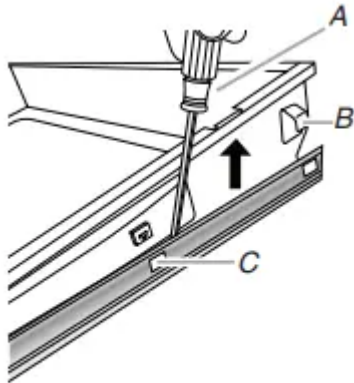

A. Flat-blade screwdriver
B. Drawer alignment tab
C. Drawer glide notch

3. Repeat Step 2 on the other side. The drawer is no longer attached to the drawer glides. Using both hands, pick up the drawer to complete the removal

To Replace:

1. Align the forward drawer notches with the notches in the drawer glides on both sides. Place the rear alignment tabs into the drawer glides on both sides.

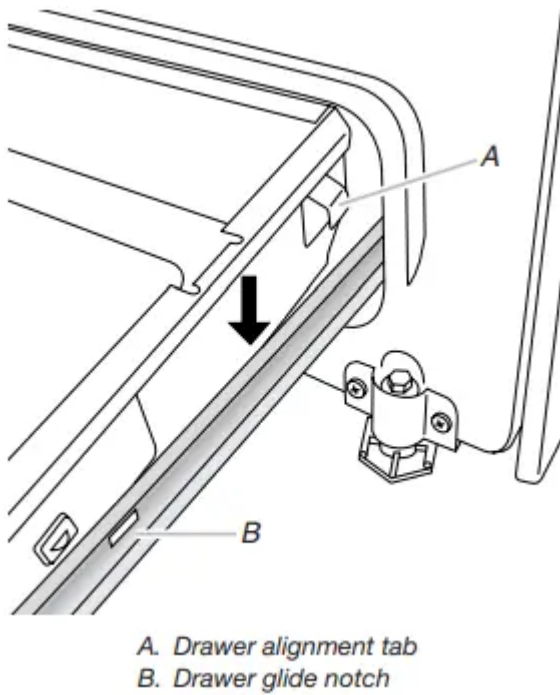

2. Push the drawer in all the way.
3. Gently open and close the drawer to ensure it is seated properly on the glides on both sides.

Oven Door

For normal range use, it is not suggested to remove the oven door. However, if removal is necessary, make sure the oven is off and cool. Then, follow these instructions. The oven door is heavy

To Remove:

1. Open oven door all the way.
2. Pinch the hinge latch between 2 fingers and pull forward. Repeat on other side of oven door.

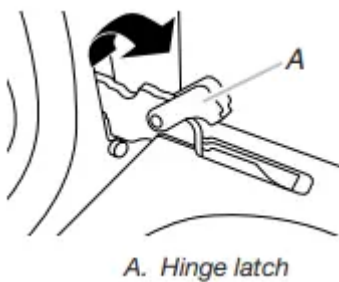

3. Close the oven door as far as it will shut.
4. Lift the oven door while holding both sides. Continue to push the oven door closed and pull it away from the oven door frame.



To Replace:

1. Insert both hanger arms into the door. Be sure that the hinge notches are engaged in the oven door frame.

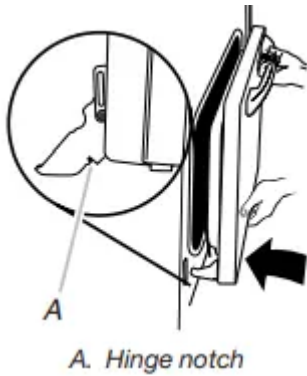

2. Open the oven door. The door should be able to open all the way.
3. Move the hinge levers back to the locked position. Check that the door is free to open and close and is level while closed. If it is not, repeat the removal and installation procedures.

FEATURE GUIDE

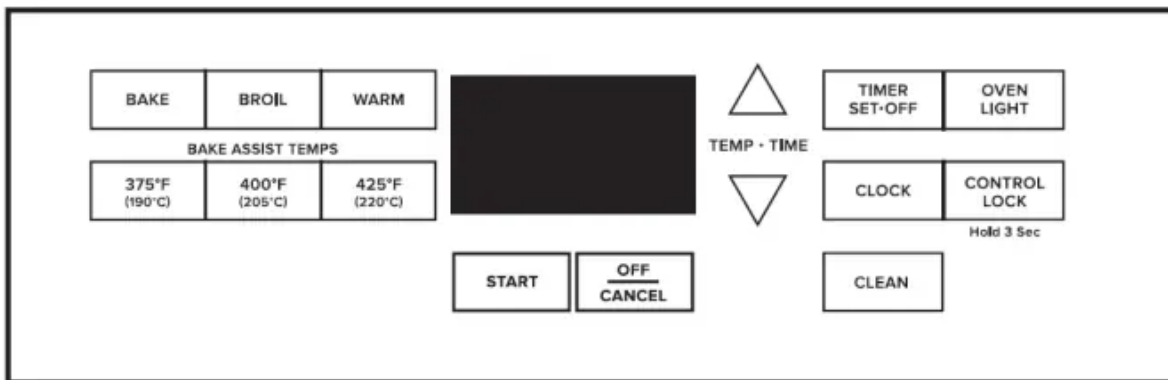

KEYPAD	FEATURE	INSTRUCTIONS
CLOCK	Clock	<p>This clock uses a 12 hour cycle.</p> <ol style="list-style-type: none"> 1. Check that the oven is OFF. 2. Press CLOCK. 3. Press the Temp/Time “up” or “down” arrow keypad to set the hours. Press CLOCK to switch to the minutes. Press the Temp/Time “up” or “down” arrow keypad to set the minutes. 4. Press CLOCK or START
Oven LIGHT	Oven cavity light	<p>While the oven door is closed, press OVEN LIGHT to turn the light on and off. The oven light will come on when the oven door is opened. The oven light will not come on during the Self-Cleaning cycle.</p>
TIMER SET/OFF	Oven timer	<p>The Timer can be set in hours or minutes up to 9 hours and 59 minutes.</p> <ol style="list-style-type: none"> 1. Press TIMER SET/OFF. 2. Press the Temp/Time “up” or “down” arrow keypad to set the length of time. 3. Press START to begin the countdown. If enabled, end-of-cycle tones will sound at end of countdown. 4. Press TIMER SET•OFF to cancel the Timer. Do not press OFF/CANCEL because the oven will turn off.
START	Cooking start	<p>The Start keypad begins any oven function. If Start is not pressed within 10 seconds, a tone will sound and Start will blink until pressed or canceled. If Start is not pressed within 30 seconds after pressing a keypad, the function is canceled and the time of day is displayed</p>
OFF/CANCEL	Range function	<p>The Cancel keypad stops any oven function except the Oven Control Lockout and Timer</p>
TEMP/TIME	Temperature and time adjust	<p>The Temp/Time “up” and “down” arrow keypads are used to adjust time and temperature settings.</p>
BAKE		<ol style="list-style-type: none"> 1. Press BAKE

	Baking and roasting	<ol style="list-style-type: none"> 2. Press the Temp/Time “up” or “down” arrow keypad until desired temperature is reached. A tone will sound if the minimum or maximum temperature is reached. 3. Press START. 4. To change the temperature, repeat steps 2. Press START. 5. Press OFF/CANCEL when finished. <p>NOTE: On models with convection, the convection fan will shut off when the oven door is opened. If the oven door remains open for too long, the heating elements will shut off until the oven door is closed. All timers, including any active Cook Time or Timed Cook functions, will continue to count down.</p>
BAKE ASSIST TEMPS	Baking and roasting	<ol style="list-style-type: none"> 1. Press the desired Bake Assist Temp keypad. 2. Press the Temp/Time “up” or “down” arrow keypad to set a temperature other than the Bake Assist Temperature. A tone will sound if the minimum or maximum temperature is reached. 3. Press START. 4. Press OFF/CANCEL when finished. <p>NOTE: On models with convection, the convection fan will shut off when the oven door is opened. If the oven door remains open for too long, the heating elements will shut off until the oven door is closed. All timers, including any active Cook Time or Timed Cook functions, will continue to count down.</p>
BROIL	Broiling	<ol style="list-style-type: none"> 1. Position cookware in the oven and close the oven door. 2. Press BROIL. 3. Press the Temp/Time “up” or “down” arrow keypad until the desired temperature is reached. A tone will sound if the minimum or maximum temperature is reached. 4. Press START. 5. To change the temperature, repeat Step 3 and press START. 6. Press OFF/CANCEL when finished.

		<p>NOTE: On models with convection, the convection fan will shut off when the oven door is opened. If the oven door remains open for too long, the heating elements will shut off until the oven door is closed. All timers, including any active Cook Time or Timed Cook functions, will continue to count down</p>
WARM	Hold warm	<p>Food must be at serving temperature before placing it in the warmed oven.</p> <ol style="list-style-type: none"> 1. Press WARM. 2. Press the Temp/Time “up” or “down” arrow keypad until desired temperature is reached. A tone will sound if the minimum or maximum temperature is reached. 3. Press START. 4. Press OFF/CANCEL when finished. <p>NOTE: On some models: The oven will automatically turn off after 60 minutes.</p> <p>NOTE: On models with convection, the convection fan will shut off when the oven door is opened. If the oven door remains open for too long, the heating elements will shut off until the oven door is closed. All timers, including any active Cook Time or Timed Cook functions, will continue to count down.</p>
CLEAN (On some models)	Self-Cleaning cycle	See the “Self-Cleaning Cycle” section in the Owner’s Manual.
CONTROL LOCK (Hold 3 sec.)	Oven control lockout	<p>No keypads will function with the controls locked.</p> <ol style="list-style-type: none"> 1. Check that the oven is off. 2. Press and hold CONTROL LOCK keypad for 3 seconds. 3. A tone will sound and a lock will be displayed. 4. Repeat to unlock.A

Warning



This content is compiled from multiple sources and is provided for reference purposes only. It may not be complete or fully applicable to all situations. If you are unable to resolve your issue, please contact the product manufacturer or an authorized service provider for official support.

Document generated by [ManualsFile](#)

