

TOOL SPECIFICATIONS

All screws and nuts are metric.

MODEL	TOOL ACTUATION	LENGTH	HEIGHT	WIDTH	WEIGHT
SB-1842BN	Sequential Trip	9.25"	8.5"	2"	2.38 lbs.
SB-1850BN	Sequential Trip	9.25"	9.5"	2"	2.69 lbs.
SB-150SX	Sequential Trip	9.50"	8.75"	2"	2.65 lbs.
SB-1664FN	Sequential Trip	11.25"	11.50"	3"	4.03 lbs.
SB-150SXHD-1	Contact Trip	10.50"	10.50"	3"	3.72 lbs.
SB-150SXHD-2	Sequential Trip	10.50"	10.50"	3"	3.72 lbs.
SB-150SXHD-3	Trigger Operated	10.50"	10.50"	3"	3.61 lbs.
SB-2IN1	Sequential Trip	9.25"	8.5"	2"	2.38 lbs.

FASTENER SPECIFICATIONS:

TOOL MODEL	BRAD SERIES	GAUGE	FASTENER RANGE
SB-1842BN	BT1300	18	5/8" - 1-5/8"
SB-1850BN	BT1300	18	5/8" - 2"
SB-2 IN 1	BT1300	18	5/8" - 1-5/8"
TOOL MODEL	STAPLE SERIES	CROWN WIDTH	FASTENER RANGE
SB-150SX/SB-150SXHD	SX5035	5-6mm	1/2" - 1-1/2"
SB-2 IN 1	SX5035	5-6mm	1/2" - 1-1/2"
TOOL MODEL	NAIL SERIES	GAUGE	FASTENER RANGE
SB-1664FN	SB16	16	1" - 2-1/2"

TOOL AIR FITTING:

These tools use a free-flow connector plug, 1/4 N.P.T. The inside diameter should be .200" (5mm) or larger. The fitting must be capable of discharging tool air pressure when disconnected from the air supply.

OPERATING PRESSURE:

70 to 100 p.s.i.g. (4.9 to 7.0 kg/cm²)

Select the operating pressure within this range for best fastener performance.

DO NOT EXCEED THIS RECOMMENDED OPERATING PRESSURE.

OPERATION

BOSTITCH OFFERS THREE TYPES OF OPERATION.

CONTACT TRIP

The common operating procedure on "Contact Trip" tools is for the operator to contact the work to actuate the trip mechanism while keeping the trigger pulled, thus driving a fastener each time the

work is contacted. This will allow rapid fastener placement on many jobs, such as sheathing, decking and pallet assembly.

All pneumatic tools are subject to recoil when driving fasteners. The tool may bounce, releasing the trip, and if unintentionally allowed to recontact the work surface with the trigger still actuated (finger still holding trigger pulled) an unwanted second fastener will be driven.

SEQUENTIAL TRIP

The Sequential Trip requires the operator to hold the tool against the work before pulling the trigger. This makes accurate fastener placement easier, for instance on framing, toe nailing and crating applications.

The Sequential Trip allows exact fastener location without the possibility of driving a second fastener on recoil, as described under “Contact Trip”.

The Sequential Trip Tool has a positive safety advantage because it will not accidentally drive a fastener if the tool is contacted against the work – or anything else – while the operator is holding the trigger pulled.

TRIGGER OPERATED

The Trigger Operated model is cycled by actuation of the trigger only. This model does not have a Contact Arm and is intended for use only where a Contact Arm CANNOT be used to satisfy the requirements of the application. The Trigger Operated tool will cycle each time the trigger is actuated.

MODEL IDENTIFICATION:

Refer to Operation Instructions on page 4 before proceeding to use this tool

CONTACT TRIP
Identified by:
BLACK TRIGGER

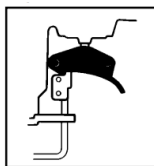

SEQUENTIAL TRIP
Identified by:
GRAY TRIGGER



TRIGGER OPERATED
Identified by:
BLACK TRIGGER

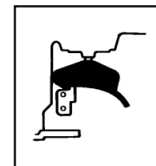

WARNING Do not use oxygen, combustible gases, or bottled gases as a power source for this tool as tool may explode, possibly causing injury.

FITTINGS:

Install a male plug on the tool which is free flowing and which will release air pressure from the tool when disconnected from the supply source.

HOSES:

Air hoses should have a minimum of 150 p.s.i. (10.6 kg/cm² working pressure rating or 150 percent of the maximum pressure that could be produced in the air system. The supply hose should contain a fitting that will provide “quick disconnecting” from the male plug on the tool.

SUPPLY SOURCE:

Use only clean regulated compressed air as a power source for this tool. NEVER USE OXYGEN, COMBUSTIBLE GASES, OR BOTTLED GASES, AS A POWER SOURCE FOR THIS TOOL AS TOOL MAY EXPLODE.

REGULATOR:

A pressure regulator with an operating pressure of 0 - 125 p.s.i. (0 - 8.79 KG/CM² is required to control the operating pressure for safe operation of this tool. Do not connect this tool to air pressure which can potentially exceed 200 p.s.i. (14 KG/CM² as tool may fracture or burst, possibly causing injury.

OPERATING PRESSURE:

Do not exceed recommended maximum operating pressure as tool wear will be greatly increased. The air supply must be capable of maintaining the operating pressure at the tool.

Pressure drops in the air supply can reduce the tool's driving power. Refer to “TOOL SPECIFICATIONS” for setting the correct operating pressure for the tool.

FILTER:

Dirt and water in the air supply are major causes of wear in pneumatic tools. A filter will help to get the best performance and minimum wear from the tool. The filter must have adequate flow capacity for the specific installation. The filter has to be kept clean to be effective in providing clean compressed air to the tool. Consult the manufacturer's instructions on proper maintenance of your filter. A dirty and clogged filter will cause a pressure drop which will reduce the tool's performance.

OPERATION

1. TRIGGER OPERATION

A TRIGGER OPERATED tool requires a single action to drive a fastener. Each time the trigger is pulled the tool will drive a fastener. The trigger operated model is intended for use only when a contact trip or sequential trip cannot be used due to the requirements of the application.

2. CONTACT TRIP OPERATION

The CONTACT TRIP MODEL tool contains a contact trip that operates in conjunction with the trigger to drive a fastener. There are two methods of operation to drive fasteners with a contact trip tool.

A. SINGLE FASTENER PLACEMENT: To operate the tool in this manner, first position the contact trip on the work surface, WITHOUT PULLING THE TRIGGER. Depress the contact trip until the nose touches the work surface and then pull the trigger to drive a fastener. Do not press the tool against the work with extra force. Instead, allow the tool to recoil off the work surface to avoid a second unwanted fastener. Remove your finger from the trigger after each operation.

B. RAPID FASTENER OPERATION: To operate the tool in this manner, hold the tool with the contact trip pointing towards but not touching the work surface. Pull the trigger and then tap the contact trip against the work surface using a bouncing motion. Each depression of the contact trip will cause a fastener to be driven.

There are three available systems on BOSTITCH pneumatic tools. They are: TRIGGER OPERATION 2. CONTACT TRIP OPERATION 3. SEQUENTIAL TRIP OPERATION

WARNING

The operator must not hold the trigger pulled on contact trip tools except during fastening operation, as serious injury could result if the trip accidentally contacted someone or something, causing the tool to cycle.

Keep hands and body away from the discharge area of the tool. A contact trip tool may bounce from the recoil of driving a fastener and an unwanted second fastener may be driven, possibly causing injury.

3. SEQUENTIAL TRIP OPERATION:

The SEQUENTIAL TRIP MODEL contains a contact trip that operates in conjunction with the trigger to drive a fastener. To operate a sequential trip tool, first position the contact trip on the work surface WITHOUT PULLING THE TRIGGER. Depress the contact trip and then pull the trigger to drive a fastener. As long as the contact trip is contacting the work and is held depressed, the tool will drive a fastener each time the trigger is depressed. If the contact trip is allowed to leave the work surface, the sequence described above must be repeated to drive another fastener.

TOOL OPERATION CHECK:

CAUTION: Remove all fasteners from tool before performing tool operation check.

1. TRIGGER OPERATED TOOL:

- A. With finger off the trigger, hold the tool with a firm grip on the handle.
- B. Place the nose of the tool against the work surface.
- C. Pull the trigger to drive. Release the trigger and cycle is complete.

CAUTION: THE TOOL WILL CYCLE EACH TIME THE TRIGGER IS PULLED!

2. CONTACT TRIP OPERATION:

- A. With finger off the trigger, press the contact trip against the work surface.

THE TOOL MUST NOT CYCLE.

- B. Hold the tool off the work surface, and pull the trigger.

THE TOOL MUST NOT CYCLE.

- C. With the tool off the work surface, pull the trigger.

Press the contact trip against the work surface.

THE TOOL MUST CYCLE.

- D. Without touching the trigger, press the contact trip against the work surface, then pull the trigger.

THE TOOL MUST CYCLE.

3. SEQUENTIAL TRIP OPERATION:

- A. Press the contact trip against the work surface, without touching the trigger.

THE TOOL MUST NOT CYCLE.

- B. Hold the tool off the work surface and pull the trigger.

THE TOOL MUST NOT CYCLE.

Release the trigger. The trigger must return to the trigger stop on the frame.

- C. Pull the trigger and press the contact trip against the work surface.

THE TOOL MUST NOT CYCLE.

- D. With finger off the trigger, press the contact trip against the work surface. Pull the trigger.

THE TOOL MUST CYCLE.

IN ADDITION TO THE OTHER WARNINGS CONTAINED IN THIS MANUAL OBSERVE THE FOLLOWING FOR SAFE OPERATION

- Use the BOSTITCH pneumatic tool only for the purpose for which it was designed.

- Never use this tool in a manner that could cause a fastener to be directed toward the user or others in the work area.
- Do not use the tool as a hammer.
- Always carry the tool by the handle. Never carry the tool by the air hose.
- Do not alter or modify this tool from the original design or function without approval from BOSTITCH, INC.
- Always be aware that misuse and improper handling of this tool can cause injury to yourself and others.
- Never clamp or tape the trigger or contact trip in an actuated position.
- Never leave a tool unattended with the air hose attached.
- Do not operate this tool if it does not contain a legible WARNING LABEL.
- Do not continue to use a tool that leaks air or does not function properly. Notify your nearest Bostitch representative if your tool continues to experience functional problems.

LUBRICATION

Frequent, but not excessive, lubrication is required for best performance. Oil added through the air line connection will lubricate the internal parts. Use BOSTITCH Air Tool Lubricant, Mobil Velocite #10, or equivalent. Do not use detergent oil or additives as these lubricants will cause accelerated wear to the seals and bumpers in the tool, resulting in poor tool performance and frequent tool maintenance.

If no airline lubricator is used, add oil during use into the air fitting on the tool once or twice a day.

Only a few drops of oil at a time is necessary. Too much oil will only collect inside the tool and will be noticeable in the exhaust cycle.

COLD WEATHER OPERATION:

For cold weather operation, near and below freezing, the moisture in the air line may freeze and prevent tool operation. We recommend the use of BOSTITCH WINTER FORMULA air tool lubricant or permanent antifreeze (ethylene glycol) as a cold weather lubricant.

CAUTION: Do not store tools in a cold weather environment to prevent frost or ice formation on the tools operating valves and mechanisms that could cause tool failure.

NOTE: Some commercial air line drying liquids are harmful to “O”-rings and seals – do not use these low temperature air dryers without checking compatibility.

LOADING THE TOOL

LOADING THE SB-1842BN/SB-1850BN/SB-2IN1





WARNING EYE PROTECTION which conforms to ANSI specifications and provides protection against flying particles both from the FRONT and SIDE should ALWAYS be worn by the operator and others in the work area when loading, operating or servicing this tool. Eye protection is required to guard against flying fasteners and debris, which could cause severe eye injury.

The employer and/or user must ensure that proper eye protection is worn. Eye protection equipment must conform to the requirements of the American National Standards Institute, ANSI Z87.1-1989 and provide both frontal and side protection.

NOTE: Non-side shielded spectacles and face shields alone do not provide adequate protection.

WARNING TO PREVENT ACCIDENTAL INJURIES:

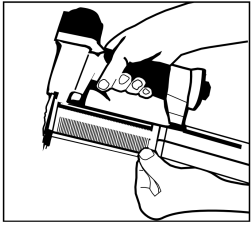
- Never place a hand or any other part of the body in nail discharge area of tool while the air supply is connected.
- Never point the tool at anyone else.
- Never engage in horseplay.
- Never pull the trigger unless nose is directed at the work.
- Always handle the tool with care.
- Do not pull the trigger or depress the trip mechanism while loading the tool.

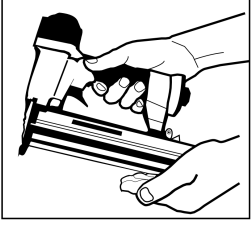
		
<p>1. Disengage the latch and pull back magazine side.</p>	<p>2. With magazine fully open insert fasteners. Points must be against bottom of magazine.</p>	<p>2. With magazine fully open insert fasteners.</p>
		
<p>3. Push magazine forward.</p>	<p>4. Continue pushing until latch is engaged.</p>	

LOADING THE SB-150SX

	<p>WARNING EYE PROTECTION which conforms to ANSI specifications and provides protection against flying particles both from the FRONT and SIDE should ALWAYS be worn by the operator and others in the work area when loading, operating or servicing this tool. Eye protection is required to guard against flying fasteners and debris, which could cause severe eye injury.</p> <p>The employer and/or user must ensure that proper eye protection is worn. Eye protection equipment must conform to the requirements of the American National Standards Institute, ANSI Z87.1-1989 and provide both frontal and side protection.</p> <p>NOTE: Non-side shielded spectacles and face shields alone do not provide adequate protection.</p>
-------------------------------------------------------------------------------------	------------------------------------------------------------------------------------------------------------------------------------------------------------------------------------------------------------------------------------------------------------------------------------------------------------------------------------------------------------------------------------------------------------------------------------------------------------------------------------------------------------------------------------------------------------------------------------------------------------------------------------------------------------------------------------------------------------------------------------------------------------

WARNING TO PREVENT ACCIDENTAL INJURIES:

- Never place a hand or any other part of the body in nail discharge area of tool while the air supply is connected.

- Never point the tool at anyone else.
- Never engage in horseplay.
- Never pull the trigger unless nose is directed at the work.
- Always handle the tool with care.
- Do not pull the trigger or depress the trip mechanism while loading the tool.

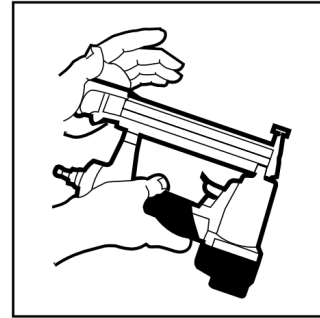
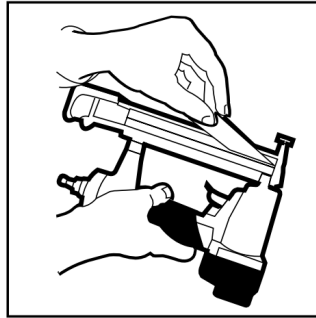
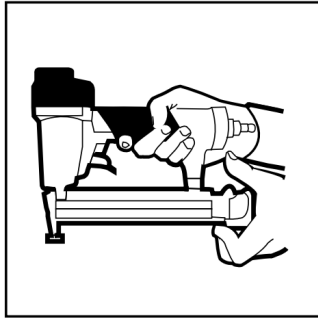

1. Disengage the latch and pull back on the staple guide unit.
2. Insert the staples into the magazine. CAUTION: Load with points upward.
3. Push the staple guide unit closed, until the latch engages.

LOADING THE SB-1664FN



WARNING EYE PROTECTION which conforms to ANSI specifications and provides protection against flying particles both from the FRONT and SIDE should ALWAYS be worn by the operator and others in the work area when loading, operating or servicing this tool. Eye protection is required to guard against flying fasteners and debris, which could cause severe eye injury.

The employer and/or user must ensure that proper eye protection is worn. Eye protection equipment must conform to the requirements of the American National Standards Institute, ANSI Z87.1-1989 and provide both frontal and side protection.

NOTE: Non-side shielded spectacles and face shields alone do not provide adequate protection.

WARNING TO PREVENT ACCIDENTAL INJURIES:

- Never place a hand or any other part of the body in nail discharge area of tool while the air supply is connected.
- Never point the tool at anyone else.
- Never engage in horseplay.

- Never pull the trigger unless nose is directed at the work.
- Always handle the tool with care.
- Do not pull the trigger or depress the trip mechanism while loading the tool.

1. LOAD NAILS:

Pull follower back until it latches. (fig. 1)	
Insert nails into track of magazine (fig. 2)	
Insert nails into track of magazine (fig. 2)	

MAINTAINING THE PNEUMATIC TOOL

WARNING When working on air tools, note the warnings in this manual and use extra care evaluating problem tools.

CAUTION: Pusher spring (constant force spring). Caution must be used when working with the spring assembly. The spring is wrapped around, but not attached to, a roller. If the spring is extended beyond its length, the end will come off the roller and the spring will roll up with a snap, with a chance of pinching your hand. Also the edges of the spring are very thin and could cut. Care must also be taken to insure no permanent kinks are put in the spring as this will reduce the springs force.

REPLACEMENT PARTS:

BOSTITCH replacement parts are recommended. Do not use modified parts or parts which will not give equivalent performance to the original equipment.

ASSEMBLY PROCEDURE FOR SEALS:

When repairing a tool, make sure the internal parts are clean and lubricated. Use Parker "O"-LUBE or equivalent on all "O"-rings. Coat each "O"-ring with "O"-LUBE before assembling. Use a small amount of oil on all moving surfaces and pivots. After reassembly add a few drops of BOSTITCH Air Tool Lubricant through the air line fitting before testing.

AIR SUPPLY-PRESSURE AND VOLUME:

Air volume is as important as air pressure. The air volume supplied to the tool may be inadequate because of undersize fittings and hoses, or from the effects of dirt and water in the system.

Restricted air flow will prevent the tool from receiving an adequate volume of air, even though the pressure reading is high. The results will be slow operation, misfeeds or reduced driving power.

Before evaluating tool problems for these symptoms, trace the air supply from the tool to the supply source for restrictive connectors, swivel fittings, low points containing water and anything else that would prevent full volume flow of air to the tool.

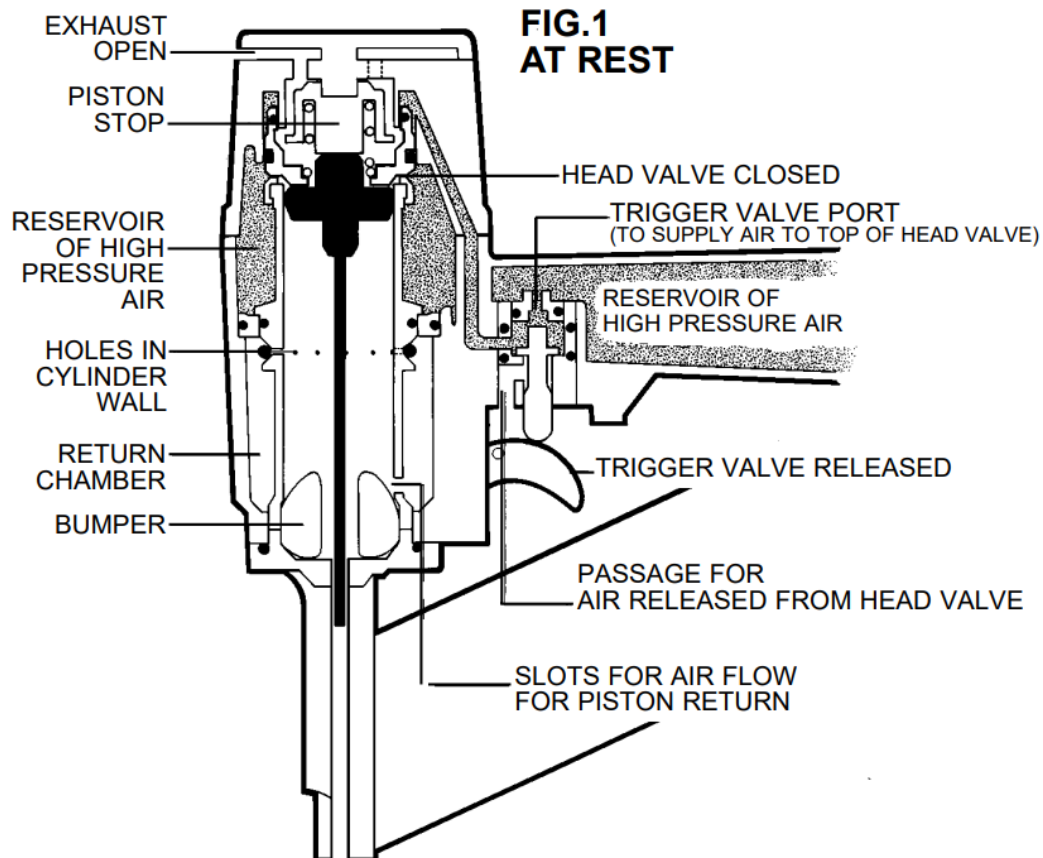

**FIG.2
DRIVING STROKE**

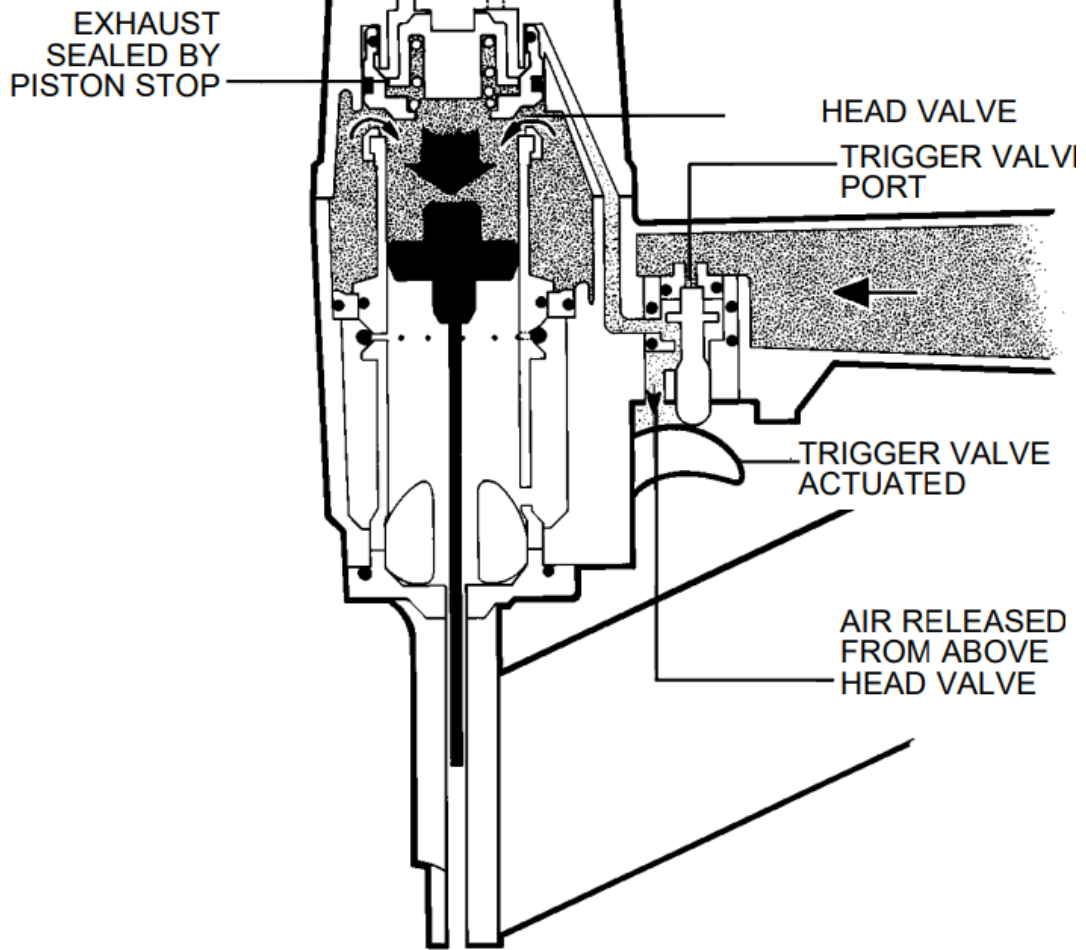

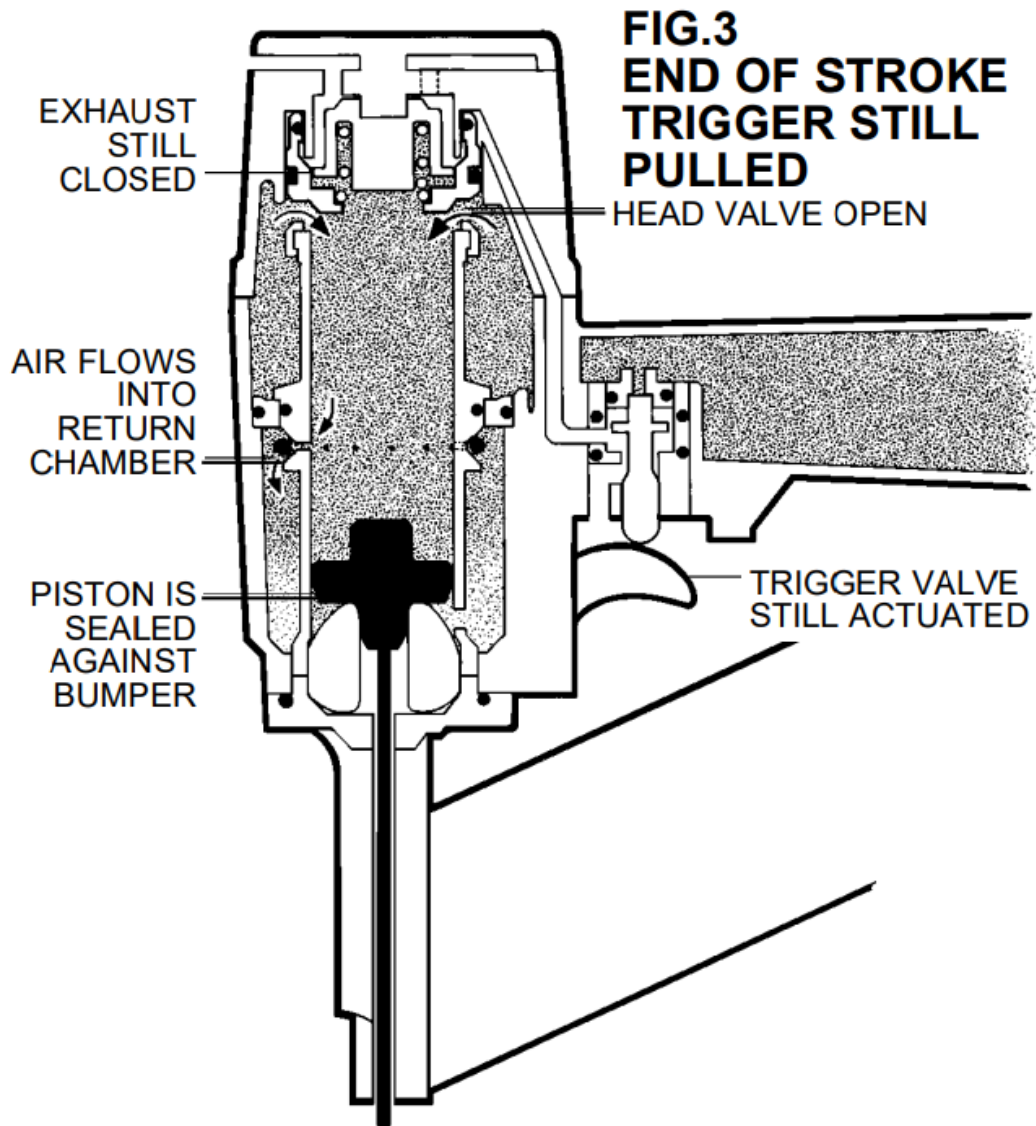

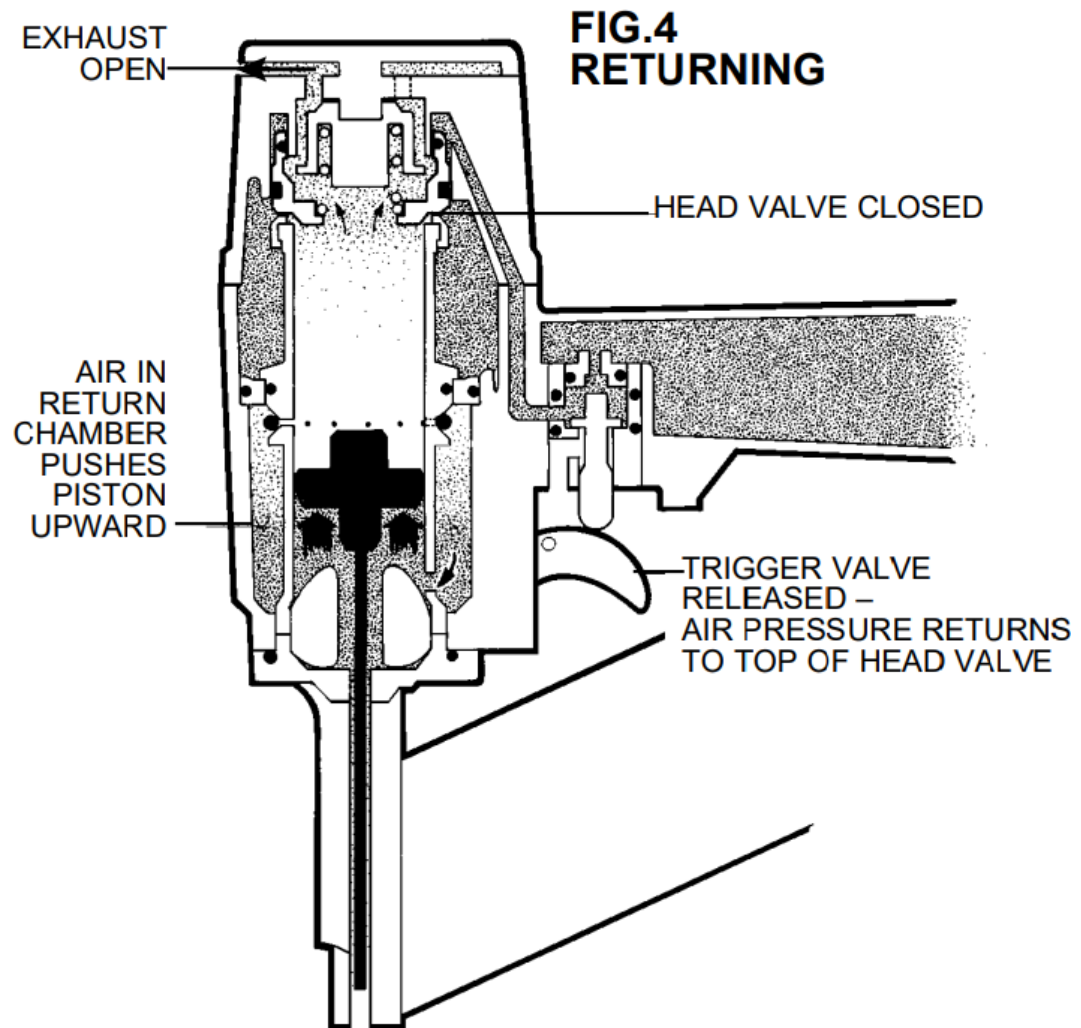

TROUBLESHOOTING



PROBLEM	CAUSE	CORRECTION
Trigger valve housing leaks air	O-ring cut or cracked	Replace O-ring
Trigger valve stem leaks air	O-ring/seals cut or cracked	Replace trigger valve assembly
Frame/nose leaks air	Loose nose screws	Tighten and recheck
	O-ring or Gasket is cut or cracked	Replace O-ring or gasket
	O-ring or Gasket is cut or cracked	Replace O-ring or gasket
Frame/cap leaks air	Damaged gasket or seal	Replace gasket or seal
	Cracked/worn head valve bumper	Replace bumper
	Loose cap screws	Tighten and recheck
Failure to cycle	Air supply restriction	Check air supply equipment
	Tool dry, lack of lubrication	Use BOSTITCH Air Tool Lubricant
	Worn head valve O-rings	Replace O-rings
	Broken cylinder cap spring	Replace cylinder cap spring
	Head valve stuck in cap	Disassemble/Check/Lubricate
Lack of power; slow to cycle	Tool dry, lacks lubrication	Use BOSTITCH Air Tool Lubricant
	Broken cylinder cap spring	Replace cap spring
	O-rings/seals cut or cracked	Replace O-rings/seals
	Exhaust blocked	Check bumper, head valve spring, muffler
	Trigger assembly worn/leaks	Replace trigger assembly
	Dirt/tar build up on driver	Disassemble nose/driver to clean

PROBLEM	CAUSE	CORRECTION
	Cylinder sleeve not seated correctly on bottom bumper	Disassemble to correct
	Head valve dry	Disassemble/lubricate
	Air pressure too low	Check air supply equipment
Skipping fasteners; intermittent feed	Worn bumper	Replace bumper
	Tar/dirt in driver channel	Disassemble and clean nose and driver
	Air restriction/inadequate air flow through quick disconnect socket and plug	Replace quick disconnect fittings
	Worn piston O-ring	Replace O-ring, check driver
	Tool dry, lacks lubrication	Use BOSTITCH Air Tool Lubricant
	Damaged pusher spring	Replace spring
	Damaged pusher spring	Replace spring
	Loose magazine nose screws	Tighten all screws
	Fasteners too short for tool	Use only recommended fasteners
	Bent fasteners	Discontinue using these fasteners
	Wrong size fasteners	Use only recommended fasteners
	Leaking head cap gasket	Tighten screws/replace gasket
	Trigger valve O-ring cut/worn	Replace O-ring
	Broken/chipped driver	Replace driver (check piston O-ring)
	Dry/dirty magazine	Clean/lubricate use BOSTITCH Air Tool Lubricant



PROBLEM	CAUSE	CORRECTION
	Worn magazine	Replace magazine
Fasteners jam in tool	Driver channel worn	Replace nose/check door
	Wrong size fasteners	Use only recommended fasteners
	Bent fasteners	Discontinue using these fasteners
	Loose magazine/nose screws	Tighten all screws
	Broken/chipped driver	Replace driver

WARNING Always disconnect air supply: 1. Before making adjustments; 2. When servicing the tool; 3. When clearing a jam; 4. When tool is not in use; 5. When moving to a different work area, as accidental actuation may occur, possibly causing injury.

SB-1842BN, SB1850BN, SB-1664FN FASTENER CONTROL ADJUSTMENT

The Fastener Control adjustment feature provides close control of the fastener drive depth; from flush with the work surface to shallow or deep countersink. First, set the air pressure for consistent drive in the specific work. Then use the Fastener Control adjustment to give the desired depth of drive.

TO ADJUST FASTENER CONTROL ADJUSTMENT:

1. With air pressure set, drive a few fasteners into a representative material sample to determine if adjustment is necessary.
2. If adjustment is required, disconnect air supply

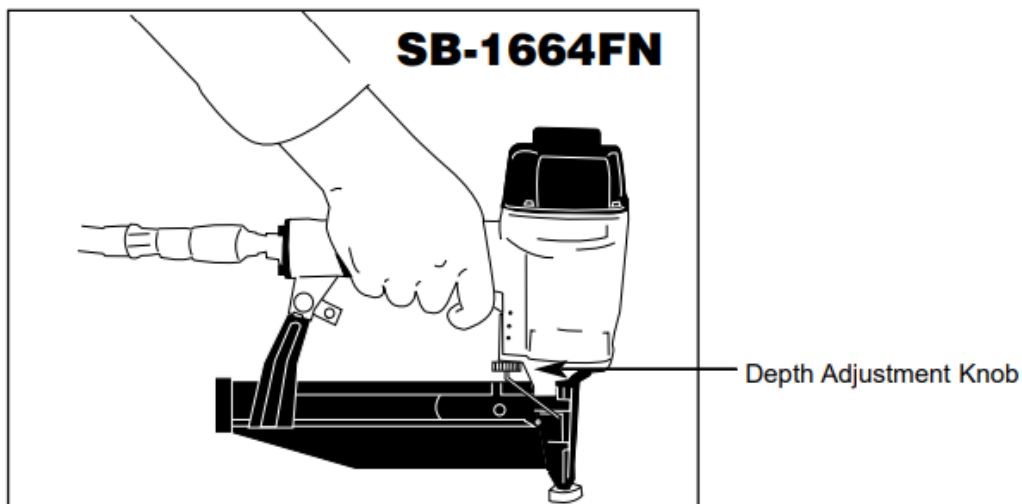

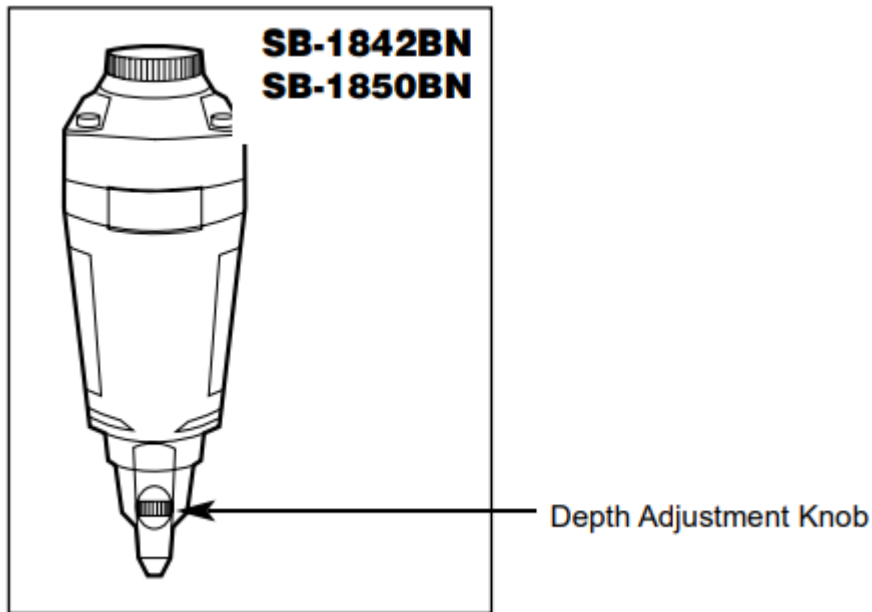

SAFETY INSTRUCTIONS

	<p>WARNING EYE PROTECTION which conforms to ANSI specifications and provides protection against flying particles both from the FRONT and SIDE should ALWAYS be worn by the operator and others in the work area when loading, operating or servicing this tool. Eye protection is required to guard against flying fasteners and debris, which could cause severe eye injury.</p> <p>The employer and/or user must ensure that proper eye protection is worn. Eye protection equipment must conform to the requirements of the American National Standards Institute, ANSI Z87.1-1989 and provide both frontal and side protection.</p> <p>NOTE: Non-side shielded spectacles and face shields alone do not provide adequate protection.</p>
	<p>CAUTION: ADDITIONAL SAFETY PROTECTION will be required in some environments. For example, the working area may include exposure to noise level which can lead to hearing damage. The employer and user must ensure that any necessary hearing protection is provided and used by the operator and others in the work area.</p> <p>Some environments will require the use of head protection equipment. When required, the employer and user must ensure that head protection conforming to ANSI Z89.1 1986 is used.</p>

AIR SUPPLY AND CONNECTIONS

WARNING

- Do not use oxygen, combustible gases, or bottled gases as a power source for this tool as tool may explode, possibly causing injury.
- Do not use supply sources which can potentially exceed 200 P.S.I.G. as tool may burst, possibly causing injury.
- The connector on the tool must not hold pressure when air supply is disconnected. If a wrong fitting is used, the tool can remain charged with air after disconnecting and thus will be able to drive a fastener even after the air line is disconnected possibly causing injury.
- Do not pull trigger or depress contact arm while connected to the air supply as the tool may cycle, possibly causing injury.
- Always disconnect air supply: 1.) Before making adjustments; 2.) When servicing the tool; 3.) When clearing a jam; 4.) When tool is not in use; 5.) When moving to a different work area, as accidental actuation may occur, possibly causing injury

LOADING TOOL

WARNING When loading tool:

- 1.) Never place a hand or any part of body in fastener discharge area of tool;
- 2.) Never point tool at anyone;
- 3.) Do not pull the trigger or depress the trip as accidental actuation may occur, possibly causing injury.

OPERATION

WARNING

- Always handle the tool with care: 1.) Never engage in horseplay; 2.) Never pull the trigger unless nose is directed toward the work; 3.) Keep others a safe distance from the tool while tool is in operation as accidental actuation may occur, possibly causing injury.
- The operator must not hold the trigger pulled on contact arm tools except during fastening operation as serious injury could result if the trip accidentally contacted someone or something, causing the tool to cycle.
- Keep hands and body away from the discharge area of the tool. A contact arm tool may bounce from the recoil of driving a fastener and an unwanted second fastener may be driven possibly causing injury.

- Check operation of the contact arm mechanism frequently. Do not use the tool if the arm is not working correctly as accidental driving of a fastener may result. Do not interfere with the proper operation of the contact arm mechanism.
- Do not drive fasteners on top of other fasteners or with the tool at an overly steep angle as this may cause deflection of fasteners which could cause injury.
- Do not drive fasteners close to the edge of the work piece as the wood may split, allowing the fastener to be deflected possibly causing injury

MAINTAINING THE TOOL

WARNING When working on air tools note the warnings in this manual and use extra care when evaluating problem tools.

Warning

This content is compiled from multiple sources and is provided for reference purposes only. It may not be complete or fully applicable to all situations. If you are unable to resolve your issue, please contact the product manufacturer or an authorized service provider for official support.