

PRODUCT OVERVIEW

Product Features

The images in this guide may be different from the actual components and accessories, which are subject to change by the manufacturer without prior notice for product improvement purposes.

Exterior

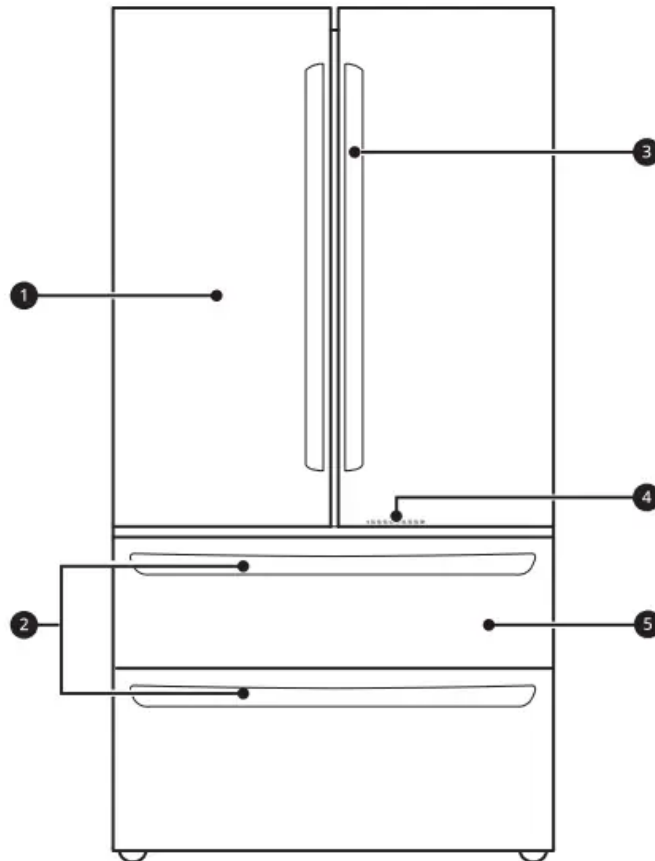

1. **Refrigerator:** Fresh food compartment
2. **Freezer Handle:** Opens the freezer drawer.
3. **Refrigerator Handle:** Opens and closes the refrigerator door.
4. **LED Light:** Lights up when the freezer door is opened.
5. **Freezer:** Frozen food compartment

Interior

LMWS27626*

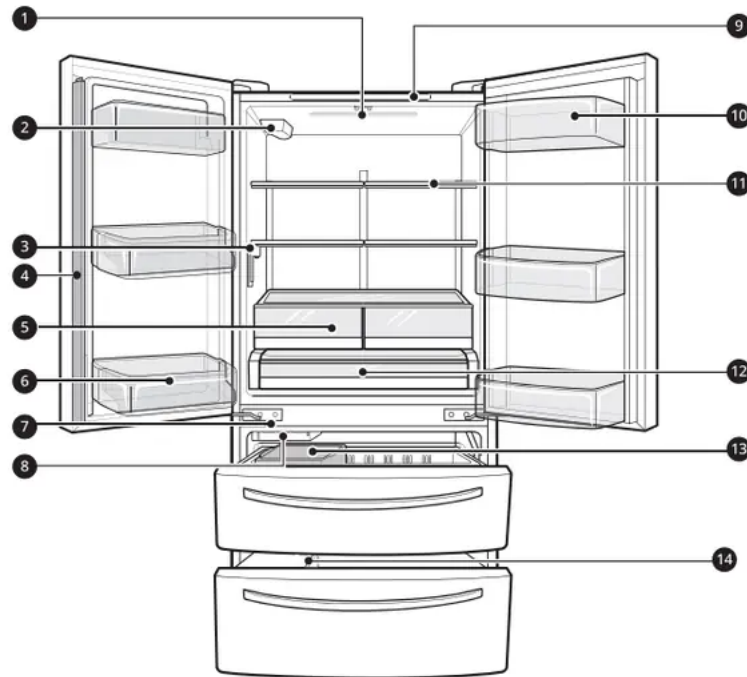

1. **LED Interior Lighting:** Lights up the inside of the refrigerator.
2. **Water Filter:** Purifies water.
3. **Water Dispenser:** Dispenses purified water.
4. **Door Mullion:** Prevents the cold air in the refrigerator from escaping when the doors are closed.
5. **Humidity Controlled Crisper:** Helps vegetables and fruit to stay crisp and controls humidity.
6. **Fixed Door Bin:** Stores chilled food or drinks.
7. **Auto-Closing Hinge:** The refrigerator doors and freezer drawers close automatically when pushed slightly. (The door only closes automatically when it is open at an angle of less than 30°.)
8. **Automatic Icemaker (Freezer):** Dispenses ice automatically.
9. **Control Panel:** Sets the refrigerator and freezer temperatures.
10. **Modular Door Bin:** Interchangeable bins can be arranged to suit storage needs.
11. **Adjustable Refrigerator Shelf:** The refrigerator shelves are adjustable to meet individual storage needs.
12. **Glide'N'Serve:** Stores food items at a different temperature than the regular refrigerator area.
13. **Ice Bin:** Stores ice from the freezer icemaker.

14. **Durabase and Durabase Divider:** Provides storage for large frozen food items.

Product Specifications

The appearance and specifications listed in this manual may vary due to constant product improvements.

- Electrical requirements: 115 V, 60 Hz
- Min. / Max. water pressure: 20 - 120 psi (138 - 827 kPa)

Model LMWS27626*	
Description	Standard-depth, French door refrigerator, bottom freezer
Net weight	291 lb (132 kg)

OPERATION

Before Use

Checklist

Clean the refrigerator.

Clean the refrigerator thoroughly and wipe off all dust that accumulated during shipping.

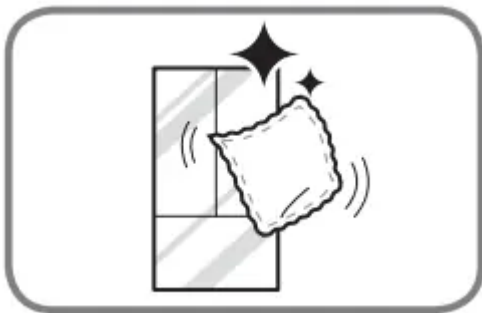

CAUTION

- Do not scratch the refrigerator with a sharp object or use a detergent that contains alcohol, a flammable liquid or an abrasive when removing any tape or adhesive from the refrigerator. Remove adhesive residue by wiping it off with your thumb or dish detergent.

- Do not peel off the model or serial number label or the technical information on the rear surface of the refrigerator.

Open refrigerator doors and freezer drawers to ventilate the interior.

The inside of the refrigerator may smell like plastic at first. Remove any adhesive tape from inside the refrigerator and open the refrigerator doors and the freezer drawers for ventilation.

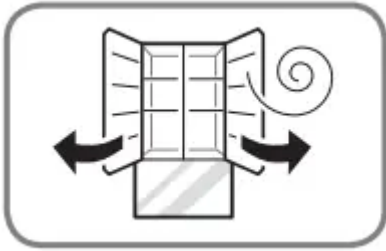

Connect the power supply.

Check if the power supply is connected before use.

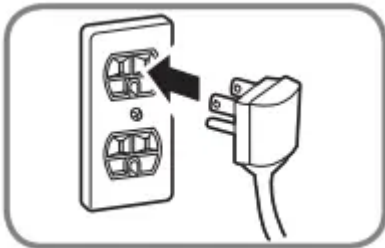

Turn off the icemaker.

Turn off the icemaker if the refrigerator is not yet connected to the water supply.

NOTE

- The icemaker water valve may buzz if the icemaker is turned on while the refrigerator is not connected to the water supply.

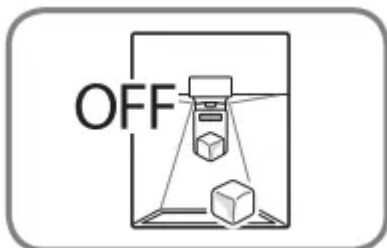

Wait for the refrigerator to cool.

Allow the refrigerator to run for at least two to three hours before putting food in it. Check the flow of cold air in the freezer compartment to ensure proper cooling.



CAUTION

- Putting food in the refrigerator before it has cooled could cause the food to spoil, or a bad odor to remain inside the refrigerator.

The refrigerator makes a loud noise after initial operation.

This is normal. The volume will decrease as the temperature decreases.



Control Panel

Depending on the model, some of the following functions may not be available. The actual control panel may differ from model to model.

Control Panel Features

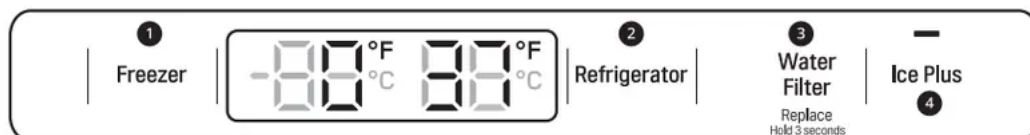

1. **Freezer:** Indicates the set temperature of the freezer compartment in Celsius (°C) or Fahrenheit (°F). The default freezer temperature is 0°F (-18 °C). Press the Freezer button repeatedly to select a new set temperature from - 7 °F to 5 °F (-23 °C to -15 °C).
2. **Refrigerator:** Indicates the set temperature of the refrigerator compartment in Celsius (°C) or Fahrenheit (°F). The default refrigerator temperature is 37 °F (3 °C). Press the

Refrigerator button repeatedly to select a new set temperature from 33 °F to 43 °F (1 °C to 7 °C).

NOTE

- To change the temperature mode from °F to °C (or vice versa) press and hold the Refrigerator and Freezer buttons simultaneously for approximately five seconds. The temperature indicator on the display window switches between Celsius and Fahrenheit.
 - The displayed temperature is the target temperature, and not the actual temperature of the refrigerator. The actual refrigerator temperature depends on the food inside the refrigerator.
3. **Water Filter:** Replace the water filter when the h icon turns on. After replacing the water filter, press and hold the Water Filter button for three seconds to turn the icon light off. Replace the water filter approximately every six months.
4. **Ice Plus:** This function increases both ice making and freezing capabilities. Press the Ice Plus button to illuminate the icon and activate the function for 24 hours. The function automatically shuts off after 24 hours. Stop the function manually by pressing the button once more.

CAUTION: Display Mode (For Store Use Only)

- The Display Mode disables all cooling in the refrigerator and freezer sections to conserve energy while on display in a retail store. When activated, OFF is displayed on the control panel and the display remains on for 20 seconds.
- To deactivate / activate:
 - With either refrigerator door opened, press the Ice Plus button 3 times consecutively while pressing the Refrigerator button. The control panel beeps and the temperature settings display to confirm that Display Mode is deactivated. Use the same procedure to activate Display Mode.

NOTE

- When the refrigerator is in the Power Saving Mode, the display remains off until a door is opened or a button is pressed. Once on, the display remains on for 20 seconds.

Sabbath Mode

Using the Sabbath Mode

Sabbath mode is used on the Jewish Sabbath and holidays.

- To turn Sabbath mode on, touch the display to activate it, then press and hold the Freezer and Water Filter buttons for 3 seconds until sb appears in the display.
- To turn Sabbath mode off manually, press and hold the Freezer and Water Filter buttons for 3 seconds.

NOTE

- Sabbath mode automatically turns off after 96 hours.
- Once turned on, Sabbath mode is maintained even after a power outage.
- Selecting Sabbath mode automatically turns off the Alarm functions.
- The dispenser or InstaView is disabled in Sabbath Mode. This information is only available on models with the dispenser or InstaView.

Water Dispenser

Before Using the Water Dispenser

CAUTION

- Keep children away from the dispenser. Children may play with or damage the controls.
- If water dispenses unexpectedly, turn off the water supply and contact an LG Electronics Customer Information Center.
- Never use a glass that is exceptionally narrow or deep.

NOTE

- The first water dispensed may include particles or odor from the water supply line or the water tank. This is also necessary if the refrigerator has not been used for a long time.
- Some dripping may occur after dispensing. Hold the cup beneath the dispenser for a few seconds after dispensing to catch all of the drops.
- Keep containers at an appropriate distance from the dispenser. A container with a very small opening should be held as close to the dispenser as possible to avoid spilling.

Using the Water Dispenser

Press the dispenser paddle **1** with a glass or other container to dispense water.

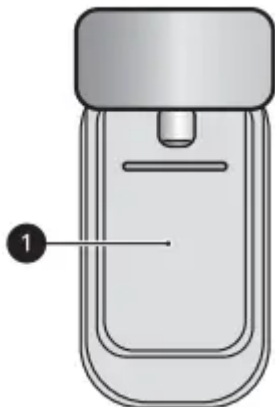

Automatic Icemaker

Before Using the Freezer Icemaker

This feature is only available on some models.

The feature may vary depending on model purchased.

NOTE

- Throw away the first few batches of ice (about 140 - 160 cubes) after installation. This is also necessary if the refrigerator has not been used for a long time.
- The icemaker begins producing ice approximately 48 hours after the appliance is initially installed.
- The sound of ice dropping into the ice bin is normal.
- If the ice bin is completely filled with ice, ice production will stop.
- The amount and shape of ice may vary according to the environment (ambient temperature around the appliance, frequency of the door being opened, amount of food stored in the appliance, water pressure, etc.).

NOTE • In the event of a power outage, throw away the ice stored in the ice bin.

Freezer Icemaker (Cubed Ice)

This feature is only available on some models.

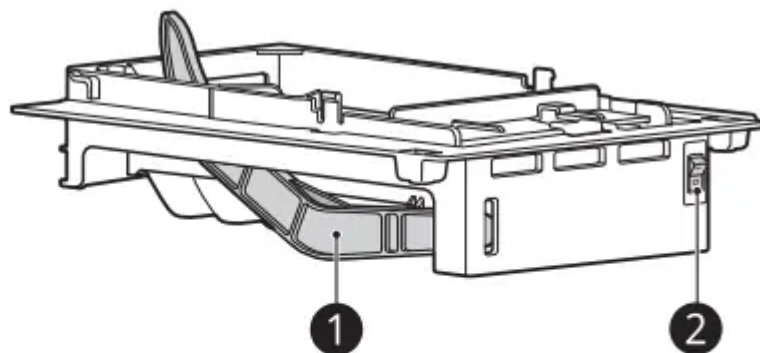

① Feeler Arm

② Power Switch

NOTE

- This automatic freezer icemaker produces 12 cubes at a time, 50-110 pieces within a 24 hour period if conditions are favorable. This amount may vary according to the environment

(ambient temperature around the appliance, frequency of the door being opened, amount of food stored in the appliance, etc.).

- Ice cubes which are stored in the ice bin for a long time may clump together and be difficult to separate. If this happens, empty the ice bin completely and clean it before reinstalling it.

Turning the Icemaker On/Off

To turn the automatic icemaker On/Off, press the power switch on the icemaker to the ON (|) or OFF (O) position.

Normal Sounds You May Hear

- Keeping the power turned on to the icemaker before the water line is connected can damage the icemaker.
- The icemaker water valve buzzes as the icemaker fills with water. If the icemaker power button is in the ON mode, it will buzz even if it has not yet been hooked up to water. To stop the buzzing, press the icemaker power button to turn it off.
- You will hear the sound of cubes dropping into the bin and water running in the pipes as the icemaker refills.

Preparing for Vacation

Set the icemaker power button to OFF and shut off the water supply to the refrigerator.

NOTE • The ice bin should be emptied any time the icemaker power button is turned to the OFF mode.

If the ambient temperature will drop below freezing, have a qualified technician drain the water supply system to prevent serious property damage due to flooding caused by ruptured water lines or connections.

Storing Food

Food Storage Tips

Wrap or store food in the refrigerator in airtight and moisture-proof material unless otherwise noted. This prevents food odor and taste transfer throughout the refrigerator. For dated products, check date code to ensure freshness.

CAUTION

- Do not overfill or pack items too tightly into door bins. Doing so may cause damage to the bin or personal injury if items are removed with excessive force.

- Do not store glass containers in the freezer. Contents may expand when frozen, break the container and cause injury.

Food	How to Store
Butter or Margarine	Keep opened butter in covered dish or closed compartment. When storing an extra supply, wrap in freezer packaging and freeze.
Cheese	Store in original wrapping until used. Once opened, rewrap tightly in plastic wrap or aluminum foil.
Milk	Wipe milk cartons. For coldest milk, place containers on an interior shelf.
Eggs	Store in original carton on interior shelf, not on door shelf.
Fruit	Do not wash or hull fruit until it is ready to be used. Sort and keep fruit in original container in a crisper, or store in completely closed paper bag on refrigerator shelf.
Leafy Vegetables	Remove store wrapping, trim or tear off bruised and discolored areas, wash in cold water, and drain. Place in plastic bag or plastic container and store in crisper.
Vegetables with skins (carrots, peppers)	Place in plastic bags or plastic container and store in crisper.
Fish	Freeze fresh fish and shellfish if they are not being eaten the same day purchased. Eating fresh fish and shellfish the same day purchased is recommended.
Leftovers	



Food	How to Store
	Cover leftovers with plastic wrap or aluminum foil, or store in plastic containers with tight lids.

Storing Frozen Food

Check a freezer guide or a reliable cookbook for further information about preparing food for freezing or food storage times.

Freezing

Your freezer will not quick-freeze a large quantity of food. Do not put more unfrozen food into the freezer than will freeze within 24 hours (no more than 2 to 3 pounds of food per cubic foot of freezer space). Leave enough space in the freezer for air to circulate around packages. Be careful to leave enough room at the front so the door can close tightly.

Storage times will vary according to the quality and type of food, the type of packaging or wrap used (how airtight and moisture-proof) and the storage temperature. Ice crystals inside a sealed package are normal. This simply means that moisture in the food and air inside the package have condensed, creating ice crystals.

NOTE • Allow hot foods to cool at room temperature for 30 minutes, and then package and freeze. Cooling hot foods before freezing saves energy.

Packaging

Successful freezing depends on correct packaging. When you close and seal the package, it must not allow air or moisture in or out. If it does, you could have food odor and taste transfer throughout the refrigerator and could also dry out frozen food.

Packaging recommendations

- Rigid plastic containers with tight-fitting lids
- Straight-sided canning/freezing jars
- Heavy-duty aluminum foil
- Plastic-coated paper
- Non-permeable plastic wraps
- Specified freezer-grade self-sealing plastic bags

Follow package or container instructions for proper freezing methods.

Do not use

- Bread wrappers
- Non-polyethylene plastic containers
- Containers without tight lids
- Wax paper or wax-coated freezer wrap
- Thin, semi-permeable wrap

NOTE

- If you are leaving home for a short period, like a short vacation, the refrigerator should be left on. Refrigerated foods that are able to be frozen will stay preserved longer if stored in the freezer.
- If you are leaving the refrigerator turned off for an extended period, remove all food and unplug the power cord. Clean the interior, and leave the door open to prevent fungi from growing in the refrigerator.
- Do not store food with high moisture content towards the top of the refrigerator. The moisture could come in direct contact with the cold air and freeze.
- Wash food before storing it in the refrigerator. Vegetables should be washed, and food packaging should be wiped down to prevent adjacent foods from being contaminated.
- If the refrigerator is kept in a hot and humid place, frequent opening of the door or storing a lot of vegetables in the refrigerator may cause condensation to form. Wipe off the condensation with a clean cloth or a paper towel.
- If the refrigerator door or freezer drawer is opened or closed too often, warm air may penetrate the refrigerator and raise its temperature. This can increase the running costs of the unit.

Humidity Controlled Crispers

Using the Humidity Controlled Crispers

This feature is only available on some models.

The crispers provide fresher tasting fruit and vegetables by letting you easily control humidity inside the drawer.

You can control the amount of humidity in the moisture-sealed crispers by adjusting the control to any setting between Vegetables and Fruit.

- Vegetables keeps moist air in the crisper for best storage of fresh, leafy vegetables.
- Fruit lets moist air out of the crisper for best storage of fruit.

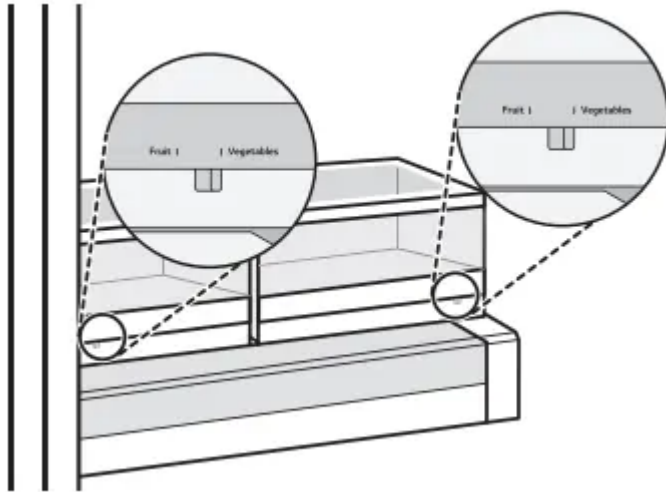

Removing/Assembling the Humidity Controlled Crispers

1. Open the doors completely and remove the contents of the Door-in-Door case. Lift up and pull out the Door-in-Door case.

NOTE • The Door-in-Door feature is only available on some models.

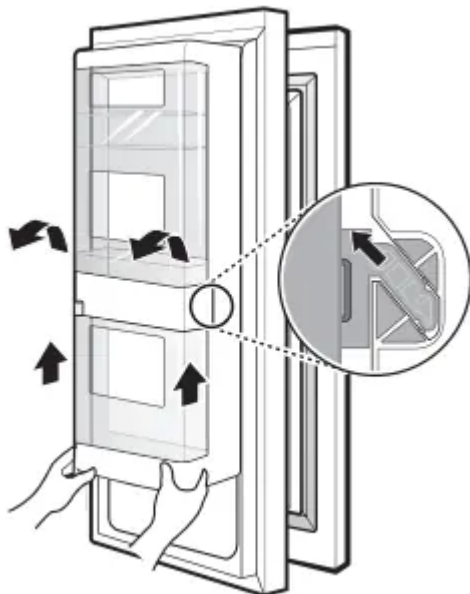

2. Pull out the crisper to full extension, lift the front up, and pull straight out.

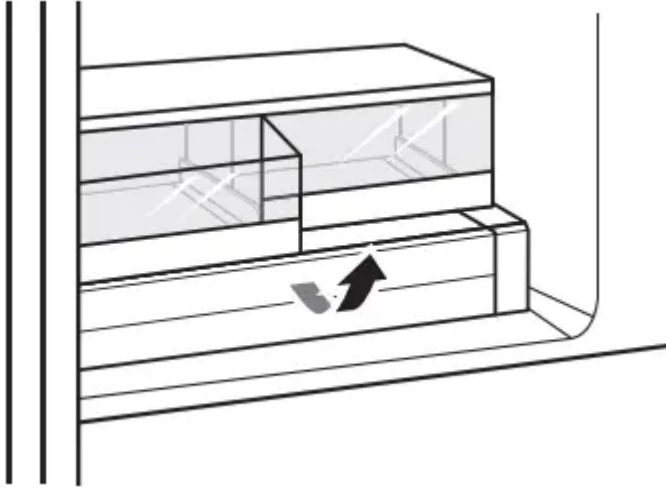

3. Lift the front of the cover up with both hands until it detaches from the back wall of the cabinet, then pull it out.

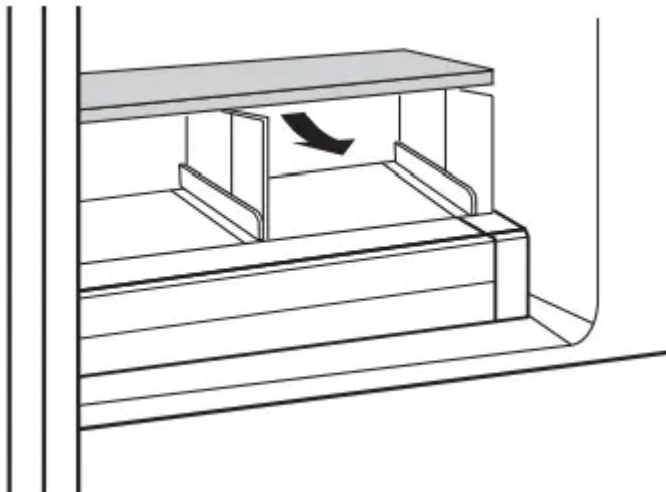

4. To reassemble, insert the cover into the refrigerator with both hands and lower it onto the guides.

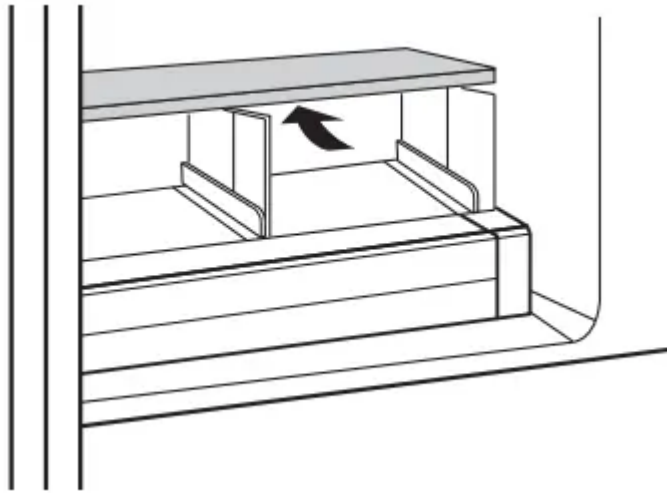

5. Slightly tilt up the front, insert the crisper into the frame and push it back into place.

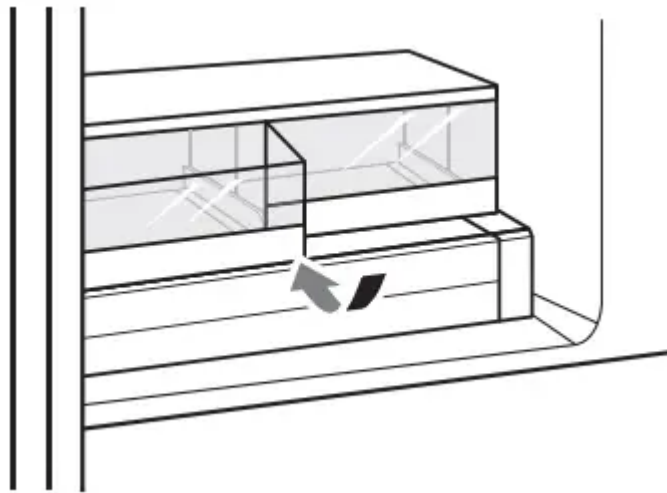

6. Line up the tabs on the Door-in-Door case with the slots on the door and push down until it snaps into place.

NOTE • The Door-in-Door feature is only available on some models.

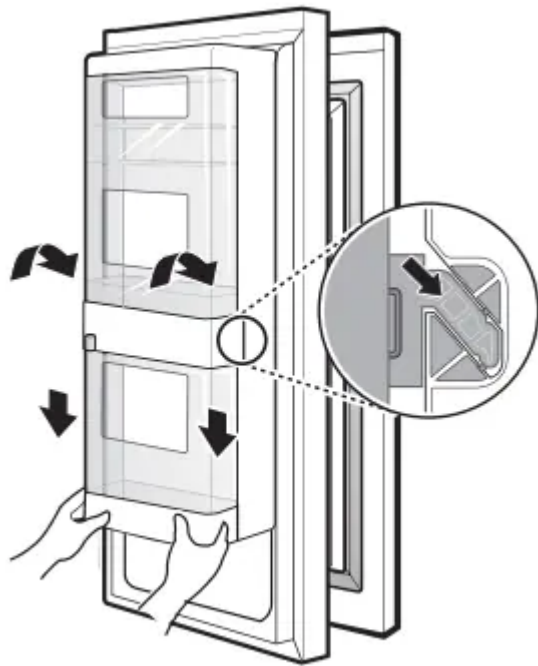

Glide'N'Serve

Using the Glide'N'Serve

This drawer can be used for large party trays, deli items and beverages. This drawer should not be used to store vegetables that require high humidity.

CAUTION • Do not place any items on the Glide'N'Serve cover.

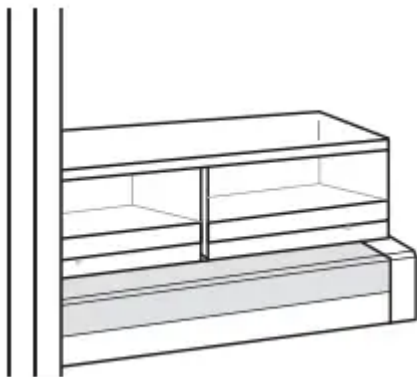

Detaching/Assembling the Glide'N'Serve

1. To remove the Glide'N'Serve, pull out the Glide'N'Serve to full extension, lift the front up, and pull straight out.

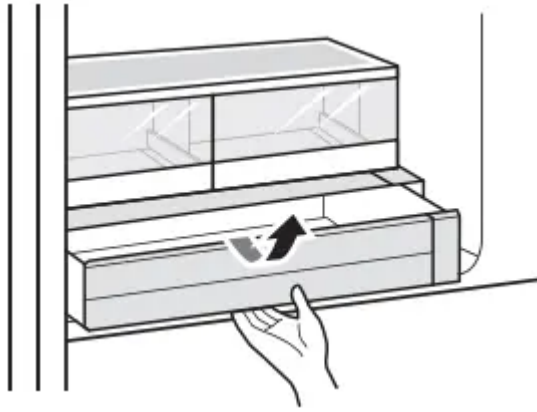

2. To assemble, slightly tilt up the front, insert the Glide'N'Serve into the frame and push it back into place.

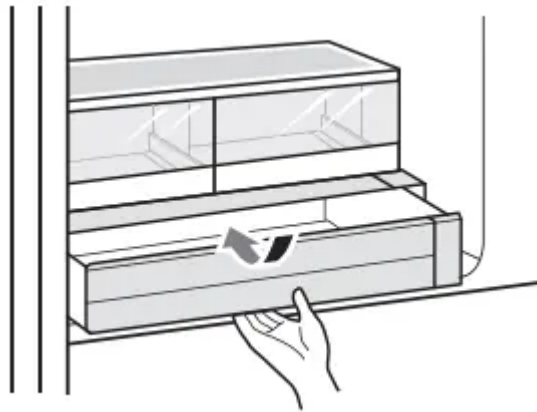

Refrigerator Shelves

The shelves in the refrigerator are adjustable to meet individual storage needs. Your model may have full or split shelves.

Adjusting the shelves to fit items of different heights will make finding the exact item you want easier.

Detaching/Assembling the Half Width Shelf

CAUTION • Do not clean glass shelves with warm water while they are cold. Shelves may break if exposed to sudden temperature changes or impact.

1. To detach, tilt up the front of the shelf and lift the shelf straight up.
2. Pull the shelf out.

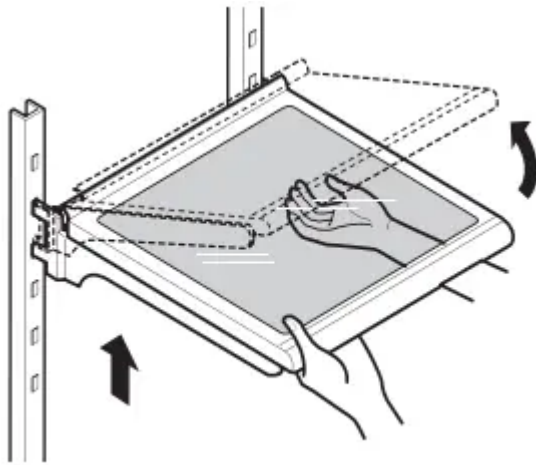

3. To assemble, tilt the front of the shelf up and guide the shelf hooks into the slots at a desired height.

4. Lower the front of the shelf so that the hooks drop into the slots.

CAUTION • Make sure that shelves are level from one side to the other. Failure to do so may result in the shelf falling or spilled food.

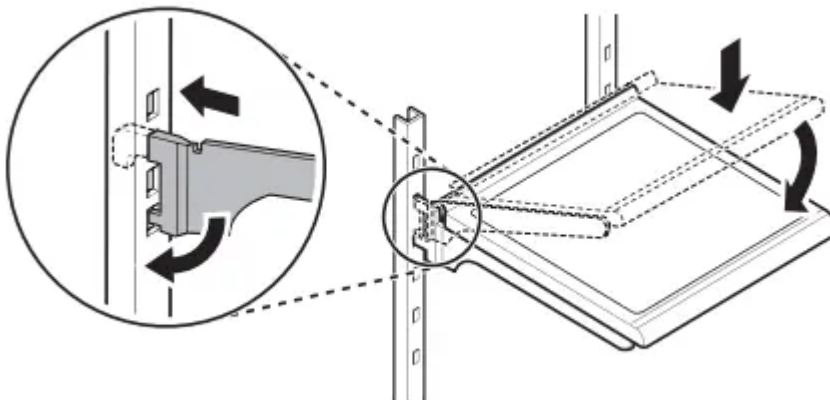

Door Bins

Detaching/Refitting the Door Bin

The door bins are removable for easy cleaning and adjustment.

1. To remove the bin, simply lift the bin up and pull straight out.

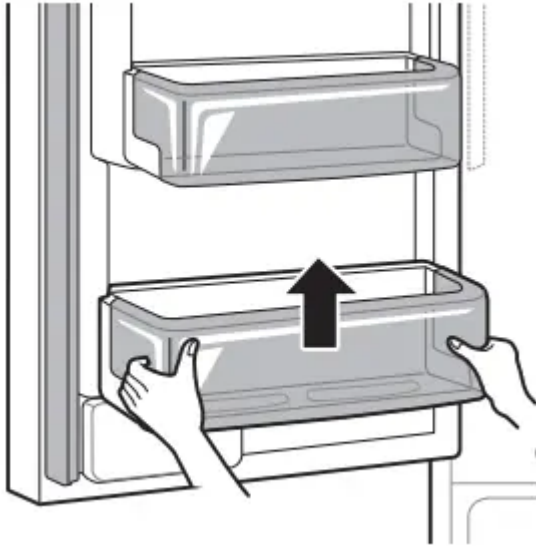

2. To replace the bin, slide it in above the desired support and push down until it snaps into place.

CAUTION

- Regularly detach and wash the storage bins and shelves; they can become easily contaminated by food.
- Do not apply excessive force while detaching or assembling the storage bins.
- Do not use the dishwasher to clean the storage bins and shelves.

Durabase

Using the Durabase

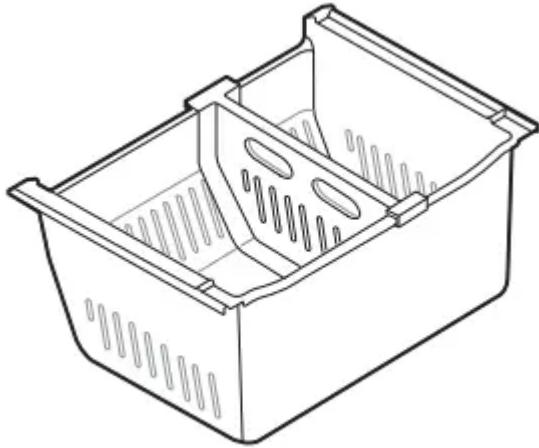

CAUTION • If the Durabase divider is removed, there is enough open space for children or pets to crawl inside. To prevent accidental child and pet entrapment or suffocation risk, **DO NOT** allow children or pets to touch or go near the drawer.

The Durabase divider allows you to organize the Durabase area into 2 sections. It can be adjusted from side to side to accommodate items of different sizes.



SMART FUNCTIONS

LG ThinQ Application

This feature is only available on models with the  or  logo.

The LG ThinQ application allows you to communicate with the appliance using a smartphone.

Installing the LG ThinQ Application



Search for the LG ThinQ application from the Google Play Store or Apple App Store on a smart phone. Follow instructions to download and install the application.

LG ThinQ Application Feature

Smart Diagnosis

If you experience a problem while using the appliance, this smart diagnosis feature will help you diagnose the problem.

Smart Diagnosis™ Feature

This feature is only available on models with the  or  logo.

Use this feature to help you diagnose and solve problems with your appliance.

NOTE

- For reasons not attributable to LGE's negligence, the service may not operate due to external factors such as, but not limited to, Wi-Fi unavailability, Wi-Fi disconnection, local app store policy, or app unavailability.

- The feature may be subject to change without prior notice and may have a different form depending on where you are located.

Using Audible Diagnosis to Diagnose Issues

Follow the instructions below to use the audible diagnosis method.

- Launch the LG ThinQ application and select the Smart Diagnosis feature in the menu. Follow the instructions for audible diagnosis provided in the LG ThinQ application.

1. Open the right refrigerator door.
2. Hold the mouthpiece of your phone in front of the speaker that is located on the right hinge of the refrigerator door.

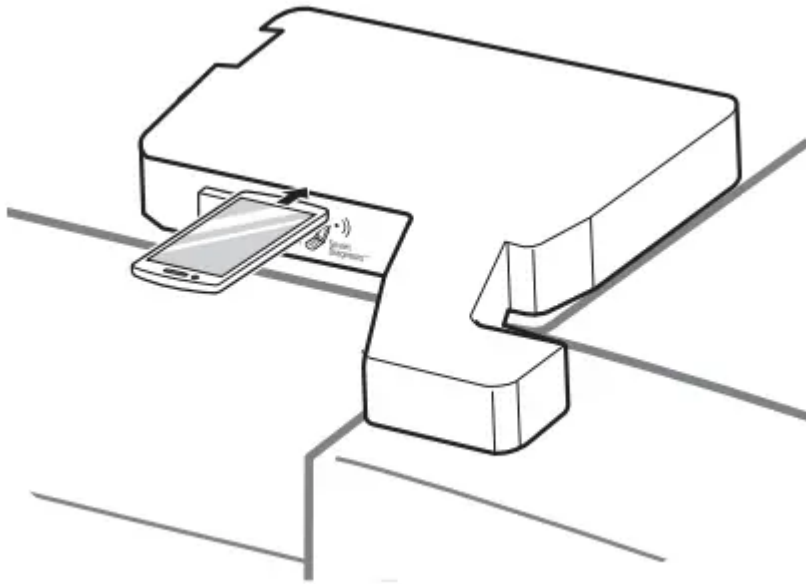

3. Press and hold the Freezer button for three seconds while continuing to hold your phone to the speaker.



4. After you hear three beeps, release the Freezer button.

5. Keep the phone in place until the tone transmission has finished. The display will count down the time. Once the countdown is over and the tones have stopped, the diagnosis will be displayed in the application.

NOTE • For best results, do not move the phone while the tones are being transmitted.

MAINTENANCE

Cleaning

WARNING • Use non-flammable cleaner. Failure to do so can result in fire, explosion, or death.

CAUTION

- Do not use an abrasive cloth or sponge when cleaning the interior and exterior of the refrigerator.
- Do not place your hand on the bottom surface of the refrigerator when opening and closing the doors.

General Cleaning Tips

- Both the refrigerator and freezer sections defrost automatically; however, clean both sections once a month to prevent odors.
- Wipe up spills immediately.
- Unplug the refrigerator or disconnect power before cleaning.
- Remove all removable parts, such as shelves.
- Use a clean sponge or soft cloth and a mild detergent in warm water. Do not use abrasive or harsh cleaners.
- Hand wash, rinse and dry all surfaces thoroughly.

Exterior

Waxing external painted metal surfaces helps provide rust protection. Do not wax plastic parts. Wax painted metal surfaces at least twice a year using appliance wax (or auto paste wax). Apply wax with a clean, soft cloth.

For products with black stainless steel exterior, spray glass cleaner on a clean, microfiber cloth and rub in direction of grain. Do not spray glass cleaner directly at the display panel. Do not use harsh or abrasive cleaners.

For products with a standard stainless steel exterior, use a damp microfiber cloth and rub in the direction of the grain. Dry with a paper towel to avoid streaks. For stubborn stains and

fingerprints, use a few drops of liquid dish soap in water, and rinse with hot water before drying. Do not use abrasive or harsh cleaners.

Inside Walls

- Allow freezer to warm up so the cloth will not stick.

To help remove odors, wash the inside of the refrigerator with a mixture of baking soda and warm water. Mix 2 tablespoons of baking soda to 1 quart of water (26 g soda to 1 liter water.) Be sure the baking soda is completely dissolved so it does not scratch the surfaces of the refrigerator.

Door Liners and Gaskets

Use a clean sponge or soft cloth and a mild detergent in warm water. Do not use cleaning waxes, concentrated detergents, bleaches, or cleaners containing petroleum on plastic refrigerator parts.

Plastic Parts (Covers and Panels)

Use a clean sponge or soft cloth and a mild detergent in warm water. Do not use glass cleaners, abrasive cleansers, or flammable fluids. These can scratch or damage the material.

Condenser Coils

Use a vacuum cleaner with a brush or crevice attachment to clean the condenser cover and vents. Do not remove the panel covering the condenser coil area.

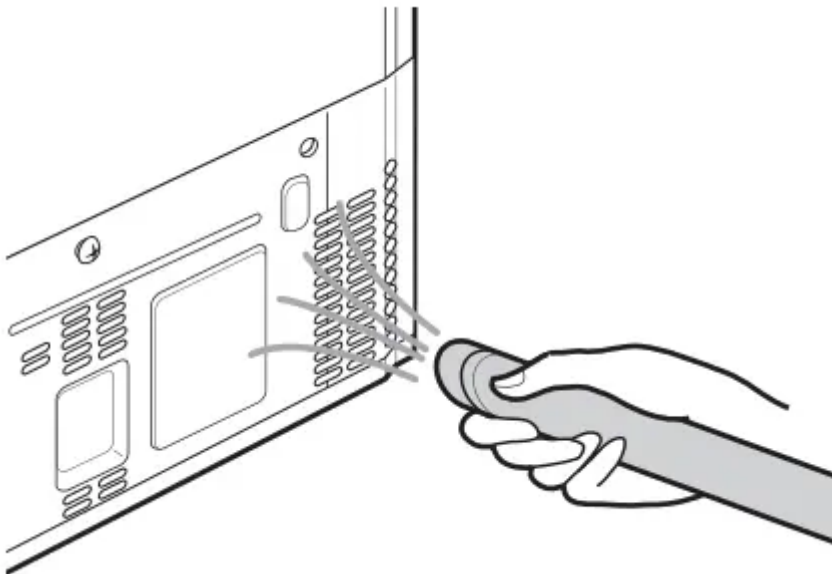

Water Filter

Replacing the Water Filter

Replace the water filter:

- Approximately every six months.
- When the water dispenser output decreases.

To purchase a replacement water filter:

- Visit your local dealer or distributor
- Search using "water filter" on lg.com
- Use replacement cartridge: LT1000P, LT1000PC or LT1000PCS

1. If the top shelf, located below the water filter, is in the highest position, it will need to be removed prior to replacing the water filter.

- To remove any shelf, tilt up the front of the shelf and lift it. Pull the shelf out.

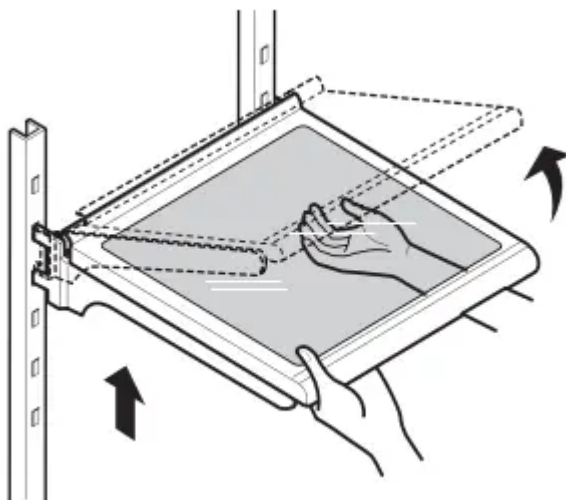

2. Pinch the sides to open the water filter cover.



3. Pull the water filter downward and turn it counterclockwise before pulling it out.

- Make sure to rotate the filter down completely before pulling it out of the manifold hole.

NOTE

- Replacing the water filter causes a small amount of water (around 1 oz. or 25 cc) to drain.
- Wrap a cloth around the front end of the water filter cover to collect any leaking water. Hold the water filter upright, once it is removed, to prevent any remaining water from spilling out of the water filter.

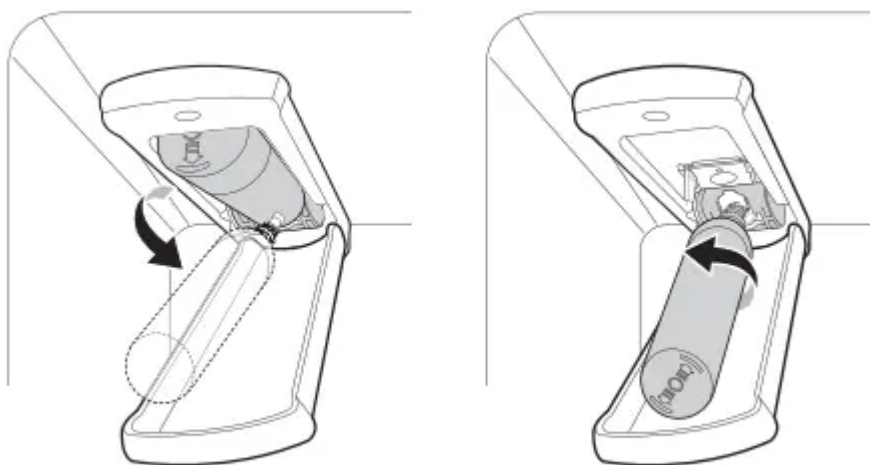

4. Replace with a new water filter.

- Take the new water filter out of its packing and remove the protective cover from the orings. With the water filter tabs in the horizontal position, push the new water filter into the manifold hole and turn it clockwise until it stops.

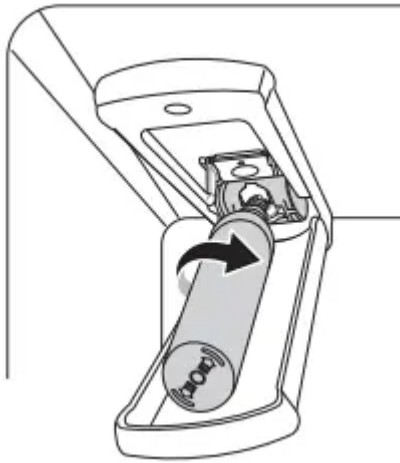

5. Close the water filter cover. The cover will click when closed correctly.



6. After the water filter is replaced, dispense 2.5 gallons of water (flush for approximately 5 minutes) to remove trapped air and contaminants from the system.

NOTE

- Do not dispense the entire 2.5 gallon amount continuously. Press and release the dispenser pad for cycles of 30 seconds ON and 60 seconds OFF.

7. After changing the filter, press and hold the Water Filter button for three seconds to reset the indicator light.



CAUTION



- LG strongly recommends that you use LG authorized water filters to prevent water quality issues, water leakage and appliance malfunction.

TROUBLESHOOTING

FAQs

Frequently Asked Questions

Q: What are the best temperature settings for my refrigerator and freezer?

A: The default setting for the refrigerator is 37° Fahrenheit (3° Celsius). The default setting for the freezer is 0° Fahrenheit (-18° Celsius). Adjust these settings as necessary to keep food at desired temperatures. Milk should be cold when stored on the inner shelf of the refrigerator. Ice cream should be firm and ice cubes should not melt in the freezer. To switch the display from Fahrenheit to Celsius, press and hold the **Freezer** and **Refrigerator** buttons until you hear a beep and the settings in the display change.

Q: How do I set the refrigerator and freezer temperatures?

A: Continually press the **Refrigerator** or **Freezer** button on the control panel until the desired temperature appears. The numbers will cycle from highest to lowest and then return to the highest again with continuous pressing.

Q: Why do I hear a buzzing noise from my refrigerator periodically?

A: This may happen if you do not have a water source attached to your refrigerator and the icemaker is turned on. If you do not have a water source attached to the back of the refrigerator you should turn the icemaker off.

Q: Why does the icemaker tray look crooked?

A: This is a normal part of the icemaker cycle. The icemaker tray may appear level or with a slight tilt. The change in position is to assist in the freezing process.

Q: My refrigerator is powered on and the controls are working, but it's not cooling and the display shows "OFF" (see below). What is wrong?

A: The refrigerator is in Display Mode. The Display Mode disables all cooling in the refrigerator and freezer sections to conserve energy while on display in a retail store. When activated, OFF is displayed on the control panel and the display remains on for 20 seconds. With either refrigerator door opened, press the **Ice Plus** button 3 times consecutively while pressing the **Refrigerator** button. The control panel beeps and the temperature settings display to confirm that Display Mode is deactivated. Use the same procedure to activate Display Mode.



Before Calling for Service

Review this section before calling for service; doing so will save you both time and money.

Cooling

Problem	Possible Cause & Solution
Refrigerator and Freezer section are not cooling.	<p>The refrigerator control is set to OFF (some models).</p> <ul style="list-style-type: none"> • Turn the control ON. Refer to the Setting the Controls section for proper temperature settings.
	<p>Refrigerator is set to Demo Mode.</p> <ul style="list-style-type: none"> • Demo Mode allows the lights and control display to work normally while disabling cooling, to save energy while the refrigerator is on the showroom floor. See the FAQs section of this manual for instructions on how to disable Demo Mode.
	<p>Refrigerator is in the defrost cycle.</p> <ul style="list-style-type: none"> • During the defrost cycle, the temperature of each compartment may rise slightly. Wait 30 minutes and confirm the proper temperature has been restored once the defrost cycle has completed.
	<p>Refrigerator was recently installed.</p> <ul style="list-style-type: none"> • It may take up to 24 hours for each compartment to reach the desired temperature.
	<p>Refrigerator was recently relocated.</p> <ul style="list-style-type: none"> • If the refrigerator was stored for a long period of time or moved on its side, it is necessary for the refrigerator to stand upright for 24 hours before connecting it to power.
	<p>Refrigerator is replacing an older model.</p>

Problem	Possible Cause & Solution
<p>Cooling system runs too much.</p>	<ul style="list-style-type: none"> • Modern refrigerators require more operating time but use less energy due to more efficient technology.
	<p>Refrigerator was recently plugged in or power restored.</p> <ul style="list-style-type: none"> • The refrigerator will take up to 24 hours to cool completely.
	<p>The door is opened often or a large amount of food / hot food was added.</p> <ul style="list-style-type: none"> • Adding food and opening the door warms the refrigerator, requiring the compressor to run longer in order to cool the refrigerator back down. In order to conserve energy, try to get everything you need out of the refrigerator at once, keep food organized so it is easy to find, and close the door as soon as the food is removed. (Refer to the Food Storage Guide.)
	<p>Doors are not closed completely.</p> <ul style="list-style-type: none"> • Firmly push the doors shut. If they will not shut all the way, the "Doors will not close correctly or pop open" section in Troubleshooting.
	<p>Refrigerator is installed in a hot location.</p> <ul style="list-style-type: none"> • The compressor will run longer under warm conditions. At normal room temperatures (70°F or 21°C) expect your compressor to run about 40 % to 80 % of the time. Under warmer conditions, expect it to run even more often. The refrigerator should not be operated above 110°F (43°C).
	<p>Condenser / back cover is clogged.</p> <ul style="list-style-type: none"> • Use a vacuum cleaner with an attachment to clean the condenser cover and vents. Do not remove the panel covering the condenser coil area.
<p>Interior moisture buildup.</p>	<p>Doors are opened often or for long periods of time.</p> <ul style="list-style-type: none"> • When the doors are opened often or for long periods of time, warm, humid air enters the compartment. This raises the temperature and



Problem	Possible Cause & Solution
Icemaker is not making enough ice.	<p>frequency and duration of door openings. Demand exceeds ice storage capacity.</p>
	<ul style="list-style-type: none"> The icemaker will produce approximately 70-184 cubes in a 24 hour period. <p>Doors are not closed correctly.</p> <ul style="list-style-type: none"> See the "Doors will not close correctly or pop open" section.
	<p>House water supply is not connected, valve is not turned on fully, or water is clogged.</p>
	<ul style="list-style-type: none"> Connect the refrigerator to a cold water supply with adequate pressure and turn the water shutoff valve fully open. If the problem persists, it may be necessary to contact a plumber. <p>maintaining a reasonable level of humidity in the home will help to control the amount of moisture that can enter the compartments.</p>
	<p>Water filter has been exhausted.</p> <p>Defrost cycle recently completed.</p> <ul style="list-style-type: none"> Replacing the water filter is recommended: During the defrost cycle, the temperature of each compartment may rise slightly and condensation may form on the back wall. Wait 30 minutes and confirm that the proper temperature has been restored once the defrost cycle is completed. <p>When the ice cubes are smaller than normal.</p>
	<p>Food is not packaged correctly.</p>
	<p>Low house water supply pressure.</p> <p>Low house water supply pressure, and damp containers can lead to moisture accumulation within each compartment. Wipe all containers dry and store food in sealed packaging to prevent condensation and frost.</p> <ul style="list-style-type: none"> The water pressure must be between 20 and 120 psi on models without a water filter and between 40 and 120 psi on models with a water filter. If the problem persists, it may be necessary to contact a plumber.
Food is freezing in the refrigerator compartment.	<p>Food with high water content was placed near an air vent.</p>
	<p>Reverse osmosis filtration system is used.</p> <p>Reverse osmosis filtration systems can reduce the water pressure.</p>
	<p>Refrigerator temperature control is set incorrectly.</p> <ul style="list-style-type: none"> Refrigerator temperature control is set incorrectly. (Refer to the Connecting the Water Line section.) If the temperature is too cold, adjust the control one increment at a time and wait for the temperature to stabilize. Refer to the Control Panel Setting section.
	<p>Tubing connecting refrigerator to house supply valve is kinked.</p>
	<ul style="list-style-type: none"> The tubing can kink when the refrigerator is moved during installation. <p>Refrigerator is installed in a cold location.</p> <ul style="list-style-type: none"> Straighten or repair the water supply line and arrange it to prevent future kinks.
<p>Problem</p>	<p>Possible Cause & Solution</p>
<p>making enough ice.</p>	<ul style="list-style-type: none"> The icemaker will produce approximately 70-184 cubes in a 24 hour



Problem	Possible Cause & Solution
	<ul style="list-style-type: none"> When the refrigerator is operated in temperature below 41°F (5°C), food can freeze in the refrigerator compartment. The refrigerator should not be operated in temperature below 55°F (13°C).
Refrigerator or Freezer section is too cold.	<p>Incorrect temperature control settings.</p> <ul style="list-style-type: none"> If the temperature is too cold, adjust the control one increment at a time and wait for the temperature to stabilize. Refer to the Control Panel for more information.
Frost or ice crystals form on frozen food (inside of sealed package).	<p>Condensation from food with a high water content has frozen inside of the food package.</p> <ul style="list-style-type: none"> This is normal for food items with a high water content.
	<p>Food has been left in the freezer for a long period of time.</p> <ul style="list-style-type: none"> Do not store food items with high water content in the freezer for a long period of time.
Frost or ice crystals form on frozen food (outside of package).	<p>Door is opened frequently or for long periods of time.</p> <ul style="list-style-type: none"> When the doors are opened often or for long periods of time, warm, humid air enters the compartment. This raises the temperature and moisture level within the compartment. Increased moisture will lead to frost and condensation. To lessen the effect, reduce the frequency and duration of door openings.
	<p>Door is not closing properly.</p> <ul style="list-style-type: none"> Refer to the "Doors will not close correctly or pop open" section in the Troubleshooting.
Refrigerator or Freezer section is too warm.	<p>Refrigerator was recently installed.</p> <ul style="list-style-type: none"> It may take up to 24 hours for each compartment to reach the desired temperature.
	<p>The air vents are blocked. Cold air circulates from the freezer to the fresh food section and back again through air vents in the wall dividing the two sections.</p>
Problem	Possible Cause & Solution
	<ul style="list-style-type: none"> If the doors of the unit are opened often, ambient air will warm the



Problem	Possible Cause & Solution
	<p>Air trapped by the water filter is causing the ice to warm and move all items that block vents and restrict airflow. Rearrange items to allow approximately every six months.</p> <p>When the water filter indicator turns on.</p> <p>Doors are opened often or for long periods of time.</p> <p>When the water dispenser output decreases.</p> <p>When the ice cubes are smaller than normal.</p> <p>the doors are opened often or for long periods of time, warm, air enters the compartment. This raises the temperature and the level within the compartment. To lessen the effect, reduce the frequency and duration of door openings.</p> <ul style="list-style-type: none"> Reverse osmosis filtration systems used. Reverse osmosis filtration systems can reduce the water pressure below the minimum amount and result in icemaker installed in the proper location. <p>If the problem persists, it may be necessary to contact a plumber.</p> <p>frigerator should not be operated in temperatures above 110 °F</p> <p>Low house water supply pressure.</p> <p>amount of food or hot food was added to either compartment.</p> <p>minimum water pressure must be between 20 and 20 psi on models without a water filter and between 40 and 120 psi on models with a water filter. If the problem persists, it may be necessary to contact a plumber.</p> <p>adding hot food to the compartment requiring the cooling system to bring not food to cool to room temperature before putting it in refrigerator will reduce this effect.</p>
<p>Water is not dispensing.</p>	<p>New installation or water line recently connected.</p> <p>Doors are not closed correctly.</p> <p>of water (flush for approximately 5 minutes) to remove trapped air and contaminants from the system. Do not dispense the entire 2.5 gallon amount continuously. Depress and release the dispenser pad for cycles of 30 seconds ON and 60 seconds OFF.</p> <p>Temperature control is not set correctly.</p> <ul style="list-style-type: none"> If the temperature is too warm, adjust the control one increment at a time and wait for the temperature to stabilize. Press and hold the Lock button for three seconds to unlock the control panel and dispenser. <p>Defrost cycle has recently completed.</p> <ul style="list-style-type: none"> During the defrost cycle, the temperature of each compartment may rise slightly and condensation may form on the back wall. Wait 30 minutes and confirm the proper temperature has been restored once the defrost cycle has completed. <p>The dispenser is not set for water dispensing.</p> <ul style="list-style-type: none"> The dispenser can be set for ice or water. Make certain that the control panel is set for the proper operation. Press the Water button on the control panel to dispense water.

Problem	Possible Cause & Solution
<p>Problem</p>	<p>Page 32 Possible Cause & Solution</p>



Problem	Possible Cause & Solution
<p>Icemaker is making too much ice.</p>	<p>Icemaker shutoff (arm/ sensor) is obstructed.</p> <ul style="list-style-type: none"> • Empty the ice bin. If your icemaker is equipped with an ice shutoff arm, make sure that the arm moves freely. If your icemaker is equipped with the electronic ice shutoff sensor, make sure that there is a clear path between the two sensors. Reinstall the ice bin and wait 24 hours to confirm proper operation.
<p>Ice is not dispensing.</p>	<p>Unable to hear the sound of ice coming out?</p> <ul style="list-style-type: none"> • In the control panel, select the modes for cubed ice and crushed ice alternately to dispense the ice.
	<p>Doors are not closed completely.</p> <ul style="list-style-type: none"> • Ice will not dispense if any of the refrigerator doors are left open.
	<p>Infrequent use of the dispenser.</p> <ul style="list-style-type: none"> • Infrequent use of the ice dispenser will cause the cubes to stick together over time, which will prevent them from properly dispensing. Check the ice bin for ice cubes clumping/ sticking together. If they are, break up the ice cubes to allow for proper operation.
	<p>The delivery chute is clogged with frost or ice fragments.</p> <ul style="list-style-type: none"> • Eliminate the frost or ice fragments by removing the ice bin and clearing the chute with a plastic utensil. Dispensing cubed ice can also help prevent frost or ice fragment buildup.
	<p>The dispenser display is locked.</p> <ul style="list-style-type: none"> • Press and hold the Lock button for three seconds to unlock the control panel and dispenser.
	<p>Ice bin is empty.</p> <ul style="list-style-type: none"> • It may take up to 24 hours for each compartment to reach the desired temperature and for the icemaker to begin making ice. Make sure that the shutoff (arm/sensor) is not obstructed. Once the ice supply in the bin has been completely exhausted, it may take up to 90 minutes before
<p>Problem</p>	<p>Possible Cause & Solution</p>



Problem	Possible Cause & Solution
	<p>and approximately 24 hours to completely</p> <ul style="list-style-type: none"> Rearrange food containers to clear the door and door shelves. <hr/> <p>Ice bin, crisper cover, pans, shelves, door bins, or baskets are out of position.</p> <ul style="list-style-type: none"> Push bins all the way in and put crisper cover, pans, shelves and baskets into their correct positions. See the Operation section for more information. <hr/> <p>Refrigerator is not connected to the hot water supply.</p> <p>The doors were removed during product installation and not properly replaced.</p> <p>Connecting the refrigerator to a hot water line may be required. Replacing Refrigerator Handles and Doors section.</p> <hr/> <p>Refrigerator contains minerals such as sulfur.</p> <p>Refrigerator is not leveled properly.</p> <p>Refrigerator may need to be installed to eliminate taste and odor.</p> <ul style="list-style-type: none"> See Door Alignment in the Refrigeration Installation section to level refrigerator.
<p>Doors are difficult to open.</p>	<p>Water filter has been exhausted.</p> <p>The gaskets are dirty or sticky.</p> <p>A water filter is recommended:</p> <ul style="list-style-type: none"> Clean the gaskets and the surfaces that they touch every six months. Rub a thin coat of appliance polish or kitchen wax on the gaskets after cleaning. <hr/> <p>Water dispenser output decreases.</p> <hr/> <p>Door was recently closed.</p> <p>When doors are closed, the air inside the refrigerator is warmer than normal.</p> <ul style="list-style-type: none"> When you open the door, warmer air enters the refrigerator. As the warm air cools, it can create a vacuum. If the door is hard to open, dispense 2 to 3 gallons of water (flush for approximately 5 minutes) to move trapped air and contaminants from the door. Wait one minute to allow the air pressure to equalize, then see if it opens more easily. If the door still does not dispense the entire 2.5 gallon amount, see the Troubleshooting section.
<p>Refrigerator wobbles or seems unstable</p>	<p>Depress and release the dispenser pad for 10 seconds. The dispenser pad will be depressed and the water will dispense.</p> <p>Leveling legs are not adjusted properly.</p> <ul style="list-style-type: none"> Refer to the Leveling and Door Alignment section.



Problem	Possible Cause & Solution
	<p>Floor is not level.</p> <ul style="list-style-type: none"> • It may be necessary to add shims under the leveling legs or rollers to complete installation.
<p>Lights do not work.</p>	<p>LED interior lighting failure.</p> <ul style="list-style-type: none"> • The refrigerator compartment lamp is LED interior lighting, and service should be performed by a qualified technician.
<p>Refrigerator has an unusual odor.</p>	<p>The Air Filter may need to be set to the MAX setting or replaced.</p> <ul style="list-style-type: none"> • Set the Air Filter to the MAX setting. If the odor does not go away within 24 hours, the filter may need to be replaced. See the Replacing the Air Filter section for replacement instructions.
<p>The interior of the refrigerator is covered with dust or soot.</p>	<p>The refrigerator is located near a fire source, such as a fireplace, chimney, or candle.</p> <ul style="list-style-type: none"> • Make sure that the refrigerator is not located near a fire source, such as a fireplace, chimney or candle.

Problem	Possible Cause & Solution
	<ul style="list-style-type: none"> • Refer to the Leveling and Door Alignment section.
	<p>Floor is not level.</p> <ul style="list-style-type: none"> • It may be necessary to add shims under the leveling legs or rollers to complete installation.
<p>Lights do not work.</p>	<p>LED interior lighting failure.</p> <ul style="list-style-type: none"> • The refrigerator compartment lamp is LED interior lighting, and service should be performed by a qualified technician.
<p>Refrigerator has an unusual odor.</p>	<p>The Air Filter may need to be set to the MAX setting or replaced.</p>

Problem	Possible Cause & Solution
Clicking	<p>Normal Operation Some models will also click when cycling on and off. The thermostat control (or refrigerator control on some models) will also click when cycling on and off.</p>
Rattling	<p>Normal Operation Rattling noises may come from the flow of refrigerant, the water line on the back of the unit, or items stored on top of or around the refrigerator.</p> <p>Normal Operation Refrigerator is not resting solidly on the floor.</p> <ul style="list-style-type: none"> • Floor is weak or uneven or leveling legs need to be adjusted. See the Refrigerator is not resting solidly on the floor. • Floor is weak or uneven or leveling legs need to be adjusted. See the Leveling and Door Alignment section. • Normal Operation Refrigerator with linear compressor was jarred while running. • Normal Operation Evaporator fan motor is circulating air through the refrigerator and freezer compartments.
Whooshing	<p>Normal Operation Evaporator fan motor is circulating air through the refrigerator and freezer compartments.</p> <p>Normal Operation Air is being forced over the condenser by the condenser fan.</p> <ul style="list-style-type: none"> • Normal Operation Air is being forced over the condenser by the condenser fan. • Normal Operation Refrigerant flowing through the cooling system.
Gurgling	<ul style="list-style-type: none"> • Normal Operation Refrigerant flowing through the cooling system. • Normal Operation Contraction and expansion of the inside walls due to changes in temperature.
Popping	<p>Normal Operation Contraction and expansion of the inside walls due to changes in temperature.</p> <p>Normal Operation Water dripping on the defrost heater during a defrost cycle.</p>
Sizzling	<ul style="list-style-type: none"> • Normal Operation Water dripping on the defrost heater during a defrost cycle. • Normal Operation If the side or back of the refrigerator is touching a cabinet or wall, some of the normal vibrations may make an audible sound.



Problem	Possible Cause & Solution
	<ul style="list-style-type: none"> To eliminate the noise, make sure that the sides and back cannot vibrate against any wall or cabinet.
Dripping	<p>Water running into the drain pan during the defrost cycle.</p> <ul style="list-style-type: none"> Normal Operation
Pulsating or high pitched sound	<p>Your refrigerator is designed to run more efficiently to keep your food items at the desired temperature. The high efficiency compressor may cause your new refrigerator to run longer than your old one, but it is still more energy efficient than previous models. While the refrigerator is running, it is normal to hear a pulsating or high pitched sound.</p> <ul style="list-style-type: none"> Normal Operation

Problem	Possible Cause & Solution
Vibrating	<p>If the side or back of the refrigerator is touching a cabinet or wall, some of the normal vibrations may make an audible sound.</p> <ul style="list-style-type: none"> To eliminate the noise, make sure that the sides and back cannot vibrate against any wall or cabinet.
Dripping	<p>Water running into the drain pan during the defrost cycle.</p> <ul style="list-style-type: none"> Normal Operation
Pulsating or high pitched sound	<p>Your refrigerator is designed to run more efficiently to keep your food items at the desired temperature. The high efficiency compressor may cause your new refrigerator to run longer than your old one, but it is still more energy efficient than previous models. While the refrigerator is running, it is normal to hear a pulsating or high pitched sound.</p> <ul style="list-style-type: none"> Normal Operation

Warning



This content is compiled from multiple sources and is provided for reference purposes only. It may not be complete or fully applicable to all situations. If you are unable to resolve your issue, please contact the product manufacturer or an authorized service provider for official support.

Document generated by [ManualsFile](#)

