

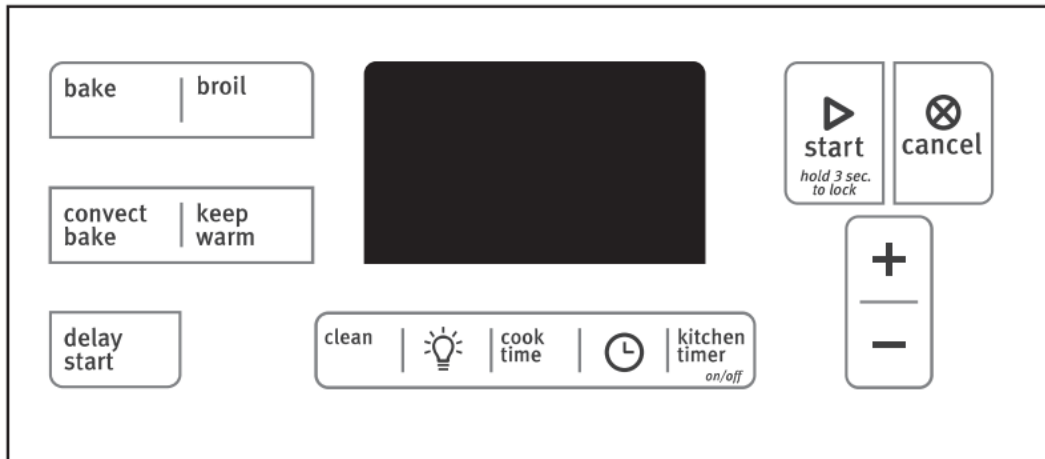

USER INSTRUCTIONS Gas Range

FEATURE GUIDE

This manual covers several models. Your model may have some or all of the items listed. Refer to this manual or the Frequently Asked Questions (FAQs) section of our website at www.maytag.com for more detailed instructions.



WARNING - Food Poisoning Hazard: Do not let food sit in oven more than one hour before or after cooking. Doing so can result in food poisoning or sickness.

KEYPAD	FEATURE	INSTRUCTIONS
CLOCK 	Clock	<p>The Clock uses a 12-hour cycle.</p> <ol style="list-style-type: none"> 1. Check that the oven is off. 2. Press CLOCK. 3. Press TEMP/TIME "+" or "-" keypads to set the time of day. 4. Press CLOCK or START.
OVEN LIGHT 	Oven cavity light	<p>The oven light is controlled by a keypad on the oven control panel. While the door is closed, press the oven light switch to turn the light on and off. The light will come on when the oven door is opened.</p>
KITCHEN TIMER (on/off)	Oven timer	<p>The Kitchen Timer can be set in hours or minutes up to 12 hours and 59 minutes.</p> <ol style="list-style-type: none"> 1. Press KITCHEN TIMER. 2. Press TEMP/TIME "+" or "-" keypads to set the length of time. 3. Press START to begin the countdown. If enabled, end-of-cycle chime will sound at end of countdown. 4. Press KITCHEN TIMER twice to cancel the Timer. Do not press the Cancel keypad because the oven will turn off. 5. If the Kitchen Timer is running, but not in the display, press KITCHEN TIMER to display the countdown for 5 seconds.
START	Cooking start	<p>The Start pad begins any oven function. If Start is not pressed within 5 seconds, "PUSH" appears in the display. If Start is not pressed within 1 minute after pressing a keypad, the function is canceled and the time of day is displayed.</p>
CANCEL	Range function	<p>The Cancel keypad stops any function except the Clock, Kitchen Timer, and Oven Control Lockout.</p>
TEMP/TIME	Temperature and time adjust	<p>The "+" or "-" keypads are used to adjust time and temperature settings.</p>
BAKE	Baking and roasting	<ol style="list-style-type: none"> 1. Press BAKE. 2. Press TEMP/TIME "+" or "-" keypads to set a temperature other than 350°F (175°C) in 5° increments between 170°F and 525°F (70°C and 275°C). 3. Press START.

4. To change the temperature, repeat Step 2. Press START or wait 30 seconds for the change to take effect.
5. Press CANCEL when finished.

BROIL	Broiling	<ol style="list-style-type: none"> 1. Press BROIL. 2. Press Temp/Time “+” or “-” keypads to change the temperature in 5° increments between 300°F and 500°F (150°C and 260°C). 3. Press START, and allow oven to preheat for 5 minutes. 4. Position cookware in oven and close the oven door. 5. Press CANCEL when finished.
--------------	-----------------	---

CONVECT	Convection baking and roasting	<ol style="list-style-type: none"> 1. Press CONVECT BAKE. 2. Press Temp/Time “+” or “-” keypads to set a temperature other than 350°F (175°C) in 5° increments between 170°F and 500°F (75°C and 260°C). 3. Press START. 4. To change the temperature, repeat Step 2. Press START for temperature to take effect. 5. Press CANCEL when finished.
----------------	---------------------------------------	---

KEEP WARM	Hold warm	<p>Food must be at serving temperature before placing it in the warmed oven.</p> <ol style="list-style-type: none"> 1. Press KEEP WARM. 2. Temperature is set at 170°F (75°C) for 60 minutes (1.00 hours). 3. Press START. 4. Press CANCEL when finished. <p>NOTE: The oven will automatically turn off after 60 minutes.</p>
------------------	------------------	---

DELAY START **Delayed start** The Delay Start keypad is used to enter the starting time for an oven function with a delayed start. Delay start should not be used for foods such as breads and cakes because they may not bake properly.

To set a Timed Cook or a Delayed Timed Cook, see “Timed Cooking” section.

COOK TIME	Timed cooking	<p>Timed Cooking allows the oven to be set to turn on at a certain time of day for a set length of time, and/or shut off automatically.</p> <p>To set a Timed Cook or a Delayed Timed Cook, see “Timed Cooking” section.</p>
------------------	----------------------	--



CLEAN	Clean cycle	See the “Clean Cycle” section.
START (hold 3 sec to lock)	Oven control lockout	<ol style="list-style-type: none"> 1. Check that the oven is off. 2. Press and hold the START (hold 3 sec to lock) keypad for 3 s 3. A tone will sound, and “Loc” will be displayed. 4. Repeat to unlock. Only the Clock, Kitchen Timer and Oven Li keypads will function with the controls locked. The cooktop fu not affected by the oven control lockout.

COOKTOP USE

WARNING - Fire Hazard: Turn off all controls when done cooking. Failure to do so can result in death or fire.

- Electric igniters automatically light the surface burners when control knobs are turned to Lite. 4Before setting a control knob, place filled cookware on the grate. Do not operate a burner using empty cookware or without cookware on the grate.

To Set:

1. Push in and turn knob counterclockwise to LITE. All surface burners will click. Only the burner with the control knob turned to Lite will produce a flame.
2. Turn knob to anywhere between HIGH and LOW

REMEMBER: When range is in use, the entire cooktop area may become hot.

Power Failure

- In case of prolonged power failure, the surface burners can be lit manually. Hold a lit match near a burner and turn knob counterclockwise to LITE. After burner lights, turn knob to setting.

Sealed Surface Burners

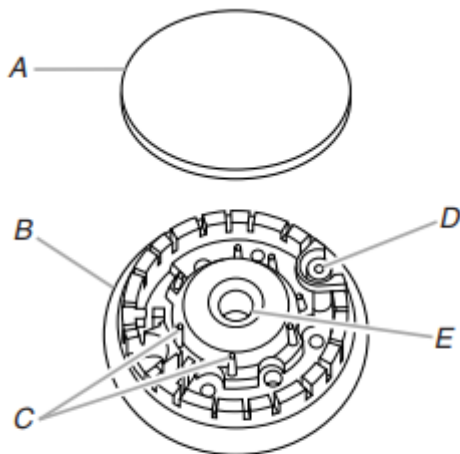

A. Burner cap
B. Burner base
C. Alignment pins
D. Igniter
E. Gas tube opening

- **IMPORTANT:** Do not obstruct the flow of combustion and ventilation air around the burner grate edges.
- **Burner cap:** Always keep the burner cap in place when using a surface burner. A clean burner cap will help avoid poor ignition and uneven flames. Always clean the burner cap after a spillover and routinely remove and clean the caps according to the “General Cleaning” section.
- **Gas tube opening:** Gas must flow freely throughout the gas tube opening for the burner to light properly. Keep this area free of soil and do not allow spills, food, cleaning agents or any other material to enter the gas tube opening. Keep spillovers out of the gas tube by always using a burner cap.

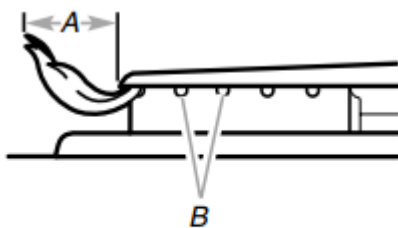

A. 1-1½" (25-38 mm)
B. Burner ports

Burner ports: Check burner flames occasionally for proper size and shape as shown in the previous illustration. A good flame is blue in color, not yellow. Keep this area free of soil and do not allow spills, food, cleaning agents or any other material to enter the burner ports.

To Clean:

IMPORTANT: Before cleaning, make sure all controls are off and the oven and cooktop are cool. Do not use oven cleaners, bleach or rust removers.

1. Remove the burner cap from the burner base and clean according to “General Cleaning” section.
2. Clean the gas tube opening with a damp cloth.
3. Clean clogged burner ports with a straight pin as shown. Do not enlarge or distort the port. Do not use a wooden toothpick. If the burner needs to be adjusted, contact a trained repair specialist.

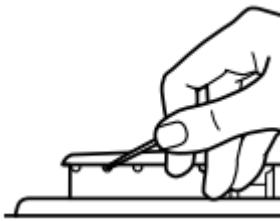

4. Replace the burner cap, making sure the alignment pins are properly aligned with the burner cap.



A. Incorrect
B. Correct

5. Turn on the burner. If the burner does not light, check cap alignment. If the burner still does not light, do not service the sealed burner yourself. Contact a trained repair specialist.

Burner Size

Select a burner that best fits your cookware. See the following illustration and chart.

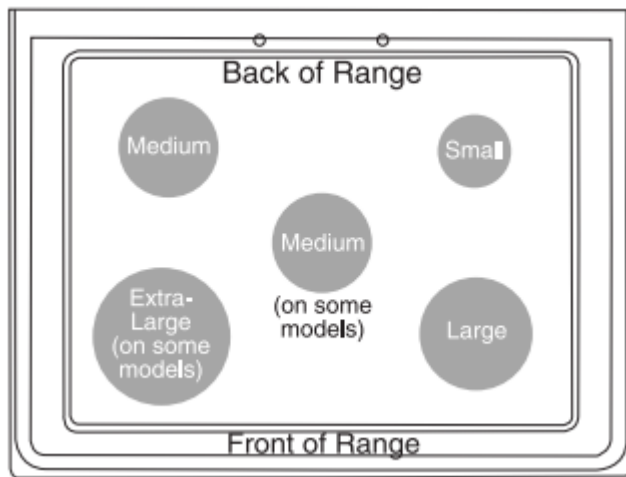

Burner Size	Recommended Use
Small	<ul style="list-style-type: none"> • Low-heat cooking • Melting chocolate or butter
Medium	<ul style="list-style-type: none"> • Multipurpose burner
Large	<ul style="list-style-type: none"> • For large cookware
Extra-Large	<ul style="list-style-type: none"> • Most powerful burner • For large cookware

Cookware

IMPORTANT: Do not leave empty cookware on a hot surface cooking area, element or surface burner.

- Ideal cookware should have a flat bottom, straight sides and a wellfitting lid, and the material should be of medium-to-heavy thickness.
- Rough finishes may scratch the cooktop or grates. Aluminum and copper may be used as a core or base in cookware. However, when used as a base they can leave permanent marks on the grates.
- Cookware material is a factor in how quickly and evenly heat is transferred, which affects cooking results.
- Cookware with nonstick surfaces should not be used under the broiler.

- Check for flatness by placing the straight edge of a ruler across the bottom of the cookware. While you rotate the ruler, no space or light should be visible between it and the cookware.

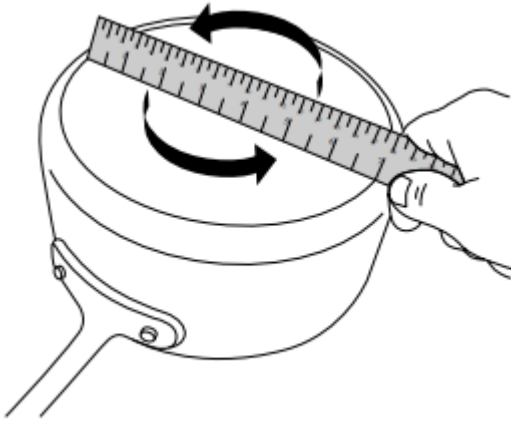

- Use the following chart as a guide for cookware material characteristics.

COOKWARE	CHARACTERISTICS
Aluminum	• Heats quickly and evenly.
	• Suitable for all types of cooking.
	• Medium or heavy thickness is best for most cooking tasks.
Cast iron	• Heats slowly and evenly.
	• Good for browning and frying.
	• Maintains heat for slow cooking.
Ceramic or Ceramic glass	• Follow manufacturer's instructions. • Heats slowly, but unevenly.
	• Ideal results on low to medium heat settings.
Copper	• Heats very quickly and evenly.
Earthenware	• Follow manufacturer's instructions.
	• Use on low heat settings.
Porcelain enamel-on-steel or cast iron	• See stainless steel or cast iron.
Stainless steel	• Heats quickly, but unevenly.
	• A core or base of aluminum or copper on stainless steel provides even heating.

For best results, the cookware should be centered above the burner with the bottom sitting level on the grate. The flame should be adjusted so that it does not extend up the sides of the pan.



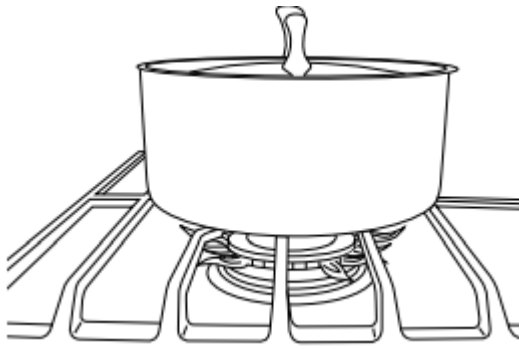

Home Canning

When canning for long periods, alternate the use of surface burners between batches. This allows time for the most recently used areas to cool.

- Center the canner on the grate above the burner.
- Do not place canner on 2 surface burners at the same time.
- For more information, contact your local agricultural extension office, or refer to published home canning guides. Companies that manufacture home canning products can also offer assistance.

OVEN USE

The normal operation of the range will include several noises that may be heard each time the Bake or Broil burners ignite during the cooking cycle:

- gas valves may make a “popping” sound when opening or closing
- igniters will “click” several times until a flame is sensed
- a “poof” sound is heard when a Bake or Broil burner ignites

Odors and smoke are normal when the oven is used the first few times, or when it is heavily soiled.

IMPORTANT: The health of some birds is extremely sensitive to the fumes given off. Exposure to the fumes may result in death to certain birds. Always move birds to another closed and wellventilated room.

Electronic Oven Controls

Control Display

- The display will flash when powered up or after a power loss. Press CANCEL to clear. When oven is not in use, the time of day is displayed. Indicator lights show functions that are in use.

Tones

Tones are audible signals, indicating the following:

Basic Functions

- One tone
 - Valid pad press
 - Oven is preheated (long tone)
 - Function has been entered
 - Reminder (on some models), repeating every 20 seconds after the end-of-cycle tones
- Three tones
 - Invalid pad press
- Four tones
 - End of cycle

Energy Save

- The Energy Save feature places the control and clock into a Sleep mode that reduces power consumption when the range is not being used.
- To enter the Energy Save mode, the oven and control must be idle with the time of day shown on the display. Press and hold CLOCK for 10 seconds. The control will beep and the display will show the letters “ES” followed by “On” twice. The display will return to the time of day.
- If Energy Save mode is activated, each time the range is idle for 5 minutes with only the time of day shown, the display will show the letters “ES” followed by “On” twice. The display will then be blank until a control key is pressed or the oven door is opened. The control will then perform any of its operations in response to additional key presses.
- To exit Energy Save mode, press and hold the CLOCK key for 10 seconds. The control will beep and the display will show the letters “ES” followed by “Off” twice. The display will return to the time of day

Oven Temperature Control

IMPORTANT: Do not use a thermometer to measure oven temperature because opening the oven door may cause element cycling to give incorrect readings.

The oven provides accurate temperatures; however, it may cook faster or slower than your previous oven, so the temperature can be adjusted to personalize it for your cooking needs. It can be changed in Fahrenheit or Celsius.

To Adjust Oven Temperature:

1. Press and hold BAKE for 5 seconds until the oven display shows the current calibration, for example “0°F CAL” or “00.”

2. Press the Temp/Time “+” or “-” keypads to increase or to decrease the temperature in 10°F (5°C or 6°C) amounts. The adjustment can be set between 30°F (17°C) and -30°F (-17°C).
3. Press START.

Options Mode

- Press and hold KITCHEN TIMER for 5 seconds, and “Opt” will appear. Use the TEMP/TIME keys to cycle through the following options. Press CANCEL to exit the mode.
- Fahrenheit and Celsius: The temperature is preset at Fahrenheit, but can be changed to Celsius. Press KITCHEN TIMER to toggle between Fahrenheit and Celsius. Press CANCEL to exit.
- End of Cycle: Tones “b1” (beep once) or “b” (continue to beep) will be displayed. Press KITCHEN TIMER to toggle through selections. Press CANCEL to exit.
- Oven Light with Door Open: “LOn” indicates that the oven light will turn on when the door is open. If “LOFF” is displayed, the oven light will turn on only with the oven light switch. Press KITCHEN TIMER to toggle through selection. Press CANCEL to exit.
- 12-Hour Shutoff: If “12 Hr” is displayed, the oven will automatically shut off after 12 hours. Press KITCHEN TIMER to toggle to “- Hr” to disable the 12-hour shutoff. Press CANCEL to exit.

Sabbath Mode

The Sabbath Mode sets the oven to remain on in a Bake setting until turned off. A Timed Bake can also be set to keep the oven on for only part of the Sabbath. The Oven Control Lockout Feature (if present) will be disabled during the Sabbath Mode. After the Sabbath Mode is set no tones will sound, the display will not show the temperature, the Kitchen Timer Mode will be canceled (if active) and only the following pads will function:

- “+” or “-” keypads (if present)
- Cancel

When the oven door is opened or closed, the oven light will not turn on or off and the heating elements will not turn on or off immediately.

When power is restored after a power failure, the oven will return to Sabbath Mode and remain Sabbath compliant with the bake elements off until the Cancel keypad is pressed.

Pressing the Cancel keypad at any time returns the oven to the normal cooking mode (not Sabbath Mode compliant).

Before entering the Sabbath Mode, it must be decided if the oven light is to be on or off for the entire Sabbath Mode period. If the light is on when entering Sabbath Mode, it will remain on for the entire time Sabbath Mode is in use. If the light is off when entering Sabbath Mode, it will remain off

for the entire time Sabbath Mode is in use. Opening the oven door or pressing the Oven Light keypad will not affect the oven light once Sabbath Mode has been entered.

If the oven has the Convection Bake feature, the oven light is controlled by a separate Oven Light switch on the console. If the oven light is on when entering the Sabbath Mode, it will remain on for the entire time Sabbath Mode is in use. For the oven light to be off during the Sabbath Mode, the light bulb must be removed from the oven prior to entering the Sabbath Mode. Not performing these steps will cause the oven light to turn on when the oven door is opened, resulting in the oven being not Sabbath compliant.

On the Holiday, the oven temperature can be changed once the oven is in Sabbath Mode by pressing the “+” or “-” keypads (if present) or the “More” or “Less” keypads (if present). The oven temperature will change 25°F (14°C) each time the keypad is pressed. The display will not change, and there will be no sounds during this adjustment.

To Bake using Sabbath Mode:

1. Press BAKE.
2. Press the “+” or “-” keypads (if present) or “MORE” or “LESS” keypads (if present).
3. Press START.
4. Press and hold the TIMER keypad for 5 seconds, “SAb” will flash in the display.
5. Press START within 5 seconds to enter Sabbath Mode; otherwise, the entire cycle cancels out. “SAb” will stop flashing and remain on in the display. The oven is now in Sabbath Mode and is Sabbath compliant.

Pressing the Cancel keypad at any time returns the oven to the normal cooking mode (not Sabbath Mode compliant).

To set a Timed Bake using Sabbath Mode (on some models):

WARNING - Food Poisoning Hazard: Do not let food sit in oven more than one hour before or after cooking. Doing so can result in food poisoning or sickness.

1. Press BAKE.
2. Press the “+” or “-” keypads (if present) or “MORE” or “LESS” keypads (if present) to enter a temperature other than the one displayed.
3. Press COOK TIME. The Cook Time oven indicator light will light up.
4. Press the “+” or “-” keypads (if present) or “MORE” or “LESS” keypads (if present) to enter a cook time length.
5. Press START.
6. Press and hold the TIMER keypad for 5 seconds. “SAb” will flash in the display.
7. Press START within 5 seconds to enter Sabbath Mode; otherwise, the entire cycle cancels out. “SAb” will stop flashing and remain on in the display. The oven is now in

Sabbath Mode and is Sabbath compliant. The On and Timer indicator lights will be displayed.

When the start time is reached the Bake and On indicator lights will automatically turn on. When the set cook time ends, the oven will shut off automatically and the indicator lights will turn off, indicating the end of the cycle.

Pressing the Cancel keypad at any time returns the oven to the normal cooking mode (not Sabbath Mode compliant).

To set a Delayed Timed Bake using Sabbath Mode (on some models):

1. Press BAKE.
2. Press the "+" or "-" keypads (if present) or "MORE" or "LESS" keypads (if present) to enter a temperature other than the one displayed.
3. Press COOK TIME. The Cook Time oven indicator light will light up.
4. Press the "+" or "-" keypads (if present) or "MORE" or "LESS" keypads (if present) to enter a cook time length.
5. Press START TIME or DELAY START. The Start Time/Delay Start indicator light will light up.
6. Press the "+" or "-" keypads (if present) or "MORE" or "LESS" keypads (if present) to enter a start time.
7. Press START.
8. Press and hold the TIMER keypad for 5 seconds. "SAb" will flash in the display.
9. Press START within 5 seconds to enter Sabbath Mode; otherwise, the entire cycle cancels out. "SAb" will stop flashing and remain on in the display. The oven is now in Sabbath Mode and is Sabbath compliant. The On and Delay indicator lights will be displayed. When the start time is reached the Bake and On indicator lights will automatically turn on.

When the set cook time ends, the oven will shut off automatically and the indicator lights will turn off, indicating the end of the cycle.

Pressing the Cancel keypad at any time returns the oven to the normal cooking mode (not Sabbath Mode compliant).

Aluminum Foil

- **IMPORTANT:** To avoid permanent damage to the oven bottom finish, do not line the oven bottom with any type of foil or liner.
- For best cooking results, do not cover entire oven rack with foil because air must be able to move freely.



Positioning Racks and Bakeware

IMPORTANT: To avoid permanent damage to the porcelain finish, do not place food or bakeware directly on the oven door or bottom.

Bakeware

- To cook food evenly, hot air must be able to circulate. Allow 2" (5 cm) of space around bakeware and oven walls. Make sure that no bakeware piece is directly over another.

Racks

- Position racks before turning on the oven.
- Do not move racks with bakeware on them.
- Make sure racks are level.

To move a rack, pull it out to the stop position, raise the front edge, and then lift out. Use the following illustration and charts as a guide.

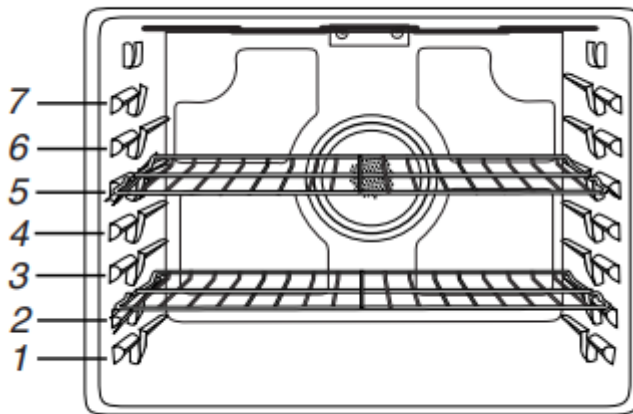

Rack Positions

- 7: Broiling very thin, non-fatty foods.
- 6: Most broiling.
- 5: Multiple rack baking.
- 3 or 4: Most baked goods, casseroles
- 1: Roasting large cuts of meat and poultry.

*If your model has a Max Capacity Oven Rack, the recessed ends must be placed in the rack position above the desired position of the food. See the following illustration

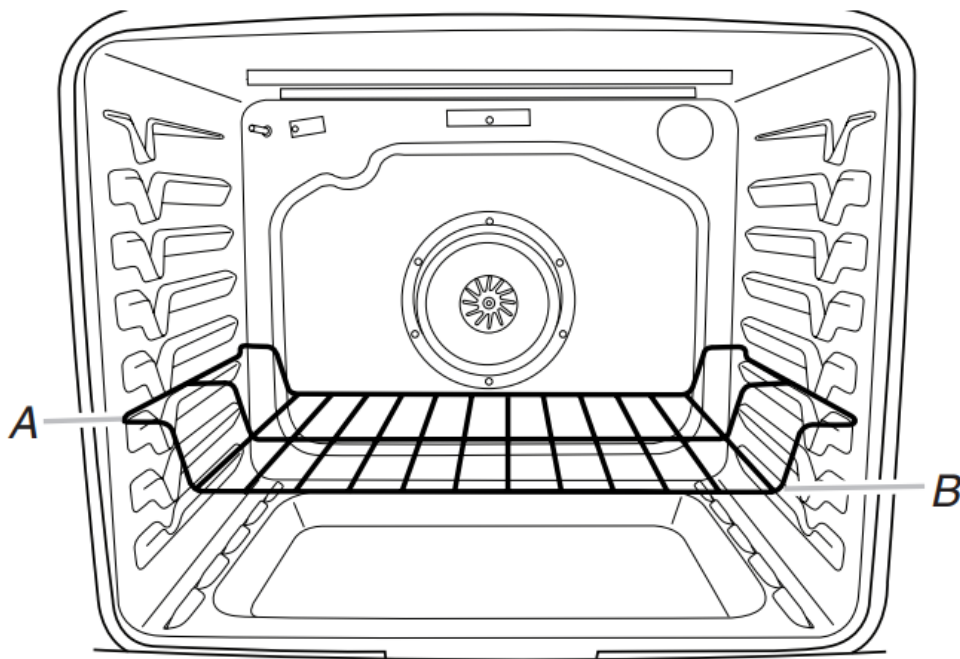

A. Ends of rack in position 3
B. Food in position 2

IMPORTANT: These rack positions are for flat racks. If a Max Capacity Oven Rack is used, the rack position must be adjusted as shown in the previous figure.

Multiple Rack Cooking

- 2-rack (non-convection): Use rack positions 2 and 5.
- 2-rack (convection): Use rack positions 2 and 5 or 3 and 6.

Baking Layer Cakes on 2 Racks

- For best results when baking cakes on 2 racks, use racks 2 and 5. For best results when convection baking cakes on 2 racks, use racks 2 and 5. Place the cakes on the racks as shown.

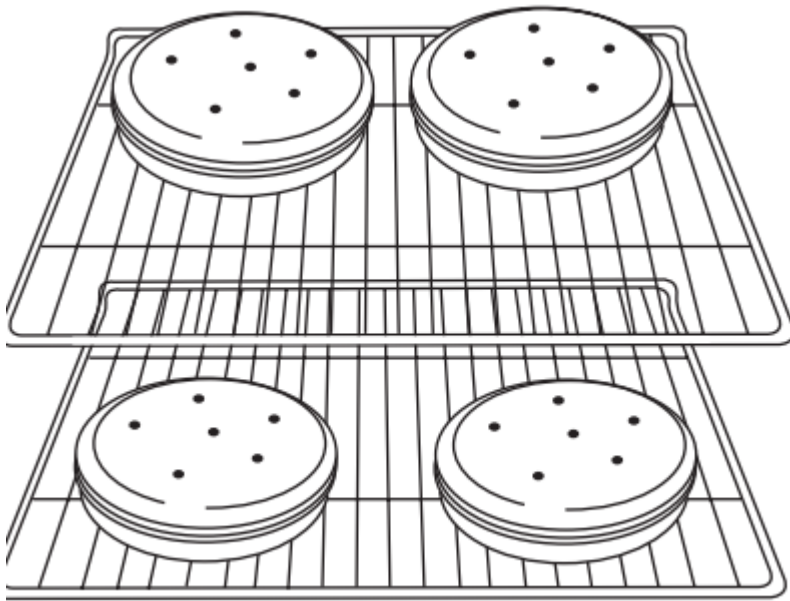

Oven Vent

- The oven vent releases hot air and moisture from the oven, and should not be blocked or covered. Blocking or covering the vent will cause poor air circulation, affecting cooking and cleaning results. Do not set plastics, paper or other items that could melt or burn near the oven vent.

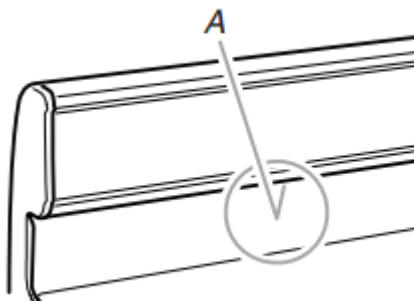

A. Oven vent

Baking and Roasting

PRECISE BAKE Temperature Management System (on some models)

- The PRECISE BAKE system electronically regulates the oven heat levels during preheat and bake to maintain a precise temperature range for optimal cooking results. The bake and broil elements or burners cycle on and off in intervals. On convection range models, the fan may be cycled on and off for short intervals to provide the best results.
- Before baking and roasting, position racks according to “Positioning Racks and Bakeware” section. When roasting, it is not necessary to wait for the oven preheat cycle to end before putting food in unless it is recommended in the recipe.

Preheating

- When START is pressed, the oven will begin preheating. Once 100°F (38°C) is reached, the display temperature will increase as the actual temperature of the oven increases. When the preheat temperature is reached, a tone will sound, and the selected temperature will appear on the display. The time necessary to preheat the oven to 350°F (177°C) is approximately 10 to 15 minutes. Factors that have an impact on preheat times are: room temperature, starting oven temperature, and the number of oven racks. Unused oven racks can be removed prior to preheating your oven to reduce the preheat times.

Broiling

- When broiling, preheat the oven for 5 minutes before putting food in unless recommended otherwise in the recipe. Position food on grid in a broiler pan, then place it in the center of the oven rack.
- **IMPORTANT:** Close the door to ensure proper broiling temperature.
- Changing the temperature when Custom Broiling allows more precise control when cooking. The lower the broil setting, the slower the cooking. Thicker cuts and unevenly shaped pieces of meat, fish and poultry may cook better at lower broil settings. Use racks 6 or 7 for broiling. Refer to the “Positioning Racks and Bakeware” section for more information.
 - For best results, use a broiler pan and grid. It is designed to drain juices and help avoid spatter and smoke. If you would like to purchase a broiler pan, one may be ordered. Please refer to the “Accessories” section for more information.

NOTE: Odors and smoke are normal the first few times the oven is used or if the oven is heavily soiled.

Convection Baking and Roasting (on some models)

- In a convection oven, the fan-circulated hot air continually distributes heat more evenly than the natural movement of air in a standard thermal oven. This movement of hot air helps maintain a consistent temperature throughout the oven, cooking foods more evenly, crisping surfaces while sealing in moisture and yielding crustier breads

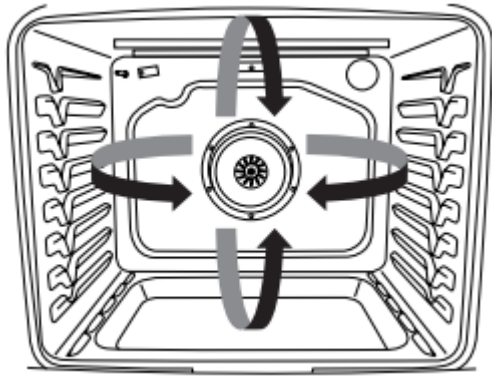

- With convection cooking, most foods can be cooked at a temperature 25°F (14°C) lower than in a standard thermal oven, and cooking time can be shortened by up to 30%.
- During convection baking or roasting, the bake and broil elements or burners cycle on and off in intervals to maintain the oven temperature, while the fan circulates the hot air. The convection fan will not be on during the first 5 minutes of the cycle.
- If the oven door is opened during convection baking or roasting, the fan will turn off immediately. It will come back on when the oven door is closed.

Timed Cooking

WARNING - Food Poisoning Hazard: Do not let food sit in oven more than one hour before or after cooking. Doing so can result in food poisoning or sickness.

To Set a Timed Cook:

1. Press **BAKE**. The bake indicator light will light up.
2. Press the **TEMP/TIME “+”** or **“-”** keypads to enter a temperature other than the one displayed.
3. Press **COOK TIME**. The cook time oven indicator light will light up.
4. Press the **TEMP/TIME “+”** or **“-”** keypads to enter the length of time to cook.
5. Press **START**. The display will count down the time. When the time ends, the oven will shut off automatically and “End” will appear on the display.
6. Press **CANCEL** to clear the display.

To Set a Delayed Timed Cook:

Before setting, make sure the clock is set to the correct time of day. See the “Clock” keypad feature in the “Feature Guide” section.

1. Press **BAKE**.
2. Press the **TEMP/TIME “+”** or **“-”** keypads to enter a temperature other than the one displayed.
3. Press **COOK TIME**. The cook time oven indicator light will light up.

4. Press TEMP/TIME “+” or “-” keypads to enter the length of time to cook.
5. Press DELAY START. The delay oven indicator light will light up.
6. Press TEMP/TIME “+” or “-” keypads to enter the time of day to start.
7. Press START. When the start time is reached, the oven will automatically turn on. The temperature and/or time settings can be changed anytime after pressing Start by repeating steps 1-7. When the set cook time ends, the oven will shut off automatically and “End” will appear on the display.
8. Press CANCEL to clear the display.

RANGE CARE

Clean Cycle



AquaLift™ Technology is an innovative cleaning solution that utilizes heat and water to release baked-on spills from the oven in less than 1 hour. This new cleaning technology is a low-heat, odorfree alternative to traditional self-cleaning options.

Allow the oven to cool to room temperature before using the Clean cycle. If your oven cavity is above 200°F (93°C), “HOT” will appear in the display, and the Clean cycle will not be activated until the oven cavity cools down.

To Clean:

1. Remove all racks and accessories from the oven cavity and wipe excess soil. Use a plastic scraper to remove easily removed soils.

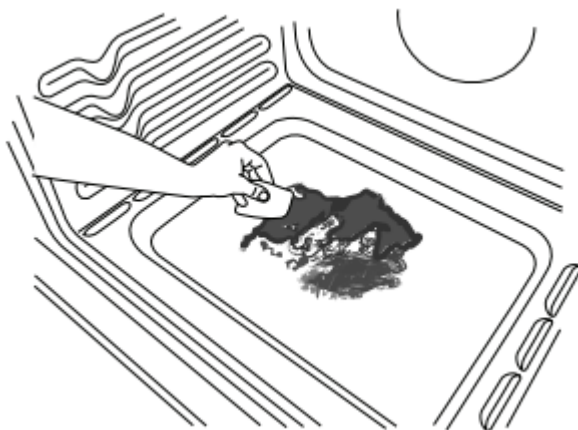

2. Pour 1¾ cups (14 oz [414 mL]) of distilled or filtered water onto the bottom of the empty oven and close the oven door.

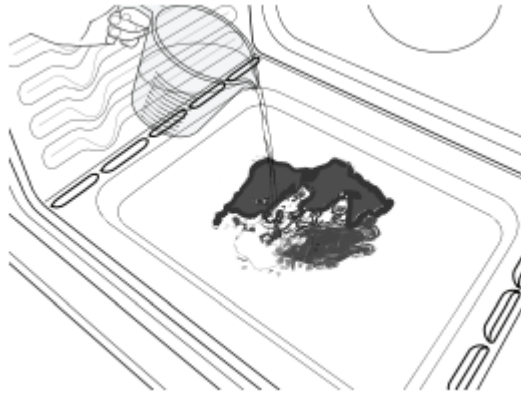

IMPORTANT: Do not use chemicals or other additives with the water. Do not open the oven door during the Clean cycle. The water on the oven bottom is hot.

3. Press CLEAN and then START on the oven control panel.

4. Allow 40 minutes for cleaning and cool down. A beep will sound when the Clean cycle is complete.

5. Press CANCEL at the end of the cycle. CANCEL may be pressed at any time to stop the Clean cycle.

6. Remove the residual water and loosened soils with a sponge or cloth immediately after the Clean cycle is complete. Much of the initial 1¾ cups (14 oz [414 mL]) of water will remain in the oven after the cycle is completed. If additional soils remain, leave a small amount of water in the oven bottom to assist with the cleaning.

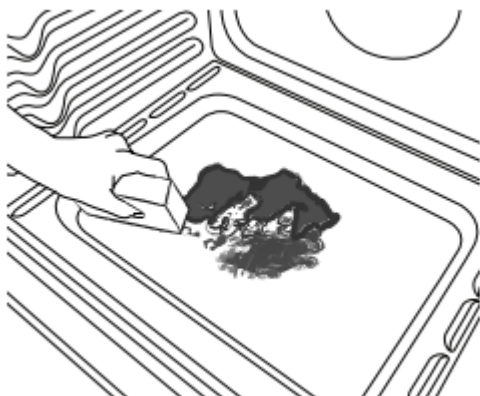

7. If any soils remain, remove them with a non-scratch scrubbing sponge or plastic scraper. Additional Clean cycles may be run to help remove the stubborn soils.

IMPORTANT: Do not use oven cleaners. The use of chemicals, including commercial oven cleaners or metal scouring pads, may cause permanent damage to the porcelain surface of the oven interior.

NOTES:

- The range should be level to ensure that the entire surface of the bottom of the oven cavity is covered by water at the beginning of the Clean cycle.
- For best results, use distilled or filtered water. Tap water may leave mineral deposits on the oven bottom.
- Before removing the residual water and loosened soils at the end of the Clean cycle, insert a cloth or paper towel between the lower edge of the oven door and the front frame to keep water from spilling onto the front of the range and the floor.
- Soil baked on through several cooking cycles will be more difficult to remove with the Clean cycle.
- Nonabrasive scrub sponges or eraser style cleaning pads (without cleaners) can be effective for cleaning the oven cavity walls, oven door and oven bottom for difficult soils. For best results, moisten the pads and sponges before use.
- Run an additional Clean cycle for stubborn soils.
- affresh™ Kitchen and Appliance Cleaner and affresh™ Cooktop Cleaner may be used to clean the oven bottom, walls and door when the oven has finished the cycle and returned to room temperature. Refer to the “Accessories” section for information on ordering.
- Additional AquaLift™ Technology Cleaning Kits may be obtained by ordering Part Number W10423113RP. See the “Accessories” section for more information.
- For assistance with AquaLift™ Technology, call 1-877-258-0808, or visit our website at whr.pl/aqualift.

General Cleaning

IMPORTANT: Before cleaning, make sure all controls are off and the oven and cooktop are cool. Always follow label instructions on cleaning products. For additional information, you can visit the Frequently Asked Questions (FAQs) section of our website at www.maytag.com.

Soap, water and a soft cloth or sponge are suggested first unless otherwise noted.

EXTERIOR PORCELAIN ENAMEL SURFACES (on some models)

Food spills containing acids, such as vinegar and tomato, should be cleaned as soon as the entire range is cool. These spills may affect the finish.

Cleaning Method:

- Glass cleaner, mild liquid cleaner or nonabrasive scrubbing pad: Gently clean around the model and serial number plate because scrubbing may remove numbers.
- affresh™ Kitchen and Appliance Cleaner Part Number W10355010 (not included): See the “Accessories” section for more information.

STAINLESS STEEL (on some models)

NOTE: To avoid damage to stainless steel surfaces, do not use soap-filled scouring pads, abrasive cleaners, Cooktop Cleaner, steel-wool pads, gritty washcloths or abrasive paper towels. Damage may occur to stainless steel surfaces, even with one-time or limited use.

Cleaning Method: Rub in direction of grain to avoid damaging.

- affresh™ Stainless Steel Cleaner Part Number W10355016 (not included): See the “Accessories” section for more information.

Liquid detergent or all-purpose cleaner: Rinse with clean water and dry with soft, lint-free cloth.

METALLIC PAINT (on some models)

- Do not use abrasive cleaners, cleaners with bleach, rust removers, ammonia or sodium hydroxide (lye) because paint surface may stain.

PORCELAIN-COATED GRATES AND CAPS

Food spills containing acids, such as vinegar and tomato, should be cleaned as soon as the cooktop, grates and caps are cool. These spills may affect the finish.

To avoid chipping, do not bang grates and caps against each other or hard surfaces such as cast iron cookware.

Do not reassemble caps on burners while wet.

Cleaning Method:

- Nonabrasive plastic scrubbing pad and mildly abrasive cleanser: Clean as soon as cooktop, grates and caps are cool.
- Dishwasher (grates only, not caps): Use the most aggressive cycle. Cooked-on soils should be soaked or scrubbed before going into a dishwasher.
- Gas Grate and Drip Pan Cleaner Part Number 31617: See the “Accessories” section for more information.

SURFACE BURNERS

- See “Sealed Surface Burners” section.

COOKTOP CONTROLS

To avoid damage to the cooktop controls, do not use steel wool, abrasive cleansers or oven cleaner.

To avoid damage, do not soak knobs.

When replacing knobs, make sure knobs are in the OFF position. On some models, do not remove seals under knobs.

Cleaning Method:

- Soap and water: Pull knobs straight away from control panel to remove.

CONTROL PANEL AND OVEN DOOR EXTERIOR

To avoid damage to the control panel, do not use abrasive cleaners, steel-wool pads, gritty washcloths or abrasive paper towels.

Cleaning Method:

- Glass cleaner and soft cloth or sponge: Apply glass cleaner to soft cloth or sponge, not directly on panel.
- affresh™ Kitchen and Appliance Cleaner Part Number W10355010 (not included): See the “Accessories” section for more information.

OVEN RACKS

Cleaning Method:

- Steel-wool pad
- For racks that have discolored and are harder to slide, a light coating of vegetable oil applied to the rack guides will help them slide.

STORAGE DRAWER

Check that storage drawer or warming drawer is cool and empty before cleaning.

Cleaning Method:

- Mild detergent

OVEN CAVITY

Use AquaLift™ Technology regularly to clean oven spills.

Do not use oven cleaners.

Food spills should be cleaned when oven cools. At high temperatures, foods react with porcelain and staining, etching, pitting or faint white spots can result.

Cleaning Method:

- Clean cycle: See “Clean Cycle” section

Oven Light

The oven light is a standard 40-watt appliance bulb. Before replacing, make sure the oven and cooktop are cool and the control knobs are in the off position.

To Replace:

1. Unplug range or disconnect power.
2. Turn the glass bulb cover in the back of the oven counterclockwise to remove.

3. Turn bulb counterclockwise to remove from socket.
4. Replace bulb, then bulb cover by turning clockwise.
5. Plug in range or reconnect power.

TROUBLESHOOTING

WARNING - Electrical Shock Hazard: Plug into a grounded 3 prong outlet. Do not remove ground prong. Do not use an adapter. Do not use an extension cord. Failure to follow these instructions can result in death, fire, or electrical shock.

PROBLEM	POSSIBLE CAUSES	SOLUTIONS
Nothing will operate	Power supply cord is unplugged.	Plug into a grounded 3 prong outlet.
	Energy Save is active, and the display is blank.	Press any key on the control to display See the “Electronic Oven Controls” section for more information.
	Household fuse is blown or a circuit breaker is tripped.	Replace the fuse or reset the circuit breaker. If the problem continues, call an electrician.
	Main or regulator gas shutoff valve is in the off position.	See the Installation Instructions.
	The range is improperly connected to the gas supply.	Contact a trained repair specialist or see the Installation Instructions.
Surface burners will not operate	The control knob is not set correctly.	Push in knob before turning to a setting.
	Air in the gas lines	If this is the first time the surface burners are used, turn on any one of the surface burners for a few minutes to release air from the gas lines.
	Clogged burner ports	See “Sealed Surface Burners” section.
Surface burner flames are uneven, yellow and/or noisy	Clogged burner ports	See “Sealed Surface Burners” section.
	Burner caps positioned improperly	See “Sealed Surface Burners” section.
	Range converted improperly	If propane gas is being used, contact a service technician or see cover for contact information.
Excessive heat around cookware on cooktop	Cookware and flame are not matched.	The cookware should be centered above the burner. The bottom sitting level on the grate. The cookware should be adjusted so that it does not extend up the sides of the pan.
Cooktop cooking results not what expected	Improper cookware	Ideal cookware should have a flat bottom and a well fitting lid, and the material should be of medium to heavy thickness.

	Control knob set to incorrect heat level	See “Cooktop Use” section.
	Range is not level	Level the range. See the Installation Instructions.
Oven will not operate	Air in the gas lines	If this is the first time the oven has been installed, turn any one of the surface burner knobs to the ON position to purge the gas lines.
	Control is locked.	Press and hold START for 3 seconds to unlock.
	Control is in Demo Mode.	Press and hold DELAY START for 10 seconds to exit Demo Mode.
	Electronic oven control set incorrectly	See “Electronic Oven Controls” section.
Oven burner flames are yellow or noisy	Range converted improperly	If propane gas is being used, contact a qualified technician or see cover for contact information.
Oven temperature too high or too low	Oven temperature needs adjustment.	See “Oven Temperature Control” in the “Electronic Oven Controls” section.
Convection fan not working	The convection cycle is in the first 5 minutes of operation.	This is normal. The convection fan will stop approximately 5 minutes into the cycle.
	Oven door is open.	If the oven door is opened during convection, the fan will turn off immediately. It will continue to run when the oven door is closed.
Display shows messages	Power failure (display shows flashing time)	Clear the display. On some models, reset is needed. See “Clock” keypad feature in the “Electronic Oven Controls” section of the “User’s Guide” section.
	Error code (display shows letter followed by number)	Depending on your model, press CANCEL to clear the display. See “Control Display” in the “Electronic Oven Controls” section. If it reappears, call for service or see cover for contact information.
	Start needs to be pressed so a cycle can begin (display shows “PUSH” or “PSH”).	See the “Start” keypad feature in the “Electronic Oven Controls” section.
		Press CANCEL to exit Sabbath Mode.



	Range is in Sabbath Mode (display shows “SAb”).	
Clean cycle did not work on all spills	Several cooking cycles between Clean cycles or spills on oven walls and doors	Run additional Clean cycles. Use the Affresh™ Technology Cleaning Kit. Use affresh™™ Appliance Cleaner or affresh™™ Cooktop Cleaner. See the “Accessories” and “Clean Cycle” section for more information.
Mineral deposits are left on the oven bottom after the Clean cycle	Tap water was used in the Clean cycle.	Use distilled or filtered water in the Clean cycle. To remove deposits, use a cloth soaked in white vinegar. Then use a cloth dampened with water to remove any vinegar residue.
	Range is not level.	Mineral deposits will collect on dry areas on the oven bottom during the Clean cycle. Level the range. See the Installation Instructions. To remove deposits, use a cloth soaked in white vinegar. Then use a cloth dampened with water to remove any vinegar residue.
Oven cooking results not what expected	Range is not level.	Level the range. See the Installation Instructions.
	The temperature set was incorrect.	Double-check the recipe in a reliable cooking source.
	Oven temperature needs adjustment.	See “Oven Temperature Control” in the “Oven Controls” section.
	Oven was not preheated.	See “Baking and Roasting” section.
	Racks were positioned improperly.	See “Positioning Racks and Bakeware” section.
	Not enough air circulation around bakeware	See “Positioning Racks and Bakeware” section.
	Darker browning of food caused by dull or dark bakeware	Lower oven temperature 25°F (15°C) or move rack to a higher position in the oven.
		Move rack to a lower position in the oven.



	Lighter browning of food caused by shiny or light colored bakeware	
	Batter distributed unevenly in pan	Check that batter is level in the pan.
	Incorrect length of cooking time was used.	Adjust cooking time.
	Oven door was not closed.	Be sure that the bakeware does not keep closing.
	Oven door was opened during cooking.	Oven peeking releases oven heat and causes longer cooking times.
	Rack is too close to bake burner, making baked items too brown on bottom.	Move rack to higher position in the oven.
	Pie crusts browning too quickly	Use aluminum foil to cover the edge of pie to reduce baking temperature.

Noises

PROBLEM	POSSIBLE CAUSES	SOLUTIONS
Surface burner making popping noises	Wet burner	Allow it to dry.
Gas range noises during Bake and Broil operations The following are some normal sounds with the explanations.	These sounds are normal operational noises that can be heard each time the Bake or Broil burners ignite during the cycle.	
Pop	Gas valve is opening or cycling on and will make a single pop when it snaps open from the solenoid. It sounds similar to a suction cup being pulled off of a piece of glass.	This is normal.

Click	The igniters will click several times until the flame is detected. These are short clicking sounds like tapping a nail onto a piece of glass.	This is normal.
	Convection fan relay is cycling on and off (on some models).	This is normal.
Woosh or poof	Bake or Broil burner is igniting.	This is normal.
Oven burner flames are yellow or noisy	Range converted improperly	If propane gas is being used, contact a technician or see cover for contact info

Warning

This content is compiled from multiple sources and is provided for reference purposes only. It may not be complete or fully applicable to all situations. If you are unable to resolve your issue, please contact the product manufacturer or an authorized service provider for official support.

