

Use & Care Guide for Refrigerator

FEATURES AT A GLANCE

Features may vary according to model

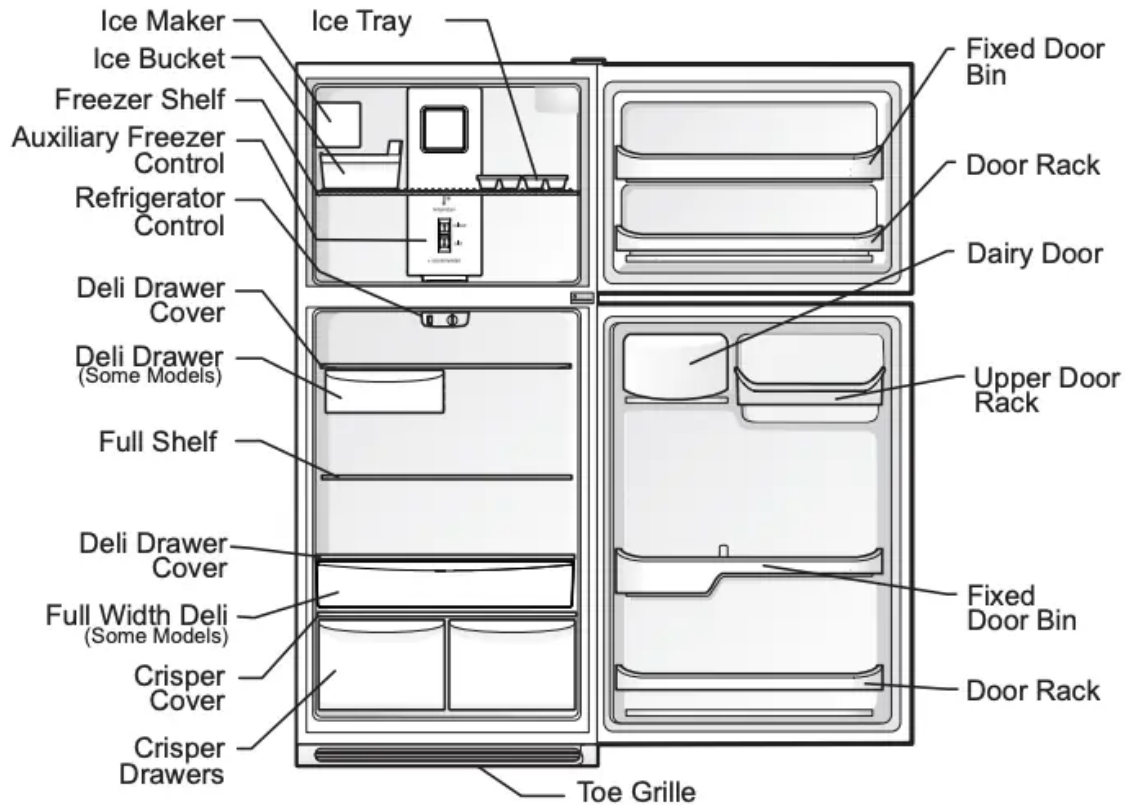

IMPORTANT

Cleaning your Refrigerator

Remove tape and glue residue from surfaces before turning on the refrigerator. Rub a small amount of liquid dish soap over the adhesive with your fingers. Rinse with warm water and dry with a soft cloth.

Do not use sharp instruments, rubbing alcohol, flammable fluids, or abrasive cleaners to remove tape or glue. These products can damage the surface of your refrigerator.

After you remove all of the package materials, clean the inside of your refrigerator before using it. See the “Care & Cleaning” section in this manual.

See important information about cleaning glass shelves and covers in the “Optional Features” section of this manual.

IMPORTANT

Moving your Refrigerator

Your refrigerator is heavy. When moving the refrigerator for cleaning or service, be sure to cover the floor with cardboard or hardboard to avoid floor damage. Always pull the refrigerator straight out when moving it. Do not wiggle or “walk” the refrigerator when trying to move it as floor damage could occur.

ICE SERVICE

If your refrigerator has an automatic ice maker, minimal ice will be produced during the first 24 hours of operation. Air in new plumbing lines may cause the ice maker to cycle two or three times before making a full tray of ice. With no usage, it will take approximately one to two days to fill the ice container.

New plumbing connections may cause the first production of ice cubes to be discolored or have an odd flavor. Discard ice made during the first 24 hours.

NOTE

Automatic ice makers are also optional accessories that may be installed in most models at any time. Call your local dealer for information.

Turning your Ice Maker On

After the plumbing connections have been completed, the water supply valve must be opened. Place the ice container under the ice maker, pushing it as far back as possible. Lower the wire signal arm to its “down” or ON position.

Turning your Ice Maker Off

To stop the ice maker, lift the wire signal arm until it clicks and locks in the “up” or OFF position. The ice maker also turns off automatically when the ice container is full.

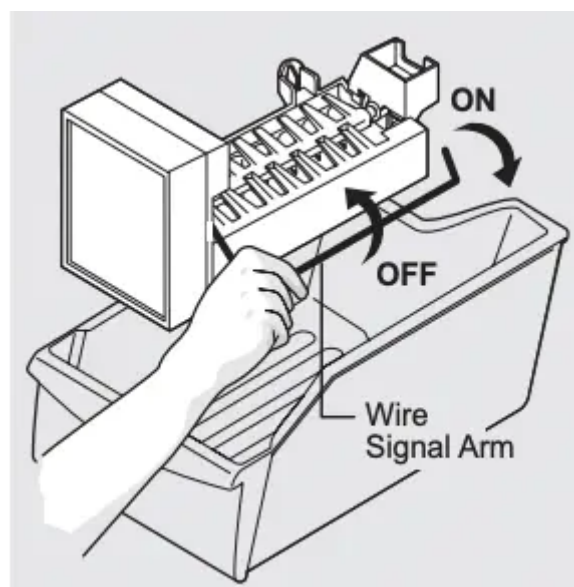

IMPORTANT Your ice maker is shipped from the factory with the wire signal arm in the ON position. To ensure proper function for your ice maker, hook up water supply immediately or turn ice maker OFF by lifting the wire signal arm until it clicks and locks in the UP position. If the ice maker is on and the water supply is not connected, the water valve will make a loud chattering noise.

ICE PRODUCTION: WHAT TO EXPECT

The ice maker will produce 2.5 to 3 pounds of ice every 24 hours depending on usage conditions. Ice is produced at a rate of 8 cubes every 80 to 160 minutes.

CAUTION Do Not place the ice container in your dishwasher.

CONTROLS

Cool Down Period

To ensure safe food storage, allow the refrigerator to operate with the doors closed for at least 8 hours before loading it with food.

Refrigerator & Freezer Controls

NOTE When first turning refrigerator on, adjust control to recommended. This is the recommended initial setting. After 24 hours, adjust the controls as needed.

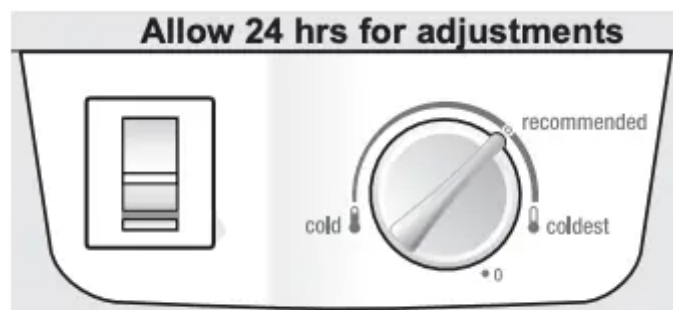

Refrigerator Control

IMPORTANT Adjusting the refrigerator temperature control to "0" turns off the compressor and prevents the refrigerator from cooling, but does not disconnect the power to the light bulb and other electrical components. To turn off power to your refrigerator, you must unplug the power cord from the wall outlet.

Temperature Adjustment

- Adjust temperature gradually: adjust the knob in small increments, allowing the temperature to stabilize.
- For colder temperatures, adjust the knob towards coldest.

- For warmer temperatures, adjust the knob towards cold.

Adjusting the refrigerator control will change temperatures in both compartments. The auxiliary freezer control can be left at the factory pre-set (mid position) or adjusted as desired; it has no effect on electrical power to the refrigerator.

To maintain temperatures, a fan circulates air in the refrigerator and freezer compartments. For good circulation, do not block cold air vents with food items.

CAUTION

Do not install the refrigerator where the temperature will drop below 55°F (13°C) or rise above 110°F (43°C). The compressor will not be able to maintain proper temperatures inside the refrigerator.

IMPORTANT

If you install your refrigerator in a garage or other unheated area, you may experience freezer temperature problems during the winter months when temperatures dip below 55° F. Upgrading your refrigerator with a Garage Kit will lower the minimum operating temperature of your unit to 34° F. This kit can be ordered by calling the phone number listed at the bottom of the warranty page or back cover at an additional cost.

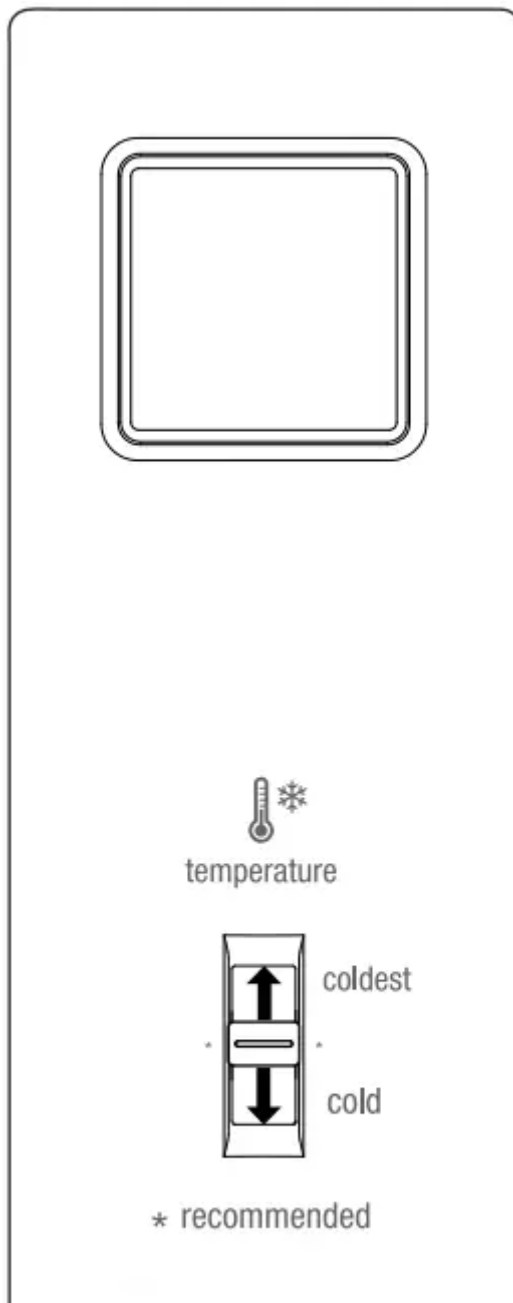

Auxiliary Freezer Control

OPTIONAL FEATURES

CAUTION

Do not clean glass shelves or covers with warm water when they are cold. Shelves and covers may break if exposed to sudden temperature changes or impact, such as bumping. Tempered glass is designed to shatter into many small, pebble-size pieces. This is normal. Glass shelves and covers are heavy. Use both hands when removing them to avoid dropping.

CAUTION

To avoid personal injury or property damage, handle tempered glass shelves carefully. Shelves may break suddenly if nicked, scratched, or exposed to sudden temperature change.

Shelf Adjustment

Refrigerator shelves are easily adjusted to suit individual needs. Before adjusting the shelves, remove all food.

To adjust sliding shelves:

1. Remove shelf by pulling forward to stop position.
2. Lift front edge up and pull out.

To replace shelf, rest side edges on any pair of shelf rails and carefully push shelf back into position.

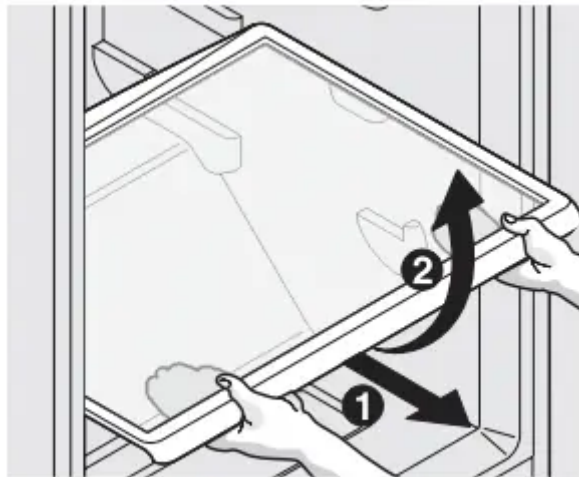

Sliding Glass Shelf

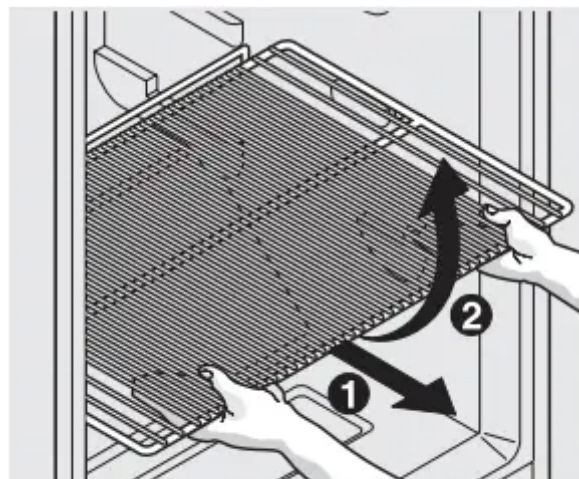

Sliding Wire Shelf

Door storage

Door bins, shelves, and racks are provided for convenient storage of jars, bottles, and cans.

Frequently used items can be quickly selected.

The dairy compartment, which is warmer than the general food storage section, is intended for short term storage of cheese, spreads, or butter.

Door rack

Some models have door racks or bins that can accommodate gallon-sized plastic drink containers and economy-sized jars and containers.

To remove door rack:

1. Push on rack sides to release from locking tabs.
2. Pull straight out.

To install door rack:

1. Push rack straight ahead.
2. You will hear the sides lock into the tabs.

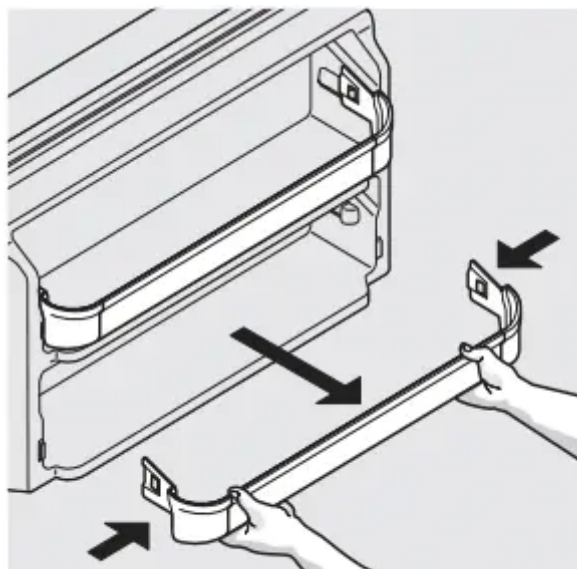

Door Rack

Crisper Humidity Control (some models)

The crisper humidity control, present on the crisper drawers of some models, allows you to adjust the humidity within the crisper. This can extend the life of fresh vegetables that keep best in high humidity.

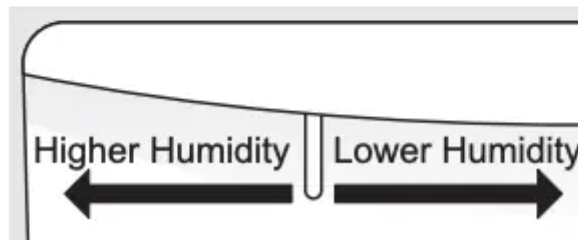
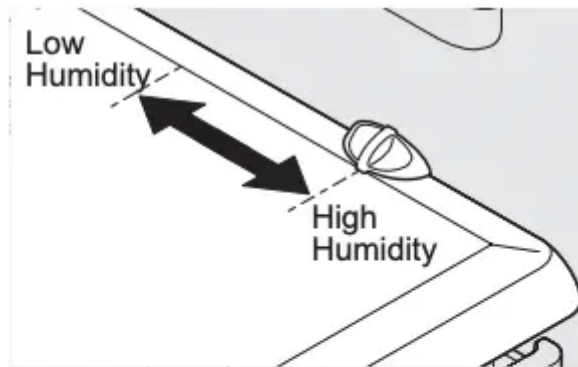

NOTE Leafy vegetables keep best when stored with the Humidity Control set on High Humidity, or in a drawer without a Humidity Control. This keeps incoming air to a minimum and maintains maximum moisture content. Store non-leafy vegetables and fruits still in their skins at the low humidity setting

Crispers (some models)

The crispers, located under the bottom refrigerator shelf, are designed for storing fruits, vegetables, and other fresh produce. Wash items in clear water and remove excess water before placing them in the crispers. Items with strong odors or high moisture content should be wrapped before storing.

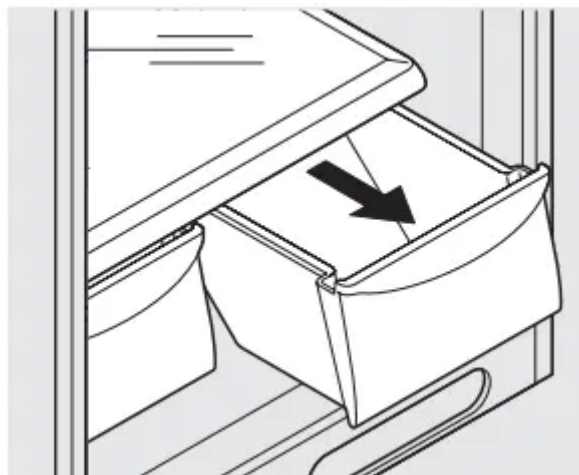

NORMAL OPERATING SOUNDS AND SIGHTS

Understanding the sounds you may hear

Your new, high-efficiency refrigerator may introduce unfamiliar sounds. These sounds normally indicate your refrigerator is operating correctly. Some surfaces on floors, walls, and kitchen cabinets may make these sounds more noticeable.

NOTE Rigid foam insulation is very energy efficient, but is not a sound insulator.

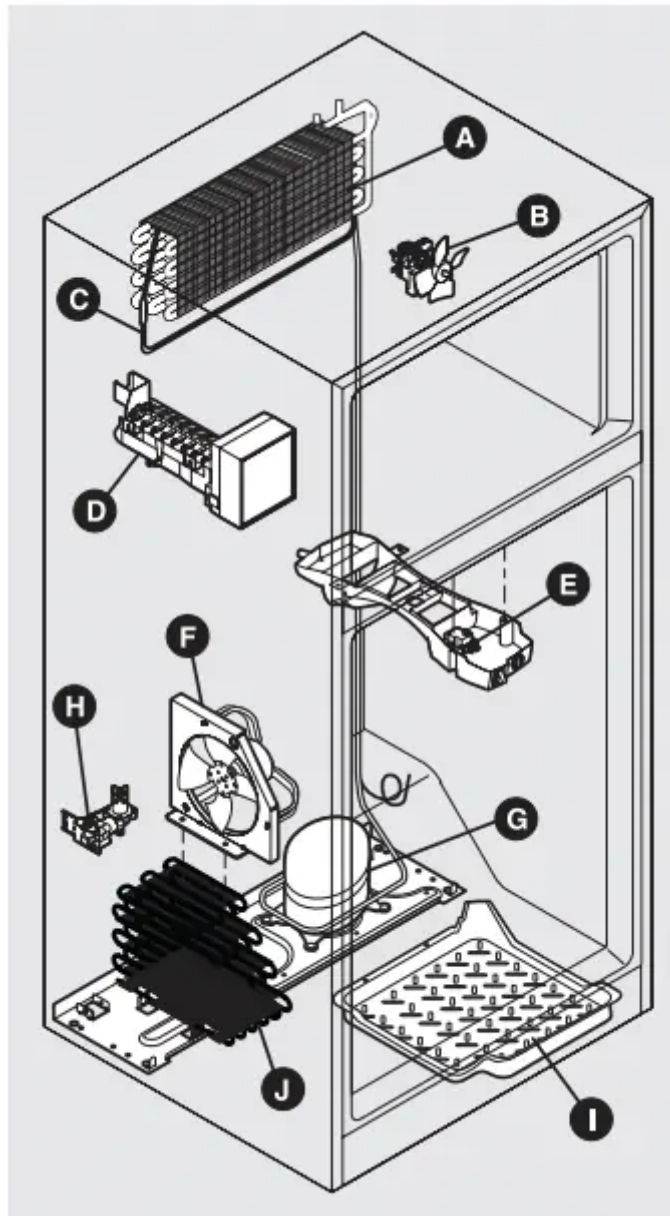

Following is a list of major components in your refrigerator and the sounds they can cause:

A Evaporator Refrigerant through the evaporator may create a boiling or gurgling sound.

B Evaporator fan You may hear air being forced through the refrigerator by the evaporator fan.

C Defrost heater During defrost cycles, water dripping onto the defrost heater may cause a hissing or sizzling sound. After defrosting, a popping sound may occur.

IMPORTANT During the automatic defrost cycle, you may notice a red glow in the vents on the back wall of your freezer compartment. This is normal during the defrost cycle.

D Automatic ice maker When ice has been produced, you will hear ice cubes falling into the ice bin.

E Automatic Defrost control These parts can produce a snapping or clicking sound when turning the cooling system on and off.

F Condenser fan You may hear air being forced through the condenser.

G Compressor Modern, high-efficiency compressors run much faster than in the past. The compressor may have a highpitched hum or pulsating sound.

H Water valve If your refrigerator is equipped with an automatic ice maker, you will hear a buzzing sound as the water valve opens to fill the ice maker during each cycle.

I Drain pan (not removable) You may hear water dripping into the drain pan during the defrost cycle.

J Condenser May create minimal sounds from forced air.

CARE & CLEANING

Protecting your investment

Keeping your refrigerator clean maintains appearance and prevents odor build-up. Wipe up any spills immediately and clean the freezer and fresh food compartments at least twice a year. When cleaning, take the following precautions:

- Never use CHLORIDE or cleaners with bleach to clean stainless steel.
- Do not wash any removable parts in a dishwasher.
- Always unplug the electrical power cord from the wall outlet before cleaning.
- Remove adhesive labels by hand. Do not use razor blades or other sharp instruments which can scratch the appliance surface.
- Do not remove the serial plate.

Do not use abrasive cleaners such as window sprays, scouring cleansers, brushes, flammable fluids, cleaning waxes, concentrated detergents, bleaches or cleansers containing petroleum products on plastic parts, interior doors, gaskets or cabinet liners. Do not use paper towels, metallic scouring pads, or other abrasive cleaning materials or strong alkaline solutions.

NOTE If you set your temperature controls to turn off cooling, power to lights and other electrical components will continue until you unplug the power cord from the wall outlet.

CAUTION

- Pull the refrigerator straight out to move it. Shifting it from side to side may damage flooring. Be careful not to move the refrigerator beyond the plumbing connections.
- Damp objects stick to cold metal surfaces. Do not touch refrigerated surfaces with wet or damp hands.

IMPORTANT If you store or move your refrigerator in freezing temperatures, be sure to completely drain the water supply system. Failure to do so could result in water leaks when the refrigerator is put back into service. Contact a service representative to perform this operation.

Care & Cleaning Tips		
Part	What To Use	Tips and Precautions
Interior & Door Liners	<ul style="list-style-type: none"> • Soap and water • Baking soda and water 	Use 2 tablespoons of baking soda in 1 quart of warm water. Be sure to wring excess water out of sponge or cloth before cleaning around controls, light bulb or any electrical part.
Door Gaskets	<ul style="list-style-type: none"> • Soap and water 	Wipe gaskets with a clean soft cloth.
Drawers & Bins	<ul style="list-style-type: none"> • Soap and water 	Use a soft cloth to clean drawer runners and tracks.
Glass Shelves	<ul style="list-style-type: none"> • Soap and water • Glass cleaner • Mild liquid sprays 	Allow glass to warm to room temperature before immersing in warm water.
Toe Grille	<ul style="list-style-type: none"> • Soap and water • Mild liquid sprays • Vacuum attachment 	Vacuum dust from front of toe grille. Remove toe grille (see Installation Instructions). Vacuum backside, wipe with sudsy cloth or sponge. Rinse and dry.
Exterior & Handles	<ul style="list-style-type: none"> • Soap and water • Non Abrasive Glass Cleaner 	Do not use commercial household cleaners containing ammonia, bleach or alcohol to clean handles. Use a soft cloth to clean smooth handles. DO NOT use a dry cloth to clean smooth doors.
Exterior & Handles (Stainless)	<ul style="list-style-type: none"> • Soap and water 	Never use CHLORIDE or cleaners with bleach to clean stainless steel.

<p>Steel Models Only)</p>	<ul style="list-style-type: none"> • Stainless Steel Cleaners 	<p>Clean stainless steel front and handles with nonabrasive soapy water and a dishcloth. Rinse with clean water and a soft cloth. Use a non-abrasive stainless steel cleaner. These cleaners can be purchased at most home improvement or major department stores. Always follow manufacturer's instructions. Do not use household cleaners containing ammonia or bleach.</p> <p>NOTE: Always clean, wipe and dry with the grain to prevent scratching. Wash the rest of the cabinet with warm water and mild liquid detergent. Rinse well, and wipe dry with a clean soft cloth.</p>
<p>Replacing Light Bulbs</p>	<ul style="list-style-type: none"> • Unplug refrigerator • Wear gloves • Remove light cover (some models) • Replace old bulb • Replace light cover (some models) • Plug in the refrigerator 	<p>CAUTION: Wear gloves when replacing light bulbs to avoid getting cut. Use same wattage when replacing bulb</p>



BEFORE YOU CALL

<p>Common Occurrences</p>	<p>Before calling for service, review this list. It may save you time and expense. This list includes common occurrences that are not the result of defective workmanship or materials in this appliance.</p>
<p>Refrigerator does not run.</p>	<ul style="list-style-type: none"> • Ensure plug is tightly pushed into electrical outlet. • Check/replace fuse with a 15 amp time-delay fuse. Reset circuit breaker. • The refrigerator/freezer control is turned to “0” • Refrigerator may be in defrost cycle. Wait 20 minutes and check again.
<p>Freezer temperature is colder than preferred. Refrigerator temperature is satisfactory.</p>	<ul style="list-style-type: none"> • Set auxiliary freezer control to a warmer setting until freezer temperature is satisfactory. Allow 24 hours for the temperature to stabilize.
<p>Refrigerator temperature is too cold. Freezer temperature is satisfactory.</p>	<p>Set refrigerator/freezer control to a warmer setting. Allow 24 hours for temperature to stabilize. Then check freezer temperatures and adjust as needed.</p>
<p>Freezer temperature is warmer than preferred. Refrigerator temperature is satisfactory.</p>	<ul style="list-style-type: none"> • Set auxiliary freezer control to a colder setting until freezer temperature is satisfactory. Allow 24 hours for the temperature to stabilize.
<p>Refrigerator temperature is too warm. Freezer temperature is satisfactory.</p>	<ul style="list-style-type: none"> • Set refrigerator/freezer control to a colder setting. Allow 24 hours for temperature to stabilize. Then check refrigerator temperatures and adjust as needed.
<p>Refrigerator is noisy or vibrates.</p>	<ul style="list-style-type: none"> • The cabinet is not level. • Floor is weak. • See Normal Operating Sounds and Sights section.
<p>Odors in refrigerator.</p>	<ul style="list-style-type: none"> • Interior needs to be cleaned. • Foods that produce odors should be covered or wrapped.



Cabinet light not working.	<ul style="list-style-type: none">• Replace light bulb.• Ensure plug is tightly pushed into electrical outlet.• Light switch may be stuck. Push in light switch, located on the refrigerator control box, to release.
Automatic ice maker not working (some models)	<ul style="list-style-type: none">• Ensure the wire signal arm is not in UP position.• Ice maker should produce 2.5 to 3 pounds of ice in a 24 hour period.• Water supply is turned off.• Water pressure is too low.• The freezer is not cold enough.

Warning

This content is compiled from multiple sources and is provided for reference purposes only. It may not be complete or fully applicable to all situations. If you are unable to resolve your issue, please contact the product manufacturer or an authorized service provider for official support.

