

INSTALLATION INSTRUCTIONS

Unpacking

WARNING

Excessive Weight Hazard Use two or more people to move and install freezer. Failure to do so can result in back or other injury.

Remove Packaging Materials

- Remove tape and glue residue from surfaces before turning on the freezer. Rub a small amount of liquid dish soap over the adhesive with your fingers. Wipe with warm water and dry.
- Do not use sharp instruments, rubbing alcohol, flammable fluids, or abrasive cleaners to remove tape or glue. These products can damage the surface of your freezer. For more information, see “Freezer Safety.”

When Moving Your Freezer:

Your freezer is heavy. When moving the freezer for cleaning or service, be sure to cover the floor with cardboard or hardboard to avoid floor damage. Always pull the freezer straight out when moving it. Do not wiggle or “walk” the freezer when trying to move it, as floor damage could occur.

Clean Before Using

After you remove all of the packaging materials, clean the inside of your freezer before using it. See the cleaning instructions in “Freezer Care.”

Important information to know about glass shelves and covers:

Do not clean glass shelves or covers with warm water when they are cold. Shelves and covers may break if exposed to sudden temperature changes or impact, such as bumping. Tempered glass is designed to shatter into many small, pebble-size pieces. This is normal. Glass shelves and covers are heavy. Use both hands when removing them to avoid dropping.

Location Requirements

WARNING

Explosion Hazard Keep flammable materials and vapors, such as gasoline, away from freezer. Failure to do so can result in death, explosion, or fire.

IMPORTANT: Check the strength of the floor before installing your freezer. It should hold the weight of a freezer fully loaded with food.

Ventilation and Clearance

- Keep flammable materials and vapors, such as gasoline, away from freezer.
- Do not cover the freezer with items such as blankets, sheets, tablecloths, etc. This reduces air circulation.
- Allow at least a 3" (7.5 cm) clearance on both sides of the freezer and 2" (5 cm) between the back of the freezer and the wall. Leave room above the freezer to open the lid.

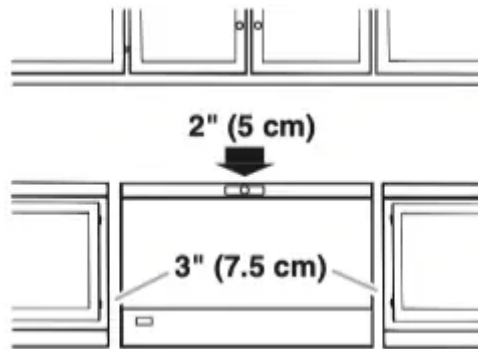

Temperature

Your freezer operates most efficiently when located in an area where the temperature is normally between 32°F (0°C) and 110°F (43°C). Do not install the freezer near an oven, radiator, or other heat source.

Upon Moving to Final Location

1. Level the freezer from side to side and front to back so that the lid will seal properly. Use shims to level the freezer if necessary.

NOTE: It should not be necessary to remove the lid during installation. If, for any reason, the hinges need adjustment, contact a designated service company.

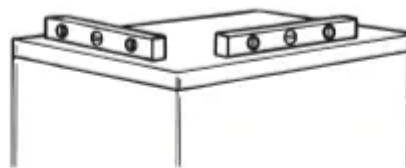

Electrical Requirements

WARNING

Electrical Shock Hazard Plug into a grounded 3 prong outlet.

Do not remove ground prong.

Do not use an adapter.

Do not use an extension cord.

Failure to follow these instructions can result in death, fire, or electrical shock.

Before you move your freezer into its final location, it is important to make sure you have the proper electrical connection.

Recommended Grounding Method

A 115 Volt, 60 Hz, AC-only, 15-amp fused and grounded (earthed) electrical supply is required.

It is recommended that a separate circuit serving only your freezer be provided. Use an outlet that cannot be turned off by a switch. Do not use an extension cord.

NOTE: Before performing any type of installation or cleaning, turn the Temperature Control to the OFF position as shown and then disconnect the freezer from the electrical source.

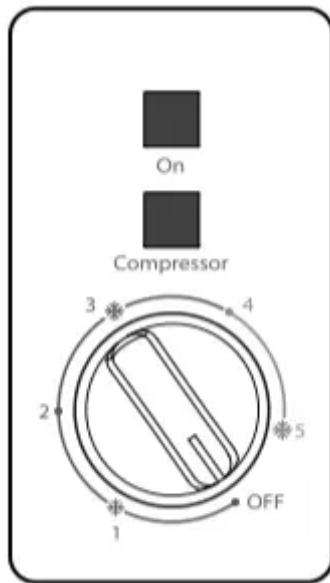

NOTE: To turn off the freezer requires moving the knob to the OFF position, place a coin on the knob carefully, and turn it down to the OFF position. (Please see the picture below).



FREEZER USE

Using the Control

Turn the freezer temperature control to 3. This setting is designed to maintain the temperature at or near 0°F (-17.8°C) under normal operating conditions.

IMPORTANT: Allow the freezer to cool 6 to 8 hours before filling with frozen food. Let the freezer cool overnight before adding large amounts of unfrozen food. Do not add more than 2 to 3 lbs (0.907 to 1.360 kg) of unfrozen food per cubic foot of freezer space.

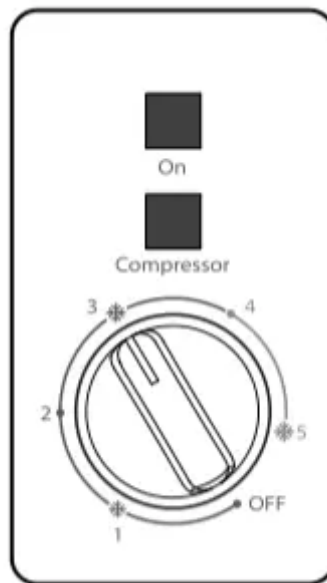

NOTES:

- When the freezer is first started, the compressor will run constantly until the interior is cooled. It may take 6 to 8 hours (or longer), depending on location, room temperature, and the number of times the freezer lid is opened.
- After the cabinet is cooled, the compressor will turn on and off as needed to keep the freezer at the proper temperature.
- Each time the lid is opened, cold air escapes and the temperature inside the freezer rises.
- The outside of your freezer may feel warm. This is normal. The freezer's design and main function is to remove heat from the contents and air inside the freezer. The heat is transferred to the room air, making the outside of the freezer feel warm.

Adjusting the Control

- Turn control to a higher number for colder temperatures.
- Turn control to a lower number for less cold temperatures.

Indicator Lights

The indicator lights are located on the front of the freezer above the control. The lights assure you that your freezer is operating. The indicator lights are LED which do not need to be replaced.

ON indicator light - shows you that there is power to the freezer.

COMPRESSOR indicator light - shows you that the compressor is running.

If the ON indicator light is not illuminated, immediately check for:

- A power interruption.
- An unplugged power cord.
- An open circuit breaker or blown fuse.

NOTE: If there is power to the freezer, and the ON indicator does not illuminate, the indicator light may be burned out. Call Service to replace the indicator lights.

If the COMPRESSOR indicator is not illuminated: the compressor is in its off cycle.

NOTE: The compressor automatically cycles off and on to maintain the desired temperature.

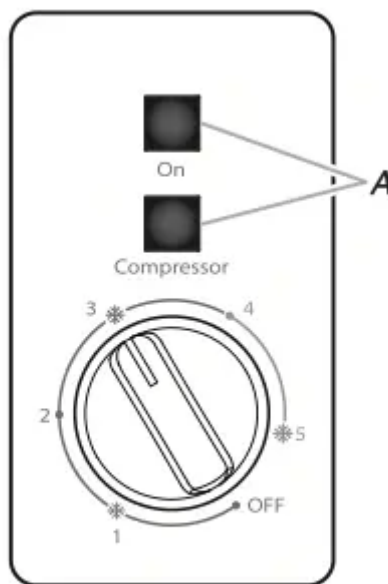

A. Indicator lights

Sliding Basket

Store small packages in the basket to avoid losing them in the bottom of the freezer. The basket can then be moved from side to side or it can be removed when loading or unloading the food below it.

To remove basket, lift it straight up and out. To replace basket, lower basket back into place.

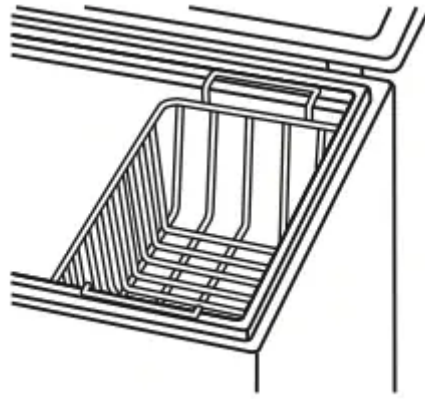

FREEZER CARE

Defrosting and Cleaning Your Freezer

WARNING

Explosion Hazard Use nonflammable cleaner.

Failure to do so can result in death, explosion, or fire.

Accumulation of frost and ice will lessen the performance of the freezer. Complete defrosting and cleaning should be done at least twice a year or when frost has built up to about ¼" (0.6 cm) thickness. In high humidity areas, a freezer may need more frequent defrosting and cleaning.

Before Defrosting

1. Turn the temperature control dial to setting 5, approximately 6 hours before defrosting, to ensure frozen food is at the lowest temperature before removing it from the freezer.
2. Remove all frozen food. Wrap frozen food in several layers of newspaper and cover with a blanket. Food will stay frozen for several hours. You may also store frozen food in a cooler, additional refrigerator-freezer, or in a cool area.
3. Remove the freezer basket and leave the lid open.

Defrosting

1. Unplug freezer or disconnect power.
2. Remove the rubber cap from the drain on the freezer floor by pulling it straight up. Set the cap aside until defrosting is completed.

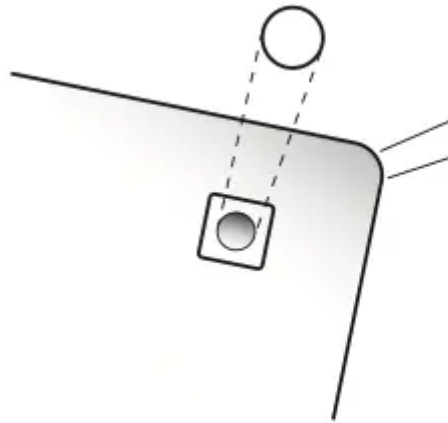

3. Place containers of warm water in the freezer, keeping the lid open, to speed melting. As the ice melts, water will collect on the bottom of the freezer.

4. Use a plastic scraper to remove frost.

NOTE: Do not use electrical appliances such as hair dryers or heaters to speed defrosting. Do not use an ice pick, knife, or other sharp-pointed tool to defrost freezer. Damage can occur.

5. Place a pan under the drain, located at the rear of the freezer. Pull the drain plug outward, extending the drain until the hole in the tube is visible.

6. Turn the drain so that the arrow is pointing downward. The defrost water will drip into the hole and flow out.

NOTE: Check the drain pan frequently to avoid water overflow. Have a second pan handy for easier emptying.



7. Wipe water from freezer walls with a towel or sponge.

8. Once no more water is draining from the freezer, push the drain back into place and turn it so the arrow is pointing upward.

Cleaning

IMPORTANT:

Do not use abrasive cleaners on your freezer. Do not use cleaning waxes, concentrated detergents, bleaches, or cleaners containing petroleum on plastic parts. Damage can occur.

Do not use water around the compressor. After defrosting and cleaning dry the compressor area thoroughly to avoid rust.

1. Wash the inside walls with a solution of mild detergent in warm water or 2 Tbs (26 mg) bakingsoda to 1 qt (0.95 L) warm water. Do not use abrasive or harsh cleaners.
2. Rinse well and wipe dry with a clean soft cloth.
3. Wash the outside of the freezer, lid liner, and gasket with a clean sponge or soft cloth and mild detergent in warm water.

NOTE: Check the lid gasket regularly to ensure it is clean and free from food particles.

4. Rinse well and wipe dry with a clean, soft cloth.
5. Wax painted metal surfaces on the outside of freezer to avoid rust.

NOTE: Do not use wax on plastic parts. Wax may damage them.

Final Steps

If you will not be using the freezer for a long period of time:

1. Replace the drain cap.
2. Do not plug in freezer or reconnect power.
3. Leave the lid ajar to avoid moisture buildup.

If you will use the freezer immediately:

1. Replace the drain cap.
2. Replace all frozen food.
3. Plug in freezer or reconnect power.
4. Turn the Temperature control to the highest number (coldest setting) for approximately 3 hours to quickly cool the freezer. Then, select your preferred temperature. See "Using the Control."

Power Interruptions

If the power will be out for 24 hours or less, keep the door closed to help food stay cold and frozen.

If the power will be out for more than 24 hours, do one of the following:

- Remove all frozen food and store it in a frozen food locker.
- If a food locker is not available, consume or can perishable food at once.

After the power is restored, unplug the freezer for 30 minutes to allow the refrigeration system to equalize. During this time, keep the door closed whenever possible.

REMEMBER: A full freezer stays cold longer than a partially filled one. A freezer full of meat stays cold longer than a freezer full of baked goods. If you see that food contains ice crystals, it may be refrozen, although the quality and flavor may be affected. If the condition of the food is poor, dispose of it.

Moving Care

When you are moving your freezer to a new home, follow these steps to prepare it for the move.

1. Remove all frozen food.
2. Unplug the freezer.
3. Take out all removable parts, wrap them well, and tape them together so they don't shift and rattle during the move.
4. Clean the freezer thoroughly.
5. Tape the freezer shut and tape the electrical cord to the cabinet.

When you get to your new home, refer to the "Installation Instructions" and "Freezer Use" sections for information on installation and setting the controls.

TROUBLESHOOTING

Try the solutions suggested here first to avoid the cost of an unnecessary service call.

Your freezer will not operate

WARNING

Electrical Shock Hazard Plug into a grounded 3 prong outlet.

Do not remove ground prong.

Do not use an adapter.

Do not use an extension cord.

Failure to follow these instructions can result in death, fire, or electrical shock.

- Is the power supply cord unplugged? Plug into a grounded 3 prong outlet.
- Has a household fuse blown or circuit breaker tripped? Replace the fuse or reset the circuit.
- Is the temperature control set to a numbered setting? Refer to the "Using the Control" section.

Indicator Lights

- Is the ON indicator not illuminated? There is no power to the freezer. Check the power source. See "Indicator Lights."
- Is there power to the freezer, but the ON indicator is not illuminated? The indicator light may be burned out. Call Service to replace the indicator light.

- Is the COMPRESSOR indicator not illuminated? The indicator illuminates only when the compressor is on. The compressor cycles off and on to maintain the desired temperature. See “Using the Control.”

The motor seems to run too much

WARNING

Explosion Hazard Use nonflammable cleaner.

Failure to do so can result in death, explosion, or fire.

- Is there excessive frost or a package keeping the door or lid from closing? Defrost and clean the freezer, or move the package so the lid closes properly.
- Is the room temperature hotter than normal? Expect the motor to run longer under warm conditions. At normal room temperatures, expect your motor to run about 40% to 80% of the time. Under warmer conditions, expect it to run even more of the time.
- Has a large amount of food just been added to the freezer? Adding a large amount of food warms the freezer. It is normal for the motor to run longer in order to cool the freezer back down. Add no more unfrozen food at one time than will freeze in 24 hours — approximately 2 to 3 lbs (0.9 to 1.4 kg) per cubic foot of freezer space.
- Is the lid opened often? Expect the motor to run longer when this occurs. In order to conserve energy, try to get everything you need out of the freezer at once, keep food organized so it is easy to find, and close the lid as soon as the food is removed.
- Is the control set correctly for the surrounding conditions? Refer to the “Using the Control” section.
- Is the lid not closed completely? Push the lid firmly shut. If it will not shut all the way, see “The lid will not close completely” later in this section.
- Is the lid gasket sealed all the way around? Contact a qualified person or a technician.
- Is there enough air circulation space around the freezer? See the “Location Requirements” section.

NOTE: If the problem is not due to any of the above, remember that your new freezer will run longer than your old one due to its high-efficiency motor.

Interior temperature is too warm

- Is the lid opened often? Be aware that the freezer will warm when this occurs. In order to keep the freezer cool, try to get everything you need out of the freezer at once, keep food organized so it is easy to find, and close the lid as soon as the food is removed.
- Has a large amount of food just been added to the freezer? Adding a large amount of food warms the freezer. It can take several hours for the freezer to return to the normal temperature.

- Is the control set correctly for the surrounding conditions? Refer to the “Using the Control” section.

Exterior of freezer feels warm

This is normal. The freezer’s main function is to remove heat from the contents and air inside the freezer. The heat is transferred to the room air, which makes the outside of the freezer feel warm.

The lid will not close completely

- Are food packages blocking the lid? Rearrange containers so that they fit more tightly and take up less space.

WARNING

Explosion Hazard Use nonflammable cleaner.

Failure to do so can result in death, explosion, or fire.

- Are the gaskets dirty or sticky? Clean gaskets according to the directions in the “Freezer Care” section.
- Does the freezer wobble or seem unstable? Level the freezer. Refer to the “Location Requirements” section.

The lid is difficult to open

WARNING

Explosion Hazard Use nonflammable cleaner.

Failure to do so can result in death, explosion, or fire.

- Are the gaskets dirty or sticky? Clean gaskets according to the directions in the “Freezer Care” section.

The freezer clicks but does not run

- Has the local power failed? Unplug the freezer for 30 minutes to allow the refrigeration system to equalize. During this time, keep the lid closed whenever possible.

Warning

This content is compiled from multiple sources and is provided for reference purposes only. It may not be complete or fully applicable to all situations. If you are unable to resolve your issue, please contact the product manufacturer or an authorized service provider for official support.

