

## PRODUCT DESCRIPTION

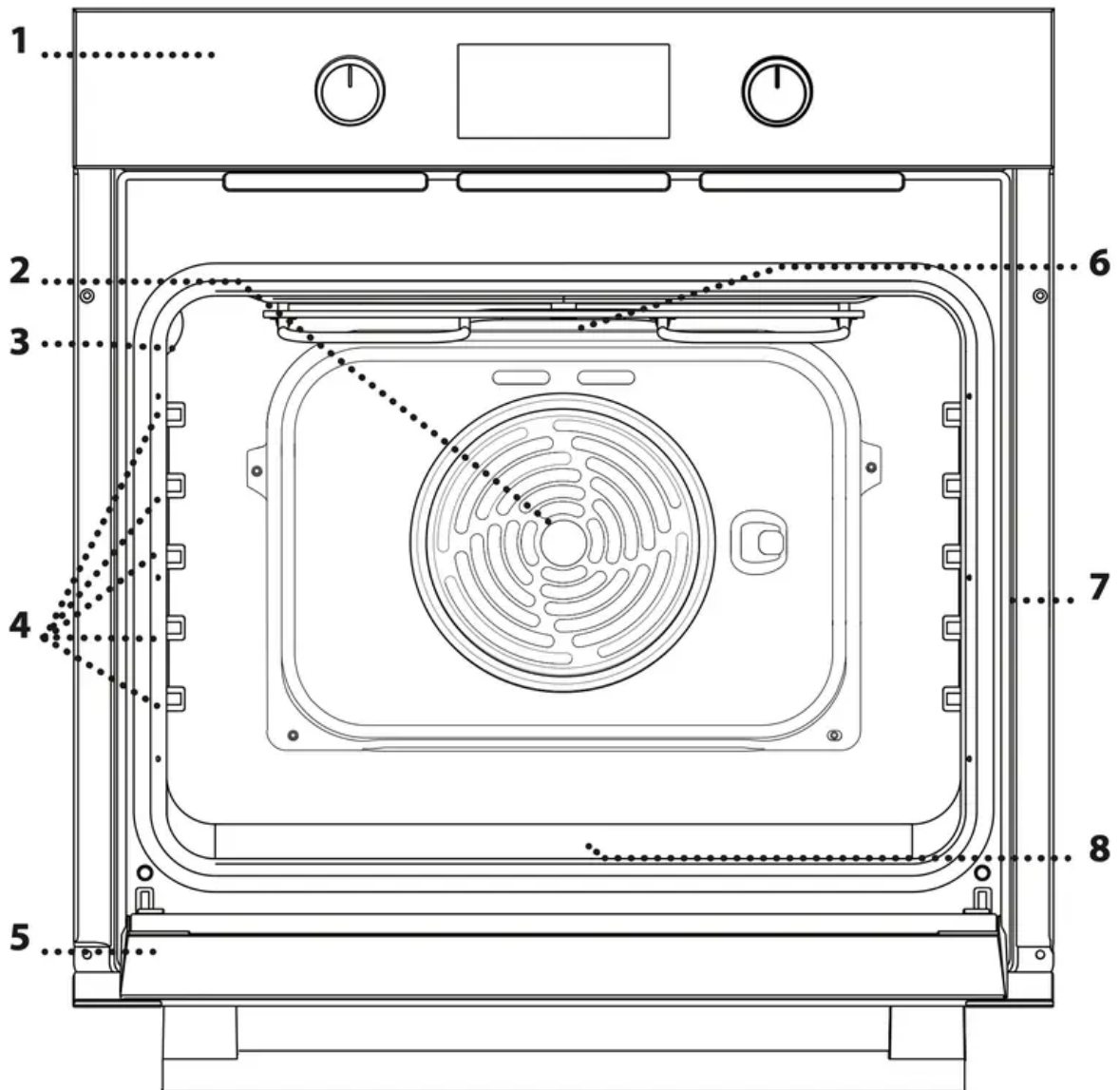

1. Control panel
2. Fan
3. Lamp
4. Runners for accessories (the level is indicated on the wall of the cooking compartment)
5. Door
6. Upper heating element/grill
7. Identification plate (do not remove)
8. Bottom heating element (non-visible)



# CONTROL PANEL

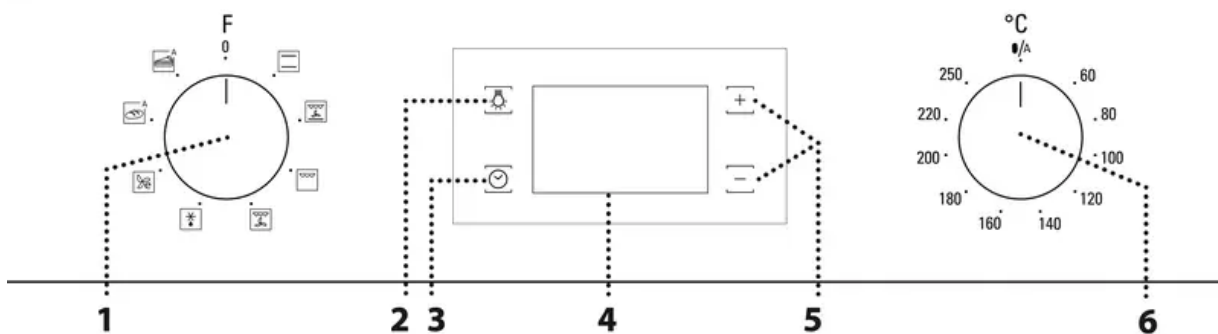

1. **SELECTION KNOB** For switching the oven on by selecting a function. Turn to the position to switch the oven off.
2. **LIGHT** With the oven switched on, press to turn the oven compartment lamp on or off.
3. **SETTING THE TIME** For accessing the cooking time settings, delayed start and timer. For displaying the time when the oven is off.
4. **DISPLAY**
5. **ADJUSTMENT BUTTONS** For changing the cooking time settings.
6. **THERMOSTAT KNOB** Turn to select the temperature you require when activating manual functions. Automatic functions use  .

## DESCRIPTION OF DISPLAY

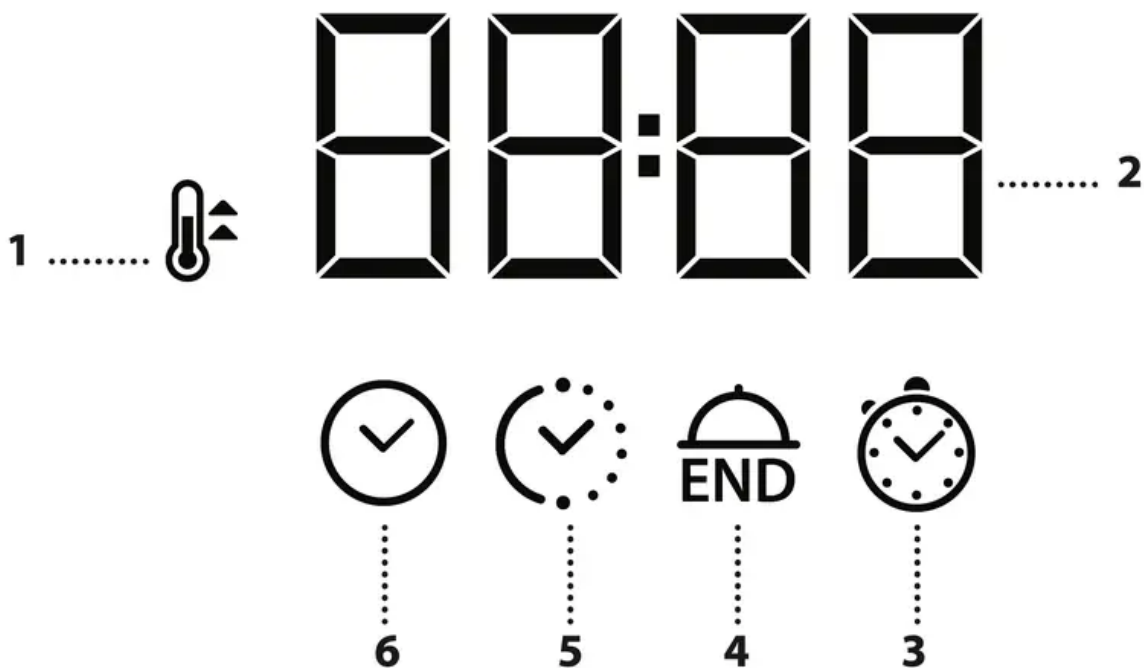

1. Preheating symbol

2. Clock; information and function duration
3. Kitchen timer
4. End of cooking time
5. Duration
6. Clock

## ACCESSORIES

### WIRE SHELF

The wire shelf can be used to grill food or as a support for pans, cake tins and other ovenproof cooking receptacles. Useful for grilling bread, meat, fish and vegetables.

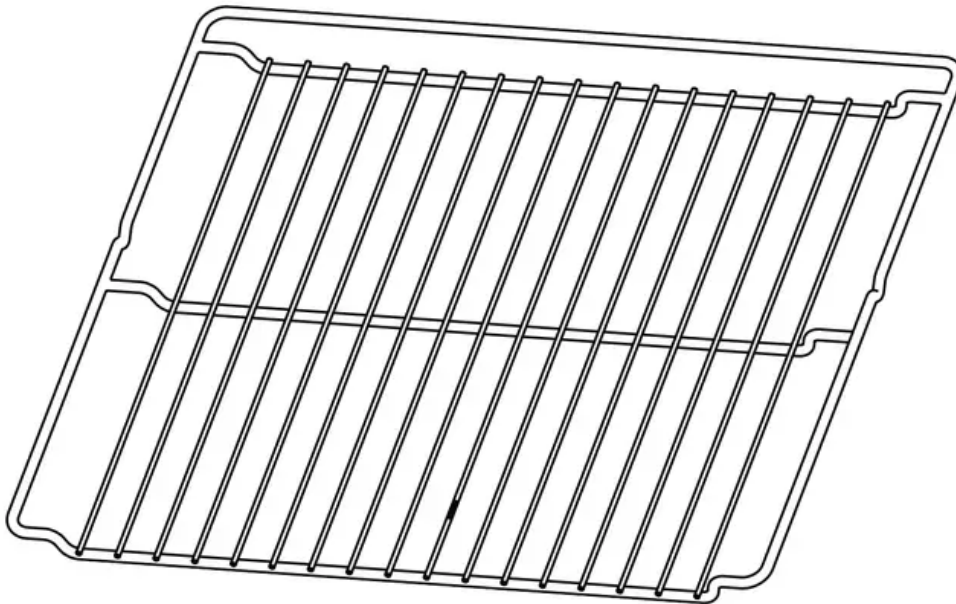

### DRIP TRAY\*

Use as an oven tray for cooking meat, fish, vegetables, focaccia, etc. or position underneath the wire shelf to collect cooking juices.

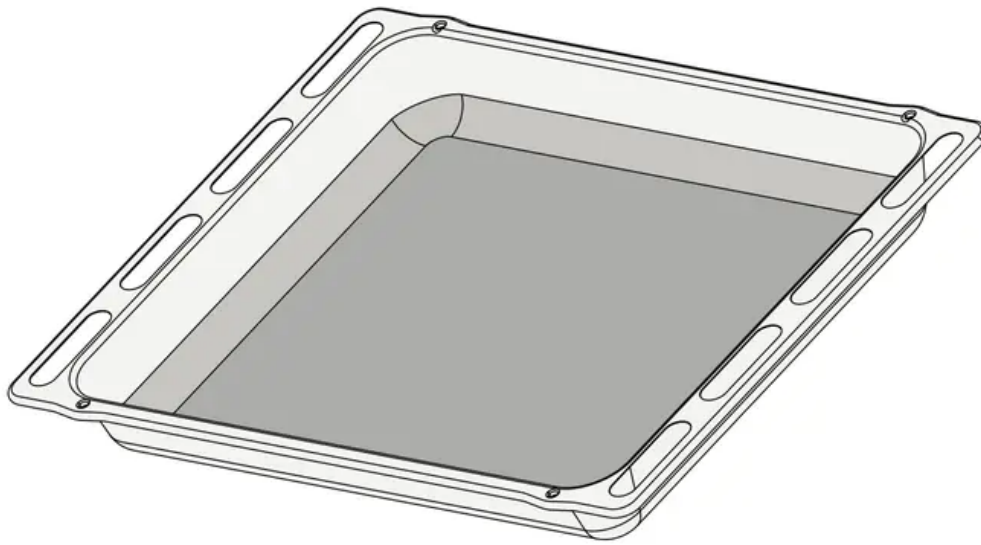

## **BAKING TRAY**

Use for cooking all bread and pastry products, but also for roasts, fish en papillote, etc.

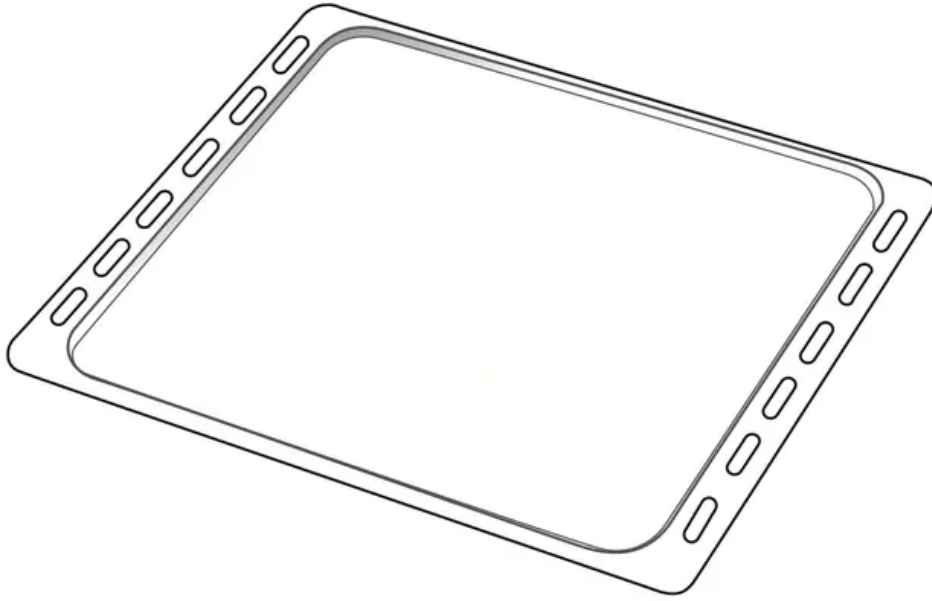

### **SLIDING RUNNERS\***

These make it easier to place accessories in and remove accessories from the oven.

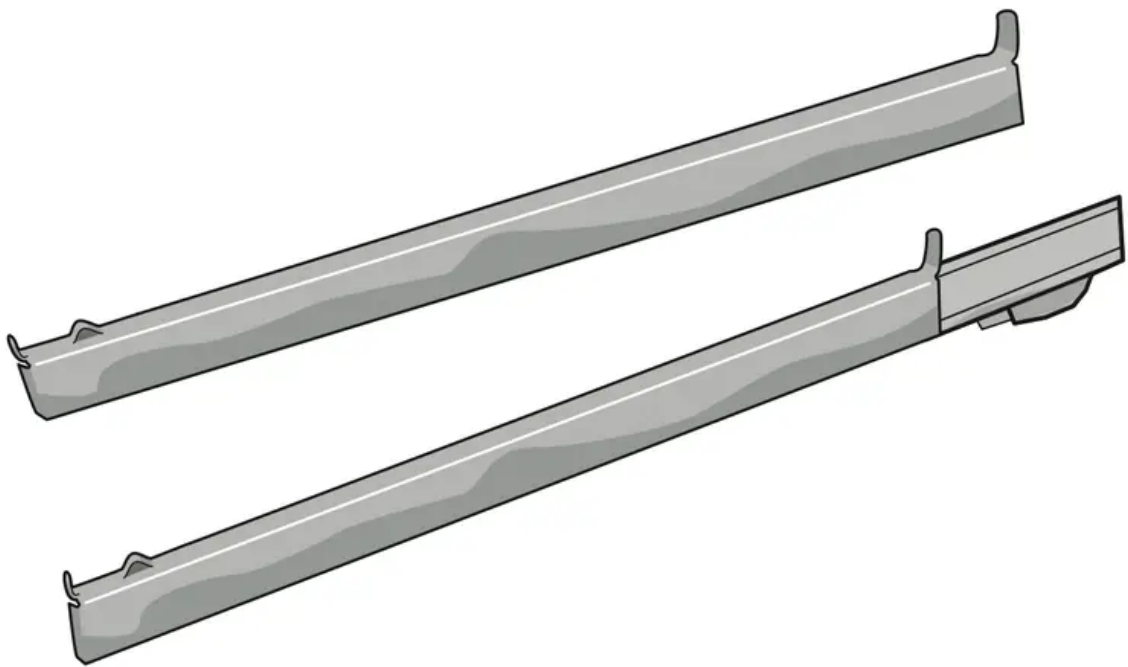

\* Available only on certain models

The number of accessories may vary depending on which model is purchased.

**ADDITIONAL ACCESSORIES:** Other accessories that are not supplied can be purchased separately from the Aftersales Service.

## **INSERTING THE WIRE SHELF AND OTHER ACCESSORIES**

- Insert the wire shelf horizontally by sliding it across the shelf guides, making sure that the side with the raised edge is facing upwards .

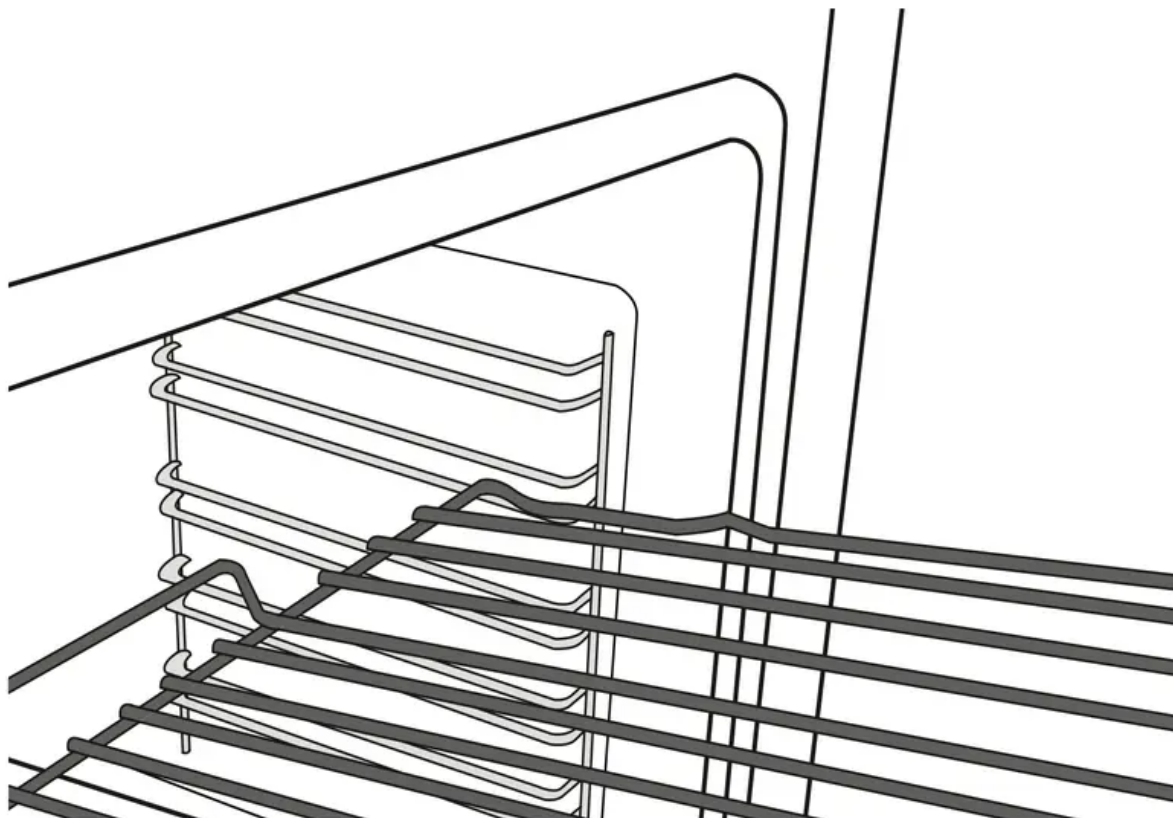

- The other accessories, such as the baking tray, are inserted horizontally in the same way as the wire shelf .

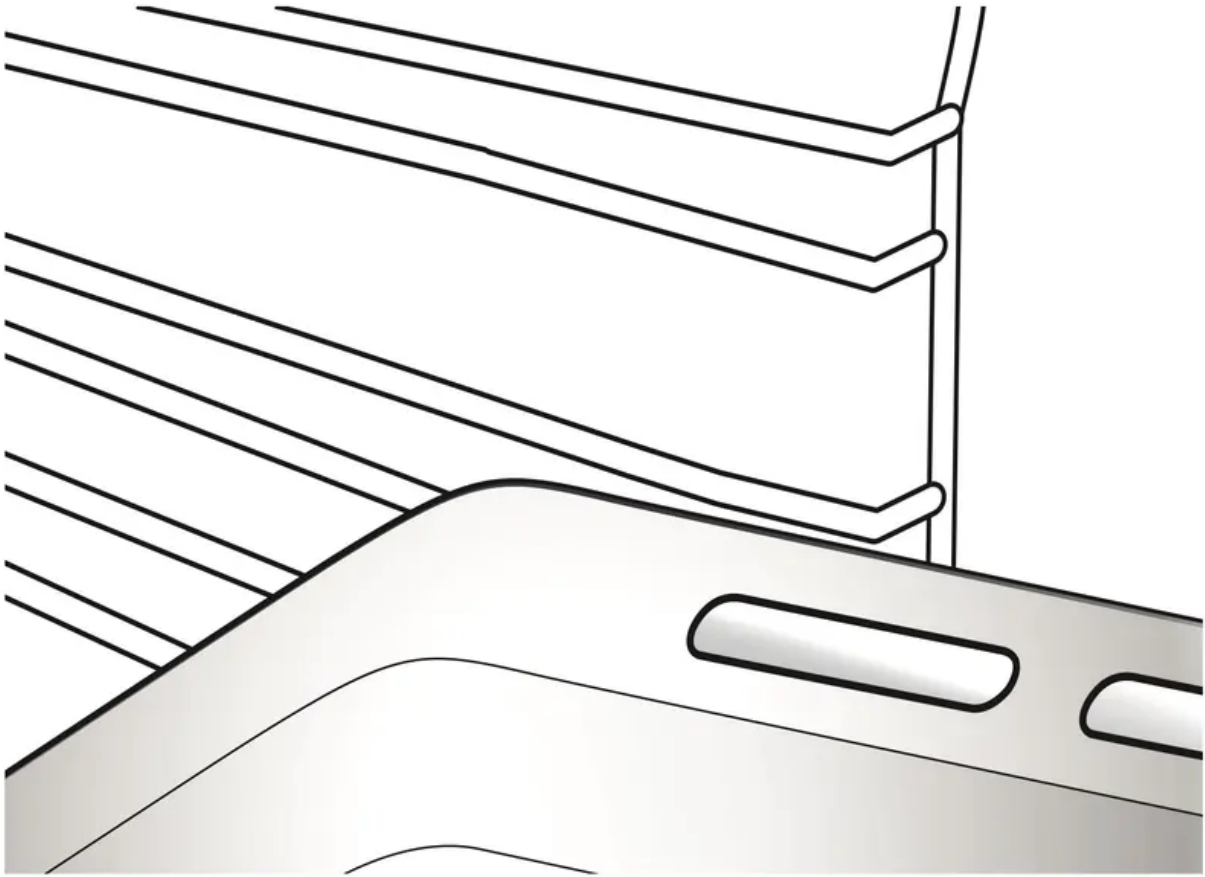

## REMOVING AND REFITTING THE SHELF GUIDES

- **To remove the shelf guides**, firmly grip the external part of the guide, and pull it towards you to extract the support and the two internal pins from the lodging .

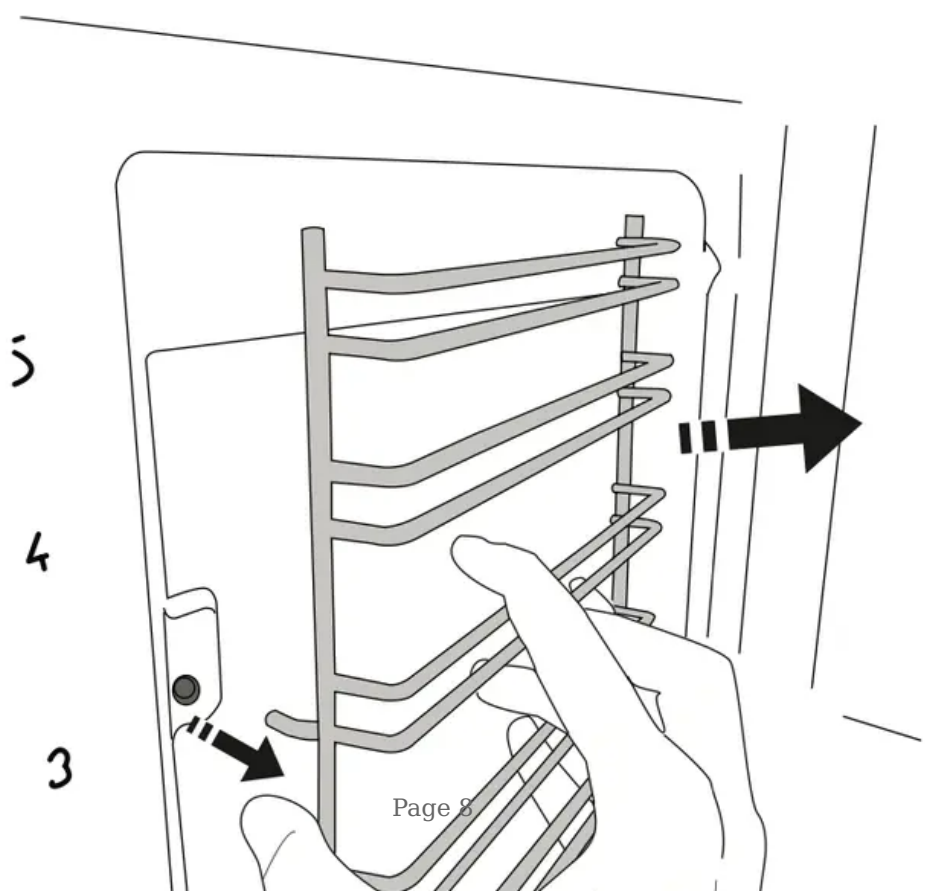
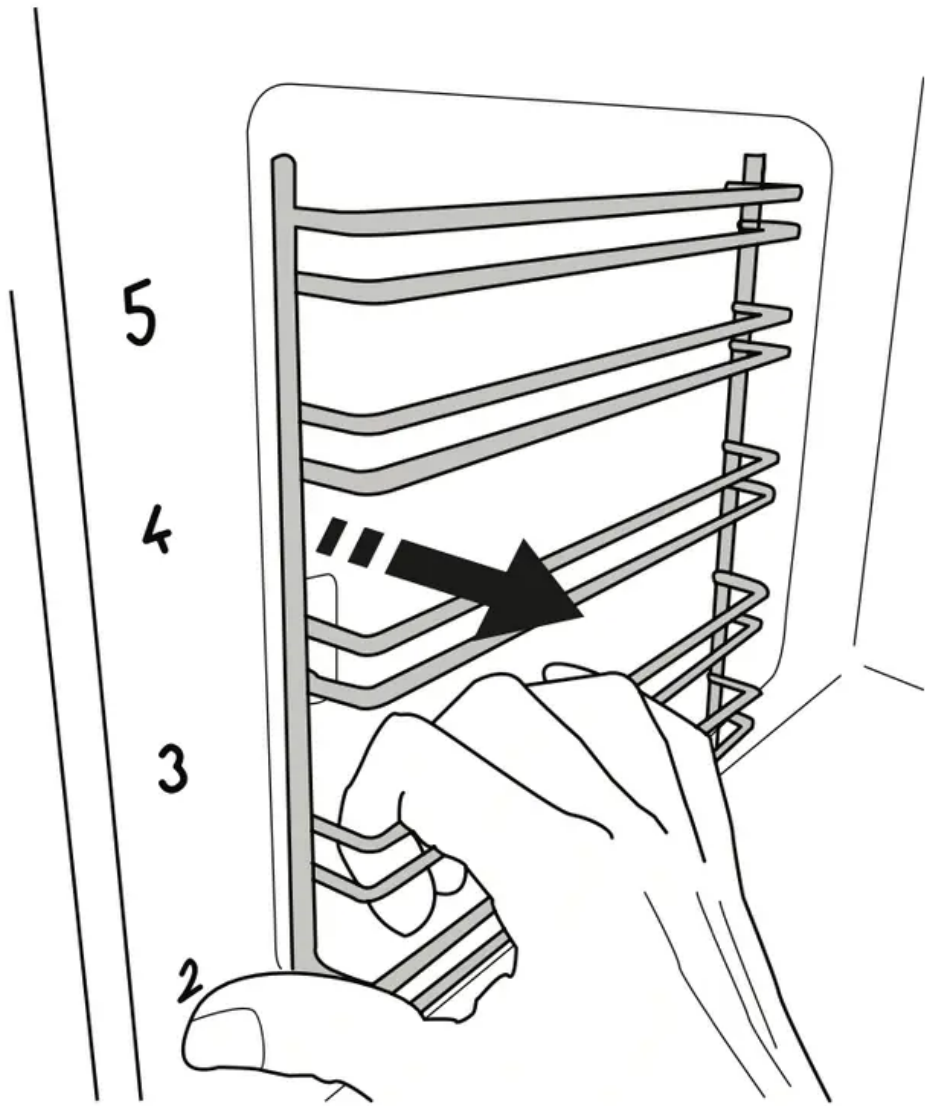

- **To reposition the shelf guides**, position them near the cavity and initially insert the two pins into their lodgings . Next, position the external part near its lodging, insert the support, and firmly press towards the wall of the cavity to make sure the shelf guide is properly secured .

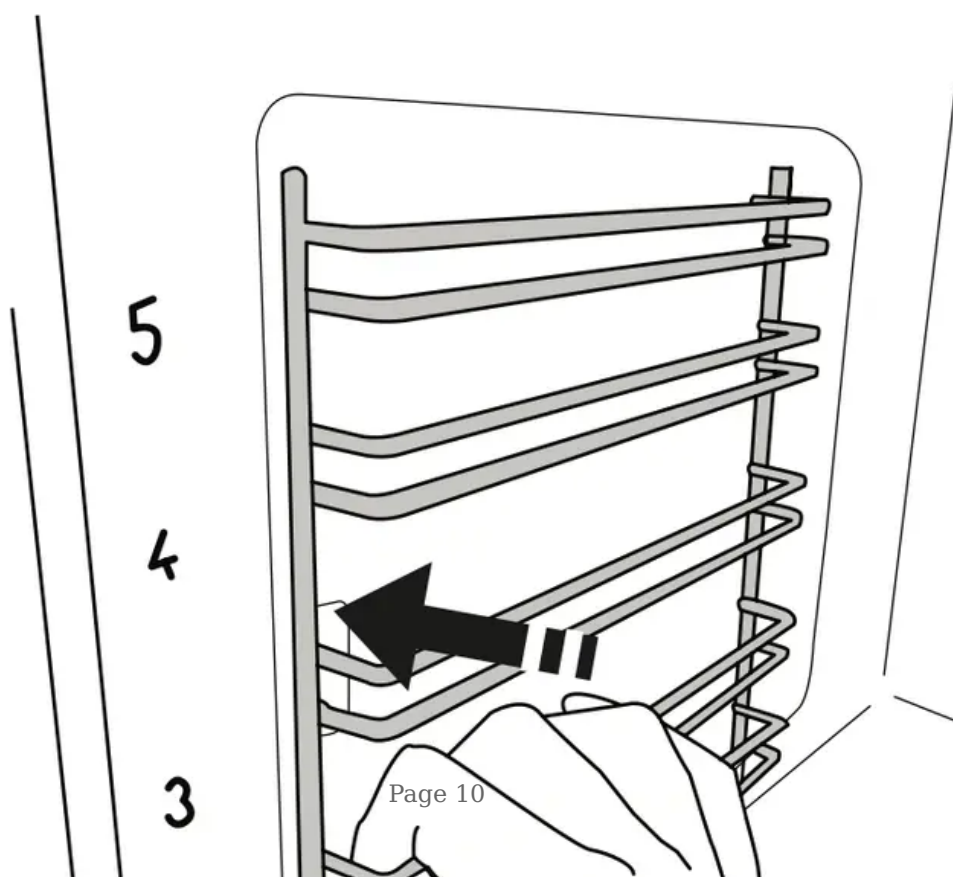
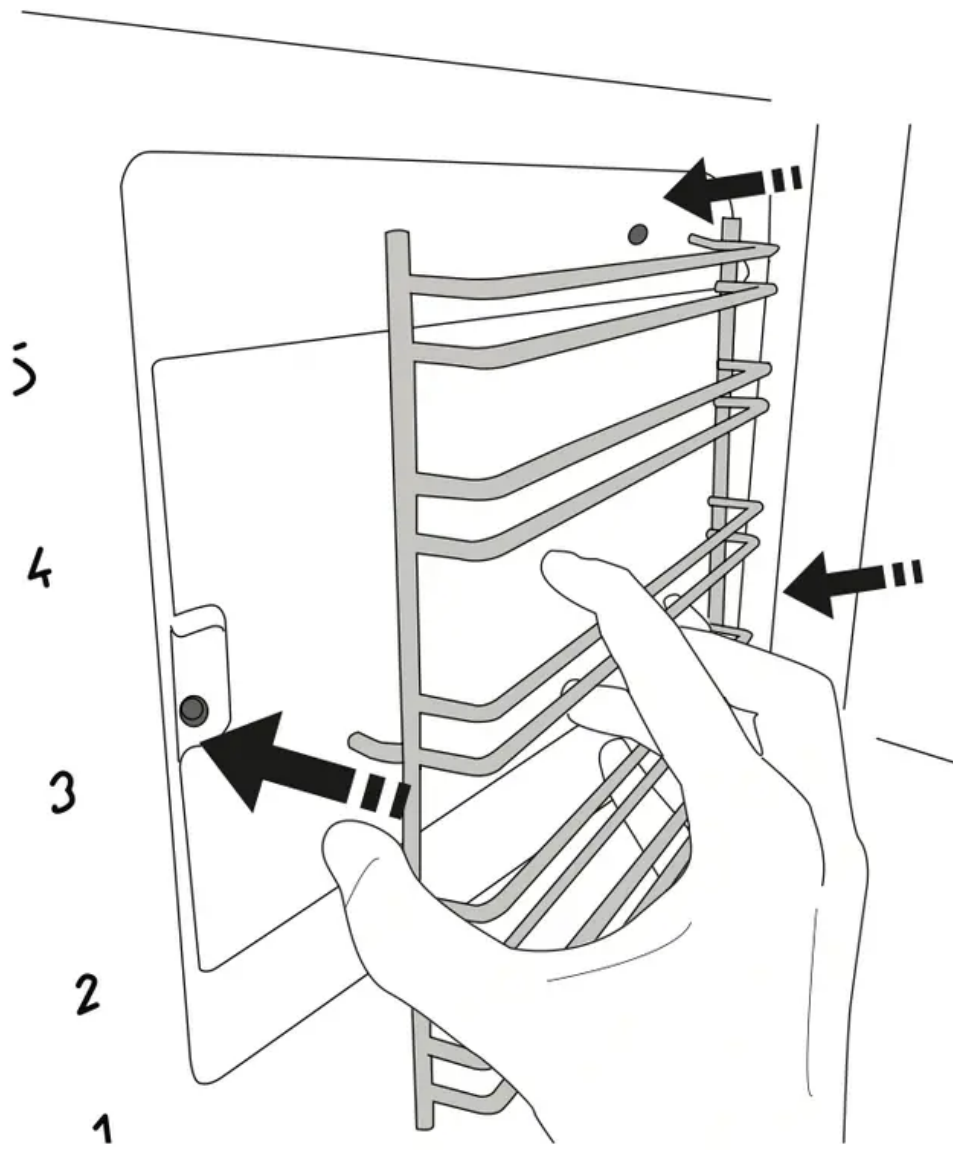

## FUNCTIONS

### CONVENTIONAL\*

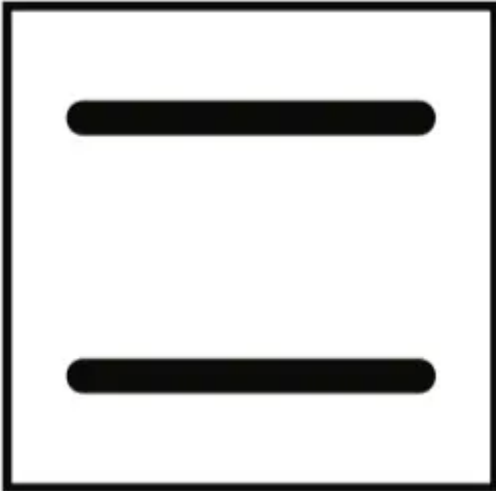

For cooking any kind of dish on one shelf only . Use the 3rd shelf . If roasting a joint of meat or cooking a pasta bake, however, use the 2nd level . Preheat the oven before placing food inside .

### CONVECTION BAKE



To cook on a maximum of two shelves at the same time. It is a good idea to swap the position of the baking trays halfway through cooking.

### GRILL



For grilling steaks, kebabs and sausages, cooking vegetables au gratin or toasting bread . We suggest placing food on the 5th shelf . When grilling meat, we recommend using a drip tray to collect the cooking juices: Position it on the 4th shelf, adding approx . 200 ml of drinking water . Preheat the oven for 3-5 minutes . The oven door must remain closed during cooking .

#### **TURBO GRILL**



For roasting large joints of meat (legs, roast beef, chicken) . Place food on the 2nd shelf . We recommend using a drip tray to collect the cooking juices: Position it on the 1st shelf, adding approx . 200 ml of drinking water . During cooking, the oven door must remain closed .

#### **DEFROSTING**



For defrosting food more quickly.

#### **ECO FORCED AIR\***



For cooking (stuffed) roasting joints on one shelf only . This function uses gentle, intermittent air circulation to prevent food from drying out excessively . When this ECO function is in use, the light

will remain switched off during cooking but can be switched on again by pressing  . To maximise energy efficiency, we advise against opening the door during cooking . We recommend using the 3rd shelf . It is recommended to brown the meat in a pan before placing it in the oven . The oven does not need to be preheated beforehand .

#### **BREAD AUTO**

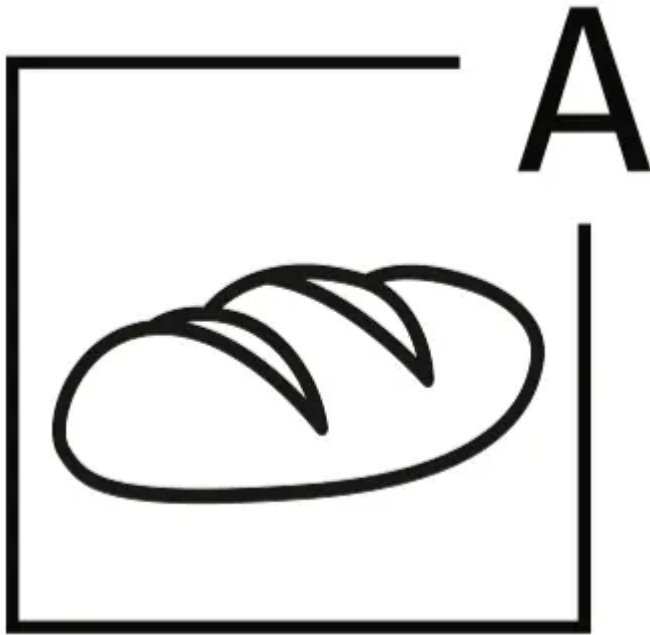

Use this function when baking bread . For best results, we recommend following the recipe carefully . This function automatically selects the ideal temperature and baking time for bread . Cooking will stop automatically and the oven will make a sound when the food is cooked . Activate the function when the oven is cold . If the temperature inside the oven is hotter than that which has been set, the message “Hot” will appear on the display and you will not be able to start cooking . You will need to wait until the oven has cooled down .

#### **DESSERT AUTO**

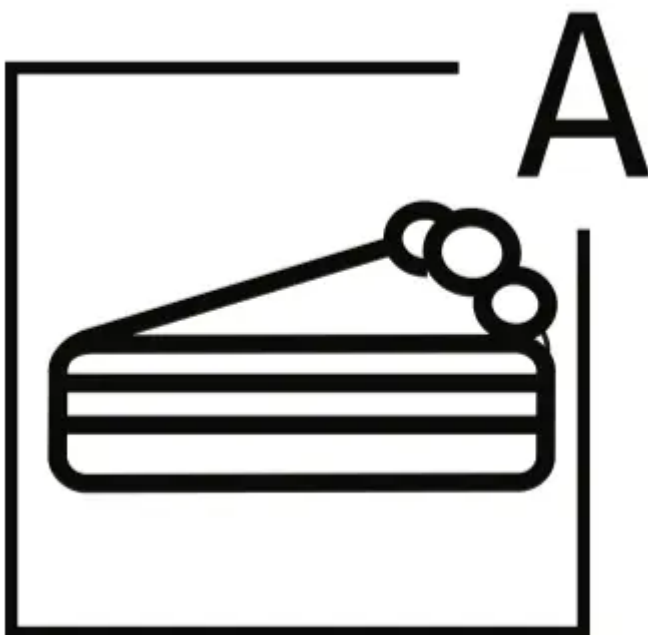



Use this function to bake cakes with or without chemical leaveners . Put the item in the oven when the oven is cold . This function automatically selects the ideal temperature and baking time for







cakes . Cooking will stop automatically and the oven will make a sound when the food is cooked .  
Activate the function when the oven is cold . If the temperature inside the oven is hotter than that  
which has been set, the message “Hot” will appear on the display and you will not be able to start  
cooking . You will need to wait until the oven has cooled down .

## USING THE APPLIANCE FOR THE FIRST TIME

### 1. SETTING THE TIME

You will need to set the time when you switch on the appliance for the first time: Press  until  
the icon  and the current time start flashing on the display.



Use  or  to set the hour and press  to confirm. The two digits for the minutes will  
start flashing. Use  or  to set the minutes and press  to confirm.

**Please note:** When the  icon is flashing, for example following lengthy power outages, you  
will need to reset the time.

### 2. REHEAT THE OVEN

A new oven may release odours that have been left behind during manufacturing: This is  
completely normal.

Before starting to cook food, we therefore recommend heating the oven with it empty in order to  
remove any possible odours.

Remove any protective cardboard or transparent film from the oven and remove any accessories  
from inside it.

Heat the oven to 250 ° C for about one hour, preferably using the “Convection Bake” function. The oven must be empty during this time.

Follow the instructions for setting the function correctly.

**Please note:** It is advisable to air the room after using the appliance for the first time.

## DAILY USE

### 1. SELECT A FUNCTION

To select a function, turn the selection knob to the symbol for the function you require: the display will light up and an audible signal will sound.

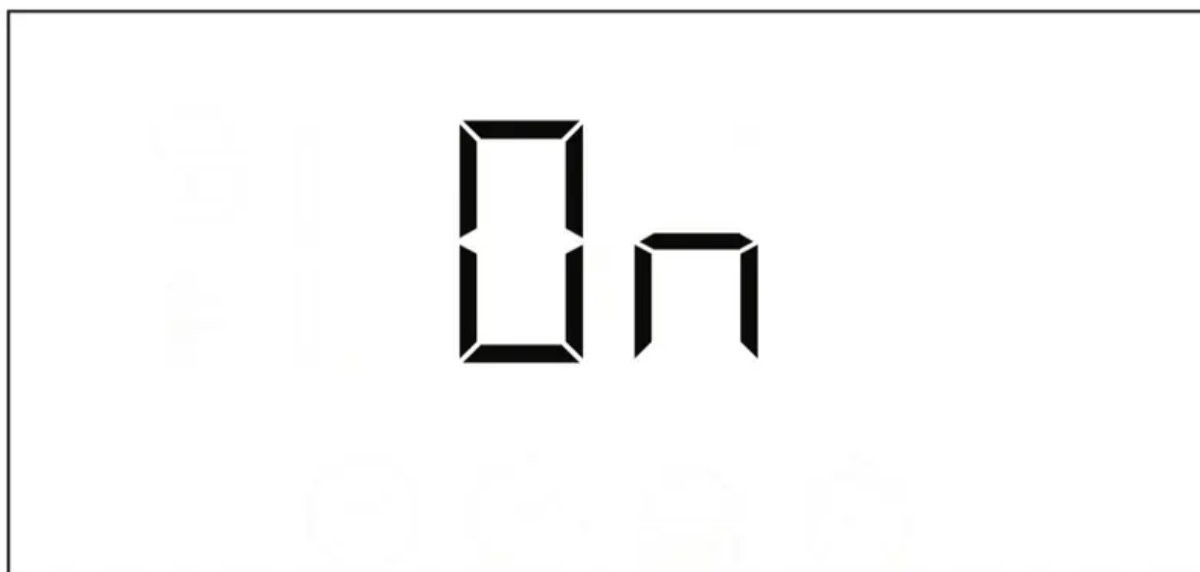

### 2. ACTIVATE A FUNCTION

#### MANUAL

To start the function you have selected, turn the thermostat knob to set the temperature you require.



**Please note:** During cooking you can change the function by turning the selection knob or adjust the temperature by turning the thermostat knob.

The function will only start if the thermostat knob is on 0 °C. You can set the cooking time, cooking end time (only if you set a cooking time) and a timer.

### **AUTOMATIC**

To start the automatic function you have selected (“Bread” or “Pastry”), keep the thermostat knob at the position for automatic functions (  ).

To finish cooking, turn the selection knob to position 0.

**Please note:** You can set the cooking end time and timer.

### **3. PREHEATING**

Once the function starts, an audible signal and a flashing icon  on the display indicate that the preheating phase has been activated.



At the end of this phase, an audible signal and the fixed icon  on the display will indicate that the oven has reached the set temperature: At this point, place the food inside and proceed with cooking.

**Please note:** Placing the food in the oven before preheating has finished may have an adverse effect on the final cooking result.



### **PROGRAMMING COOKING**

You will need to select a function before you can start programming cooking.



### **DURATION**

Keep pressing  until the  icon and “00:00” start flashing on the display.



Use  or  to set the cooking time you require, then press  to confirm.



Activate the function by turning the thermostat knob to the temperature you require: An audible signal will sound and the display will indicate that cooking is complete.

**Notes:** To cancel the cooking time you have set, keep pressing  until the  icon starts flashing on the display, then use  to reset the cooking time to “00:00”.



This cooking time includes a preheating phase.

### PROGRAMMING THE END COOKING TIME/DELAYED START

After a cooking time has been set, starting the function can be delayed by programming its end

time: Press  until the  icon and the current time start flashing on the display.



Use  or  to set the cooking time you want cooking to end and press  to confirm.

Activate the function by turning the thermostat knob to the temperature you require: The function will remain paused until it starts automatically after the period of time that has been calculated in order for cooking to finish at the time you have set.



**Notes:** To cancel the setting, switch the oven off by turning the selection knob to position "0".

#### END OF COOKING

An audible signal will sound and the display will indicate that the function has finished.

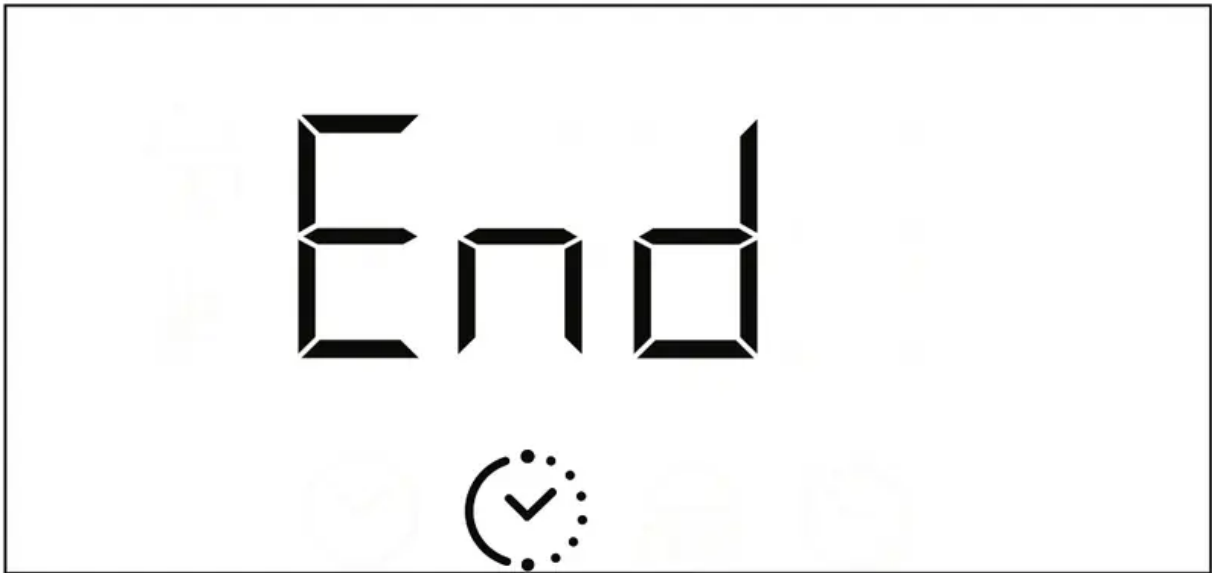



Turn the selection knob to select a different function or to position " 0 " to switch the oven off.



**Please note:** If the timer is active, the display will show "END" alternately with the remaining time.

### SETTING THE TIMER

This option does not interrupt or program cooking but allows you to use the display as a timer, either during while a function is active or when the oven is off.

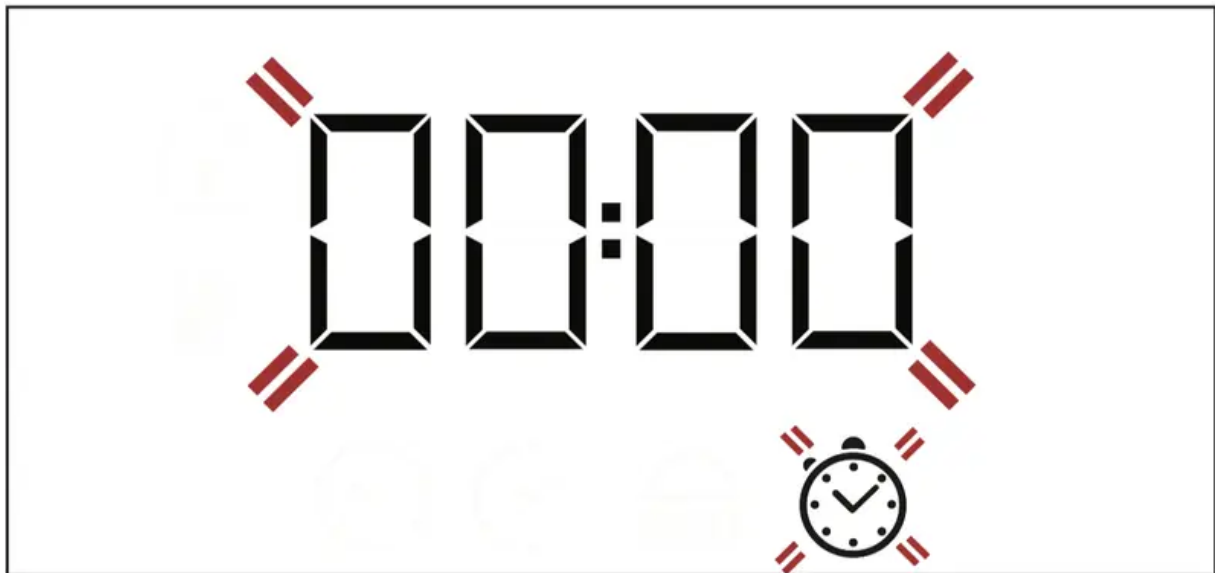
Keep pressing  until the  icon and "00:00" start flashing on the display.



Use  or  to set the time you require and press  to confirm.

An audible signal will sound once the timer has finished counting down the selected time.

**Notes:** To cancel the timer, keep pressing  until the icon  starts flashing, then use  to reset the time to “00:00”.

## USEFUL TIPS

### HOW TO READ THE COOKING TABLE

The table indicates the best function to use for any given food, to be cooked on one or more shelves at the same time . Cooking times start from the moment food is placed in the oven, excluding preheating (where required) . Cooking temperatures and times are purely for guidance and will depend on the amount of food and type of accessory used . Use the lowest recommended settings to begin with and, if the food is not cooked enough, then switch to higher settings . Use the accessories supplied and preferably dark-coloured metal cake tins and baking trays . You can also use Pyrex pans and accessories or ones made from china, but bear in mind that cooking times will be slightly longer . For best results, follow the recommendations in the cooking table carefully when selecting which of the supplied accessories to place on which of the shelves .

### COOKING DIFFERENT FOODS AT THE SAME TIME

Using the “Convection Bake” function, you can cook different foods simultaneously (for example: fish and vegetables), using different shelves . Switch shelves two thirds of the way through cooking, if necessary . Remove the food which requires a shorter cooking time and leave the food which requires a longer cooking time in the oven .

### DESSERTS

- Cook delicate desserts with the conventional function on one shelf only . Use dark-coloured metal baking pans and always place them on the wire shelf supplied . To cook on more than one shelf, select the “Convection bake” function and position the baking pans on different shelves to facilitate the circulation of hot air .
- Use dark-coloured metal baking pans and always place them on the wire shelf supplied .
- To check whether a leavened cake is cooked, insert a wooden toothpick into the centre of the cake . If the toothpick comes out clean, the cake is ready .

If using non-stick cake tins, do not butter the edges as the cake may not rise evenly around the edges .

- If the item “swells” during baking, use a lower temperature next time and consider reducing the amount of liquid you add or stirring the mixture more gently .
- For desserts with moist fillings or toppings (such as cheesecake or fruit tarts), use the “Convection bake” function . If the base of the cake is soggy, lower the shelf and sprinkle the bottom of the cake with breadcrumbs or biscuit crumbs before adding the filling .

## MEAT

- Use any kind of oven tray or pyrex dish suited to the size of the piece of meat being cooked .

For roast joints, it is best to add some stock to the bottom of the dish, basting the meat during cooking for added flavour . Please note that steam will be generated during this operation . When the roast is ready, let it rest in the oven for another 1015 minutes, or wrap it in aluminium foil .

- When grilling pieces of meat, choose cuts of the same thickness to obtain even cooking . Very thick pieces of meat require longer cooking times . To prevent the meat from burning on the outside, lower the position of the wire shelf, keeping the food farther away from the grill . Turn the meat two thirds of the way through cooking . Take care when opening the door as steam will escape .

To collect the cooking juices, we recommend placing a dripping pan filled with 200 ml of drinking water directly underneath the wire shelf on which the food is placed . Refill as necessary .

## PIZZA

Lightly grease the trays to ensure the pizza has a crispy base . Scatter the mozzarella over the pizza two thirds of the way through cooking .





















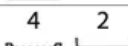



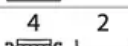









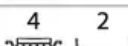

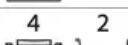

## BREAD AUTO FUNCTION

Use this function when baking bread: For best results, follow the instructions given in the recipe carefully . Recipe for 1000 g of dough: 600 g of flour, 360 g of water, 11 g of salt, 25 g of fresh yeast (or two packets of yeast powder) .

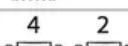
### Method:

- Mix the flour and salt together in a large bowl .
- Dilute the yeast in the water (this must be slightly warm – around 35° C) .
- Make a well in the flour and add the water/ yeast mixture, then work into a smooth, slightly sticky dough . Knead the dough with your hands, stretching it out and folding it over for around 10 minutes . Shape the dough into a ball and leave it to rise in a bowl covered with a transparent lid to prevent the surface of the dough from drying out .
- Wait until the dough has doubled in volume: Allow about 90 minutes at room temperature to achieve optimum raising .
- Divide the dough into one or two loaves, sprinkle with flour and make little cuts on the surface . Then place the bread on a baking tray lined with baking parchment .
- Place the dough in the (cold) oven, pour 100 ml of cold drinking water onto the bottom of the oven and activate the “Bread Auto” function . After cooking, leave the dough to stand on a wire shelf until completely cooled .

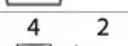
## COOKING TABLE

RECIPE	FUNCTION	PREHEAT	TEMPERATURE (°C)	DURATION (MIN)	LEVEL AND ACCESSORIES
<b>Leavened cakes</b>		Yes	160-180	30-90	2/3 
		Yes	160-180	30 - 90 ***	4 1 
<b>Filled cake</b> (cheesecake, strudel, fruit pie)		Yes	160-200	35-90	2 
		Yes	160-200	35 - 90 ***	4 2 
<b>Biscuits/tartlets</b>		Yes	170 - 180	15 - 45	3 
		Yes	160-180	20-45 ***	4 2 
<b>Choux buns</b>		Yes	180 - 220	30-40	3 
		Yes	180-190	35-45 ***	4 2 
<b>Meringues</b>		Yes	90	150 - 200	3 
		Yes	90	140 - 200	4 2 
<b>Bread</b>		-	-	60	2 
<b>Bread/pizza/focaccia</b>		Yes	190-250	15-50	2 
		Yes	190-250	25-50 ***	4 2 
<b>Frozen pizza</b>		Yes	250	10 - 15	3 
		Yes	250	10 - 20 ***	4 2 
<b>Salty cakes</b> (vegetable pie, quiche)		Yes	175 - 200	45 - 60	3 
		Yes	175 - 200	45 - 60 ***	4 2 
<b>Vols-au-vents/puff pastry crackers</b>		Yes	190-200	20-30	3 
		Yes	180-190	15 - 40 ***	4 2 
<b>Lasagne/baked pasta/cannelloni/flans</b>		Yes	190-200	45-65	2 

RECIPE	FUNCTION	PREHEAT	TEMPERATURE (°C)	DURATION (MIN)	LEVEL AND ACCESSORIES
Lamb/veal/beef/pork 1 kg		Yes	190-200	80-110	3
Chicken/rabbit/duck 1 kg		Yes	200-230	50-100	2
Turkey/goose 3 kg		-	190-200	100 - 160	2
Baked fish/en papillote (fillet, whole)		Yes	170 - 190	30 - 50	2
Stuffed vegetables (tomatoes, courgettes, eggplants)		Yes	180-200	50 - 70	2 
Toasted bread		5'	250	2 - 6	5 
Fish fillets/slices		-	230 - 250	15 - 30 *	4 3 
Sausages/kebabs/spare ribs/hamburgers		-	250	15 - 30 *	5 4 
Roast chicken 1-1.3 kg		Yes	200 - 220	55-70 **	2 1 
Roast beef rare 1 kg		Yes	200 - 210	35-50 **	3 
Leg of lamb/knuckle		Yes	200 - 210	60-90 **	3 
Roast potatoes		Yes	200 - 210	35-55 **	3 
Vegetable gratin		-	200 - 210	25 - 55	3 
Lasagne and meat		Yes	200	50 - 100 ****	4 1 
Meat and potatoes		Yes	190-200	45 - 100 ****	4 1 
Fish and vegetables		Yes	180	30 - 50 ****	4 1 
Roast meat/stuffed roasting joints		-	170 - 180	100 - 150	2 

FUNCTIONS	Conventional	Grill	Turbo Grill	Convection Bake	Bread Auto	Eco Forced Air
ACCESSORIES	Wire shelf	Baking dish or baking tray on the wire shelf	Baking tray/oven tray on wire shelf	Baking tray with 200 ml of water	Baking tray	

The time indicated does not include the preheating phase: We recommend placing the food in the oven and setting the cooking time only after the required temperature has been reached.

\* Turn food halfway through cooking

\*\* Turn food two thirds of the way through cooking (if necessary).

\*\*\* Switch levels halfway through cooking.

\*\*\*\* Estimated length of time: Dishes can be removed from the oven at different times depending on personal preference. Switch shelves two thirds of the way through cooking, if necessary.

## CLEANING

**Do not use steam cleaning equipment.**

**Use protective gloves during all operations.**

**Carry out the required operations with the oven cold.**

**Disconnect the appliance from the power supply.**

**Do not use wire wool, abrasive scourers or abrasive/corrosive cleaning agents, as these could damage the surfaces of the appliance.**

## **EXTERIOR SURFACES**

- Clean the surfaces with a damp microfibre cloth. If they are very dirty, add a few drops of pH-neutral detergent. Finish off with a dry cloth.
- Do not use corrosive or abrasive detergents. If any of these products inadvertently comes into contact with the surfaces of the appliance, clean immediately with a damp microfibre cloth.

## **INTERIOR SURFACES**

- This oven is equipped with special catalytic panels that facilitate cleaning of the cooking compartment thanks to their special self-cleaning coating, which is highly porous and able to absorb grease and grime .  
**Please note:** Using corrosive or abrasive cleaning agents, stiff brushes, pan scourers or oven sprays could damage the catalytic surface and compromise its self-cleaning properties.  
Please contact our After-sales Service if you require replacement panels .
- After every use, leave the oven to cool and then clean it, preferably while it is still warm, to remove any deposits or stains caused by food residues To dry any condensation that has formed as a result of cooking foods with a high water content, let the oven to cool completely and then wipe it with a cloth or sponge .
- Clean the glass in the door with a suitable liquid detergent .
- The door can be easily removed and refitted to facilitate cleaning of the glass .
- The top heating element of the grill can be lowered to clean the upper panel of the oven .

## **ACCESSORIES**

Soak the accessories in a washing-up liquid solution after use, handling them with oven gloves if they are still hot. Food residues can be removed using a washing-up brush or a sponge.

## **CLICK & CLEAN - CLEANING THE GLASS**

1. After removing the door and resting it on a soft surface with the handle downwards, simultaneously press the two retaining clips and remove the upper edge of the door by pulling it towards you .

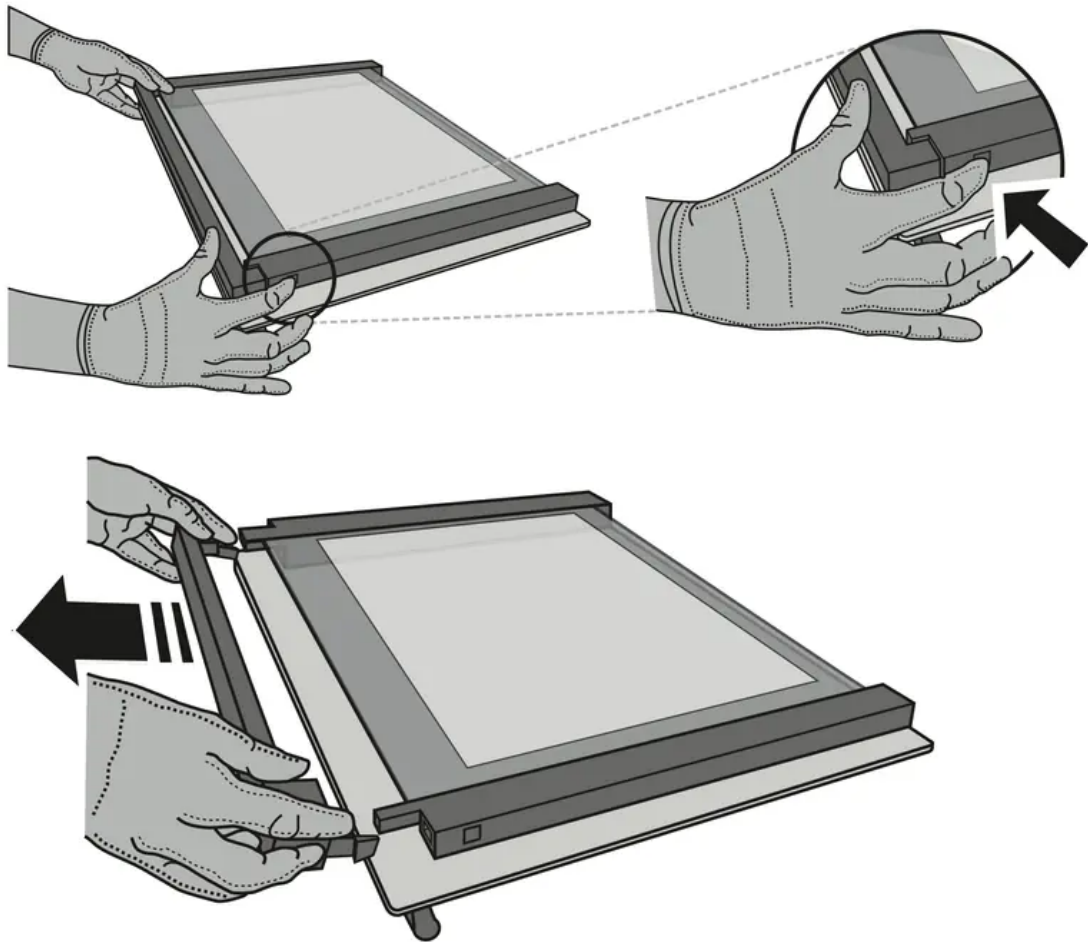

2. Lift and firmly hold the inner glass with both hands, remove it and place it on a soft surface before cleaning it .

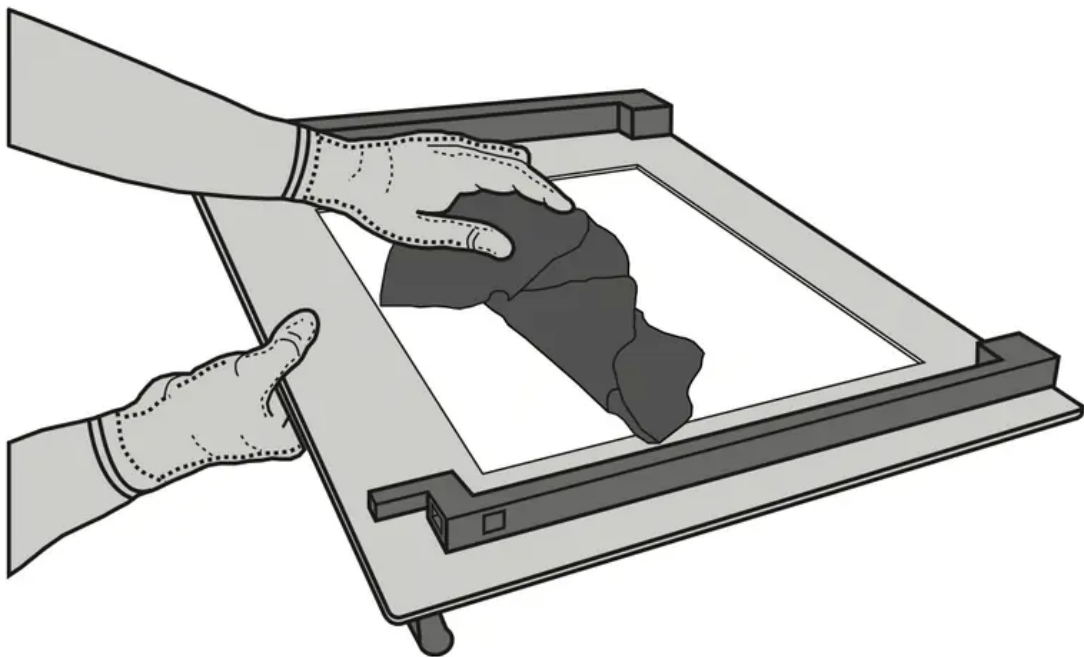

**3.** To correctly reposition the inner glass, make sure that the “R” is visible in the right-hand corner and the clear surface (not printed) is facing up .

First insert the long side of the glass indicated by “R” into the support seats, then lower it into position .

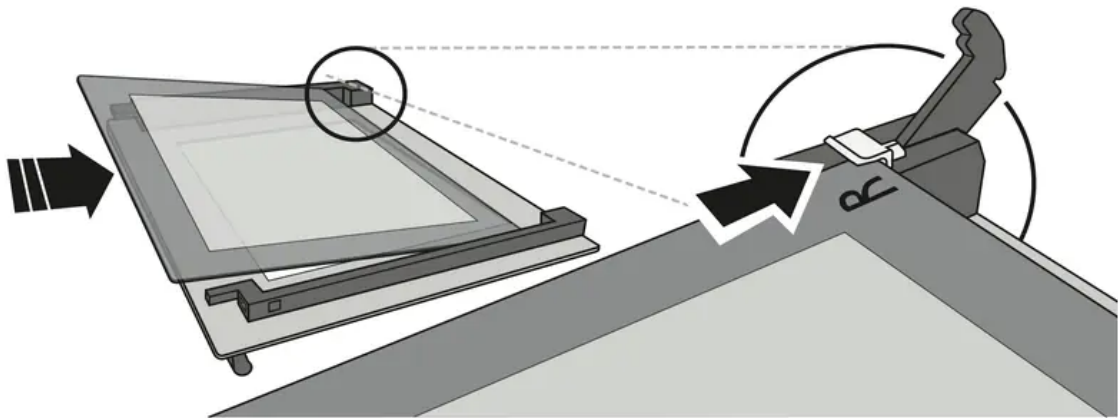

4. Refit the upper edge: A click will indicate correct positioning . Make sure the seal is secure before refitting the door .

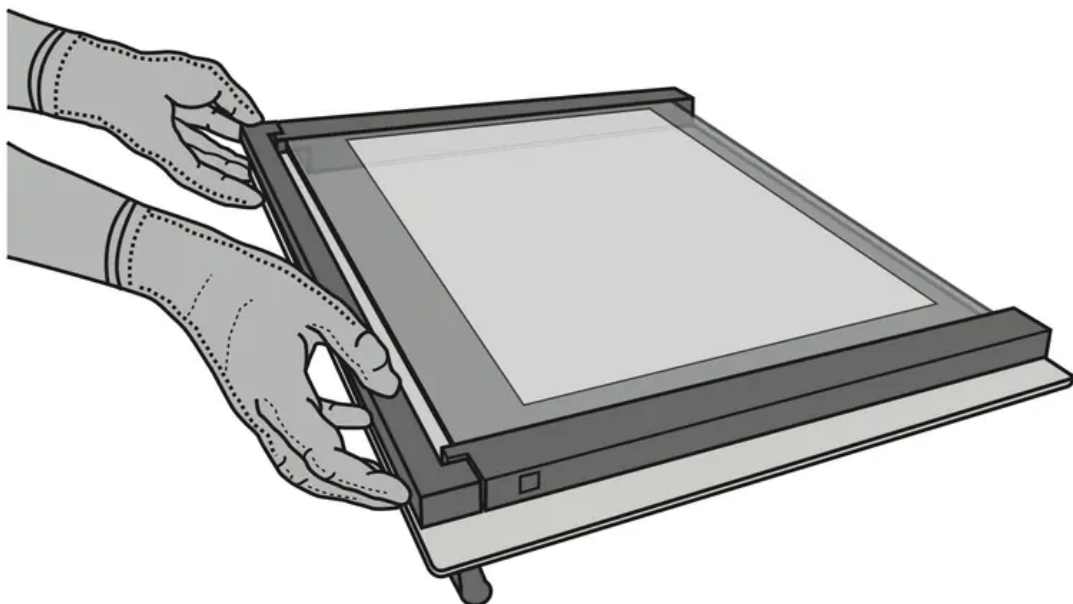
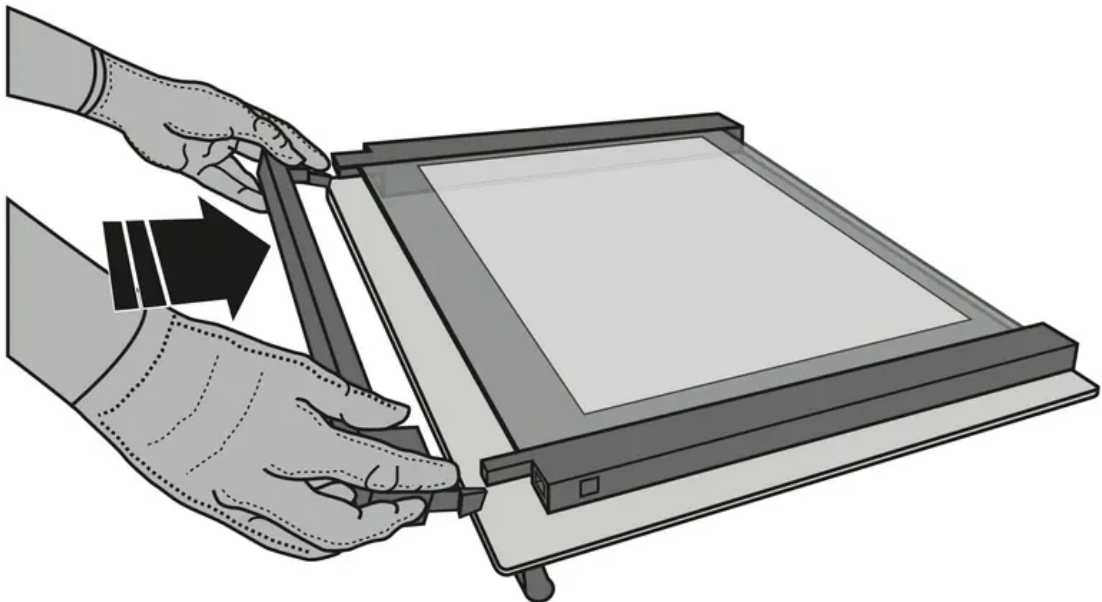

## MAINTENANCE

Use protective gloves during all operations.

Carry out the required operations with the oven cold.

Disconnect the oven from the power supply.

### REMOVING AND REFITTING THE DOOR

1. Open the door fully .

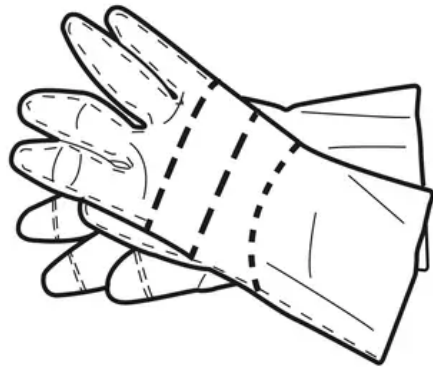
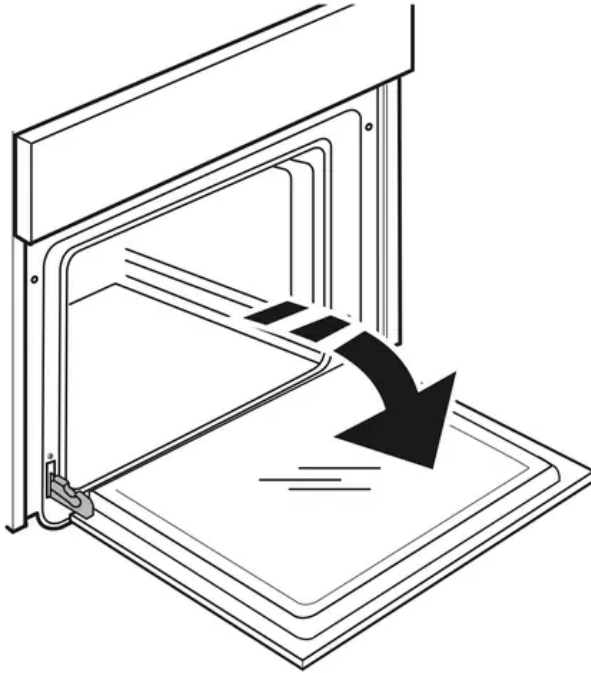

2. Lower the catches as far as possible .

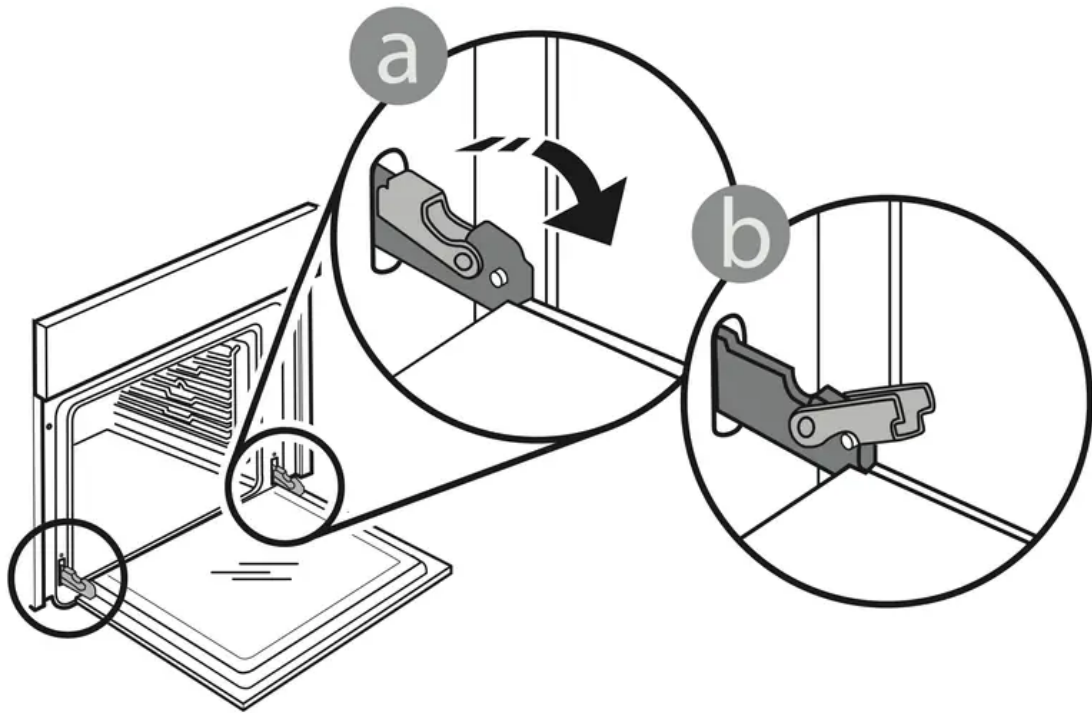

3. Close the door as much as you can .

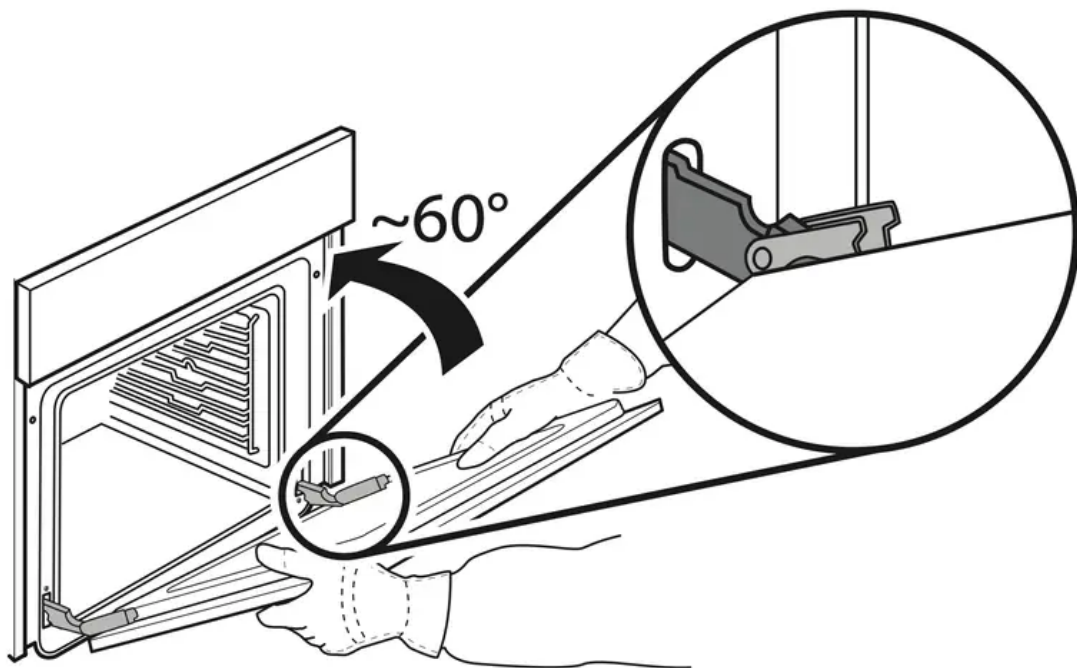

4. Take a firm hold of the door with both hands – do not hold it by the handle . Simply remove the door by continuing to close it while pulling it upwards at the same time until it is released from its seating .

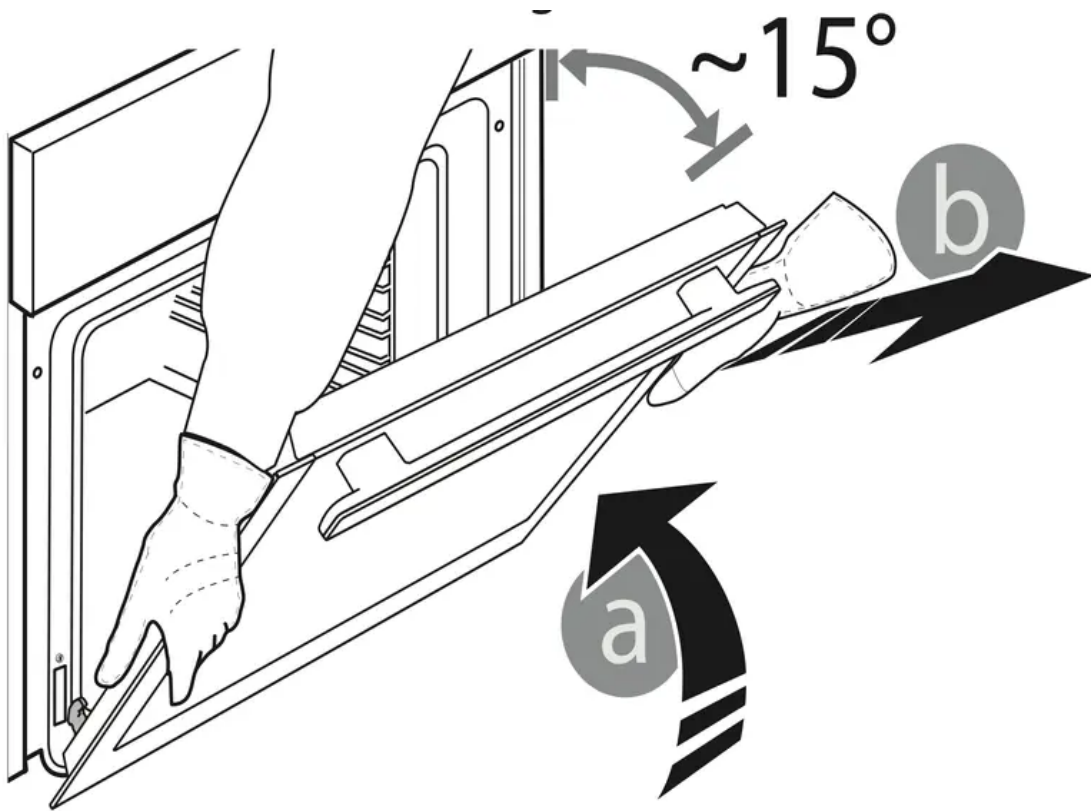

5. Put the door to one side, resting it on a soft surface .

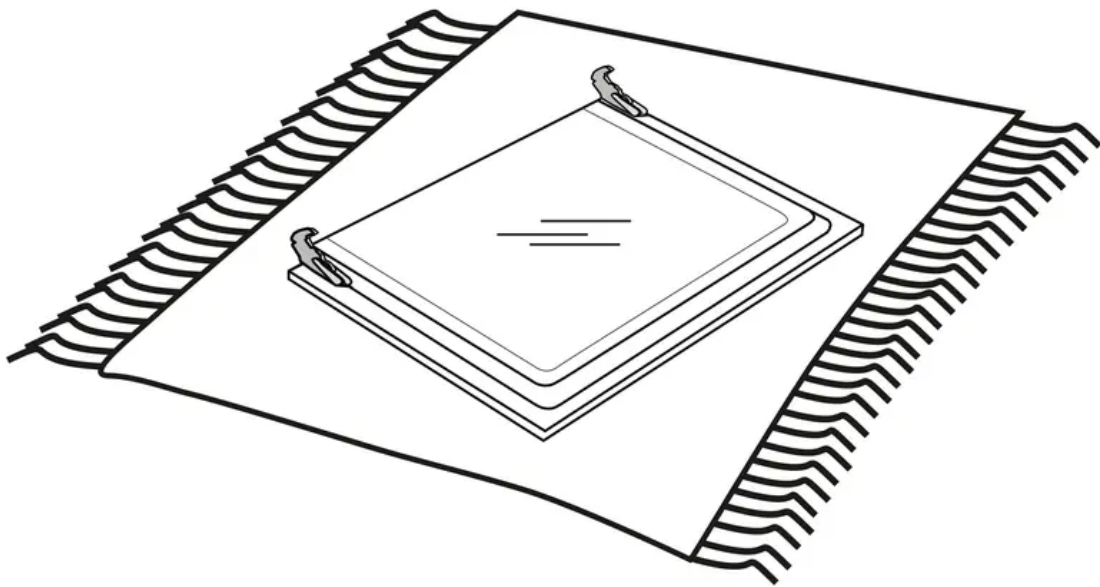

## REFITTING THE DOOR

1. Move the door towards the oven, aligning the hooks of the hinges with their seating .

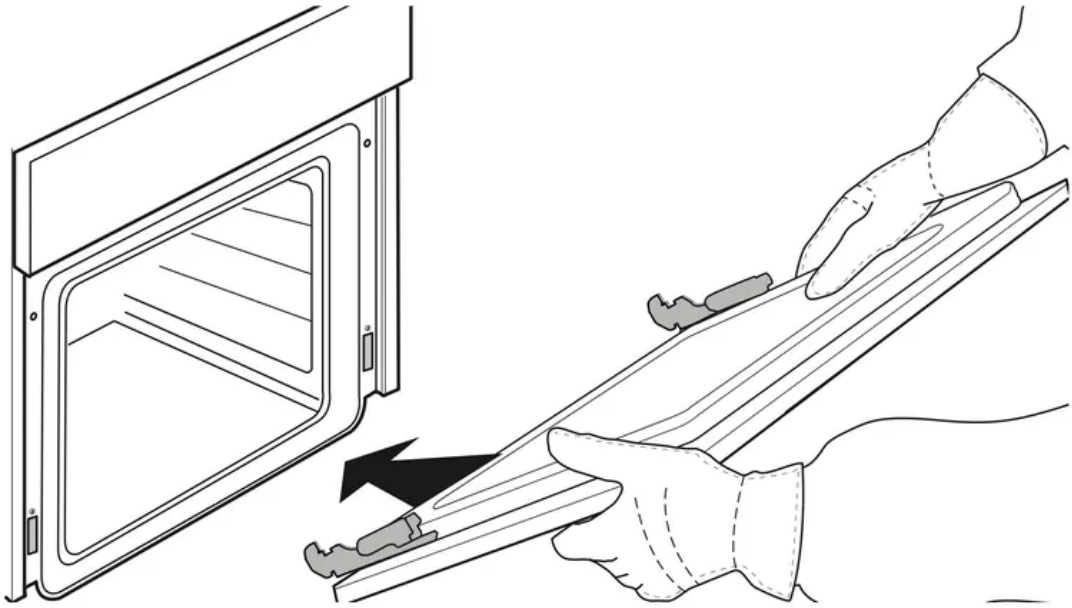

2. Secure the upper part into its seating .

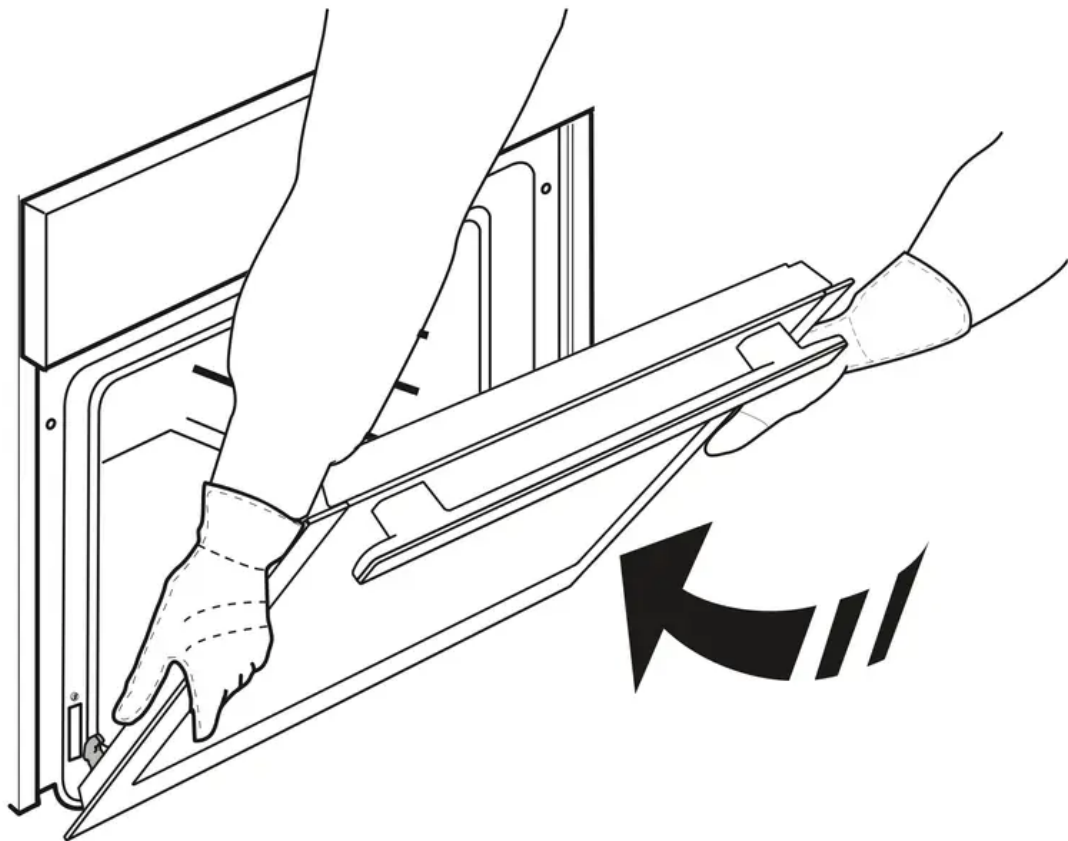

3. Lower the door and then open it fully .

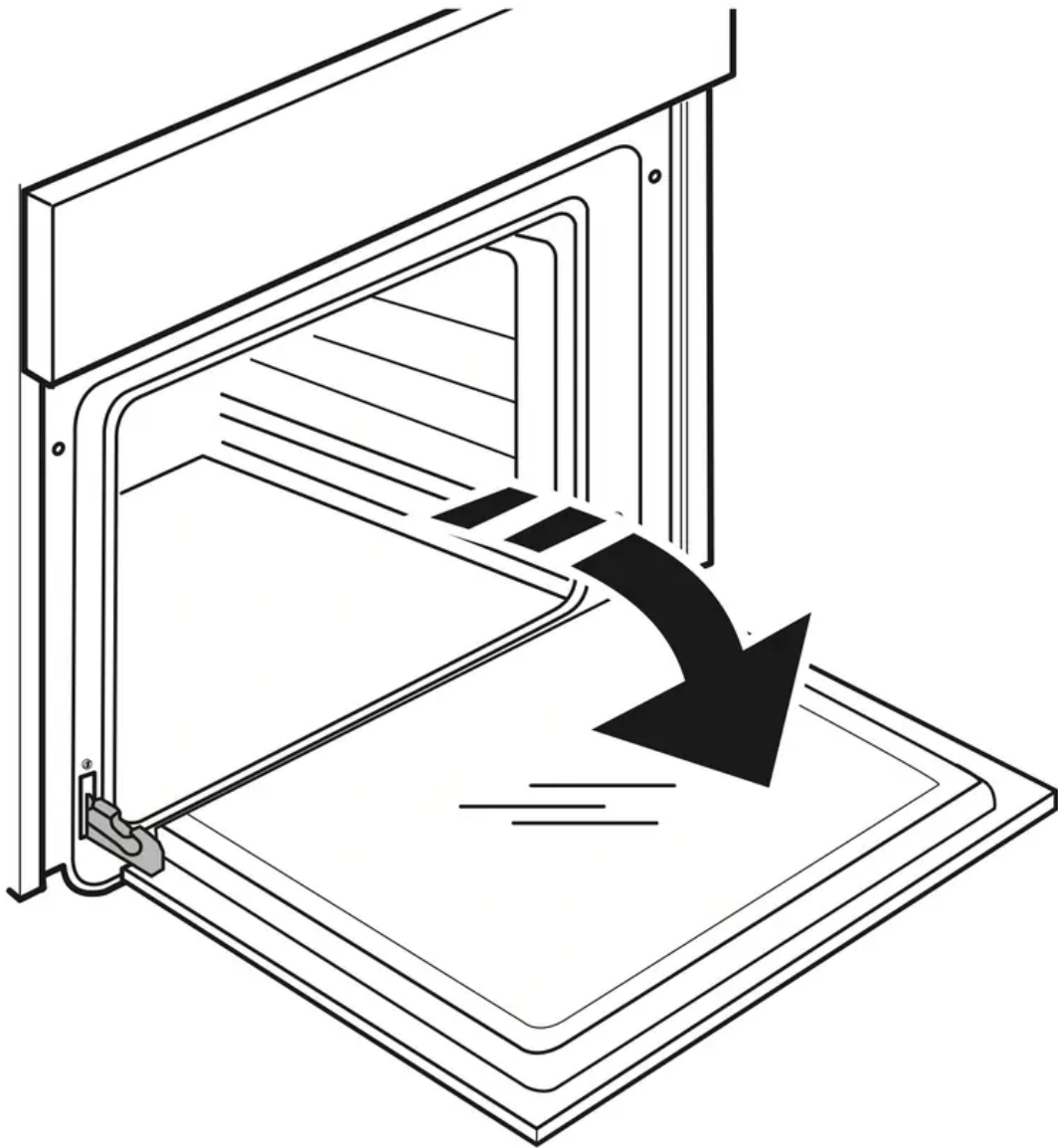

4. Lower the catches into their original position: Make sure that you lower them down completely .

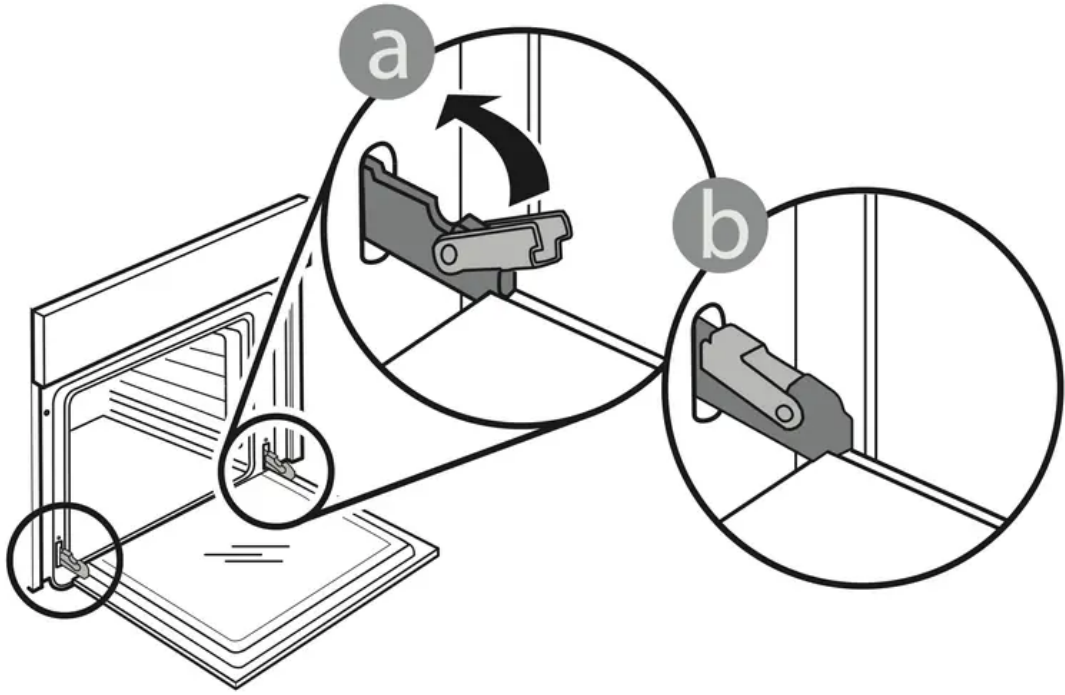

5. Try closing the door and check to make sure that it lines up with the control panel . If it does not, repeat the steps above: The door could become damaged if it does not work properly .

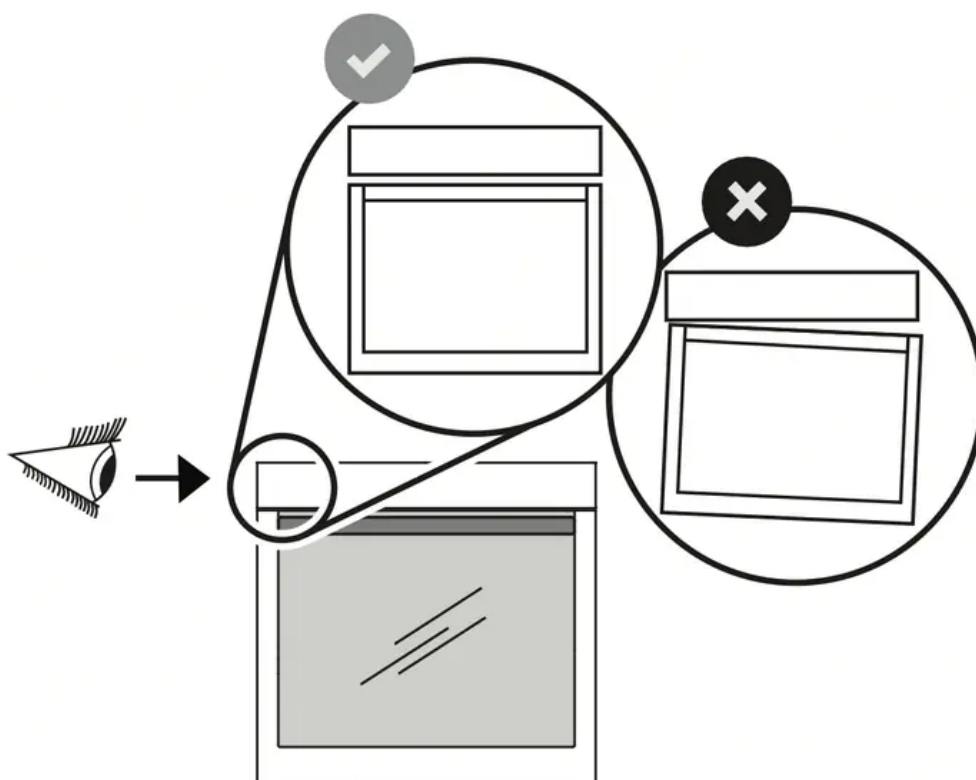
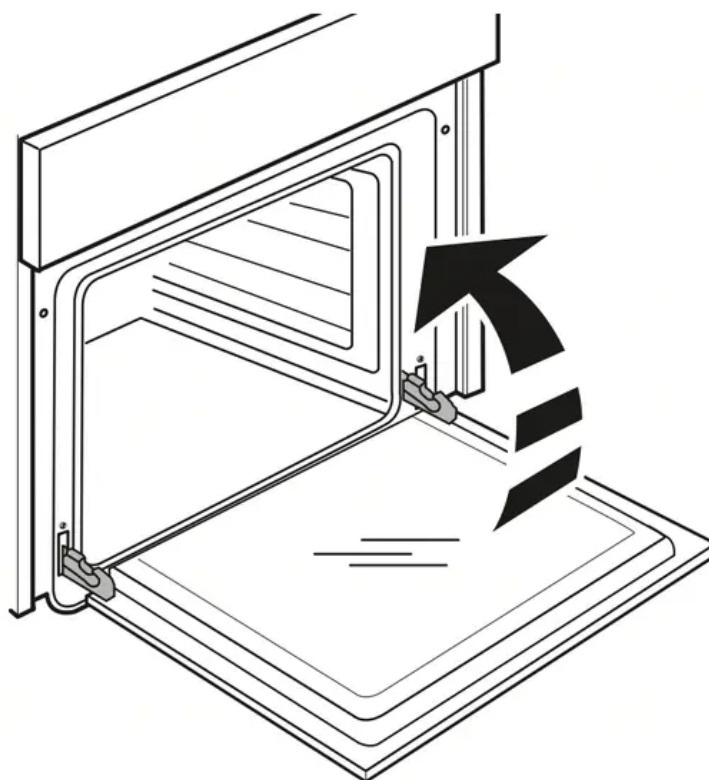

## REPLACING THE LIGHT

1. Disconnect the oven from the power supply .
2. Unscrew the cover from the light, replace the bulb and screw the cover back on the light .

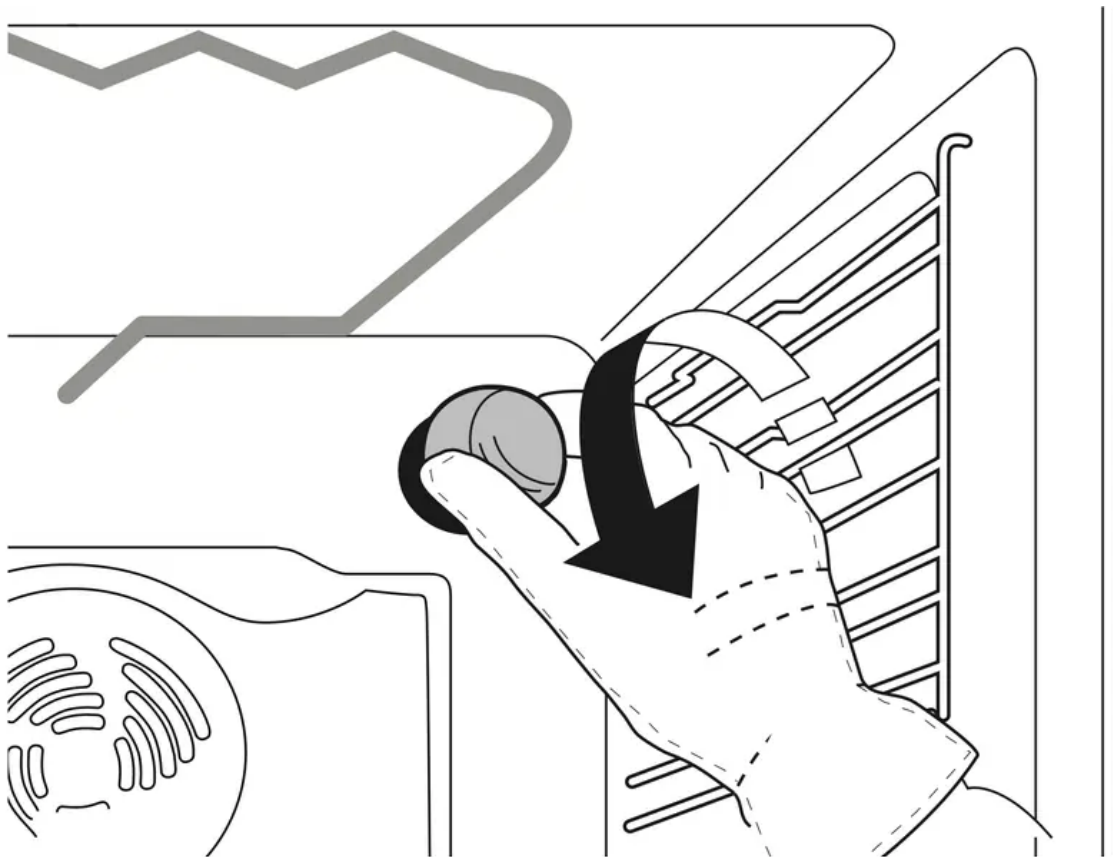

**3.** Reconnect the oven to the power supply .

**Please note:** Use 25 W/230 V type G9, T300 °C halogen lamps.

The bulb used in the product is specifically designed for domestic appliances and is not suitable for general room lighting within the home (EC Regulation 244/2009).

Light bulbs are available from our After-sales Service.

- Do not handle bulbs with your bare hands as your fingerprints could damage them. Do not use the oven until the light cover has been refitted.

## TROUBLESHOOTING

Problem	Possible cause	Solution
The oven does not work	Disconnection from the mains electricity.  Fault.	Make sure that the oven is connected to the main electricity supply.  Turn off the oven and restart it to see if the fault persists.
The display is showing the message "Hot" and the selected function will not start .	Temperature too high.	Allow the oven to cool down before activating the function. Select a different function.
Cooking will not start .	Temperature not set/ thermostat knob in the wrong position.	Turn the thermostat knob to the temperature or the position you require to activate the function you have selected.
The time is flashing .	Power cut.	You need to reset the time: Follow the instructions given in the "Using the appliance for the first time" section.
The display shows the letter "F" followed by a number .	Software fault.	Contact you nearest Client After-sales Service Centre and state the number following the letter "F".
The light is not working .	Oven OFF.  Bulb gone.	Turn the selection knob to select a function and switch on the oven.  If the fault persists, follow the instructions for replacing the bulb given in the "Maintenance" section.

### Warning

This content is compiled from multiple sources and is provided for reference purposes only. It may not be complete or fully applicable to all situations. If you are unable to resolve your issue, please contact the product manufacturer or an authorized service provider for official support.

