

Installing the stands or wall-mount bracket

- If you want to place your TV on a table or in an entertainment center, go to Installing the stands.
- If you want to mount your TV on a wall, go to Installing a wall-mount bracket.

Notes

- If you plan to wall-mount your TV, do not install the stands.
- Store the stands and stand screws in case you decide to use the stands in the future.

Installing the stands

1. Carefully place your TV face-down on a cushioned, clean surface to protect the screen.

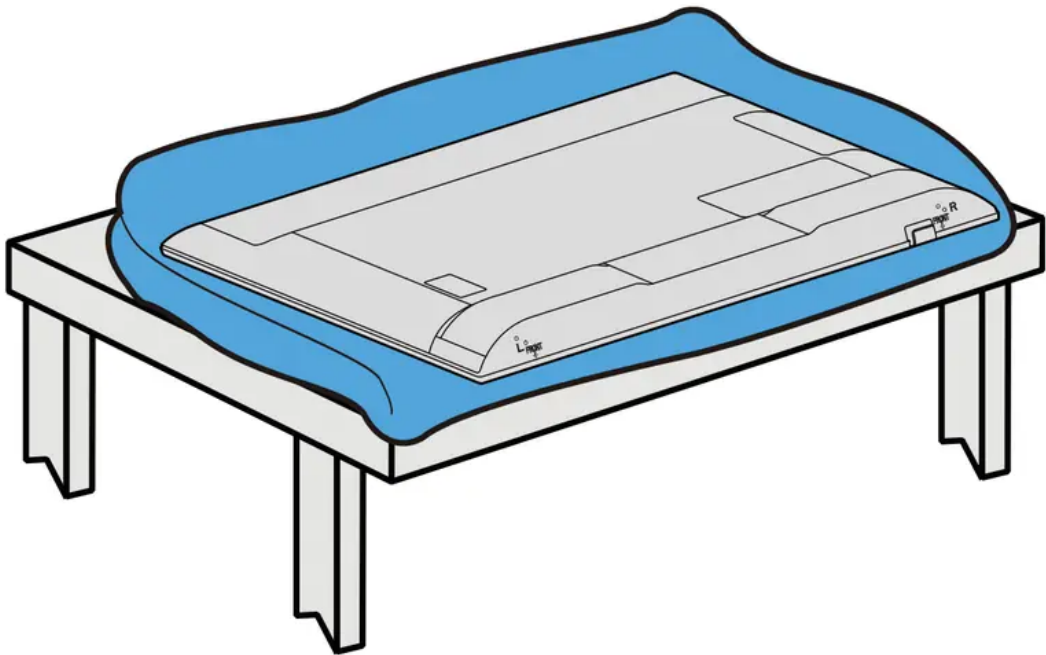

2. Align the TV stands with the screw holes on the bottom of the TV. Make sure that the arrows on the stands are pointing towards the front of the TV. Secure the stands to the

TV with the four provided screws.

Screw type	Screw length	# of screws
M4	20 mm	4

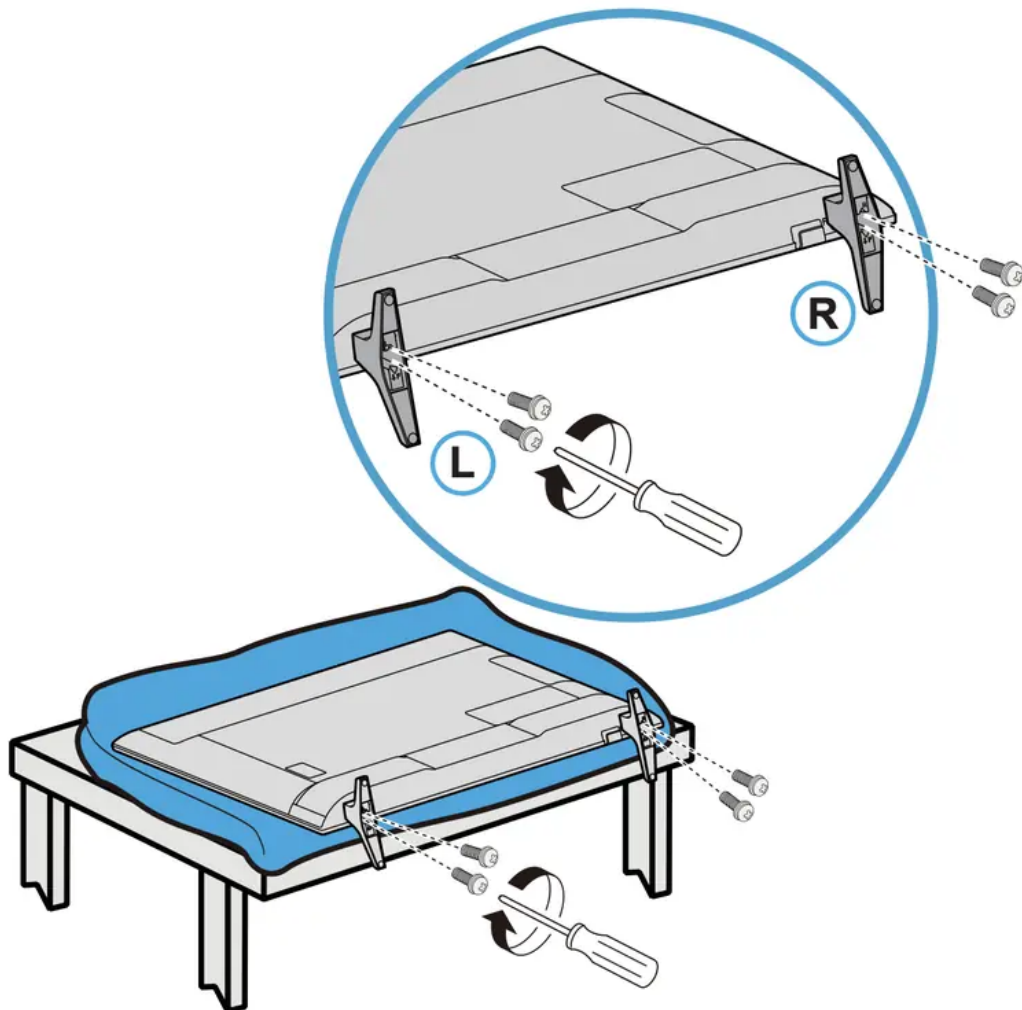

Installing a wall-mount bracket

Warnings

- Your TV has four VESA mounting holes on the back. If you attach a wall-mount bracket to the back of your TV, the bracket must be securely attached, using all four holes. If you do not use all four mounting holes, your TV may fall and cause property damage or personal injury. See the documentation that came with your wall mount for complete mounting instructions.

- Your TV is intended to be supported by a UL Listed wall mount bracket with suitable weight/load. (See Miscellaneous on page 44.)

1. Carefully place your TV face-down on a cushioned, clean surface to protect the screen.

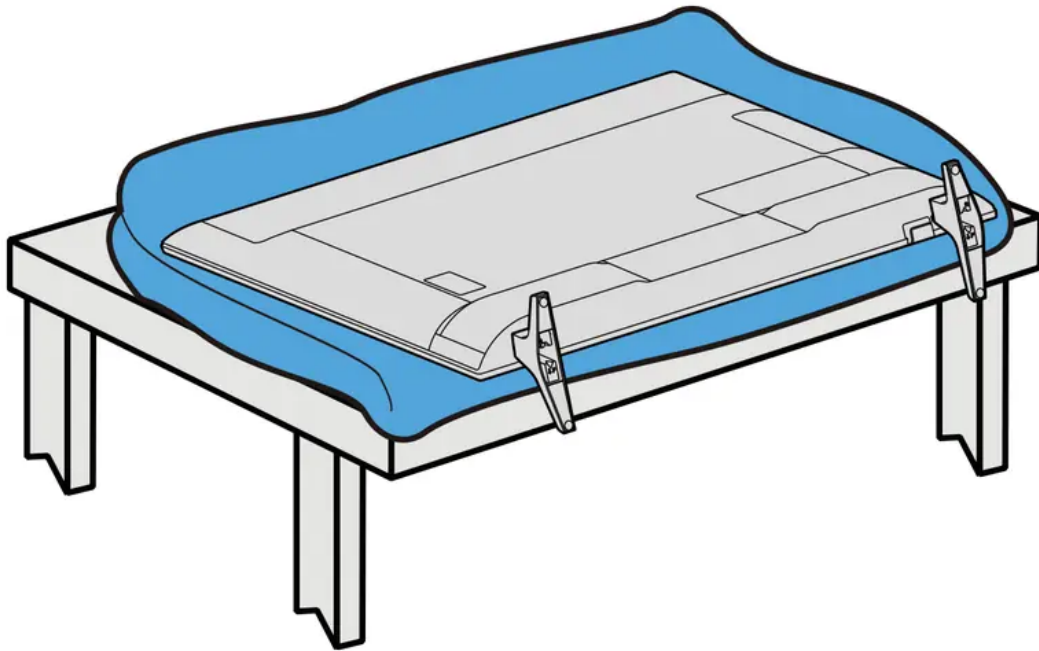

2. If the TV stands are installed, remove the four screws that secure the stands to your TV.

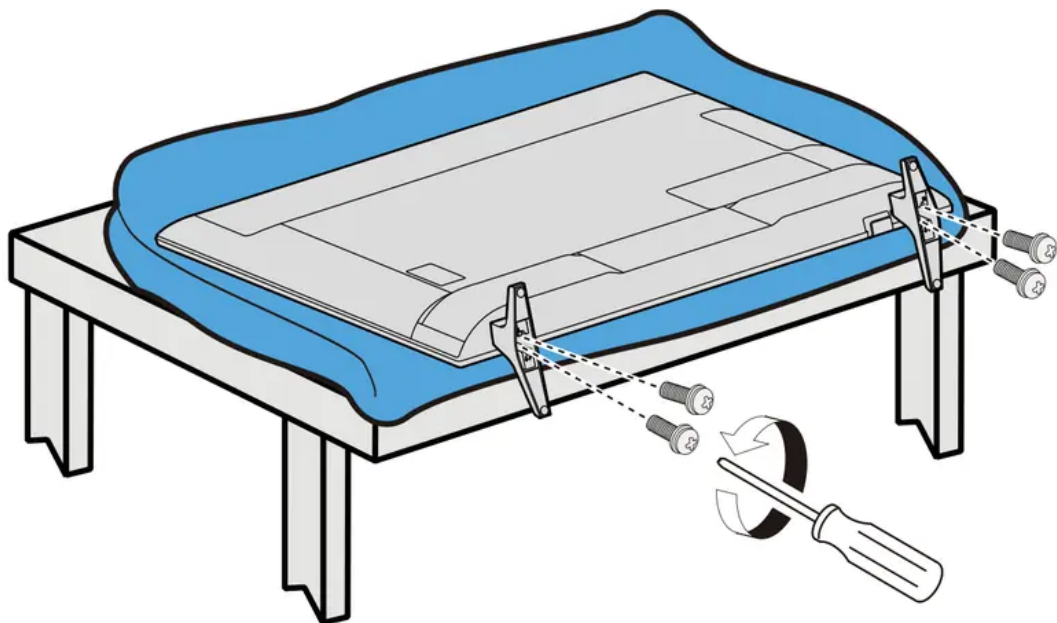

3. Attach the wall-mount bracket to your TV using the mounting holes on the back of your TV. See the instructions that came with the wall-mount bracket for information about how to correctly hang your TV.

Notes:

The length of the wall-mount screws vary depending on the wall-mount bracket you purchased. See the instructions that came with the wall-mount bracket for screw lengths.

The mounting holes on the back of your TV take type M6 screws (14 mm).

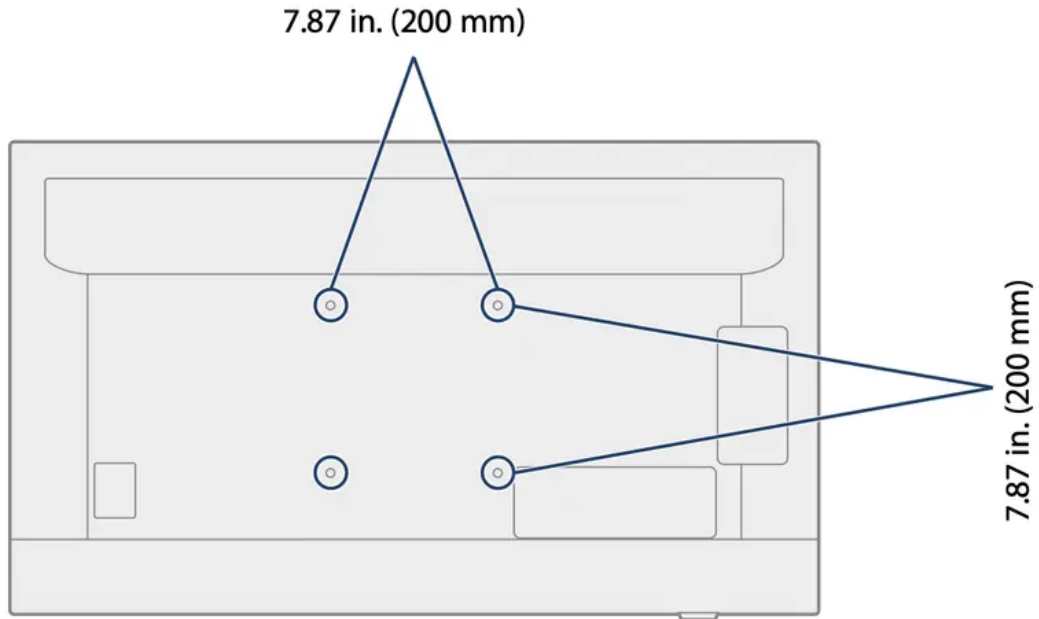

TV components

Your TV has built-in controls for adjusting basic settings and several sets of jacks for connecting devices to your TV.

This section contains information about:

- Package contents
- Front features
- Side jacks
- Back jacks
- Remote control

Package contents

- 43" or 50" LED Sharp Roku TV
- Remote control and batteries (2 AAA)
- TV stands (2)
- Screws (4)
- Power cord
- Quick Setup Guide
- Important Information
- Roku TV End User License Agreement (EULA)

Front features

Besides the viewing screen, the front has a remote control sensor, to receive the signals from the remote control (do not block), and a status indicator.

The status indicator lights red when your TV is off, turns off when your TV is on, or blinks when receiving commands from the remote control.

Side jacks

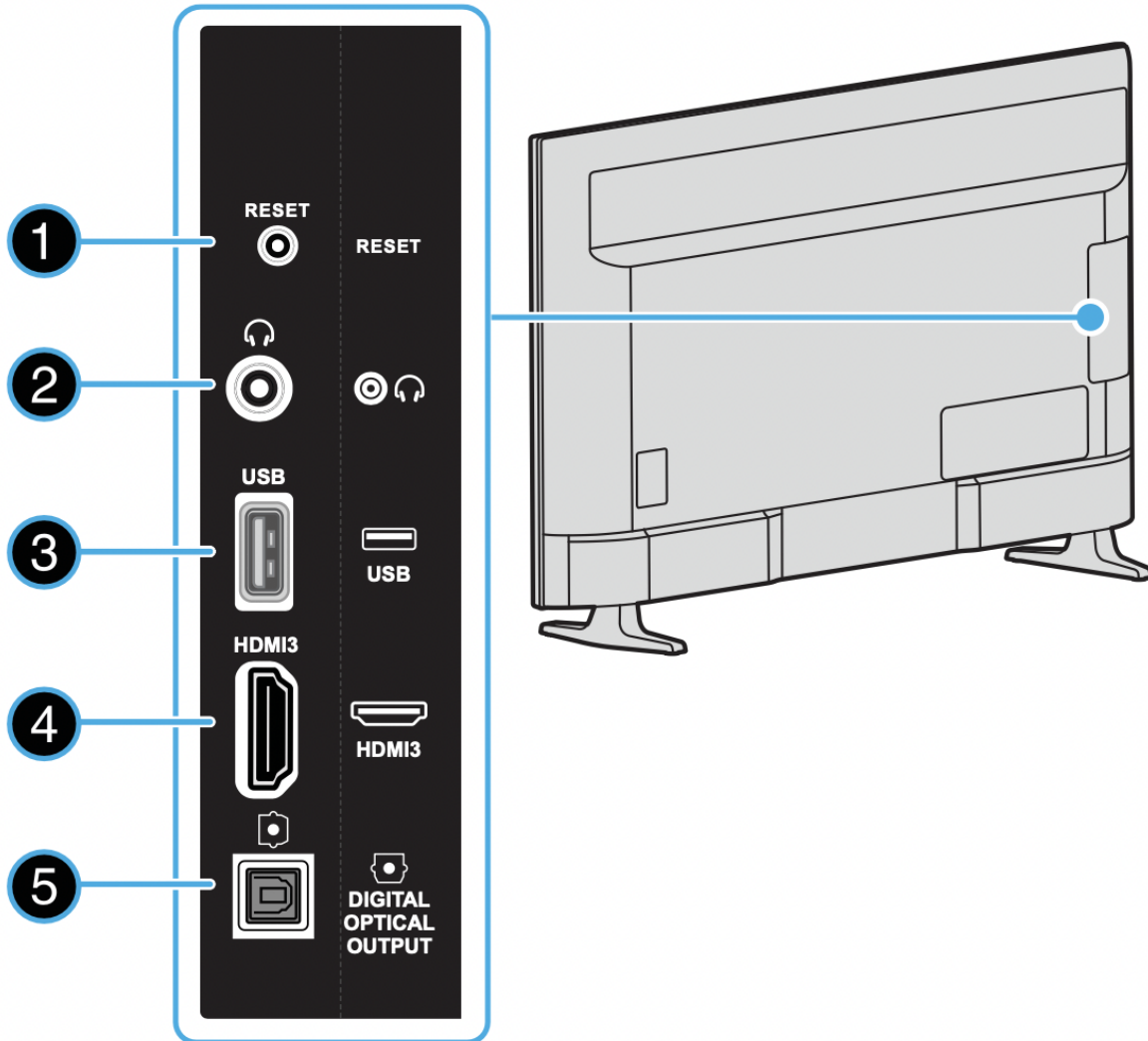

#	Item	Description
1	RESET	Press and hold reset for 15 seconds for factory reset.
2	 (headphones)	Connect headphones to this jack. See Connecting headphones on page 28.
3	USB	Connect a USB flash drive to this jack to view compatible photos and video, listen to music files, or pause live TV. For more information, see Connecting a USB flash drive on page 27 and Pause live TV on page 7.
4	HDMI3	Connect HDMI® devices to this jack. For more information, see HDMI® (best) on pages 18, 22, or 24 or Connecting a computer on page 26.
5	DIGITAL OUTPUT (OPTICAL)	Connect a digital sound bar, speaker system, or home theater system to this jack to listen to TV audio through external speakers. For more information, see Digital audio using the DIGITAL OUTPUT (OPTICAL) jack on page 29.

Back jacks

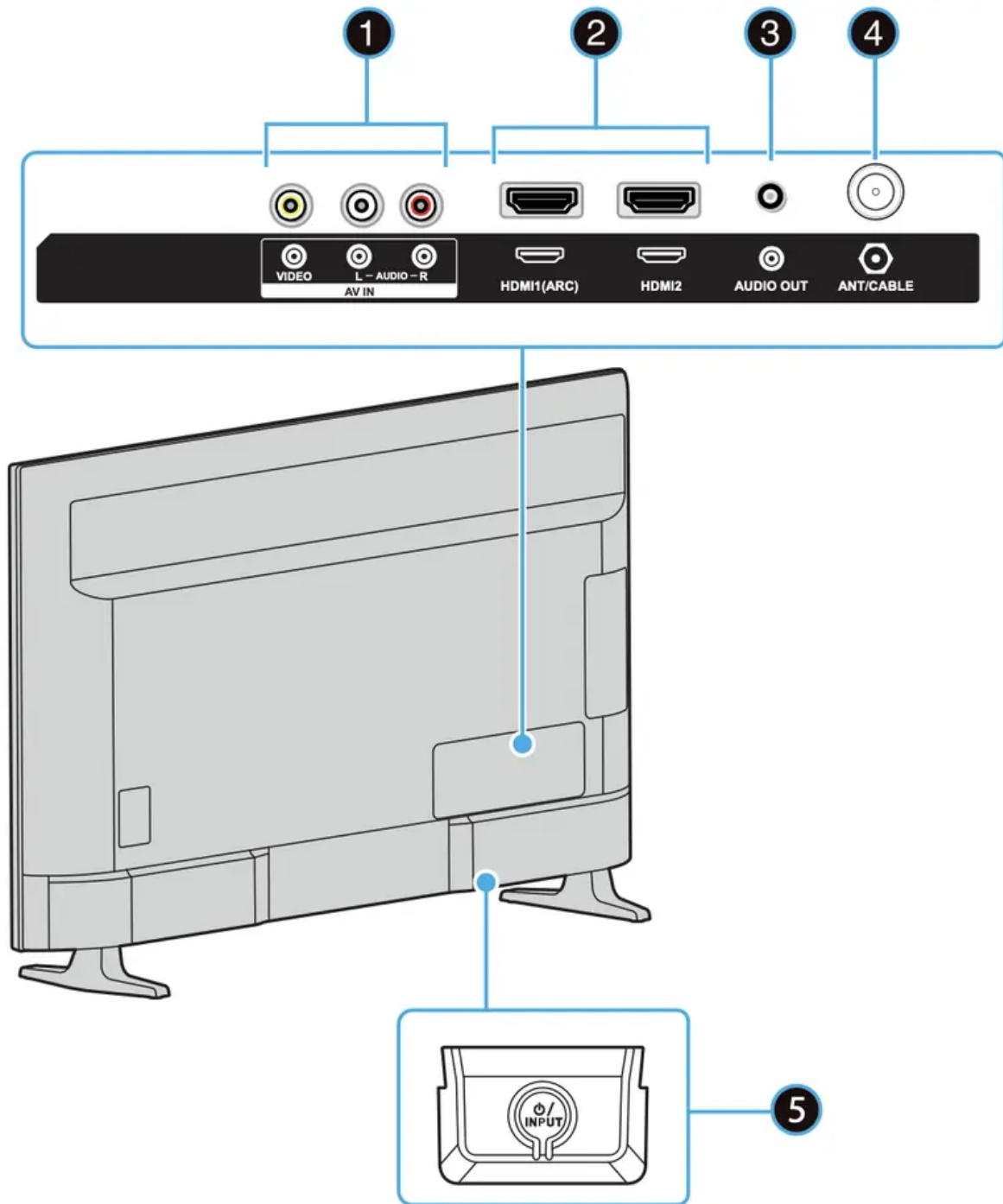

#	Item	Description
---	------	-------------

1 VIDEO/
L and R AUDIO

Connect an AV device to these jacks. For more information, see [AV \(good\)](#) on page 19, 23, or 25.

2 HDMI1(ARC)/
HDMI2

Connect HDMI® devices to these jacks. For more information, see [HDMI® \(best\)](#) on pages 18, 22, or 24 or [Connecting a computer](#) on page 26.

Connect an ARC-enabled home theater receiver to the **HDMI1(ARC)** jack. For more information, see [Digital audio using the HDMI1\(ARC\) jack](#) on page 30.

3 AUDIO OUT

Connect an analog soundbar, speaker system, or home theater system to this jack to listen to TV audio through external speakers. For more information, see [Analog audio using the AUDIO OUT jack](#) on page 31.

4 ANT/CABLE

Connect an antenna or cable TV to this jack. For more information, see [Coaxial \(good\)](#) on page 20 or [Connecting an antenna or cable TV \(no box\)](#) on page 21.

—Press to turn your TV on or off (standby mode). Press and hold to turn off your TV when TV is on.



Warning: When your TV is off, power still flows through it. To completely disconnect power, unplug the power cord.

5 /INPUT

INPUT—When your TV is on,

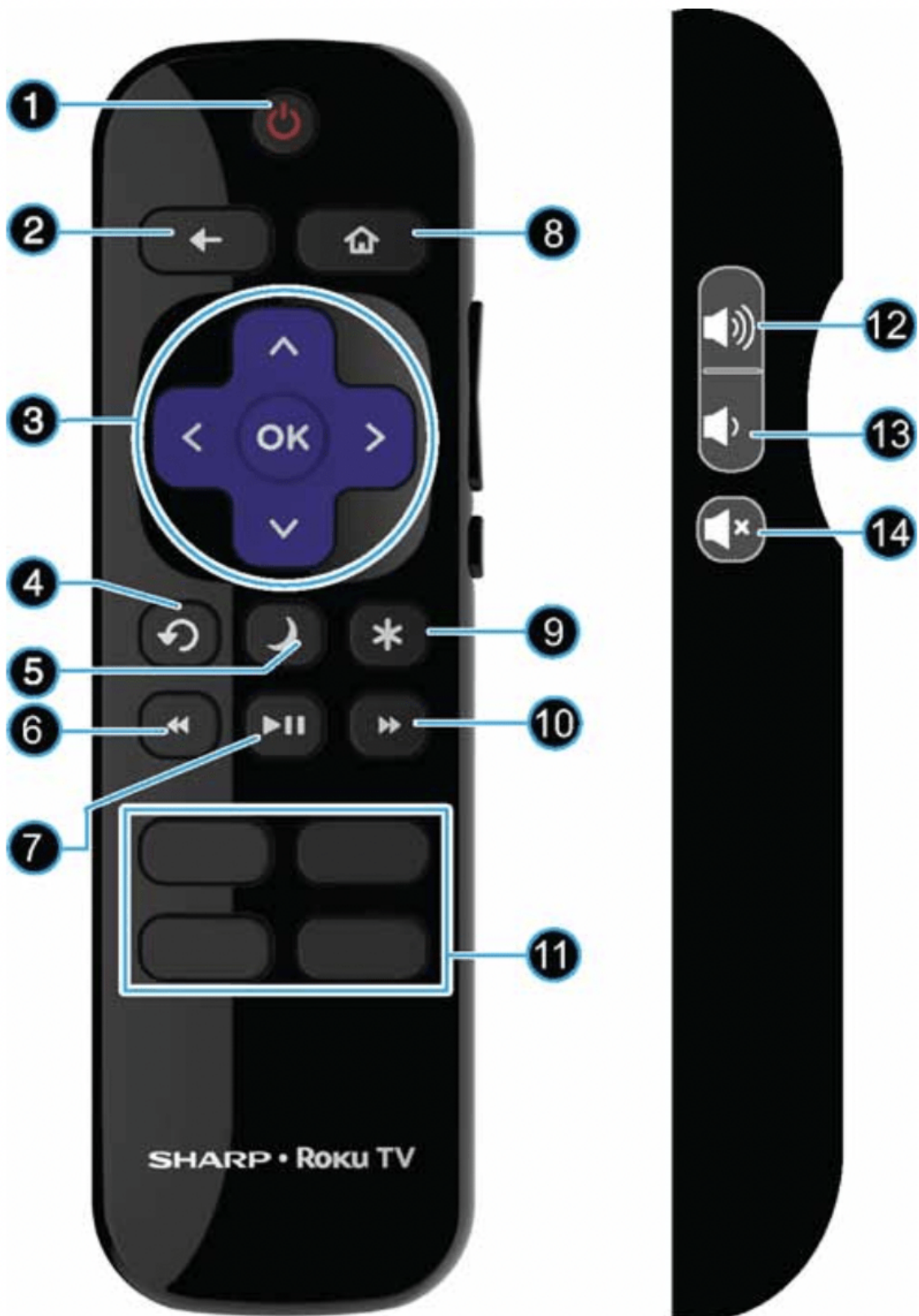
Remote control





#	Button	Description
1	 (power)	Turns your TV on or off.
2	 (back)	<p>The action depends on what you are doing with your TV:</p> <p>Menu—Goes back to the previous menu or screen.</p> <p>Home screen tile—Moves the highlight back to the Home menu option.</p> <p>Watching Antenna TV or a TV input—Returns to the screen from which the input was selected.</p> <p>Playing streaming content—Stops playing stream and returns to the previous menu or screen.</p> <p>Browsing streaming content—Goes to the previous level in the content tree.</p>

#	Button	Description
---	--------	-------------



3	 and OK	<p> \wedge / \vee—Moves the highlight up or down one item. \leftarrow—Moves the highlight left, if a \leftarrow hint appears. <ul style="list-style-type: none"> • When watching TV, displays your channel list. • When playing most streaming videos, skips backward in the video. \rightarrow—Moves the highlight to the right, if a \rightarrow hint appears. <ul style="list-style-type: none"> • When watching TV with the channel list displayed, dismisses the channel list. • When playing most streaming videos, skips forward in the video. OK—Selects the highlighted option. <ul style="list-style-type: none"> • When watching TV, displays information for the current TV program. </p>
---	--	--





4	 (previous)	<p> Watching Antenna TV or cable (no set-top box)—Changes to the previous channel. Playing streaming content—Jumps back one position in video. Menu—Backspaces one letter during menu entries, such as Search. </p>
---	--	--

5	 (sleep)	<p> First press displays a banner showing the remaining sleep time, if any, or Sleep timer is off. Subsequent presses cycle among the preset sleep time intervals: 30 minutes, 1 hour, 1.5 hours, 2 hours, and 3 hours. After it is set, the Sleep timer remains in effect regardless of what you are watching. </p>
---	---	--

6	 (rewind)	<p> When playing streaming video that supports this feature or broadcast TV if Live TV Pause is enabled, cycles through 1\times, 2\times, and 3\times rewind speeds. When playing streaming audio, jumps to the previous track/selection. When any menu, tile, or channel in the channel list is highlighted, jumps up one page. When using a virtual keyboard, jumps to the character at the top of the current column. </p>
---	--	---

7	 (play/pause)	<p> Pauses and plays streaming content. </p>
---	--	--

#	Button	Description
11	Streaming Channels Shortcuts	<p>Dedicated buttons show the logo of a featured streaming content provider. Pressing a button turns your TV on (if your TV is not already on), and if your TV is operating and is connected to the Internet, performs one of the following actions:</p> <ul style="list-style-type: none"> • Displays the streaming channel's main page if you have already added the channel to your Home screen. • Displays the streaming channel's sign-up page if you have not already added the channel so that you can agree to any terms and fees for the service.
12	 (volume up)	<p>Turns the volume up one setting with each press. Press and hold to turn the volume up rapidly. A volume indicator shows the volume level while you are adjusting the volume and for a few seconds afterward.</p> <p>Note: If your TV is muted, pressing  unmutes the sound.</p>







#	Button	Description
13	 (volume down)	<p>Turns the volume down one setting with each press. Press and hold to turn the volume down rapidly. A volume indicator shows the volume level while you are adjusting the volume and for a few seconds afterward.</p> <p>Note: If your TV is muted, pressing  does not unmute the sound.</p>
14	 (mute)	<p>Mutes and unmutes the TV sound. A volume indicator shows the current volume level and a mute icon when you press  and for a few seconds afterward. If Closed captioning is set to When Mute, captions are displayed while your TV is muted.</p>

What connection should I use?

Your TV has several connection types for connecting devices to your TV.

For the best video quality, you should connect a device to the best available connection.

Use the following tables to identify cables:

Video quality	Connection type and jack	Cable connector
Best (use this if your devices have HDMI®)	HDMI® video/audio 	
Good	AV (composite video) (requires an audio connection) 	
Good	Coaxial video/audio 	

Connection type and jack

Cable connector

Digital optical audio output



Analog audio input



3.5mm analog audio output



Cautions

- Check the jacks for position and type before making any connections.
- Loose connections can cause poor audio or video quality. Make sure that all connections are tight and secure.
- The external audio/video devices shown may be different from your devices. If you have questions, refer to the documentation that came with your devices.

- Always turn off your TV when connecting external devices.

Connecting a cable or satellite box

Many cable or satellite TV boxes have more than one connection type. To get the best video, you should use the best connection type available. For more information, see *What connection should I use?* on page 17.

You can connect your cable or satellite box using:



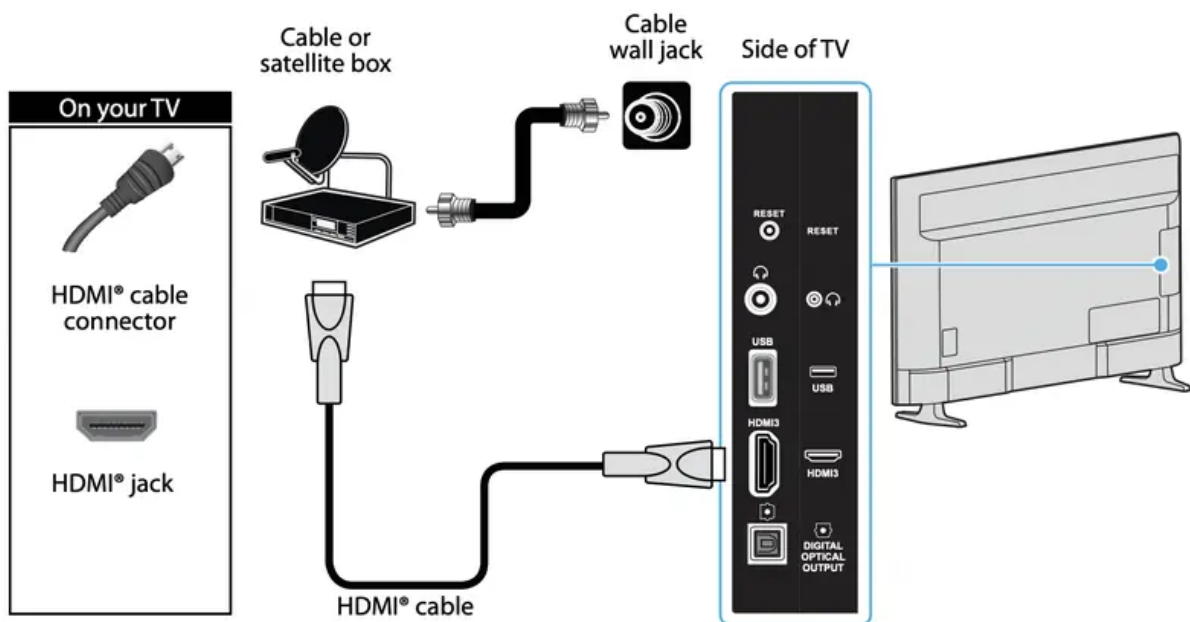

- HDMI® (best)
- AV (good)
- Coaxial (good)

HDMI® (best)

Note: For better picture quality, we recommend that you use cables designated as High Speed HDMI® cables.



1. Make sure that your TV's power cord is unplugged and all connected devices are turned off.
2. Connect the incoming cable from the cable wall jack to the cable-in jack on the cable or satellite box.
3. Connect an HDMI® cable (not provided) to an HDMI jack on side or back of your TV and to the HDMI OUT jack on the cable or satellite box.
4. Plug your TV's power cord into a power outlet, turn on your TV, then turn on the cable or satellite box.

5. On the Home screen, press    or  to highlight the HDMI 1, HDMI 2, or HDMI 3 tile, then press OK.

Note: An HDMI® cable carries both audio and video. You do not need to use any audio cables.



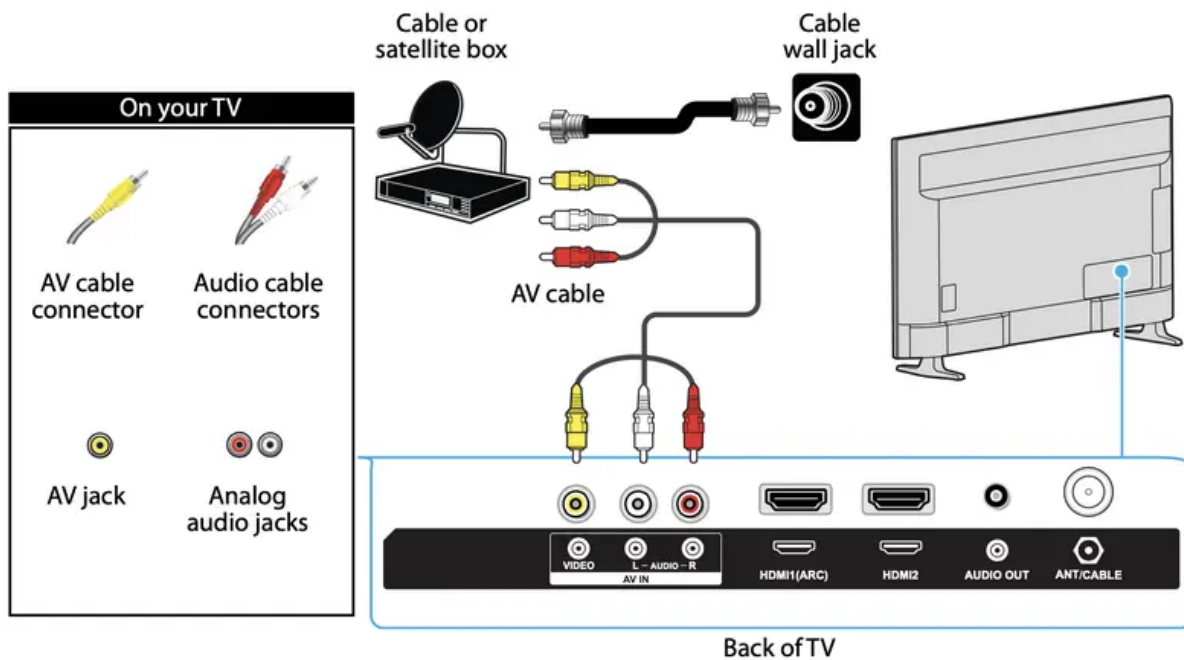

AV (good)

Notes: Cables are often color-coded to match color-coded jacks.



1. Make sure that your TV's power cord is unplugged and all connected devices are turned off.
2. Connect the incoming cable from the cable wall jack to the cable-in jack on the cable or satellite box.
3. Connect an AV cable (not provided) to the VIDEO jack and L and R AUDIO jacks on the back of your TV and to the AV and audio out jacks on the cable or satellite box.
Note: When you connect the audio using the L and R AUDIO jacks, the audio output is analog.

4. Plug your TV's power cord into a power outlet, turn on your TV, then turn on the cable or satellite box.

5. On the Home screen, press    or  to highlight the AV tile, then press OK.

Coaxial (good)

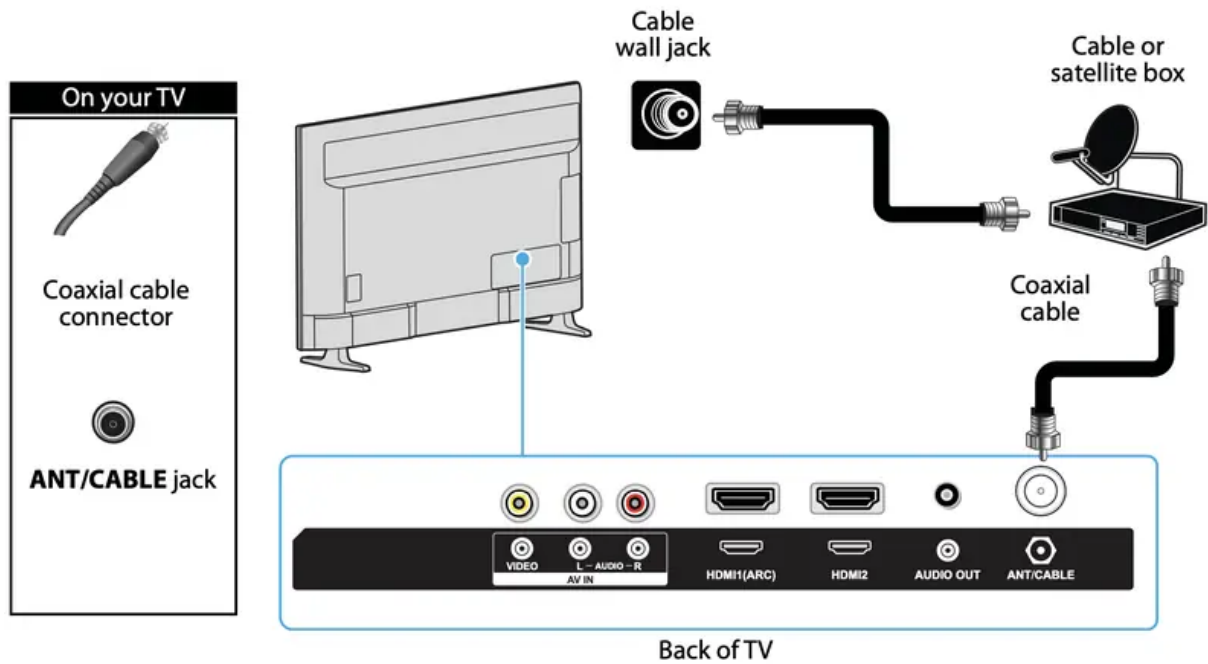





1. Make sure that your TV's power cord is unplugged and all connected devices are turned off.
2. Connect the incoming cable from the cable wall jack to the cable-in jack on the cable or satellite box.
3. Connect a coaxial cable (not provided) to the ANT/CABLE jack on the back of your TV and to the coaxial out jack on the cable or satellite box.
4. Plug your TV's power cord into a power outlet, turn on your TV, then turn on the cable or satellite box.
5. On the Home screen, press **^** **v** **<** or **>** to highlight the Antenna TV tile, then press OK. If you have not set up the TV tuner, follow the on-screen instructions.

Notes

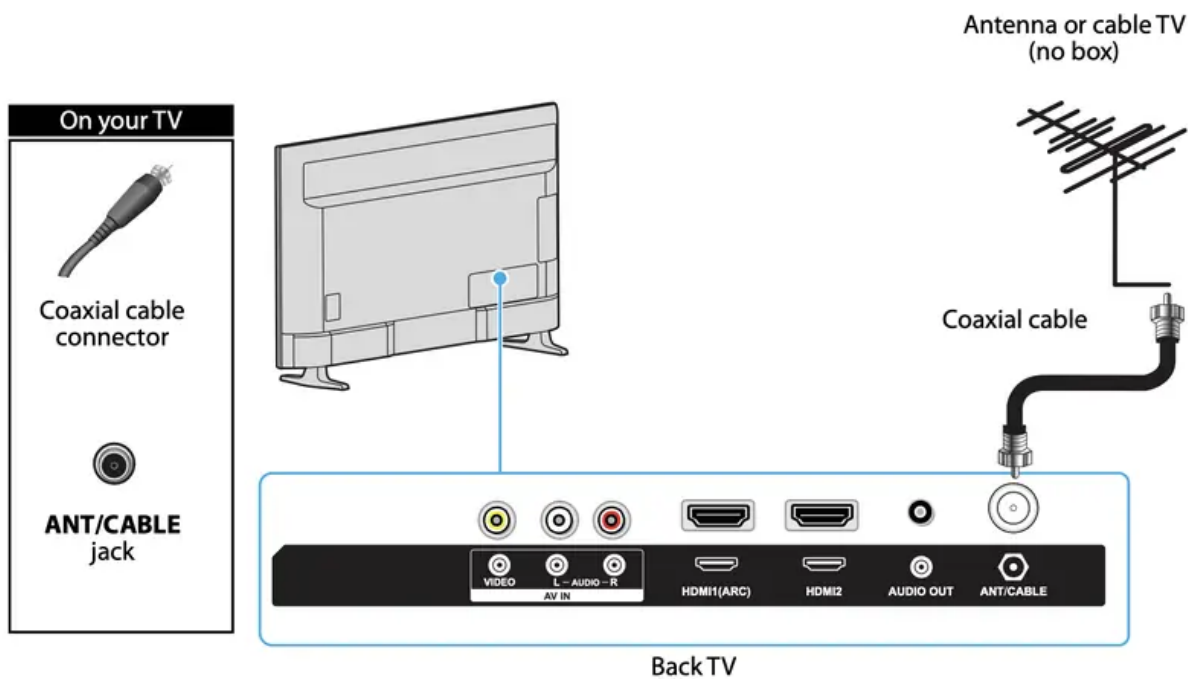
- Use a coaxial cable to eliminate interference and noise from radio waves.
- Do not bundle the coaxial cable with the power cord or other cables.

Connecting an antenna or cable TV (no box)



1. Make sure that your TV's power cord is unplugged and all connected devices are turned off.
2. Connect a coaxial cable (not provided) to the ANT/CABLE IN jack on the back of your TV and to the antenna or cable TV wall jack.
3. Plug your TV's power cord into a power outlet, then turn on your TV.
4. On the Home screen, press    or  to highlight the Antenna TV tile, then press OK. If you have not set up the TV tuner, follow the on-screen instructions.

Notes

- Use a coaxial cable to eliminate interference and noise from radio waves.
- Do not bundle the coaxial cable with the power cord or other cables.
- If the antenna is not installed correctly, contact qualified service personnel to correct the problem.
- If the signal level for a channel is weak, the picture may be distorted. Adjust the antenna or use a highly directional outdoor or set-top antenna with a built-in amplifier.
- If the picture quality is good on some channels and poor on others, the problem may be caused by a poor or weak signal from the broadcaster or cable TV provider.
- If you connect to cable TV without a set-top box and experience poor picture quality, you may need to install a set-top box to improve signal reception and picture quality. Contact your cable TV provider about upgrading to a set-top box.

- Many high-definition (HD) channels upscale standard-definition (SD) content. The picture displayed on your TV is still displayed as SD, thus the picture quality will not be as clear or crisp as it would be if the content was originally recorded in HD.

Connecting a DVD or Blu-ray player

Many DVD or Blu-ray players have more than one connection type. To get the best video, you should use the best connection type available. For more information, see What connection should I use? on page 17.





You can connect a DVD or Blu-ray player using:

- HDMI® (best)
- AV (good)

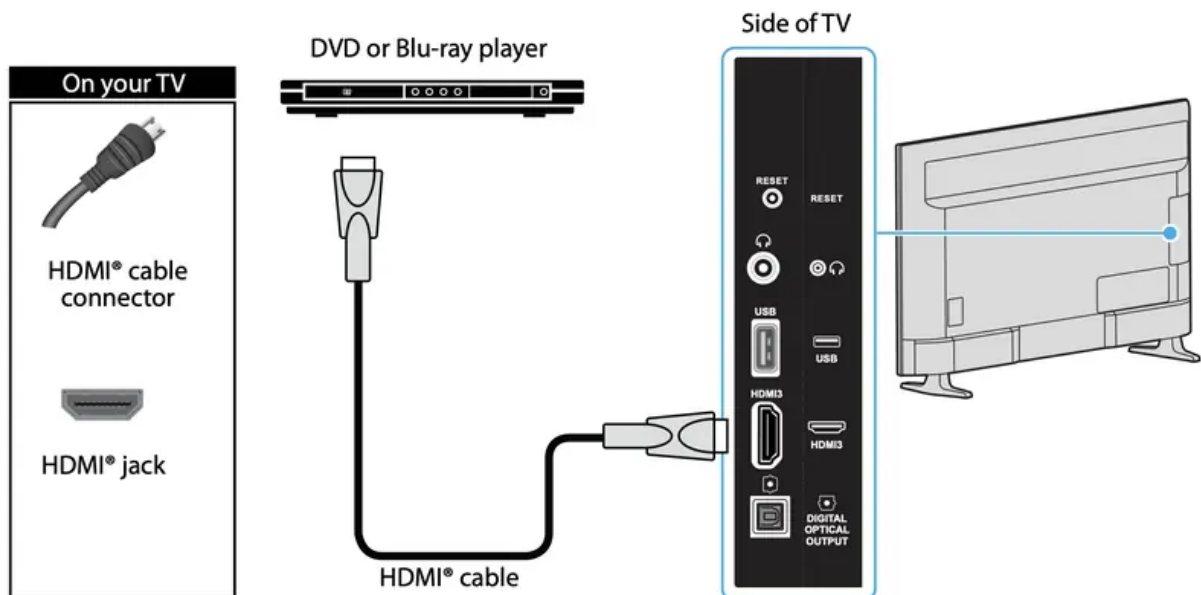
HDMI® (best)

Note: For better picture quality, we recommend that you use cables designated as High Speed HDMI® cables.







1. Make sure that your TV's power cord is unplugged and the DVD or Blu-ray player is turned off.
2. Connect an HDMI® cable (not provided) to an HDMI jack on the side or back of your TV and to the HDMI OUT jack on the DVD or Blu-ray player.
3. Plug your TV's power cord into a power outlet, then turn on your TV and DVD or Blu-ray player.
4. On the Home screen, press    or  to highlight the HDMI 1, HDMI 2, or HDMI 3 tile, then press OK.

Note: An HDMI® cable carries both audio and video. You do not need to use any audio cables.

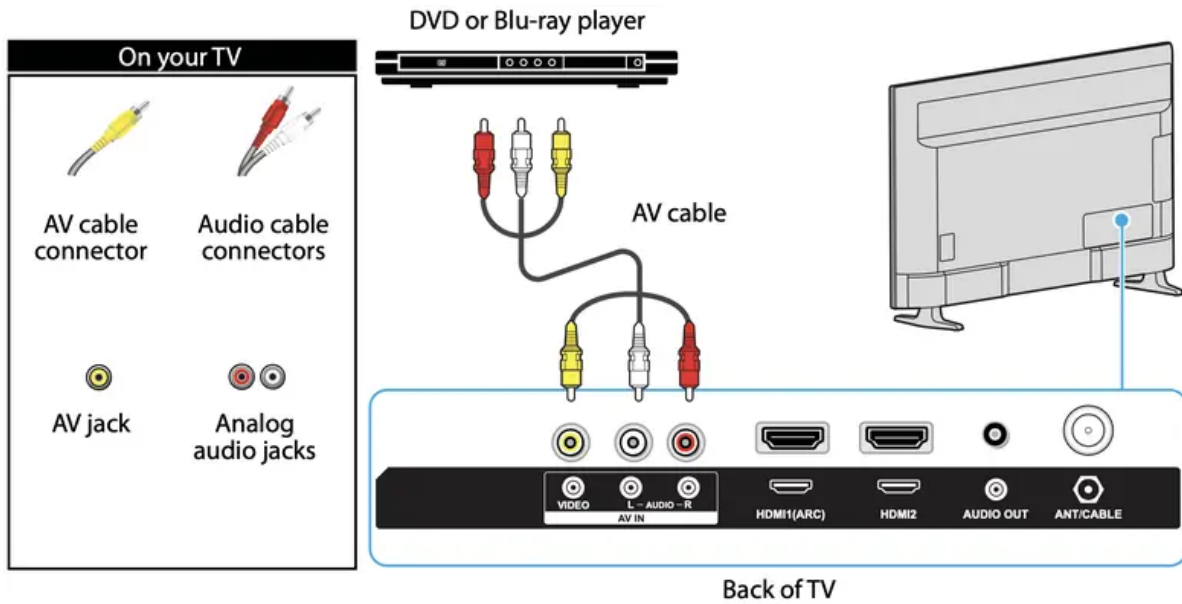
AV (good)

Note: Cables are often color-coded to match color-coded jacks.



1. Make sure that your TV's power cord is unplugged and the DVD or Blu-ray player is turned off.
2. Connect an AV cable (not provided) to the VIDEO jack and L and R AUDIO jacks on the back your TV and to the AV OUT jacks on the DVD or Blu-ray player.
Note: When you connect the audio using the L and R AUDIO jacks, the audio output is analog.
3. Plug your TV's power cord into a power outlet, then turn on your TV and DVD or Blu-ray player. 4 On the Home screen, press    or  to highlight the AV tile, then press OK.

Connecting a game console

Many game consoles have more than one connection type. To get the best video, you should use the best connection type available. For more information, see What connection should I use? on page 17.





You can connect a game console using:

- HDMI® (best)
- AV (good)

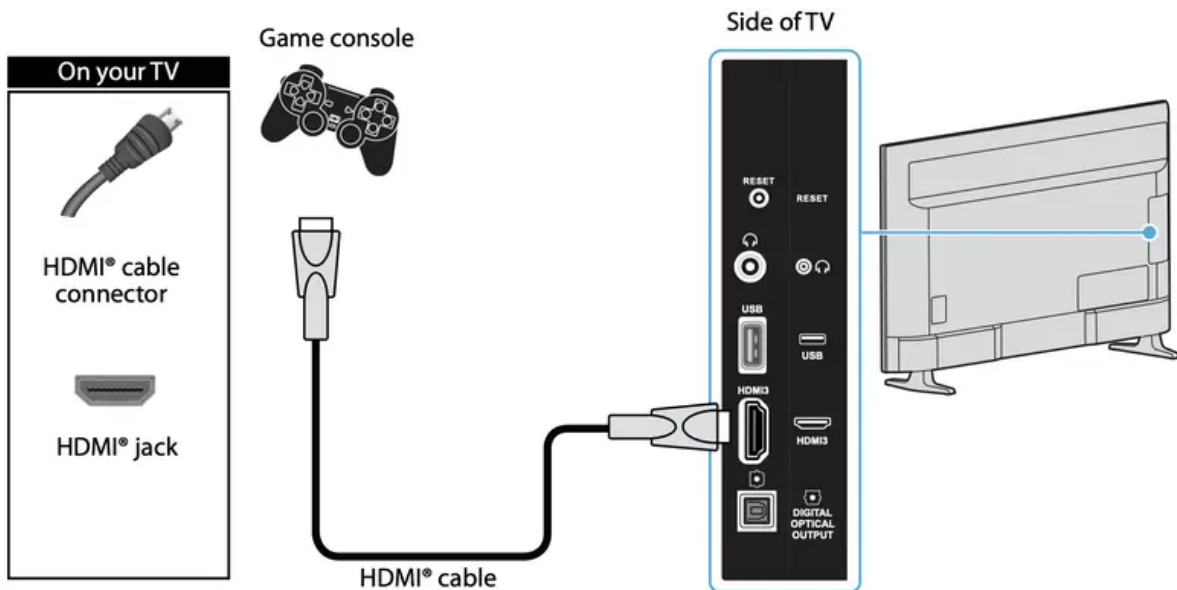
HDMI® (best)

Note: For better picture quality, we recommend that you use cables designated as High Speed HDMI® cables.



1. Make sure that your TV's power cord is unplugged and the game console is turned off.
2. Connect an HDMI® cable (not provided) to an HDMI jack on the side or back of your TV and to the HDMI OUT jack on the game console.
3. Plug your TV's power cord into a power outlet, then turn on your TV and the game console.
4. On the Home screen, press    or  to highlight the HDMI 1, HDMI 2, or HDMI 3 tile, then press OK.

Note: An HDMI® cable carries both audio and video. You do not need to use any audio cables.

AV (good)

Note: Cables are often color-coded to match color-coded jacks.

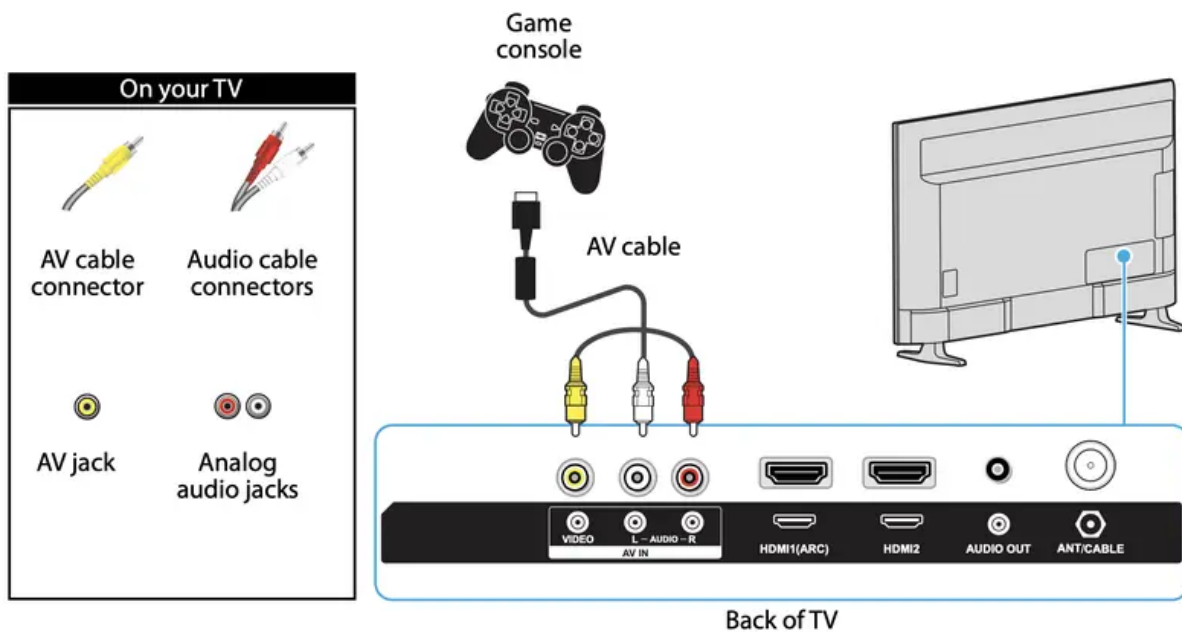





1. Make sure that your TV's power cord is unplugged and the game console is turned off.
2. Connect the game console's AV cable (not provided) to the VIDEO jack and L and R AUDIO jacks on the back of your TV and to the AV jack(s) on the game console.

Note:

Some older game consoles come with a special AV cable. See the documentation that came with your game console or check the manufacturer's website.

When you connect the audio using the L and R AUDIO jacks, the audio output is analog.

3. Plug your TV's power cord into a power outlet, then turn on your TV and the game console.
4. On the Home screen, press    or  to highlight the AV tile, then press OK.

Connecting a computer

You can use an HDMI® jack on your TV to connect to a computer.

Note: For better picture quality, we recommend that you use cables designated as High Speed HDMI® cables.

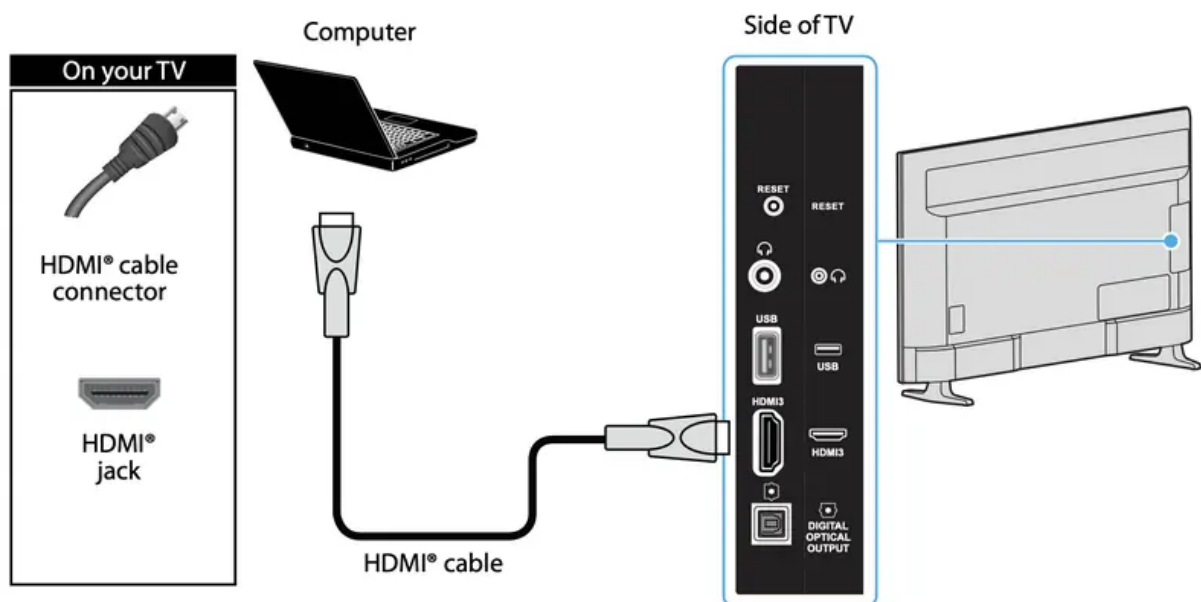



1. Make sure that your TV's power cord is unplugged and the computer is turned off.
2. Connect an HDMI® cable (not provided) to an HDMI jack on the side or back of your TV and to the HDMI OUT jack on the computer.
3. Plug your TV's power cord into a power outlet, then turn on your TV and the computer.
4. On the Home screen, press **^** **v** **<** or **>** to highlight the HDMI 1, HDMI 2, or HDMI 3 tile, then press OK.
5. Adjust the display properties on the computer, if necessary.

Connecting a USB flash drive

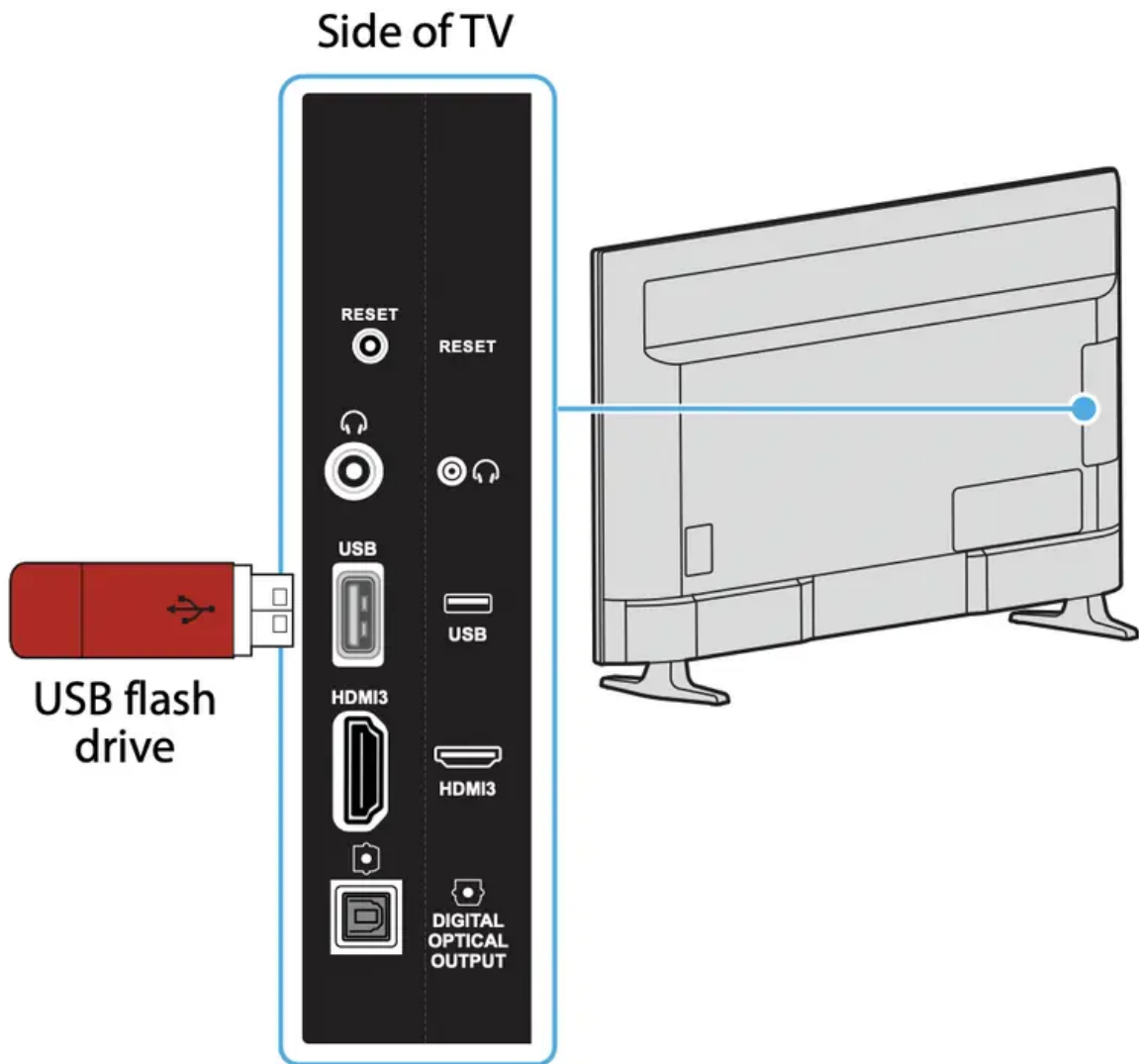
When you connect a USB flash drive to the USB jack on your TV, you can view photos and videos or listen to music stored on the drive or you can use the Live TV Pause feature to pause live TV for up to 90 minutes.





1. Plug a USB flash drive into the USB port on the side of your TV.
Caution: Do not remove the USB flash drive or turn off your TV while using the USB flash drive. You may lose data or damage the USB flash drive.
2. Press  or  to highlight the Roku Media Player or USB Media Player tile, then press OK.

Connecting headphones

When you connect headphones, your TV speakers are muted and sound only plays through the headphones.

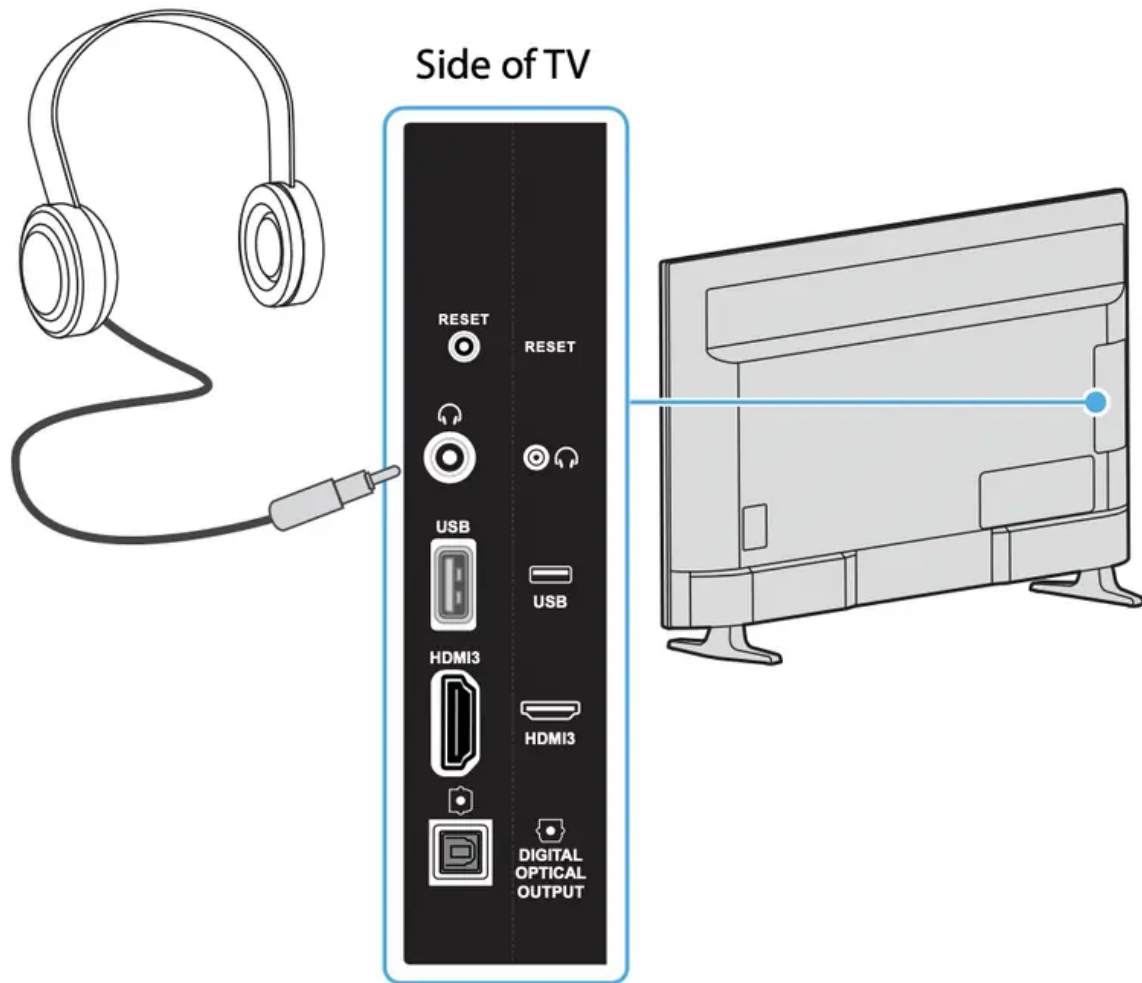
Warning: Loud noise can damage your hearing. When using headphones, use the lowest volume setting on your headphones that still lets you hear the sound.



Connect the headphones to the  jack on the side of your TV.

Note: You can also connect a home theater system, sound bar, or external speaker system to the  jack.

Connecting external speakers or a sound bar

When you connect external speakers or a sound bar, sound plays through your TV speakers and the external speakers or sound bar.

You can connect external speakers or a sound bar using:

- Digital audio using the DIGITAL OUTPUT (OPTICAL) jack
- Digital audio using the HDMI1(ARC) jack
- Analog audio using the AUDIO OUT jack

Digital audio using the DIGITAL OUTPUT (OPTICAL) jack

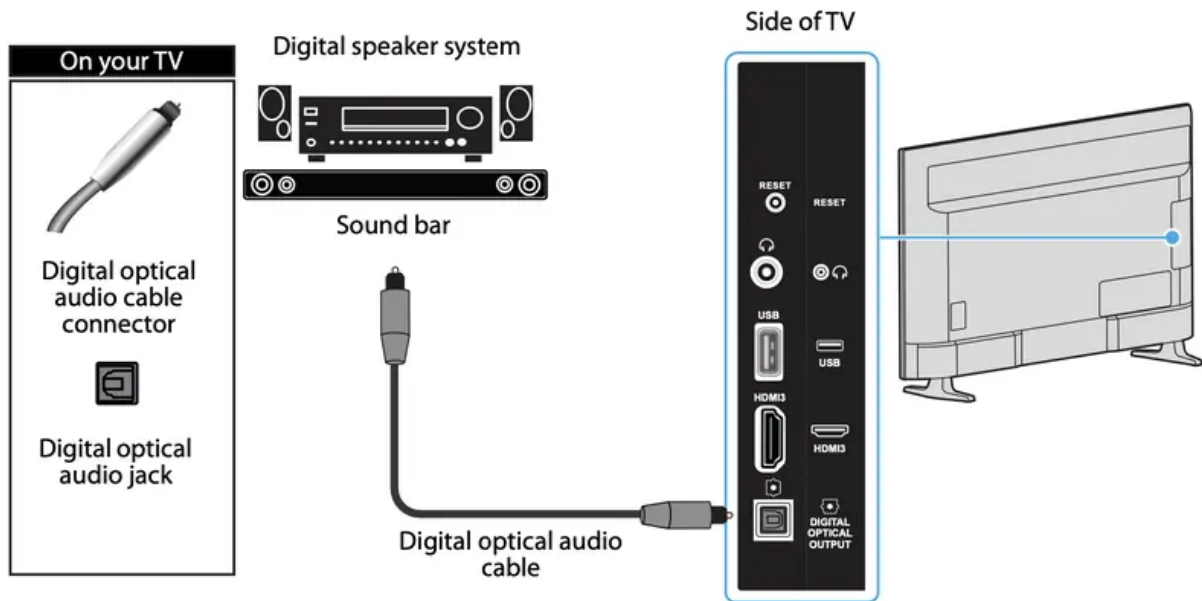

1. Make sure that your TV's power cord is unplugged and the digital speaker system or sound bar is turned off.
2. Connect a digital optical audio cable (not provided) to the DIGITAL OUTPUT (OPTICAL) jack on the side of your TV and to the digital optical AUDIO IN jack on the digital speaker system or sound bar.
3. Plug your TV's power cord into a power outlet, then turn on your TV.
4. Turn on the digital speaker system or sound bar, then set it to the correct source. For more information, see the documentation that came with the digital speaker system or sound bar.
5. To turn off your TV speakers, on the Home menu, press \wedge or \vee to highlight Settings, then press OK. Highlight Audio, then press OK. Highlight TV speakers, then press OK. Press OK to remove the check from the TV speakers enabled check box.

Digital audio using the HDMI1(ARC) jack

Your TV can send sound to an ARC device, like an AV receiver, to create a home theater that uses two or more speakers. When you connect external speakers or a sound bar, sound plays through your TV speakers and the external speakers or sound bar.

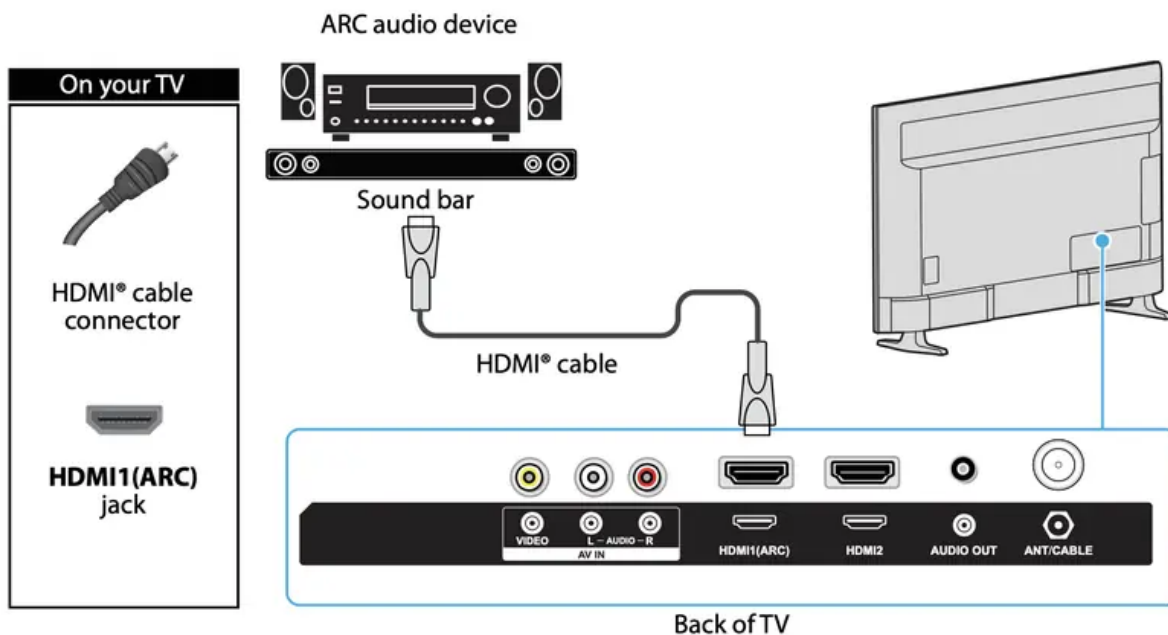

1. Make sure that your TV's power cord is unplugged and the digital speaker system or sound bar is turned off.
2. Connect an HDMI® cable (not provided) to the HDMI1(ARC) jack on the back of your TV and to the HDMI IN jack on the digital speaker system or sound bar.
3. Plug your TV's power cord into a power outlet, then turn on your TV.
4. Turn on the digital speaker system or sound bar, then set it to the correct source. For more information, see the documentation that came with the digital speaker system or sound bar.
5. To turn off your TV speakers, on the Home menu, press \wedge or \vee to highlight Settings, then press OK. Highlight Audio, then press OK. Highlight TV speakers, then press OK. Press OK to remove the check from the TV speakers enabled check box.
6. To configure the HDMI1(ARC) jack to output sound to an ARC device, on the Home menu, press \wedge or \vee to highlight Settings, then press OK. Highlight System, then press OK. Highlight Control other devices (CEC), then press OK. Highlight HDMI ARC, then press OK to check the box.

Analog audio using the AUDIO OUT jack

When you connect an analog speaker system or soundbar to the AUDIO OUT jack, sound plays through the TV speakers and the audio device.

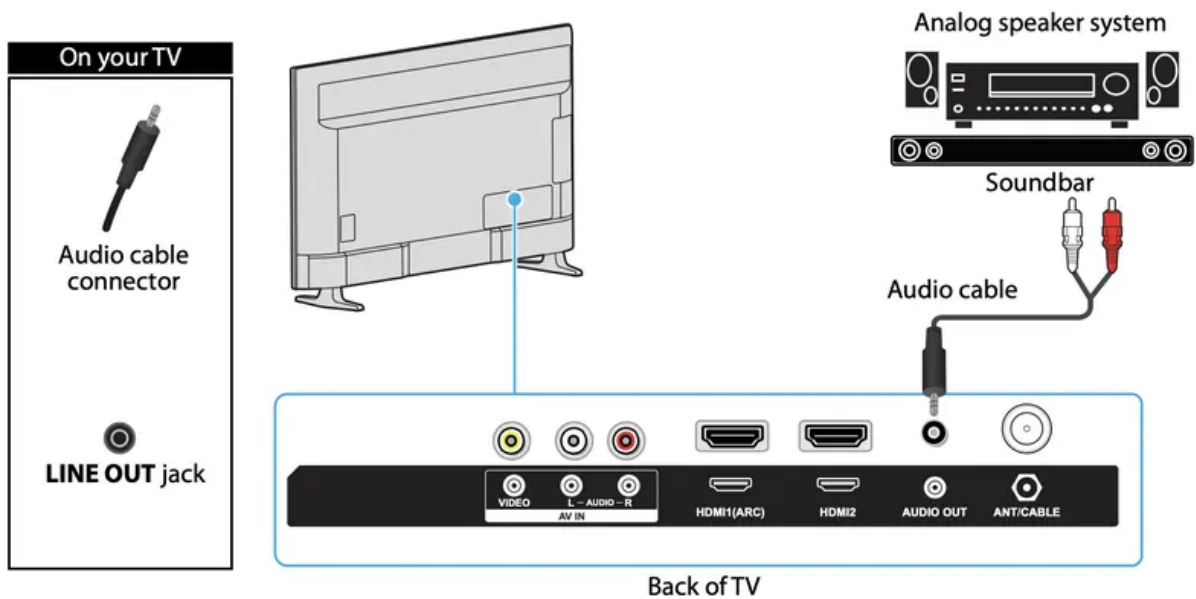

1. Make sure that your TV's power cord is unplugged and the analog speaker system or soundbar is turned off.
2. Connect an audio cable (not provided) to the AUDIO OUT jack on the back of your TV and to the AUDIO IN jacks on the analog speaker system or soundbar.
3. Plug your TV's power cord into a power outlet, then turn on your TV.
4. Turn on the analog speaker system or soundbar, then set it to the correct source. For more information, see the documentation that came with the analog speaker system or soundbar.
5. To turn off your TV speakers, on the Home menu, press \wedge or \vee to highlight Settings, then press OK. Highlight Audio, then press OK. Highlight TV speakers, then press OK. Press OK to remove the check from the TV speakers enabled check box.

Note: Use the volume controls on the analog speaker system or soundbar to control the volume.

Connecting a home theater system with multiple devices

You can connect an AV receiver and your devices to create a home theater.

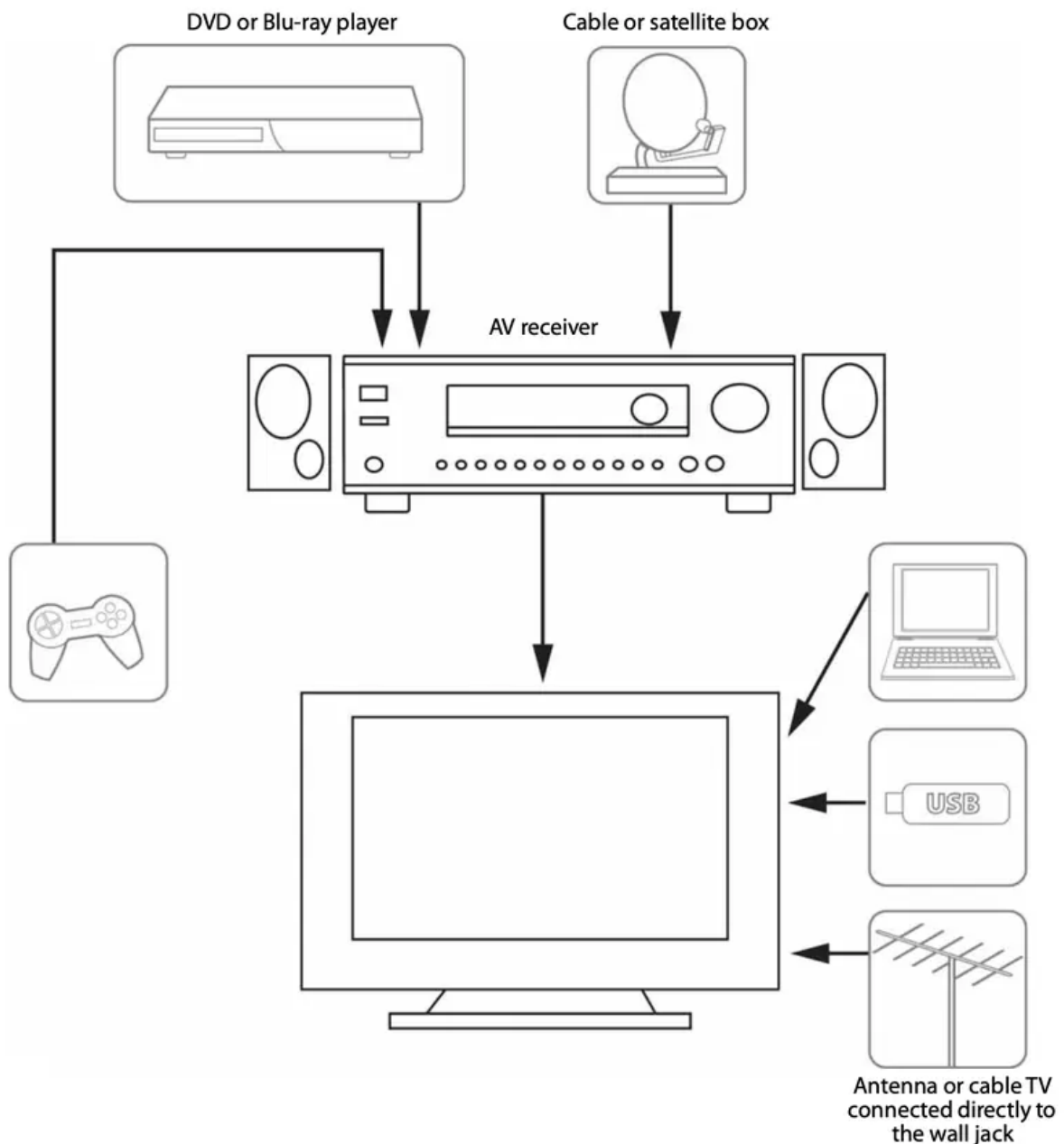

The connections you make depend on the video and audio jacks available on your devices. Refer to the documentation that came with your devices for connection information.

Just remember to use the best connection types available for the best picture and sound. For information about connection types, see [What connection should I use?](#) on page 17.

Connecting power

You should connect devices before you connect the power cord. When you are adding devices, make sure that the power cord is unplugged from the power outlet.

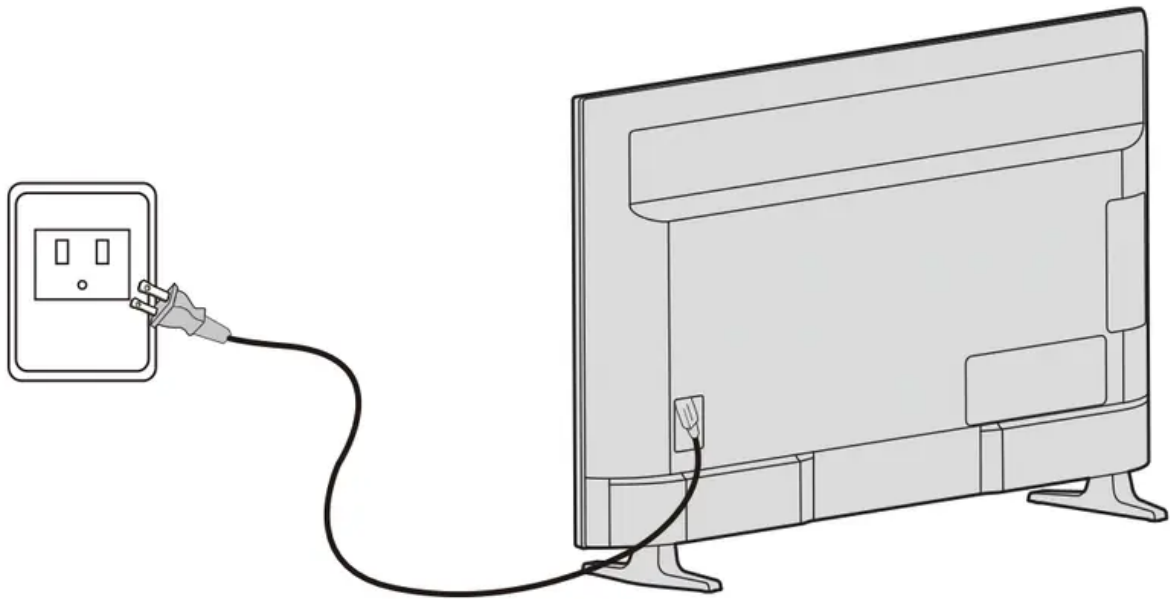

1. Connect the power cord to the power connector on the back of your TV.
2. Connect the other end of the cord to a power outlet.

Caution

- Your TV should only be operated from the power source indicated on the label.
- Always unplug the power cord from the power outlet when you will not be using your TV for an extended period of time.

Setting up your TV

When you turn on your TV for the first time, Guided Setup starts. During Guided Setup:

- Your TV automatically detects your wireless network, so have your network name and password handy and follow the easy on-screen instructions.
- You'll be prompted to create your Roku account online at <https://my.roku.com/link>. Your TV generates a unique code that links your TV to your new account.

Note: Roku accounts are free, and while a valid credit card number is not required, providing your card information makes renting and purchasing entertainment a breeze.

- After you are connected to your account, your TV automatically updates with the latest software, and you can start streaming immediately.

Note: If you aren't ready to connect your TV to a wireless network, you can still use it as a regular TV.

Maintaining

- Do not use your TV in areas that are too hot or too cold, because the cabinet may warp or the screen may malfunction. Your TV works best in temperatures that are comfortable to you.
- Storage temperatures are 5° to 113°F (-15°to 45°C).
- Working temperatures are 41° to 95°F (5°to 35°C).
- Do not place your TV in direct sunlight or near a heat source.

Cleaning your TV cabinet

Clean the cabinet with a soft, lint-free cloth. If the cabinet is especially dirty, moisten a soft, lint-free cloth in a weak detergent solution, squeeze the excess moisture from the cloth, then wipe the cabinet with the cloth. Use a clean cloth to dry the cabinet.

Cleaning your TV screen

Clean the screen with a soft, lint-free cloth.

Troubleshooting

Warning: Do not try to repair your TV yourself. Contact authorized service personnel.

Note: If the problem is not solved by using these troubleshooting instructions, turn off your TV, then turn it on again.

Video and audio

Symptom	Possible cause	Try this...
Picture does not fill the screen or there are black bars around the picture	The picture size may need to be adjusted	<ul style="list-style-type: none"> • Adjust the picture size (aspect ratio). See the Picture Size option in the Options menu.
I don't see a picture when I select an input	TV is not on	<ul style="list-style-type: none"> • Make sure that your TV is plugged into a working power outlet, and that your TV is turned on. (Your TV has a light on the front that indicates if your TV is turned off.)
	Cables are not connected correctly	<ul style="list-style-type: none"> • Make sure that the video cables are connected correctly and securely to your TV. • Make sure that the antenna or cable TV is connected correctly and securely. See Connecting a cable or satellite box on page 18 or Connecting an antenna or cable TV (no box) on page 21.
	Picture settings may be incorrect	<ul style="list-style-type: none"> • Adjust the contrast and brightness. See the TV brightness option in the Settings menu or Options menu. • Adjust the TV picture.
	Incorrect input may be selected	<ul style="list-style-type: none"> • Make sure that the correct input is selected for the device you want to view.
	Input source not detected	<ul style="list-style-type: none"> • Make sure that the device connected to the input is turned on. • Make sure that the cord to and from the device is connected firmly and correctly to the device and your TV.

	TV input may be bad	<ul style="list-style-type: none"> • Connect a different device to the same input and check to see if it works correctly.
TV channel does not appear	Broadcast TV may be experiencing problems or may not be set up	<ul style="list-style-type: none"> • Try another channel. The station may be experiencing problems. • Make sure that the incoming signal is compatible. • If you are trying to watch broadcast TV, make sure that Antenna TV is set up.
Dark, poor, or no picture (screen is lit), but sound is good	Broadcast TV may be experiencing problems or may not be set up	<ul style="list-style-type: none"> • Try another channel. The station may be experiencing problems. • If you are using an antenna and the signal strength is low, adjust the antenna or use a highly directional outdoor antenna or set-top antenna with a built-in amplifier.
	Cables may not be connected correctly	<ul style="list-style-type: none"> • Make sure that the antenna or cable TV is connected correctly and securely. See Connecting a cable or satellite box on page 18 or Connecting an antenna or cable TV (no box) on page 21. • Make sure that the video cables are connected correctly and securely to your TV. • The video cable(s) you are using may be bad. Try a new set.
	Picture settings may be incorrect	<ul style="list-style-type: none"> • Adjust the brightness. See the TV brightness option in the Settings menu or Options menu. • Change to a different picture mode. See the Picture mode option in the Options menu or Advanced Picture Settings menu.

No color, dark picture, or color is not correct	Picture settings may be incorrect	<ul style="list-style-type: none"> • Adjust the contrast, color, and brightness settings. See the TV brightness option in the Settings menu or the Options menu.
	Broadcast TV may be experiencing problems	<ul style="list-style-type: none"> • Try another channel. The station may be experiencing problems. • If you are using an antenna and the signal strength is low, adjust the antenna or use a highly directional outdoor antenna or set-top antenna with a built-in amplifier.
	Cables are not connected correctly	<ul style="list-style-type: none"> • Make sure that the antenna or cable TV is connected correctly and securely. See Connecting a cable or satellite box on page 18 or Connecting an antenna or cable TV (nobox) on page 21. • Make sure that the video cables are connected correctly and securely to your TV. • The video cable(s) you are using may be bad. Try a new set.
Only snow (noise) appears on the screen	Broadcast TV may be experiencing problems or may not be set up	<ul style="list-style-type: none"> • Try another channel. The station may be experiencing problems. • If you are trying to watch broadcast TV, make sure that Antenna TV is set up. • If you are using an antenna and the signal strength is low, adjust the antenna or use a highly directional outdoor antenna or set-top antenna with a built-in amplifier.
	Cables may not be connected correctly	<ul style="list-style-type: none"> • Make sure that the antenna or cable TV is connected correctly and securely. See Connecting a cable or satellite box on page 18 or Connecting an antenna or cable TV (no box) on page 21.

<p>Picture quality is good on some channels and poor on others. Sound is good</p>	<p>Broadcast signal may be weak</p>	<ul style="list-style-type: none"> • If you connect to cable without a set-top box and experience poor picture quality, you may need to install a set-top box to improve signal reception and picture quality. Contact your cable TV provider about upgrading to a set-top box.
<p>Dotted lines or stripes appear on the screen</p>	<p>Cables may not be connected correctly</p>	<ul style="list-style-type: none"> • Make sure that the antenna or cable TV is connected correctly and securely. See Connecting a cable or satellite box on page 18 or Connecting an antenna or cable TV (no box) on page 21. • Make sure that the video cables are connected correctly and securely to your TV. • The video cable(s) you are using may be bad. Try a new set.
	<p>Broadcast signal may be weak</p>	<ul style="list-style-type: none"> • If you are using an antenna and the signal strength is low, adjust the antenna or use a highly directional outdoor antenna or set-top antenna with a built-in amplifier. • Other devices (for example, a surround sound receiver, external speakers, fans, or hair dryers) maybe interfering with your TV. Try turning off one device at a time to determine which device is causing interference. After you have determined which device is causing interference, move it further from your TV to eliminate the interference.
<p>Double images</p>	<p>Broadcast signal may be weak</p>	<ul style="list-style-type: none"> • If you are using an antenna and the signal strength is low, adjust the antenna or use a highly directional outdoor antenna or set-top antenna with a built-in amplifier. • If you are using an antenna and the signal strength is low, switch to a cable or satellite box.

The picture has a few bright or dark spots	This is normal in LED TVs	<ul style="list-style-type: none"> • A few bright or dark spots on an TV screen is normal. It does not affect the operation of your TV.
Good picture, but no sound	Volume is down or muted	<ul style="list-style-type: none"> • Increase the volume. • Make sure that the sound is not muted.
	Headphones may be connected	<ul style="list-style-type: none"> • Make sure that you do not have headphones connected. When headphones are connected, no sound comes from your TV speakers.
	TV speakers may be turned off	<ul style="list-style-type: none"> • If you want sound to play through your TV speakers, make sure that your TV speakers are turned on.
	You may need to change the audio mode	<ul style="list-style-type: none"> • Change to a different audio mode.
	Home theater system, soundbar, or external speaker system may not be turned on or may not be set up correctly	<ul style="list-style-type: none"> • If you are using a home theater system, soundbar, or external speaker system, make sure that it is turned on and is not muted and that it is set to the correct source. • If you connected an ARC audio device to the HDMI1/ARC jack, make sure that you have turned on the ARC feature. • If you are using a home theater system, soundbar, or external speaker system and have connected it with a digital audio cable, make sure that you have set up the digital audio connection. • Make sure that the audio cables are connected correctly and securely to your TV.

	Bad content, no audio	<ul style="list-style-type: none"> • Make sure that the selected channel or content is intended to be broadcasting with sound.
	Cables may not be connected correctly	<ul style="list-style-type: none"> • Make sure that the antenna or cable TV is connected correctly and securely. See Connecting a cable or satellite box on page 18 or Connecting an antenna or cable TV (no box) on page 21. • The audio cables you are using may be bad. Try a new set.
Poor picture	Light in the viewing area maybe interfering	<ul style="list-style-type: none"> • Make sure that the room is not too bright. Light reflecting off the screen can make the picture difficult to see.
	A connected camera or camcorder may be interfering	<ul style="list-style-type: none"> • If an S-VHS camera or a camcorder is connected while another connected device is turned on, the picture may be poor. Turn off one or more devices.
Audio noise	Other devices maybe interfering	<ul style="list-style-type: none"> • Other devices (for example, a surround sound receiver, external speakers, fans, or hair dryers) may be interfering with your TV. Try turning off one device at a time to determine which device is causing interference. After you have determined which device is causing interference, move it further from your TV to eliminate the interference.
After images appear		<ul style="list-style-type: none"> • Do not display a still image, such as a logo, game, or computer image, for an extended period of time. This can cause a permanent after-image to be burned into the screen. This type of damage is not covered by your warranty.

Remote control

Symptom	Possible cause	Try this...
My TV doesn't turn on using the remote control	No power to TV	<ul style="list-style-type: none"> • Make sure that the power cord is correctly connected to both your TV power connector and power outlet. See Connecting power on page 33. You should see an LED in the front of the TV panel when a button on the remote is pressed. If you see no LED activity, try another outlet or check your fuse box.
	Line-of-sight obstructed	<ul style="list-style-type: none"> • Make sure that no objects (or pets) are obstructing the line-of-sight from the remote control to the remote sensor on the front of your TV. See Aiming the remote control on page 34.
	Remote not responding	<ul style="list-style-type: none"> • Open the battery compartment and make sure that the batteries are seated in the correct positions (+ and - in the correct positions). See Installing remote control batteries on page 34. • Make sure that the batteries are fresh and working correctly. Replace the batteries, if necessary.
	TV frozen	<ul style="list-style-type: none"> • If the front LED is not responding, or abnormally bright, disconnect the power cord from the power outlet, wait a few seconds, then reconnect the power cord.
Trouble programming your existing universal remote control	Remote control may not be programmed correctly	<ul style="list-style-type: none"> • Refer to the User Guide that accompanied your universal remote control and contact the manufacturer if problems persist.
	Batteries may be dead	<ul style="list-style-type: none"> • Replace dead batteries with new batteries. Refer to the User Guide that accompanied your universal remote control.

General

Symptom	Possible cause	Try this...
No power	Power cord may not be connected correctly	<ul style="list-style-type: none"> • Make sure that the power cord is correctly connected to both your TV power connector and power outlet. See Connecting power on page 33. You should see an LED in the front of your TV panel when a button on the remote is pressed. If you see no LED activity, try another outlet or check your fuse box. • Unplug the power cord, wait 60 seconds, then plug the cord back in and turn on your TV.
	Other devices may be interfering	<ul style="list-style-type: none"> • Other devices (for example, a surround sound receiver, external speakers, fans, or hair dryers) maybe interfering with your TV. Try turning off one device at a time to determine which device is causing interference. After you have determined which device is causing interference, move it further from your TV to eliminate the interference.
My TV tuner does not pick up as many over-the-air channels as it should	Antenna may not be placed optimally	<ul style="list-style-type: none"> • Adjust the antenna location and rescan. Go to Settings > TV inputs > Antenna TV > Scan again for channels. • Reception can vary by channel depending on the broadcast power level of a given station. Contact your cable or satellite TV provider. • Make sure that the antenna or cable/satellite TV is connected securely to your TV. • Try replacing the cable between the antenna/ cable or cable/satellite box and your TV.
	Broadcast TV may not be set up	<ul style="list-style-type: none"> • Make sure that Antenna TV is set up.
		<ul style="list-style-type: none"> • Make sure that the channels are not blocked.



One or more channels do not display	Channels may be blocked or hidden	<ul style="list-style-type: none"> • Make sure that the channels are not hidden. The channel may have been deleted from the channel list. You can add the channel back to the channel list.
	The wrong input maybe selected	<ul style="list-style-type: none"> • Make sure that you have selected the correct input tile for the device or service you are trying touse.
	You may need to use the remote control that came with the cable or satellite box	<ul style="list-style-type: none"> • If you are using a cable or satellite box, use the remote that came with that box to change channels.
I lost my parental control PIN	Need PIN recovery	<ul style="list-style-type: none"> • You will need to factory reset your TV, as the PIN cannot be recovered or reset any other way. Go to Settings > System > Advanced system settings > Factory reset.
Some settings can not be accessed	Not all settings are available for all devices or inputs	<ul style="list-style-type: none"> • If the icon or a menu option is grayed, you can not adjust settings for the current video input mode.
TV cabinet creaks	This is normal	<ul style="list-style-type: none"> • When your TV is in use, the temperature rises naturally and may cause the cabinet to expand or contract which can cause a creaking noise. This is not a malfunction.
Control buttons do not work	TV may be frozen	<ul style="list-style-type: none"> • Unplug the power cord, wait a few seconds, then plug the cord back in and turn on your TV.
TV keeps turning off	Sleep timer may be turned on	<ul style="list-style-type: none"> • Make sure that the sleep timer is not turned on.

Some features are not available	The wrong TV mode may be selected	<ul style="list-style-type: none"> You may have Set up for store mode when you set up your TV. Store use mode is for retail environments only. In Store use mode, some of your TV's features are missing or limited. If you selected Set up for store use and you want to change to Set up for home use, you have to reset your TV to the factory defaults. Go to Settings > System > Advanced system settings > Factory reset.
---------------------------------	-----------------------------------	---

Roku

Symptom	Possible cause	Try this...
How can I find out more about using my TV?		
I can't turn my TV on with the Roku mobile app	Your TV is "asleep"	<ul style="list-style-type: none"> You will need to use the physical remote button to "wake up" or turn on your TV.
I can't find my TV with the Roku mobile app	TV and mobile app not on same wireless network	<ul style="list-style-type: none"> Make sure that your TV and the mobile app are on the same network.
	TV not powered or working normally	<ul style="list-style-type: none"> Make sure that your TV is connected to a working power outlet and that your TV is turned on. See Connecting power on page 33.

Network

Symptom	Possible cause	Try this...
I can not connect to the Internet	Network connection may not be setup	<ul style="list-style-type: none"> • If you did not connect to the Internet when you first set up your TV, set up a network connection.
	Network name or password may have changed	<ul style="list-style-type: none"> • If your network name or password has changed, you need to update your network connection.
Streaming keeps pausing to load more data	Wireless LAN not optimized	<ul style="list-style-type: none"> • Rotate wireless router slightly • Elevate the router • Turn off other wireless connections • Use 5.0Ghz, if possible. Roku TVs support dual band.
	Insufficient broadband speed	<ul style="list-style-type: none"> • Turn off other wireless connections that may also be using band width.

CEC-compatible devices



Symptom	Possible cause	Try this...
My TV is not displaying the video from the connected CEC device	Cables may not be connected correctly	<ul style="list-style-type: none"> • Make sure that the HDMI® cable is connected securely to your TV and the device. • Make sure that the device is connected to your TV with an HDMI® cable.
	Picture settings may be incorrect	<ul style="list-style-type: none"> • Try adjusting your TV picture.
	The selected input may be incorrect	<ul style="list-style-type: none"> • Make sure that the correct input tile is selected.
	Connected device may not be a CEC device	<ul style="list-style-type: none"> • Make sure that the device is a CEC device. See the documentation that came with the device for more information.
	CEC control may not be setup correctly	<ul style="list-style-type: none"> • Make sure that your TV has searched for CEC devices.
My TV is not playing the audio from the connected CEC device.	Cables may not be connected correctly	<ul style="list-style-type: none"> • Make sure that the HDMI® cable is connected securely to your TV and the device.
	Volume may be too low or muted	<ul style="list-style-type: none"> • Make sure that the volume on your TV and the device is turned up and not muted.
	TV speakers may be turned off	<ul style="list-style-type: none"> • If you want sound to play through your TV speakers, make sure that your TV speakers are turned on.
	Connected device may not be a CEC device	<ul style="list-style-type: none"> • Make sure that the device is a CEC device. See the documentation that came with the device.



	CEC control may not be setup correctly	<ul style="list-style-type: none"> • Make sure that your TV has searched for CEC devices.
	Connected audio device may not be set up correctly	<ul style="list-style-type: none"> • If you are using a home theater system, soundbar, or external speaker system, make sure that it is set to the correct source. • If you are using a home theater system, soundbar, or external speaker system and have connected it with a digital audio cable, make sure that you have set up digital audio. • If you connected an ARC audio device to the HDMI1/ARC jack, make sure that you have turned on the ARC feature.
My TV's remote control does not control the device	Connected device may not be turned on	<ul style="list-style-type: none"> • Make sure that the device is turned on.
	Line-of-sight obstructed	<ul style="list-style-type: none"> • Make sure that no objects (or pets) are obstructing the line-of-sight from the remote control to the remote sensor on the front of your TV and the device.
	Connected device may not support some or all CEC features	<ul style="list-style-type: none"> • Depending on the device, all the buttons may not work. • The device may not support this feature. See the documentation that came with the device for more information.
	CEC control may not be setup correctly	<ul style="list-style-type: none"> • Make sure that your TV has searched for CEC devices. • If you are trying to control the volume on an HDMI® CEC audio receiver using your TV remote control, make sure that your TV speakers are turned on.

		<ul style="list-style-type: none"> • If you are trying to control the volume on an HDMI® CEC audio receiver using your TV remote control, make sure that the system audio control is turned on.
The device does not show up in the CEC device list	Connected device may not be a CEC device	<ul style="list-style-type: none"> • Make sure that the device is a CEC device. See the documentation that came with the device.
	Cables may not be connected correctly	<ul style="list-style-type: none"> • Make sure that the HDMI® cable is connected securely to your TV and the device. • Make sure that the device is connected to your TV with an HDMI® cable.
	CEC control may not be set up correctly	<ul style="list-style-type: none"> • Make sure that your TV has searched for CEC devices.
My device does not turn off when I turn off my TV	Connected device may not be a CEC device	<ul style="list-style-type: none"> • Make sure that the device is a CEC device. See the documentation that came with the device.
	Connected device may not support some or all CEC features	<ul style="list-style-type: none"> • The device may not support this feature. See the documentation that came with the device for more information.
	CEC control may not be set up correctly	<ul style="list-style-type: none"> • Make sure that your TV has searched for CEC devices. • Make sure that system standby is turned on.
My TV does not turn on when I turn on my device	Connected device may not be a CEC device	<ul style="list-style-type: none"> • Make sure that the device is a CEC device. See the documentation that came with the device.

Connected device may not support some or all CEC features	<ul style="list-style-type: none">• The device may not support this feature. See the documentation that came with the device for more information.
CEC control may not be set up correctly	<ul style="list-style-type: none">• Make sure that your TV has searched for CEC devices.• Make sure that 1-touch play is turned on.

Warning

This content is compiled from multiple sources and is provided for reference purposes only. It may not be complete or fully applicable to all situations. If you are unable to resolve your issue, please contact the product manufacturer or an authorized service provider for official support.