

## Frigidaire All about the Use & Care of your Dehumidifier

### Location

#### Location

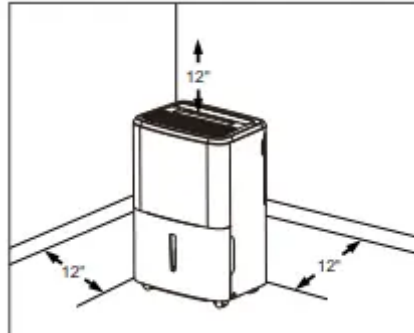

#### Selecting a Location

##### IMPORTANT:

1. Dehumidifier must be operated in an enclosed area to be most effective. Close all doors, windows, and other outside openings to the room. The effectiveness of the dehumidifier depends on the rate at which new moisture-laden air enters the room
2. Place dehumidifier in a location that does not restrict the airflow of the air intake and air outlet.
3. A dehumidifier operating in a basement will have little or no effect in drying an adjacent enclosed storage area, such as a closet, unless there is adequate circulation of air in and out of the area. It may be necessary to install a second dehumidifier in the enclosed area for satisfactory drying.
4. The dehumidifier must be installed on a level floor that will support it with a full bucket of water.
5. There should be a minimum of 12 inches clearance around the dehumidifier. The unit will produce heat while in operation and should not be operated in an enclosed small space like a closet.

### How It Works

- When the unit is started, the fan begins to pull moisture-laden air across the dehumidifying coils. The coils condense or draw moisture from the air, and air flows through the air outlet louvers into the room as dry, warm air. Moisture removed from air is collected in a bucket on the front of the dehumidifier

- The unit is designed to operate between 41 °F (5 °C), and 89 °F (32 °C). The unit will not work properly if the temperature is out of this temperature range, or the performance of the unit will fall greatly.
- The "Compressor" circuit has an automatic 3 minute time delayed start if the unit is turned off and on quickly. This prevents overheating of the compressor and possible circuit breaker tripping. Make sure the tank is fitted correctly otherwise unit will not turn on.

## Wiring Diagram

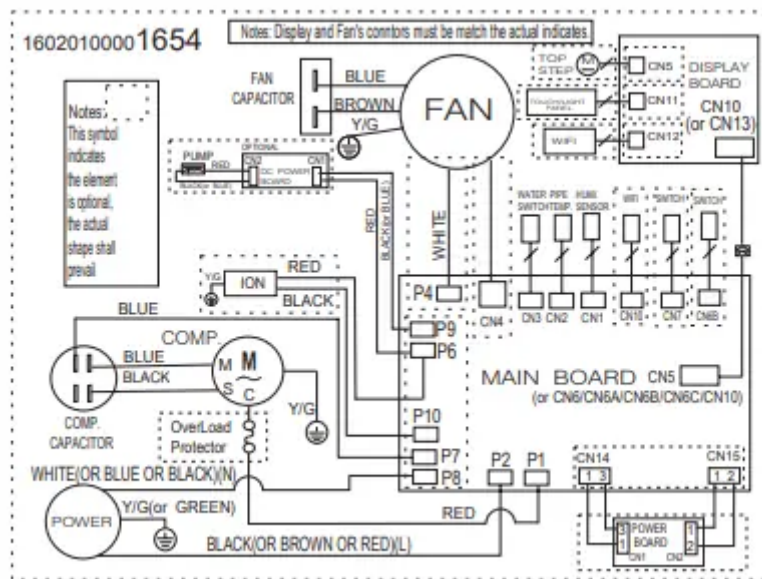

## Dehumidifier Features

**ELECTRONIC CONTROL:** Before you begin, thoroughly familiarize yourself with the control panel and all its functions (as shown below).

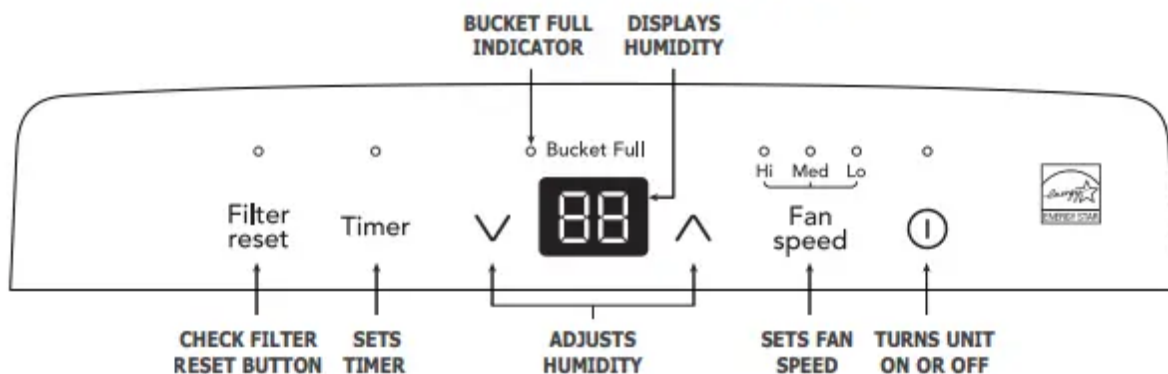

## Operating Instructions

- Allow the unit to reach room temperature before operating.
- To begin operating the dehumidifier, follow these steps:
- NOTE: Unit must be upright for one hour prior to operating

1. Plug the power cord into a properly grounded 115 volt AC outlet

NOTE: If the "BUCKET FULL" light is on, remove the bucket and re-install to reset the float switch.

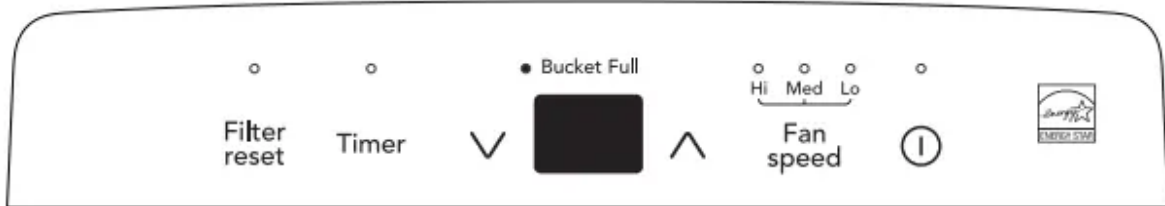

2. To turn the unit on, press the ON/OFF button. The unit will run in the factory setting of CONTINUOUS and high fan speed. In the CONTINUOUS mode, the unit will only display CO and not the room humidity. It is recommended you leave the unit running in the CONTINUOUS setting for the first three or four days until the sweating and dampness odors have stopped.

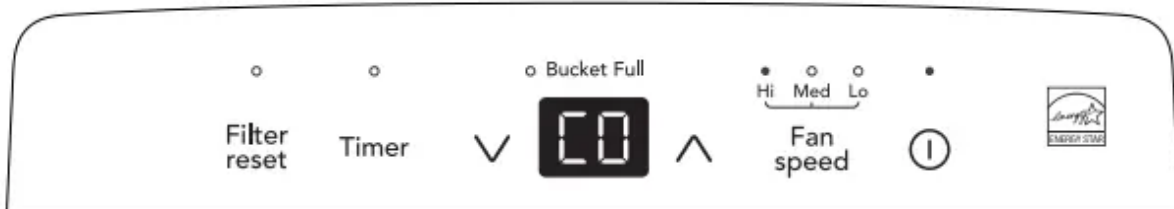

3. After a few days when the Relative Humidity has declined, press the HUMIDITY or buttons to choose a value between 35% to 85%, so the room is kept at a comfortable humidity. Pressing the or buttons will change the humidity selection in 5% increments. 5 seconds after you have set the desired humidity, the readout will display the actual room humidity. If at any time you want to return to the CONTINUOUS Mode, pressing the HUMIDITY button will lower the Relative Humidity through 5% decrements until the display reads CO.

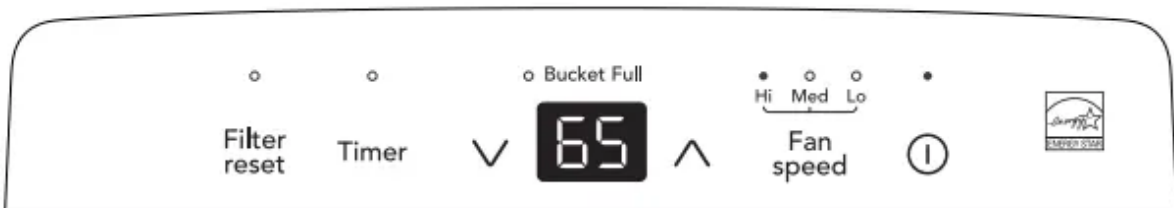

4. You can also use the FAN SPEED button to change the fan speed to Hi, Med or Lo. The indicator light will show the setting you have selected. A higher fan speed will result in quicker moisture removal.

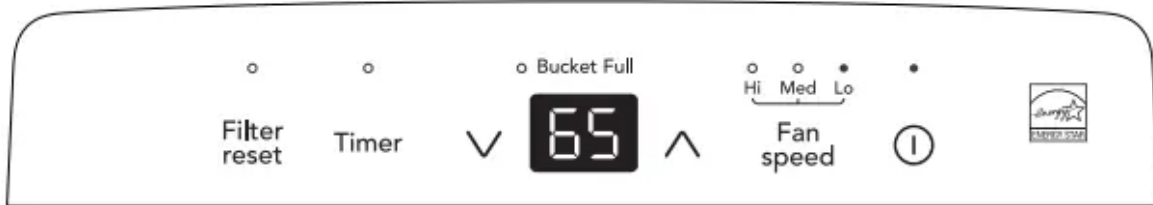

5. The Filter reset light will illuminate after 250 hours of operation. At this time refer to the care and cleaning section to remove and clean the filter. Once the filter has been cleaned and replaced, simply press the Filter reset button to extinguish the light.

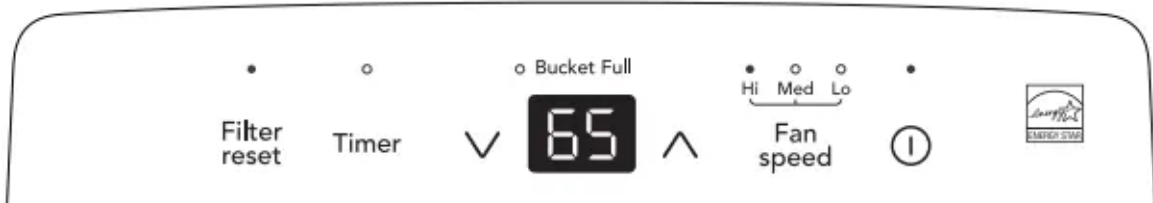

6. The TIMER function enables you to either Delay Start or Delay Stop the unit in the choice from 0.5 hour to 24 hours. If the unit is running, then selecting Timer will turn the unit off in the hours that will be set (Delay Stop). If the unit is off, then selecting Timer will turn the unit on in the hours that will be set (Delay Start). TIMER setting: First press TIMER button, then adjust timer setting, by tapping or holding the or button to change the delay timer at 0.5 hour increments, up to 10 hours, then by 1 hour increments up to 24 hours. The control will count down the time remaining (8,7.5,7, etc.) until the unit either starts or stops. For the Delay Start, the fan speed and humidity maintained will be the same as previous setting. After TIMER setting finishes, pressing TIMER button again at any time will stop the TIMER function. The Delay Start/Stop Feature will work until the unit either starts or stops. Once that happens the above steps have to be repeated.



- Before entering TIMER setting, make sure power is being supplied to the unit.
- Before entering TIMER setting, make sure pressing HUMIDITY or button sets one desired room humidity first.

7. To shut the unit down, press the ON/OFF button.

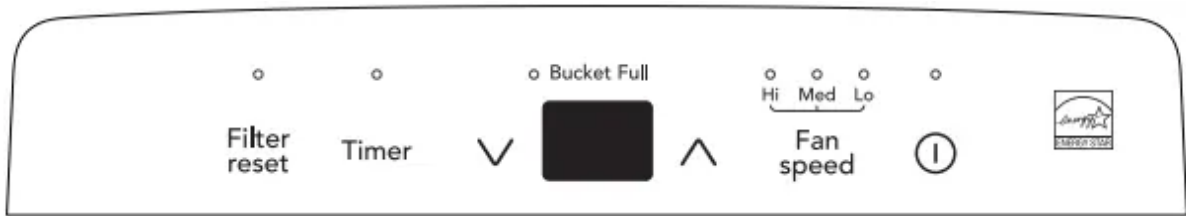

Note: After a power outage, the unit will memorize the last setting and return the unit to the same setting once power is restored.

## Fault Codes

1. If the display reads "AS" or "ES" , a sensor has failed. Contact your Authorized Frigidaire Service Center.

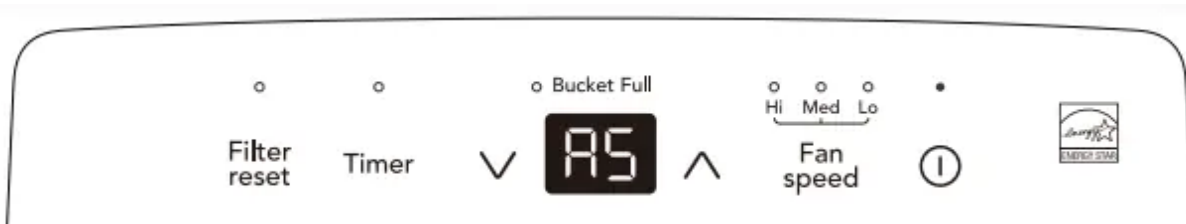

2. If the display reads "EC" , check the following operating conditions. Outlet voltage should be  $115V \pm 10\%$  and the surrounding temperature should be within the range of 41 °F to 89 °F. Unplug the unit and plug it in again under normal operating conditions. If the "EC" code persists, contact your Authorized Frigidaire Service Center.

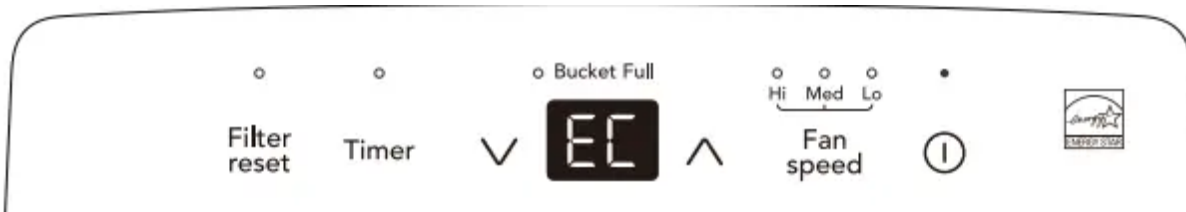

3. If the display reads "E4", the communication between display PCB and main control PCB is faulty. Contact your Authorized Electrolux Service Center.



## Removing Collected Water

1. Emptying the Bucket:
  - When the bucket is full, the unit will shut down and the BUCKET FULL indicator will illuminate



- Do not move the unit at this time otherwise water may spill on the floor.
- Press sides of bucket gently to unclip the bucket from the unit.
- Remove the bucket as shown in the photographs below and empty the bucket.

**WARNING:** Discard water from bucket. Water is not potable and cannot be used for drinking.

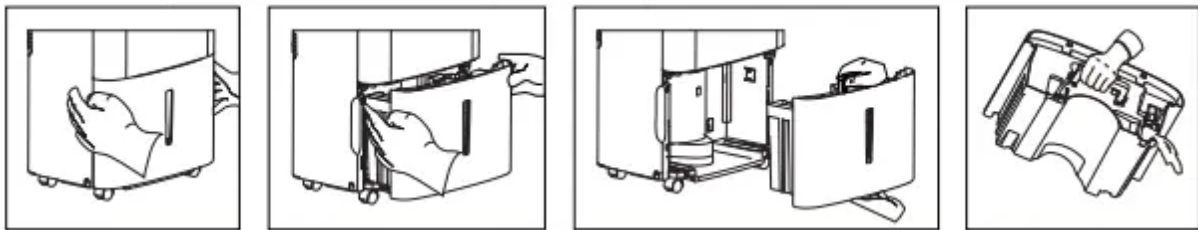

- Replace the empty bucket back into the unit and once seated correctly, the unit will start up again.
- You should hear a click when the bucket is in the correct position

If the bucket full light does not extinguish, check that the float is correctly snapped in place.

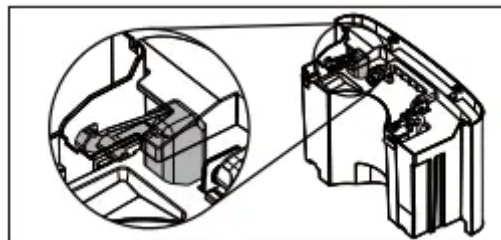

## 2. Continuous Drainage:

- For continuous drainage operation, you will need a garden hose and a drain nearby to discharge the water into.
- Unscrew the drain cap on the back side of the unit. (fig.1)
- Insert the female threaded end of the hose onto the drain connector of the unit. (fig.2)
- Screw the garden hose onto the threaded portion of the drain connector. (fig.3)
- Make sure the hose is secure so there are no leaks.
- Direct the hose toward the drain, making sure that there are no kinks that will stop the water flowing.
- Place the end of the hose into the drain. (fig.4)
- Select the desired humidity setting and fan speed on the unit for continuous draining to start.

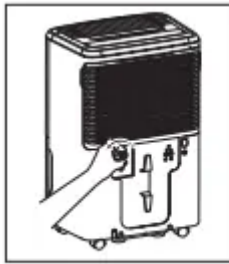

fig. 1

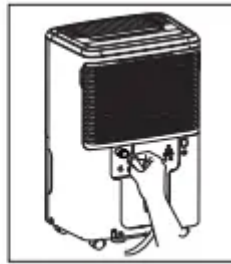

fig. 2

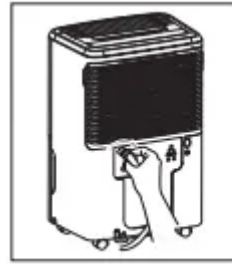

fig. 3

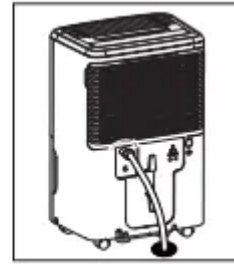

fig. 4

**NOTE:**

1. Check the seal between the hose and the drain connector. If there is a small leak then replace the hose gasket and re-tighten the hose.
2. It is recommended that a Dehumidifier Drain Hose - 1/2" (12.7 mm) or larger be used. Make sure there are no kinks or elevations in the hose.
3. When a hose is not attached to the drain connector, please ensure drain cap is screwed securely to the connector to prevent leakages

## Care and Cleaning & Storage

### Care and Cleaning

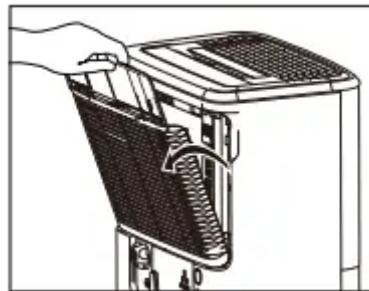

1. Filter Clean the filter every two weeks based on normal operating conditions. To remove the filter :

1. open the back grille and pull out the filter.
2. Wash the filter with clean water then dry.
3. Re-install the filter.

2. Cabinet

- Dust cabinet with an oil-free cloth, or using a damp cloth.
- Vacuum grill using brush attachment.

3. Water Bucket

- Clean bucket with warm water and detergent.

## Storage

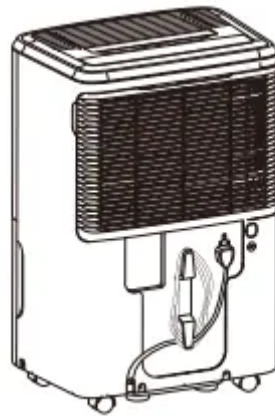

- When unit is not in use, unplug and use the cord wrap shown for your model type.

## Normal Sounds

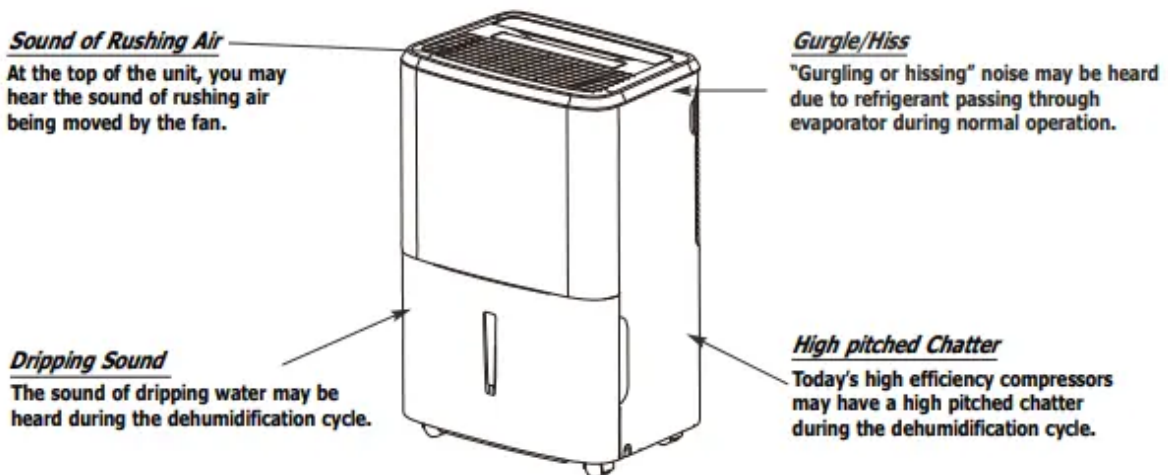

## Troubleshooting

Before You Call: Before calling for service, review this list. It may save you time and expense. This list includes common occurrences that are not the result of defective workmanship or materials in this appliance.

### OCCURRENCE -- SOLUTION

#### 1. DEHUMIDIFIER DOES NOT OPERATE.

- Wall plug disconnected. Push plug firmly into wall outlet.
- House fuse blown or circuit breaker tripped. Replace fuse with time delay type or reset circuit breaker.
- The dryness level you selected has been reached. Dehumidifier automatically shuts off when selected amount of moisture has been removed from the air. If you want to remove

more moisture, Select 'CONTINUOUS' by using the humidity button or knob. After the dehumidifier starts, reset the control to the desired setting.

- Bucket not installed properly. See “Removing Collected Water”.
- Water in the bucket has reached its preset level. Dehumidifier automatically turns off when this occurs. Empty bucket and return bucket to position.
- Dehumidifier is not turned on. Turn unit on.
- “BUCKET FULL” light is on. Remove bucket, empty water and re-install correctly.

## 2. DEHUMIDIFIER RUNS TOO MUCH.

- Windows or doors near dehumidifier are open to outdoors. Close all windows or doors to outside.
- Area to be dehumidified is too large. Check with your dealer to see if capacity is adequate.
- Air movement through dehumidifier is blocked. Grill may be dirty. Use brush attachment of vacuum cleaner to clean grill. See “Care and Cleaning”. Dehumidifier must be placed in a space that does not restrict air flowing into the rear coil or out of the front grill
- Dehumidifier has been installed or restarted recently. The higher the moisture in the room, the longer the dehumidifier will operate.
- Dehumidifier is in the CONTINUOUS mode and will remain on in this mode, use the humidity button or knob to set a RH% higher level.

## 3. DEHUMIDIFIER IS OPERATING BUT ROOM IS NOT DRY ENOUGH.

- Windows or doors near dehumidifier are open to outdoors. Close all windows or doors to outside.
- Area to be dehumidified is too large. Check with your dealer to see if capacity is adequate.
- Air movement through dehumidifier is blocked. Grill may be dirty. Use brush attachment of vacuum cleaner to clean grill. See “Care and Cleaning”. Dehumidifier must be placed in a space that does not restrict air flowing into the rear coil or out of the front grill.
- Dehumidifier has been installed or restarted recently. The higher the moisture in the room, the longer the dehumidifier will operate.
- Dehumidifier is in the CONTINUOUS mode and will remain on in this mode, use the humidity button or knob to set a RH% higher level.

## 4. DEHUMIDIFIER IS OPERATING BUT ROOM IS NOT DRY ENOUGH.

- Humidity setting is too high. Press the HUMIDITY button or rotate knob to a lower setting or choose CONTINUOUS for maximum dryness.
- Dehumidifier has been installed or restarted recently. The higher the moisture in the room air, the longer it takes for the room air to become dry

- Dehumidifier does not have sufficient clearance to operate. Air flow to the air outlet is blocked. See “Selecting a Location”.
- Room temperature is too low. Unit will not operate satisfactorily if the room temperature is below 41 °F(5 °C). See “Operating Conditions”.
- Refer to causes under DEHUMIDIFIER RUNS TOO MUCH.

#### 5. FROST APPEARS ON COILS BEHIND THE FILTER

- Dehumidifier has been turned on recently. This is normal due to refrigerant rushing through the coil. Frost will usually disappear within 60 minutes.
- Room Temperature is too low. All models will operate satisfactorily at temperatures greater than 41 °F (5 °C).

#### 6. FAN NOISE.

- Air is moving through the dehumidifier. This is a normal sound.

#### **Warning**

This content is compiled from multiple sources and is provided for reference purposes only. It may not be complete or fully applicable to all situations. If you are unable to resolve your issue, please contact the product manufacturer or an authorized service provider for official support.