

Microwave Solo Oven Instruction



MATERIALS YOU CAN USE IN MICROWAVE OVEN

UTENSILS	REMARKS
Aluminum foil	Shielding only. Small smooth pieces can be used to cover thin parts of meat or poultry to prevent overcooking. Arcing can occur if foil is too close to oven walls. The foil should be at least 1 inch (2.5cm) away from oven walls.
Browning dish	Follow manufacturer's instructions. The bottom of browning dish must be at least 3/16 inch (5mm) above the turntable. Incorrect usage may cause the turntable to break.
Dinnerware	Microwave-safe only. Follow manufacturer's instructions. Do not use cracked or chipped dishes.
Glass jars	Always remove lid. Use only to heat food until just warm. Most glass jars are not heat resistant and may break.
Glassware	Heat-resistant oven glassware only. Make sure there is no metallic trim. Do not use cracked or chipped dishes.
Oven cooking bags	Follow manufacturer's instructions. Do not close with metal tie. Make slits to allow steam to escape.
Paper plates and cups	Use for short-term cooking/warming only. Do not leave oven unattended while cooking.
Paper towels	Use to cover food for reheating and absorbing fat. Use with supervision for a short-term cooking only.
Parchment paper	Use as a cover to prevent splattering or a wrap for steaming.
Plastic	Microwave-safe only. Follow the manufacturer's instructions. Should be labeled "Microwave Safe". Some plastic containers soften, as the food inside gets hot. "Boiling bags" and tightly closed plastic bags should be slit, pierced or vented as directed by package.
Plastic wrap	Microwave-safe only. Use to cover food during cooking to retain moisture. Do not allow plastic wrap to touch food.
Thermometers	Microwave-safe only (meat and candy thermometers).
Wax paper	Use as a cover to prevent splattering and retain moisture.

MATERIALS TO BE AVOIDED IN MICROWAVE OVEN

UTENSILS	REMARKS
Aluminum tray	May cause arcing. Transfer food into microwave-safe dish.
Food carton with metal handle	May cause arcing. Transfer food into microwave-safe dish.
Metal twist ties	May cause arcing and could cause a fire in the oven.
Paper bags	May cause a fire in the oven.
Plastic foam	Plastic foam may melt or contaminate the liquid inside when exposed to high temperature.
Wood	Wood will dry out when used in the microwave oven and may split or crack.

SETTINGUP YOUR OVEN

NAMES OF OVEN PARTS AND ACCESSORIES

Remove the oven and all materials from the carton and oven cavity. Your oven comes with the following accessories:

Glass Tray	1
Turntable ring	1
Instruction Manual	1

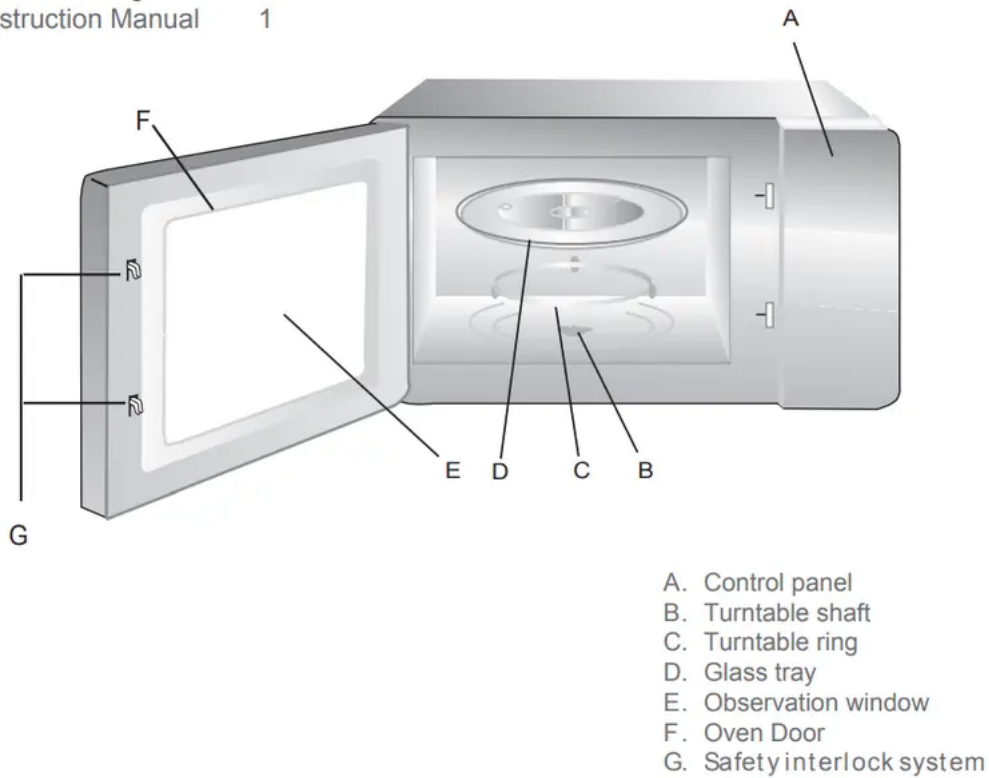

TURNTABLE INSTALLATION

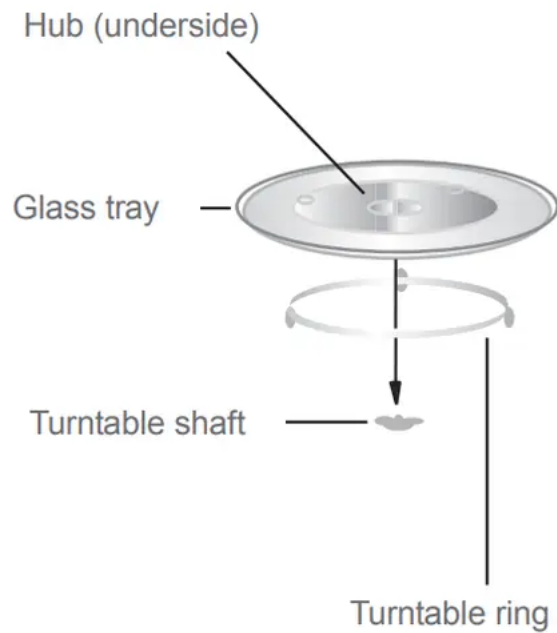

- a. Never place the glass tray upside down. The glass tray should never be restricted.
- b. Both glass tray and turntable ring must always be used during cooking.
- c. All food and containers of food are always placed on the glass tray for cooking.

COUNTERTOP INSTALLATION

Remove all packing material and accessories. Examine the oven for any damage such as dents or broken door. Do not install if oven is damaged.

Cabinet: Remove any protective film found on the microwave oven cabinet surface. Do not remove the light brown Mica cover that is attached to the oven cavity to protect the magnetron.

INSTALLATION

1. Select a level surface that provide enough open space for the intake and/or outlet vents.

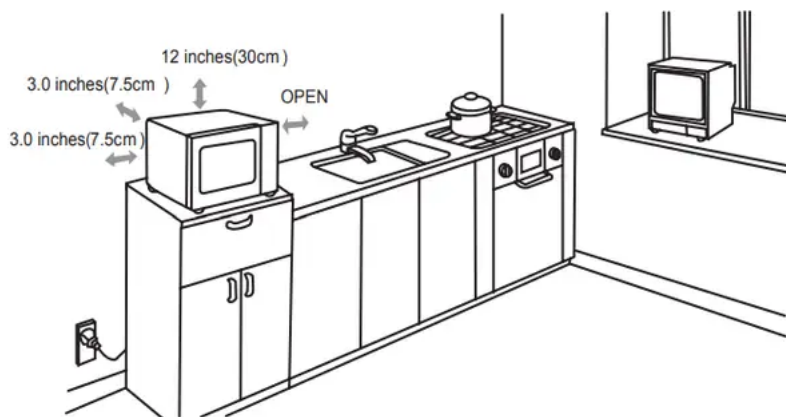

A minimum clearance of 3.0 inches (7.5cm) is required between the oven and any adjacent walls.

One side must be open.

1. Leave a minimum clearance of 12 inches (30cm) above the oven.
2. Do not remove the legs from the bottom of the oven.
3. Blocking the intake and/or outlet openings can damage the oven.
4. Place the oven as far away from radios and TV as possible.

Operation of microwave oven may cause interference to your radio or TV reception.

2. Plug your oven into a standard household outlet. Be sure the voltage and the frequency is the same as the voltage and the frequency on the rating label.

WARNING

Do not install oven over a range cooktop or other heat-producing appliance. If installed near or over a heat source, the oven could be damaged and the warranty would be void.



The accessible surface may
be hot during operation

OPERATION

CONTROL PANEL AND FEATURES

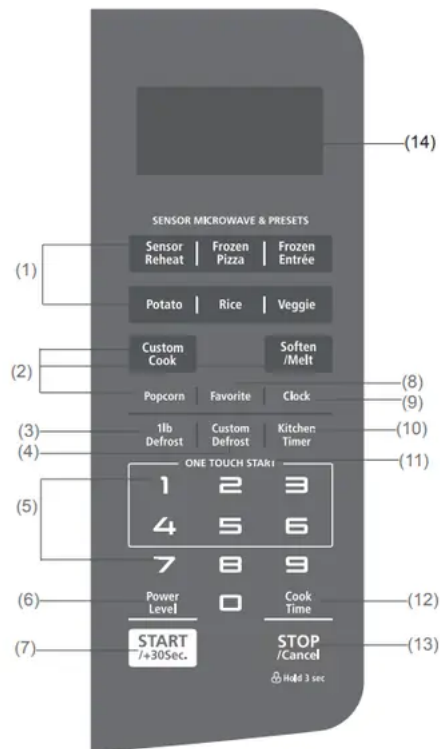

- (1) Quick Touch Presets--- Sensor Menu (Sensor Reheat, Frozen Pizza, Frozen Entree, Potato, Rice, Veggie)
- (2) Auto Menu (Custom Cook, Soften/Melt), Popcorn
- (3) Automatically defrosts one pound items
- (4) Custom Defrost: Defrost time calculated by entered weight and category of item
- (5) Number Pads
- (6) Power Level
- (7) START ADD 30 SEC
- (8) Favorite
- (9) Clock
- (10) Kitchen Timer
- (11) ONE TOUCH START Pads (1- 6)
- (12) Cook time
- (13) STOP Cancel Hold 3 sec: Before cooking starts, press to clear all previous settings. During cooking, press once to stop oven; press twice to stop oven and clear all settings.
- (14) Display Window

1.POWER LEVELS

Ten power levels are available.

Prior to or during cooking, press Power Level and "PL10" will display. Then press number pads to select a different power level.

Level	10	9	8	7	6	5	4	3	2	1
Power	100%	90%	80%	70%	60%	50%	40%	30%	20%	10%
Display	PL10	PL 9	PL 8	PL 7	PL 6	PL 5	PL 4	PL 3	PL 2	PL 1

2.CLOCK SETTING

When the microwave oven is plugged into an outlet, "0:00" will display.

1. Press Clock once, "00:00" will appear in the display.
2. Press the number pads to enter the current clock time. For example, if the time is now 10:12, press " 1, 0, 1, 2 " in order.
3. Press Clock to finish clock setting, " : " will flash and the numbers will appear as a clock time in the display.



NOTE:

- If the numbers entered are not within the range between 1:00 to 12:59, the setting will not be accepted until valid numbers are entered.
- In the process of setting clock, if the  pad is pressed or if there is no operation within 1 minute, the display will automatically return to the previous clock setting.

3. KITCHEN TIMER

1. Press Kitchen Timer once, "00:00" will appear in the display.
2. Press the number pads to enter the time amount. The maximum amount of time that can be entered is 99 minutes, 99 seconds
3. Press  to confirm setting, and the timer will start to count down.
4. When the time amount elapses, timer indicator will disappear. The oven will beep 5 times

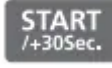
Note:

- The Kitchen Timer setting is different from the Clock setting; it is simply a timer.
- During the Kitchen Timer function, no cooking function can be set into operation.
- Kitchen Timer amount cannot be increased by pressing .
- Pressing  will cancel the Timer countdown.

4. MICROWAVE COOK

1. Press Cook Time , "00:00" will appear in the display.
2. Press number pads to enter the cooking time. The maximum cooking time is 99 minutes, 99 seconds.
3. Press Power Level, PL10 will flash. Press number pads 0 through 9 to select a different power level if desired. See the POWER LEVEL table above.
4. Press  to start cooking. The remaining cooking time will display.

Example : To cook the food with 50% microwave power for 15 minutes.

- a. Press Cook Time , "00:00" will display.
- b. Press "1, 5, 0, 0" in order for 15:00 to appear in the display.
- c. Press Power Level , then press "5" to select 50% microwave power.
- d. Press  to start cooking. Buzzer sounds once. The remaining cooking time will display.



NOTE:

In the process of setting, if the  pad is pressed or if there is no operation within 1 minute, the oven will automatically return to display the clock.

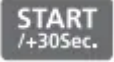
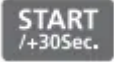
5. ONE TOUCH START

1. Instant cooking at 100% power level and 1 to 6 minutes cooking time can be started by pressing number pads 1 to 6. Press  to increase the cooking time by 30 seconds with each press. The maximum cooking time is 99 minutes, 99 seconds.
2. Instant cooking at 100% power level and 30 seconds cooking time can be started by pressing  . Each repeated press will increase cooking time by 30 seconds. The maximum cooking time is 99 minutes, 99 seconds.

NOTE:

- Time can also be added in 30 second increments by pressing  during Microwave Cooking, Time Defrost and Multi-stage Cooking.
- Time cannot be added by pressing  during Weight Defrost and Kitchen Timer functions.

6.CUSTOM DEFROST FUNCTION

1. Press **Custom Defrost** , "dEF1" and "DEF." will appear in the display.

Press the same pad repeatedly, "dEF2", "dEF3", "dEF1" will display in order.

LED display	dEF1	dEF2	dEF3
Food	Meat	Poultry	Fish

2. Press number pads to enter the weight to be defrosted.
Input the weight range between 0.1 to 6.0 Lbs.If the weight input is not between 0.1 to 6.0 Lbs, the input will be invalid. The unit will not work until valid numbers are entered.

3. Press  to start defrosting and the cooking time remaining will be displayed ."DEF." indicator will flash.

Note:When half of the defrosting time passes, the oven will beep once to remind you to turn over

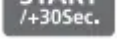
the food. Open the door to pause operation. Turn over food, close door and press  to resume defrost cycle. If you do not open door to pause to resume defrost cycle. If you do not open door to pause

7.1 LB DEFROST

- (1) Press **1lb Defrost**, "1.0", "DEF." and "Lbs" will appear in the display.

- (2) Press  to start defrosting, "Lbs" will disappear. "DEF." will flash, and the remaining defrost time will display.

8.SENSOR MENU

(Sensor Reheat, Frozen Pizza, Frozen Ent é r e, Potato,Rice,Veggie)

- 1) Press the pad for one of the Sensor Menu functions. An "SC-" number, "Auto" and "SENS." will appear in the display. Example: If "Rice" is pressed, "SC-5" will display.

- 2) Press  to start the sensor cooking process. Once the item has been sensed the remaining cooking time will display. The oven beeps 5 times when cooking is finished.

Note

1. For best sensor cooking results:
 1. The room temperature cannot be over 95 F (35 C).
 2. The weight of food must be more than 4 Oz (110 g).
 3. The oven cavity, glass tray and utensils must be dry.

2. During cooking:

1. The food can be covered, but the cover or lid must be vented with a hole to allow steam to escape.
2. Wait until the cooking time is displayed and starts to count down. Opening the door or press  before the cooking time is displayed will cause an error in the sensor cooking process.
3. Once the cooking time displays and starts counting down, you can open the door to mix or turn over food.

Example: Potato Sensor Pad

1) Press **Potato** pad once, "SC-4", "Auto" and "SENS." will appear in the display.

2) Press  to cook.

Note:

- a. Puncture the surface of each potato several times with the times of a fork.
- b. Place up to 4 potatoes on the glass turntable. Keep at least 1 inch of space between each potato.

Example: Sensor Reheat Pad

1) After placing food into oven, press **Sensor Reheat** pad and "SC-1" will display.

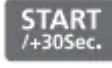
2) Press  to cook. Oven beeps 5 times when cooking is finished.

Note:

1. Food to be avoided in sensor reheating.
 1. Bread and other dry food, such as biscuits or cake.
 2. Raw or uncooked food.
 3. Beverages and frozen food.
2. The food can be covered, but the cover or lid must be vented with a hole to allow steam to escape.
3. The food temperature must be at least 40 F (5 C) when placing it into the oven for Sensor Heat to work correctly.
4. Preparing foods for Sensor Reheat.

Casseroles - Add 2 to 3 tablespoons of liquid, covered with lid or vented plastic wrap. Stir when time appears in the display window.

Canned foods - Empty contents into casserole dish or serving bowl, and cover with vented lid or plastic wrap. After reheating, let food stand for a few minutes.

Plate of food - Arrange food on plate; top with butter, gravy, etc. Cover with vented lid or plastic wrap. After reheating, let food stand for a few minutes.

Example Veggie

1. Press Veggie once, "SC-6" will display, to cook fresh vegetable.
Press Veggie 2 times, "SC-7" will display, to cook frozen vegetable.
2. Press  to cook. After the cooking time displays, food can be turned over.
Oven beeps 5 times when cooking is finished.

Sensor menu chart:

Menu button	Sensor Reheat	Frozen Pizza	Frozen Entrée	Potato	Rice	Veggie
Food	Sensor Reheat	Frozen Pizza	Frozen Entrée	Potato	Rice	Fresh/Frozen Vegetable
Food Code	SC-1	SC-2	SC-3	SC-4	SC-5	SC-6/SC-7
Weight/Portion	8~32 oz	6~12 oz	8~32 oz	1~4 potatoes 10 oz each	8.0 oz~1 6.0 oz	4~16 oz

9.POPCORN

a) Press Popcorn repeatedly until the number you wish appears in the display. "4.75". "3.0". "3.5" oz will display in order. And "Auto" and "Oz" will appear in the display.

b) Press  to cook. "Oz" disappears." Auto "flashes.
Oven beeps 5 times when cooking is finished.

10.CUSTOM COOK

- a) Press **Custom Cook**. "CC-1" and "Auto" will appear in the display.
- b) Press **Custom Cook** more times. "CC-2. CC-3. CC-4. CC-5" will display in order.
- c) After selecting CC setting, press a number pad to select the weight or portion of food item.

d) Press  to cook. "Auto" flashes in display.
Oven beeps 5 times when cooking is finished.

11.SOFTEN/MELT

- a). Press Soften/Melt. "S-1" will display.
- b) Press Soften/Melt more times. "S-2. S-3. S-4. S-5. S-6. S-7" will display in order.



c) After selecting SC function. press a number pad to select the weight or portion of food item

d) Press  to cook. Auto" flashes in display.

Oven beeps 5 times when cooking is finished.

12.FAVORITE FUNCTION

(1) Press Favorite to program and choose up to three cooking procedures.

Each procedure will be indicated by 1, 2 or 3 in the display.

(2) Press Favorite until your desired procedure number appears in the display.

Press  to begin it. A maximum of two cooking stages can be set for each procedure.

(3) To program a procedure. follow the steps listed below. Example: Cook food at 80% Power Level for 3 minutes and 20 seconds; save as memory 2.

a. Press **Favorites** twice; screen displays 2.

b. Press **Cook Time** once, then press "3", "2" and "0" in order.

c. Press **Power Level** once, then press "8" for "PL8" to display.

d.

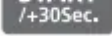
Press **Favorite** to save the procedure. Oven beeps once. Or press  directly to start cooking.

e. To choose the procedure from the memory list, press **Favorite** twice. Screen will display

"2". Press  to run procedure.

Note: The procedure will remain programmed until the oven is unplugged or there is a power failure. If either occurs, the procedure will have to be reprogrammed into the oven.

Auto Menu Chart:

Menu Button	Food	Display	Weight/portion
Custom Cook	Custom Cook-Bacon	CC-1	2-6 SLICES
	Custom Cook-Frozen roll/Muffin-reheat	CC-2	1-6 PIECES
	Custom Cook-Beverage	CC-3	1-2 CUPS
	Custom Cook-Chicken Pieces	CC-4	0.5-2.0 Lbs
	Custom Cook-Oatmeal(with milk)	CC-5	20/40 Oz
Soften/Melt	Melt-Butter/Margarine	S-1	1-3 STICKS
	Melt-Chocolate	S-2	4/8 Oz
	Melt-Cheese	S-3	8/16 Oz
	Melt-Marshmallows	S-4	5/10 Oz
	Soften-Butter	S-5	1-3 STICKS
	Soften-Ice cream/Frozen juice	S-6	6/12/16 Oz
	Soften-Cream cheese	S-7	3/ 8 Oz

13.MULTI-STAGE COOKING

At most 2 stages can be set for cooking. If one stage is Defrost, it will automatically

Note : Quick Touch Presets cannot be used in multi-stage cooking. set to be the first stage.

Example: 80% Power Level for 5 minutes followed by 60% Power Level for minutes; saved as memory 3.

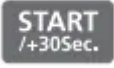
- a. Press **Favorite** 3 times; screen displays 3.
- b. Press **Cook Time** once, then press "5", "0" and "0" to set first stage cook time.
- c. Press **Power Level** once, then press "8" to choose 80% first stage cooking power.
- d. Press **Cook Time** again, then press "1", "0", "0" and "0" to set second stage cook time.
- e. Press **Power Level** again, then press "6" to choose 60% second stage cooking power.
- f. Press  to immediately start multi-stage cooking.
- g. To choose the procedure from the memory list, press **Favorite** three times. Screen will display "3"; press  to run procedure.

Note: If you do not want to save a particular multi-stage program as a procedure, do not press as the first step. Multi-stage cooking will begin the first time.

Press  after programming both stages.

14. INQUIRING FUNCTION

1. When oven is cooking, press Clock for the time of day to appear for three seconds in the display.
2. When oven is cooking, press Power Level pad for cooking power to appear for three seconds in the display.

15. LOCK FUNCTION

To lock the microwave so that it cannot be operated by children or other unintended users, press

 pad for 3 seconds. You will hear a long beep. If the clock has been set, the time of day and "Lock" will appear in the display. Otherwise, only "Lock" will appear. To Unlock, press

 for three seconds, you will hear a long beep and "Lock" will disappear.

16. COOKING END REMINDER FUNCTION

The oven will beep five times to alert the user that cooking time has ended. "End" will display. The time of day will display by opening the door or pressing  pad.

17. OTHER SPECIFICATIONS

1. When setting cooking function, the function abbreviation appears in the display.
2. When oven is cooking or paused (door opened) in the midst of cooking time, the remaining cooking time appears in the display

TROUBLESHOOTING

Check your problem by using the chart below and try the solutions for each problem

TROUBLE	Possible Cause	Possible Remedy
Oven will not start	<ul style="list-style-type: none"> a. Electrical cord for oven is not plugged in. b. Door is open. c. Wrong operation is set. 	<ul style="list-style-type: none"> a. Plug into the outlet. b. Close the door and try again. c. Check instructions
Arcing or sparking	<ul style="list-style-type: none"> a. Materials to be avoided in microwave oven were used. b. The oven is operated when empty. c. Spilled food remains in the cavity 	<ul style="list-style-type: none"> a. Use microwave-safe cookware only. b. Do not operate with oven empty. c. Clean cavity with wet towel.
Unevenly cooked foods	<ul style="list-style-type: none"> a. Materials to be avoided in microwave oven were used. b. Food is not defrosted completely. c. Cooking time, power level is not suitable. d. Food is not turned or stirred. 	<ul style="list-style-type: none"> a. Use microwave-safe cookware only. b. Completely defrost food. c. Use correct cooking time, power level. d. Turn or stir food
Overcooked foods	Cooking time, power level is not suitable.	Use correct cooking time, power level.

Undercooked foods	<ul style="list-style-type: none"> a. Materials to be avoided in microwave oven were used. b. Food is not defrosted completely. c. Oven ventilation ports are restricted. d. Cooking time, power level is not suitable. 	<ul style="list-style-type: none"> a. Use microwave-safe cookware only. b. Completely defrost food. c. Check to see that oven ventilation ports are not restricted. d. Use correct cooking time, power level
Improper defrosting	<ul style="list-style-type: none"> a. Materials to be avoided in microwave oven were used. b. Cooking time, power level is not suitable. c. Food is not turned or stirred. 	<ul style="list-style-type: none"> a. Use microwave-safe cookware only. b. Use correct cooking time, power level. c. Turn or stir food
Sensor cooked foods not properly cooked	<ul style="list-style-type: none"> a. Cover or lid on food not vented. b. Door opened before sensor-detected cooking time appears in display 	<ul style="list-style-type: none"> a. Cover or lid over food must contain vent hole for escaping steam. b. Do not open door to stir or turn food before sensor-detected cooking time appears in display

Warning

This content is compiled from multiple sources and is provided for reference purposes only. It may not be complete or fully applicable to all situations. If you are unable to resolve your issue, please contact the product manufacturer or an authorized service provider for official support.



