

## PARTS AND FEATURES

### PARTS AND ACCESSORIES

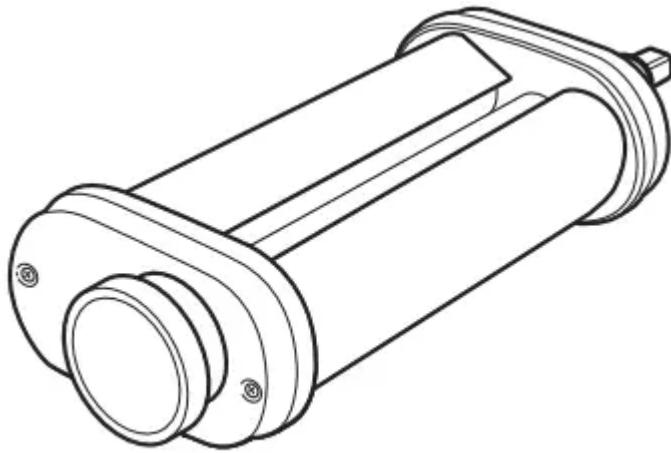

**Pasta roller**

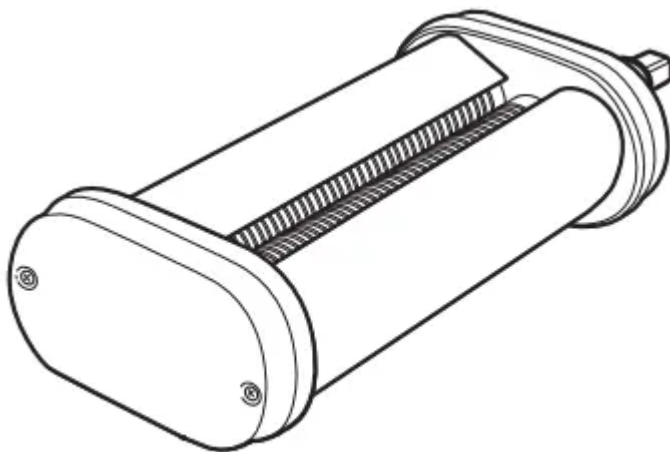

**Spaghetti cutter**

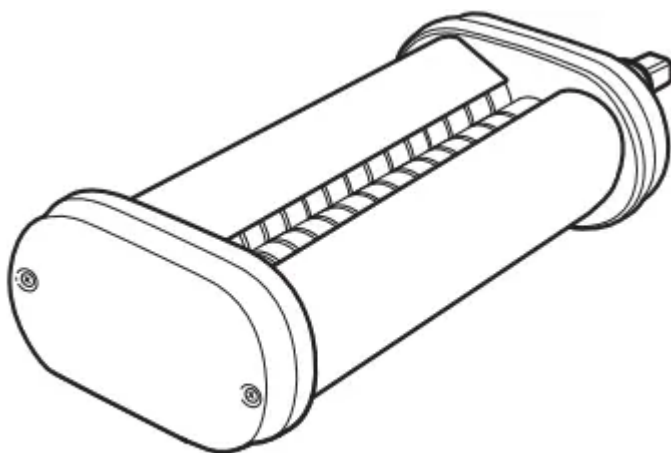

**Fettuccine cutter**

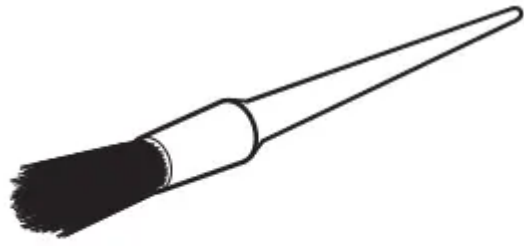

**Cleaning brush**

## USING THE PASTA ROLLER AND CUTTERS

### SPEED SETTINGS CHART

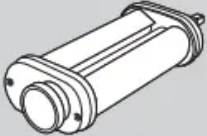
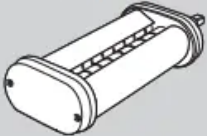
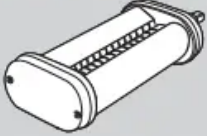
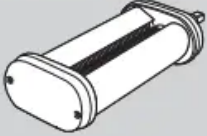
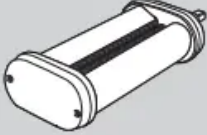
ATTACHMENT	SPEED	NOODLE WIDTH	SUGGESTED USES
PASTA ROLLER 	2	up to 140 mm	See roller settings chart
LASAGNETTE CUTTER 	3	12 mm	Thick Noodles
FETTUCCINE CUTTER 	5	6.5 mm	Egg Noodles Fettuccine
SPAGHETTI CUTTER 	7	2 mm	Spaghetti Thin Fettuccine Linguine Fini
CAPELLINI CUTTER 	7	1.5 mm	Very Thin Angel Hair-Type Pasta Capellini Very Fine Linguine

## ROLLER SETTINGS CHART

ATTACHMENT	ROLLER SETTING	SUGGESTED USES
	1 or 2	Kneading and thinning dough
	3	Thick "kluski"-type noodles
	4	Egg noodles
	4 or 5	Lasagna noodles, fettuccine, spaghetti, and ravioli
	6 or 7	Tortellini, thin fettuccine, and linguini fini
	7 or 8	Very thin "angel-hair"-type pasta/capellini or very fine linguine

## ATTACHING THE PASTA ROLLER AND CUTTERS

Before first use To avoid damage, do not wash or immerse attachments in water or other liquid. Do not wash in dishwasher.

**NOTE:** These attachments are designed to be used with pasta dough only. To avoid damaging your Pasta Roller, do not cut or roll anything other than pasta.

1. Turn Stand Mixer off and unplug.

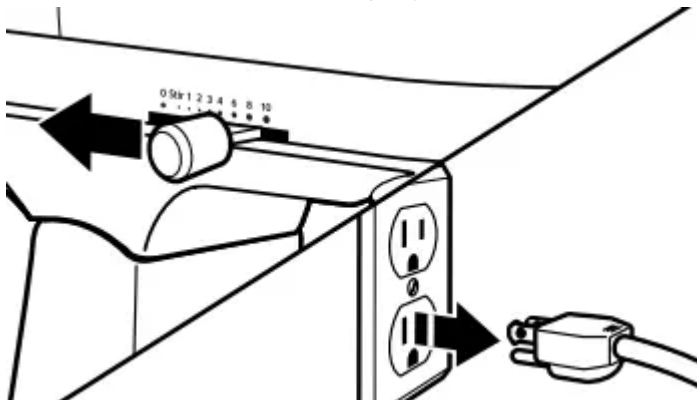

2. **For Stand Mixers with a hinged attachment hub cover:** Flip up to open.  
**For Stand Mixers with a removable attachment hub cover:** Turn the attachment knob counterclockwise to remove attachment hub cover

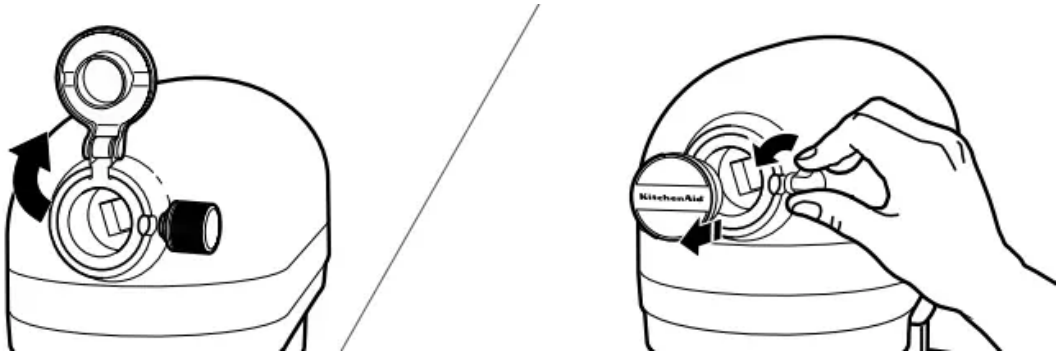

3. Insert attachment shaft housing into the attachment hub, making certain the power shaft fits into the square hub socket. If necessary, rotate the Pasta Roller or Cutter back and forth. The pin on the attachment housing fits into the notch of the hub rim when in the

proper position.

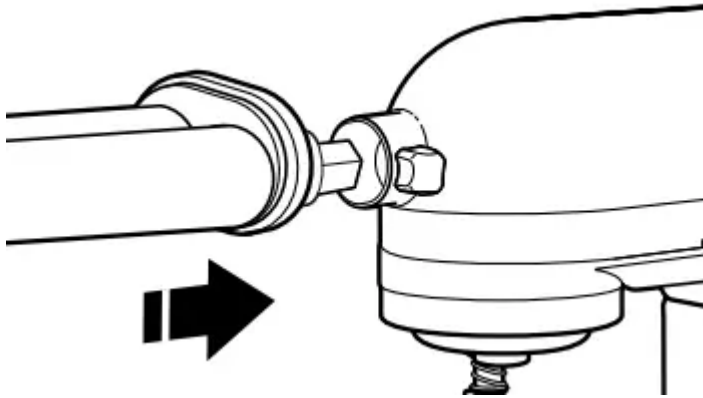

4. Tighten the Stand Mixer attachment hub knob until the attachment is completely secured to the Stand Mixer.

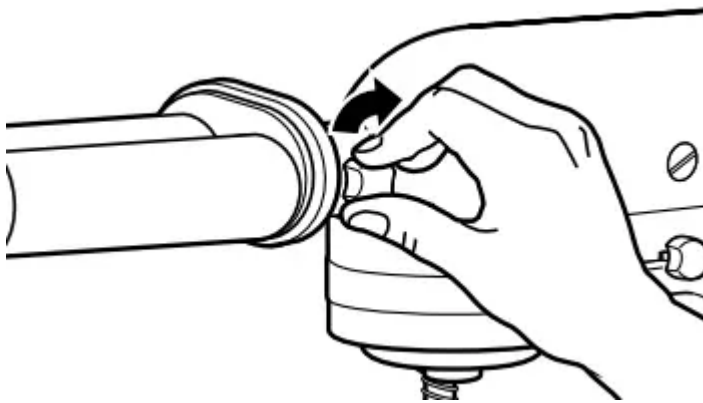

## MAKING PASTA

**IMPORTANT:** When using the Pasta Roller and Cutters, do not wear ties, scarves, loose clothing or long necklaces; gather long hair with a clasp.

1. Prepare pasta dough. Cut dough into sections that fit in the Pasta Roller.



2. Pull the Pasta roller adjustment knob straight out and turn to setting 1. Release the knob, making certain the pin on the Pasta roller housing engages the opening on the back of

the adjustment knob, allowing the knob to fit flush against the roller housing.

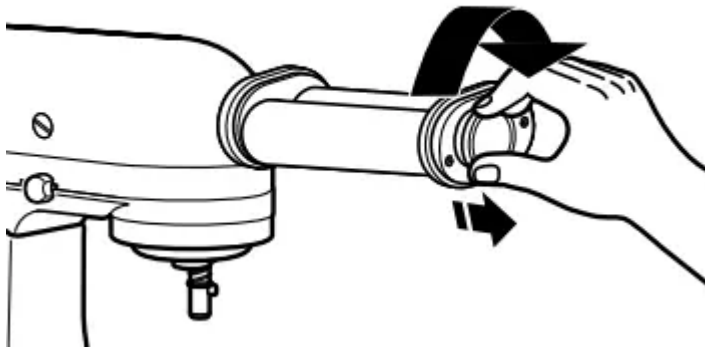

3. Turn Stand Mixer to speed 2. Feed flattened dough into rollers to knead. Fold dough in half and roll again. Repeat until dough is smooth and pliable and covers the width of the roller. Lightly dust pasta with flour while rolling and cutting to aid in drying and separation.

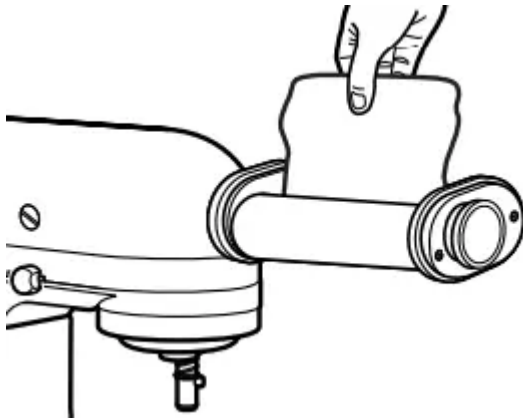

4. Feed dough through rollers to further flatten the sheet of dough. Change the roller to setting 3, and repeat the rolling process. Continue to increase roller setting until desired thickness is reached. Do not fold the dough during this step.

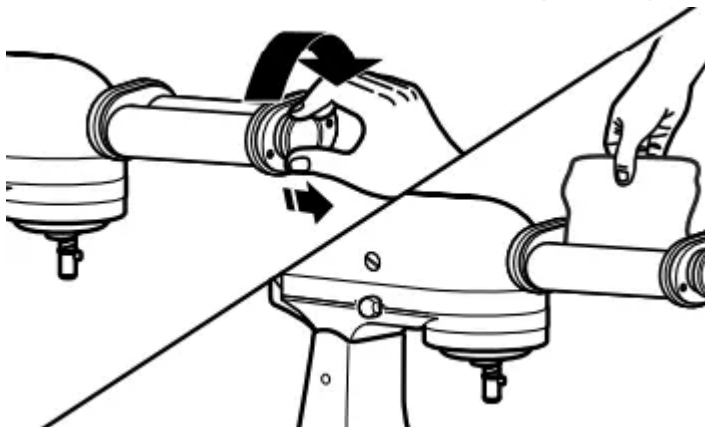

5. To make noodles, exchange the Pasta Roller for the Cutter of your choice. Feed the flattened sheets of dough through the cutter. See the “Roller settings chart” to determine

the correct thickness for each type of pasta.

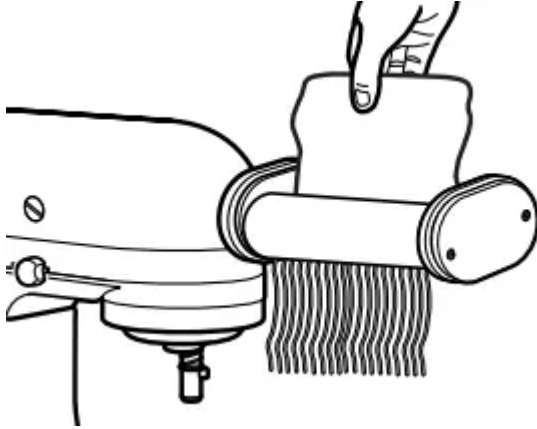

## DISASSEMBLING THE PASTA ROLLER AND CUTTERS

1. Turn Stand Mixer off and unplug.

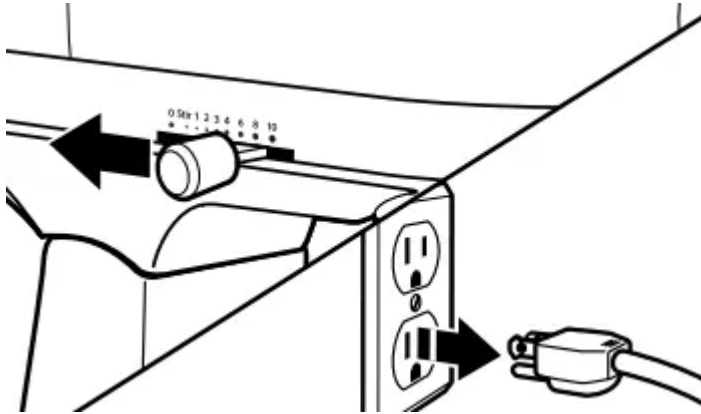

2. Remove the Pasta Roller or Cutter from the Stand Mixer.

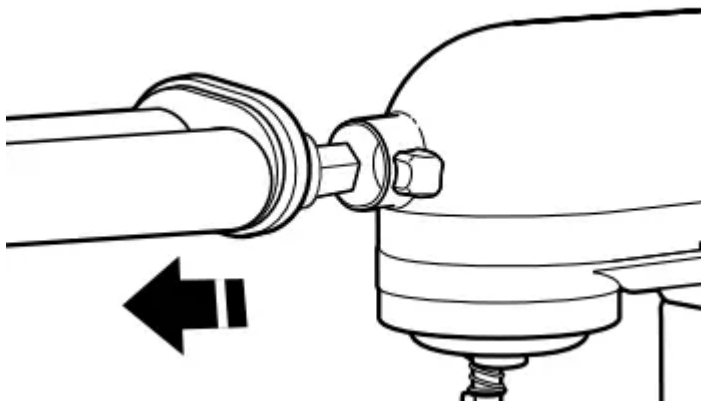

**IMPORTANT:** After removing the Pasta Roller or Cutter from the Stand Mixer, be sure to clean any dried dough. See “Care and Cleaning” for details.

**OPTIONAL:** If desired, attach the next Pasta Roller or Cutter, using the directions in the “Attaching the Pasta Roller and Cutters” section.

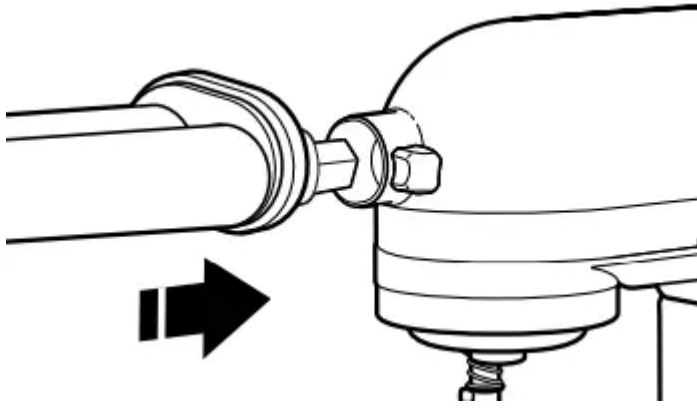

**NOTE:** Allow Stand Mixer to rest for at least 1 hour after extruding 2 consecutive pasta dough recipes.

3. After finishing with the Pasta Roller and Cutters replace the hub cover and tighten the attachment knob on the Stand Mixer.

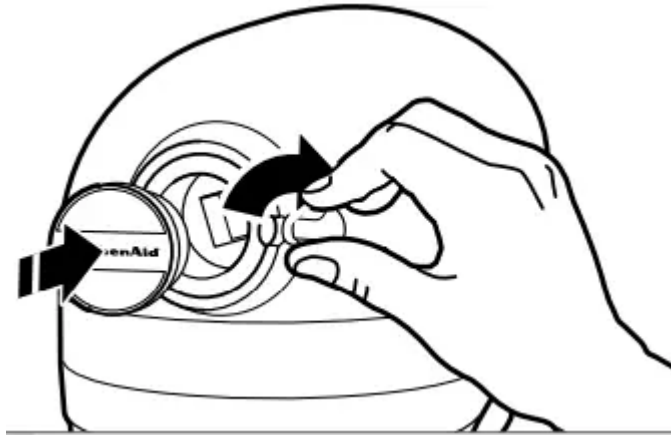

## CARE AND CLEANING

### CLEANING THE PASTA ROLLER AND CUTTERS

These accessories are designed to be used with pasta dough only. To avoid damaging your Pasta Roller and Cutters, do not insert anything other than pasta dough.

**IMPORTANT:** Do not use metal objects to clean out the Pasta Roller and Cutters. Do not wash the Pasta Roller and Cutters in the dishwasher, or immerse in water or other liquids. The Pasta Roller and Cutters should be hand washed.

1. Turn Stand Mixer off and unplug.

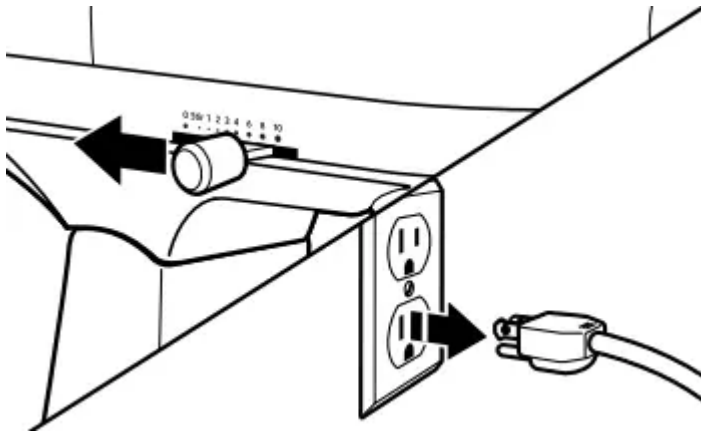

2. Completely disassemble Pasta Roller and Cutters. Use the directions from the “Disassembling the Pasta Roller and Cutters” section.

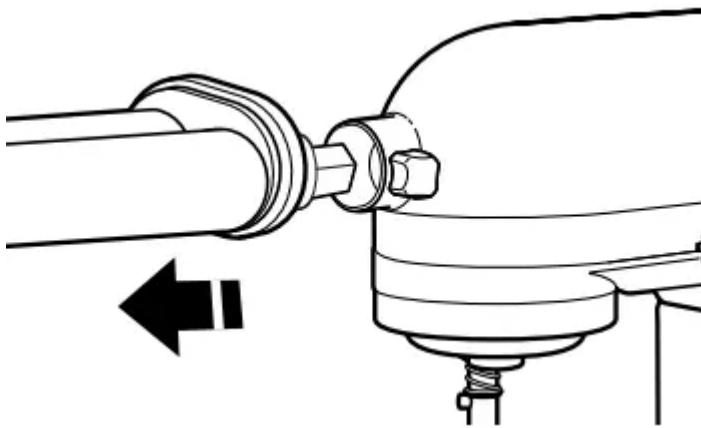

3. After cutting pasta, let Pasta Roller and Cutters air dry for one hour, then remove any dried dough using the Cleaning brush. If dried dough is difficult to remove, try tapping the attachment with your hand. Use a toothpick if necessary.

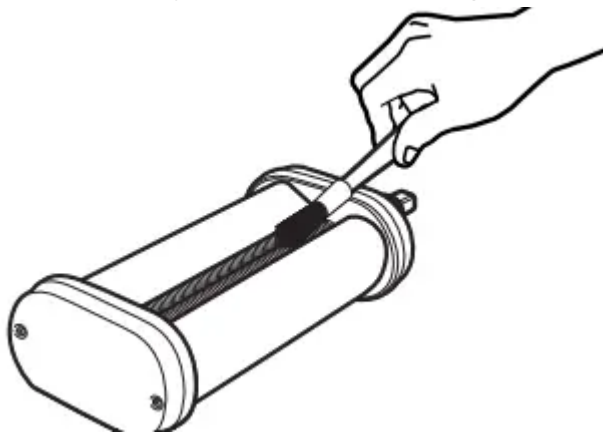

4. After cleaning out all remaining dried dough, polish the Pasta Roller and Cutters with a soft, dry cloth and store in a dry place at room temperature. Do not wash the Pasta

Roller and Cutters in the dishwasher.

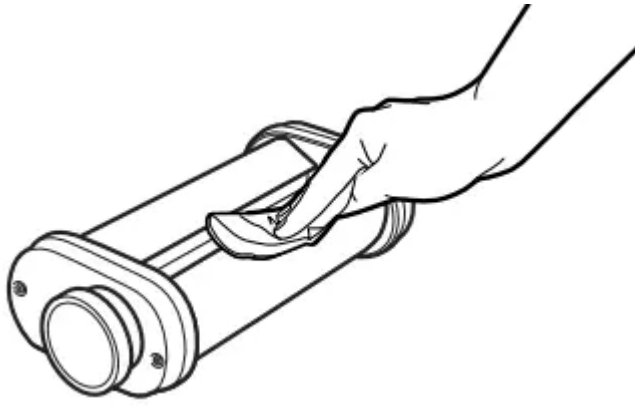

**NOTE:** Never use a knife or any other sharp object to remove excess dough. Do not run a dish towel or any other cloth through the rollers to clean them.

## MAINTENANCE

To maintain properly (annually or after 50 uses) we recommend using a light mineral oil to lubricate the gears. Add a drop of mineral oil to each of the 4 corners of the Pasta Roller and Cutters

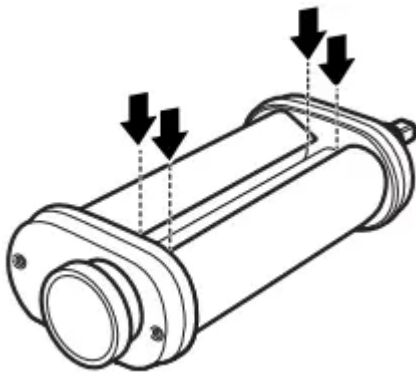

## TROUBLESHOOTING

**WARNING:** Electrical Shock Hazard

- Plug into a grounded 3 prong outlet.
- Do not remove ground prong
- Do not use an adapter
- Do not use an extension cord
- Failure to follow these instructions can result in death, fire, or electrical shock

If your Stand Mixer should malfunction or fail to operate while using the Pasta Roller and Cutter attachment, please check the following:

1. Is the Stand Mixer plugged in?

2. Is the fuse in the circuit to the Stand Mixer in working order? If you have a circuit breaker box, be sure the circuit is closed.
3. Turn off the Stand Mixer for 10-15 seconds, then turn it back on. If the Stand Mixer still does not start, allow it to cool for 30 minutes before turning it back on.
4. Did you use the correct speed for the Pasta Roller and Cutters as suggested in the “Roller Settings Chart?”
5. Did you attach the Pasta Roller or Cutter attachment properly as shown in the “Using the Pasta Roller and Cutters” section?
6. Did you follow the usage instructions as described in the “Using the Pasta Roller and Cutters” section?
7. Is your dough prepared according to the recipe?

If the problem is not due to one of the above items, see the “Arranging for Service” section in the “Warranty”.

Do not return the Pasta Roller and Cutter attachments or the Stand Mixer to the retailer, as they do not provide service.

**Warning**

This content is compiled from multiple sources and is provided for reference purposes only. It may not be complete or fully applicable to all situations. If you are unable to resolve your issue, please contact the product manufacturer or an authorized service provider for official support.

