

INSTALLATION

Unpacking

WARNING! Remove all the packaging and the transit bolts before installing the appliance.

WARNING! Use the gloves.

1. Remove the external film. If necessary, use a cutter.

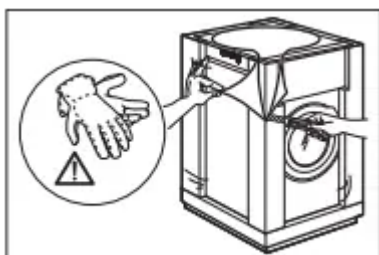

2. Remove the cardboard top and the polystyrene packaging materials.

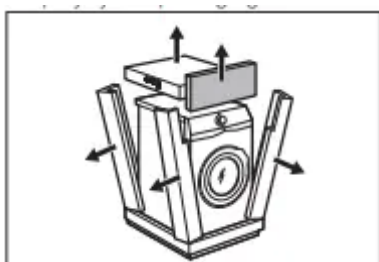

3. Remove the internal film.

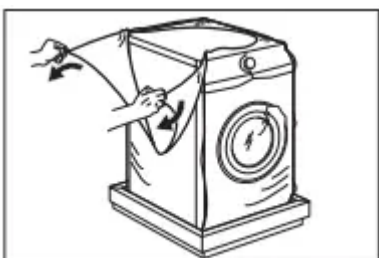

4. Open the door and remove the polystyrene piece from the door seal and all the items from the drum.



5. Carefully put the appliance down on its rear side.

6. Put the front polystyrene packaging element on the floor under the appliance

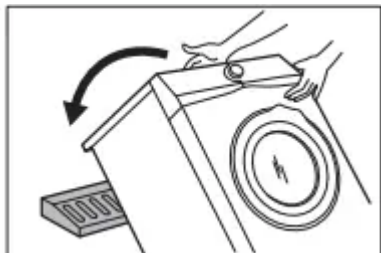

7. Remove the polystyrene protection from the bottom.

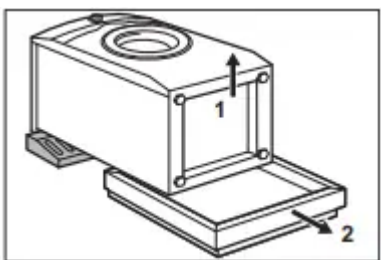

8. Fully clean and dry the bottom of the appliance.

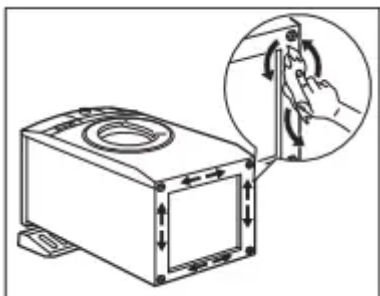

9. Make sure to identify the different sizes and the positions of the sound barriers. Refer to the illustration:

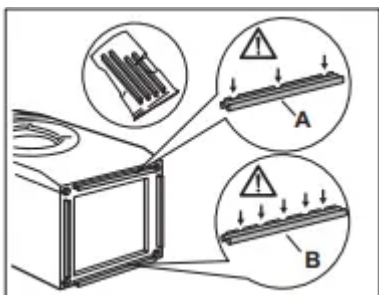

- A (FRONT) = Front of the appliance
- B (BACK) = Rear of the appliance

10. Remove the adhesive strip from the silent barriers.

11. Attach the four barriers to bottom of the appliance.

12. Refer to the illustration. Make sure that the barriers are securely attached.

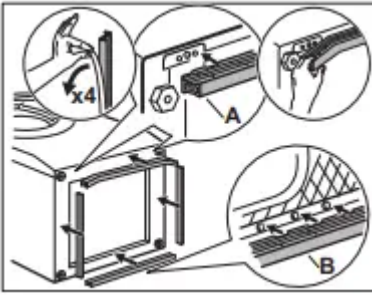

13. Pull up the appliance in vertical position.

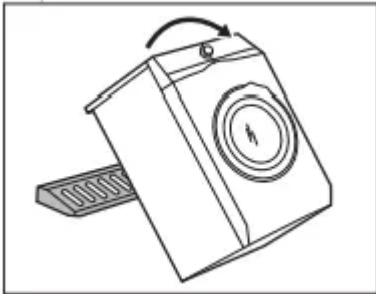

14. Remove the power supply cable and the drain hose from the hose holders.

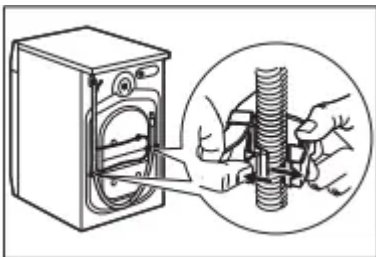

15. Remove the three bolts by using the spanner supplied with the appliance.

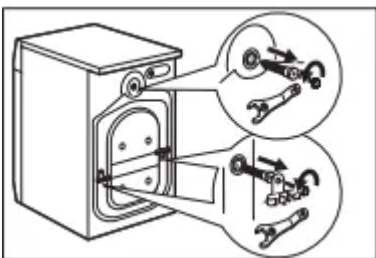

16. Pull out the plastic spacers.

17. Put the plastic caps, that you find in the user manual bag, in the holes.

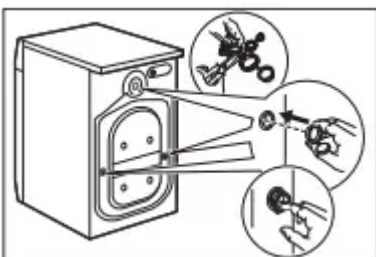

Installation on suspended flooring

Suspended wooden floors are particularly susceptible to vibration.

To limit vibration we recommend placing a waterproof wooden panel, at least 15 mm thick, under the appliance. It should be screwed to at least 2 floor beams and should extend beyond the front feet. If possible, install the appliance where the floor is more stable.

Positioning and levelling

1. Install the appliance on a flat hard floor.

Make sure that the appliance does not touch the wall or other units.

2. Loosen or tighten the feet to adjust the level.

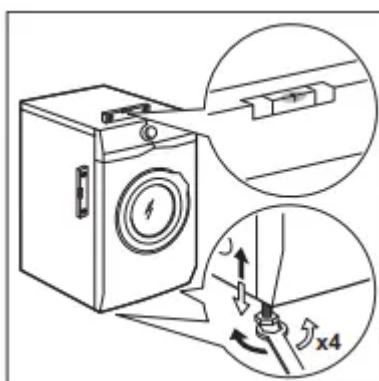

The appliance must be level and stable.

A correct adjustment of the appliance level prevents the vibration, noise and the movement of the appliance when in operation.

When the machine is installed on a plinth or if a washer dryer is stacked on the washing machine, use the accessories described in chapter 'Accessories'. Read carefully the instructions supplied with the appliance and with the accessory.

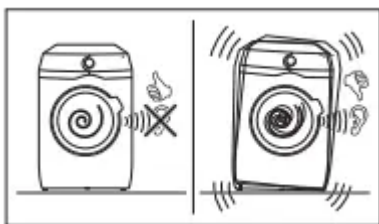

The inlet hose

1. Connect the water inlet hose to the back of the appliance.

2. Position it toward left or right depending on the position of the water tap

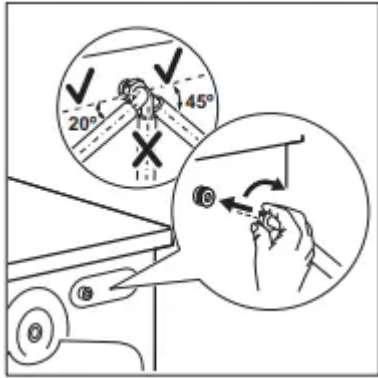

3. If necessary, loose the ring nut to set it in the correct position.
4. Connect the water inlet hose to the cold water tap with 3/4" thread.

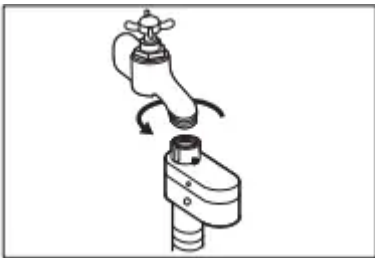

Water drainage

The drain hose should be positioned at a height of not less than 60 cm and not more than 100 cm from the floor

It is possible to connect the drain hose in different ways:

1. Make a U shape with the drain hose and put it around the plastic hose guide.

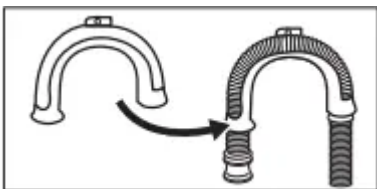

2. On the edge of a sink - Fasten the guide to the water tap or to the wall.



3. To a stand pipe with vent-hole - Insert the drain hose directly into a drain pipe. Refer to the illustration.

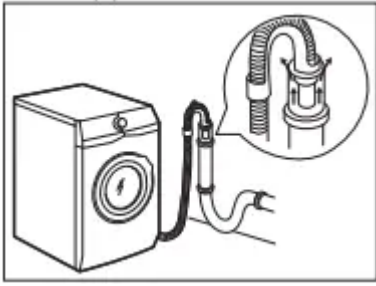

4. If the end of the drain hose looks like this (see the picture), you can push it directly into the stand pipe.

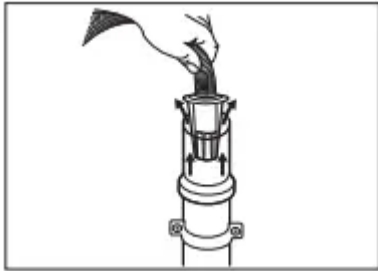

5. Without the plastic hose guide, to a sink spigot - Put the drain hose in the spigot and tighten it with a clamp. Refer to the illustration.

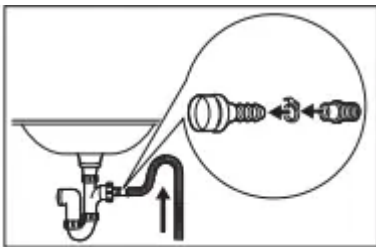

6. Position the hose directly to a built in drain pipe in the room wall and tighten it with a clamp

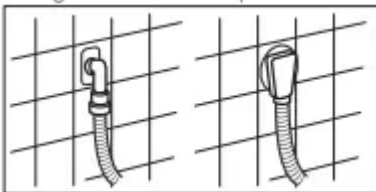

PRODUCT DESCRIPTION

Special features

Your new washing machine meets all modern requirements for an effective treatment of laundry with low water, energy and detergent consumption and proper care of fabric.

- The AutoDose technology automatically dispenses the right amount of detergent according to the load; the drawer has two integrated tanks (detergent + softener) and two additional compartments for detergent and additives manual load.
- It gives the highest use flexibility.

- The Wi-Fi connection and Remote
- Start enable you to start a cycle, to interact with your washing machine and to check the washing cycle status in remote control.
- The Oko-Mix technology has been designed to protect the fabric fibres thanks to different pre-mixing phases that dissolves first the detergent and then fabric softener in the water before they are distributed in the laundry. So every fibre is reached and cared for.
- The ProSense technology detects the laundry load size defining the programme duration in 30 seconds. The washing programme is tailored to the laundry load and the type of fabric without consuming more time, energy and water than necessary.
- The steam has a quick and easy way to refresh the clothes. The gentle steam programmes remove odours and reduce creases in dry fabrics so they need little ironing. The Plus Steam option, finishes every cycle with gentle steam that relaxes the fibres and reduces fabric creasing. Ironing will be easier!
- The Intensive option pre-treats stubborn stains optimizing the effectiveness of washing performance.

Appliance overview

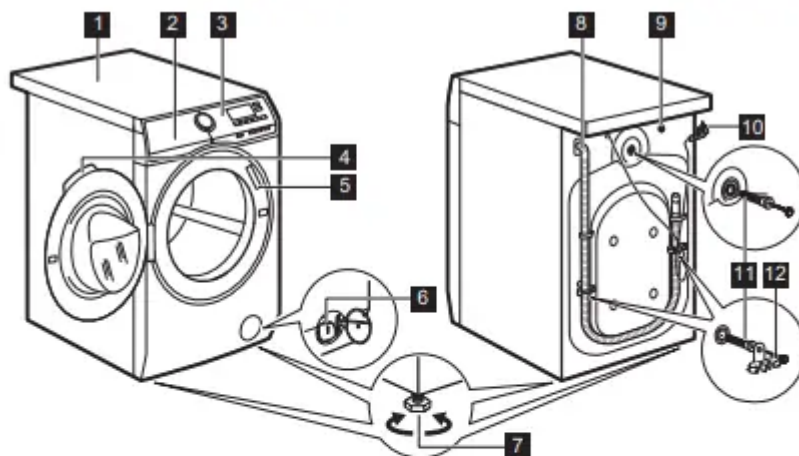

- | | |
|--|---|
| 1 Worktop | 7 Feet for levelling the appliance |
| 2 Detergent dispenser with AutoDose tanks and manual compartments | 8 Drain hose |
| 3 Control panel | 9 Inlet hose connection |
| 4 Door handle | 10 Mains cable |
| 5 Rating plate | 11 Transit bolts |
| 6 Drain pump filter | 12 Hose support |



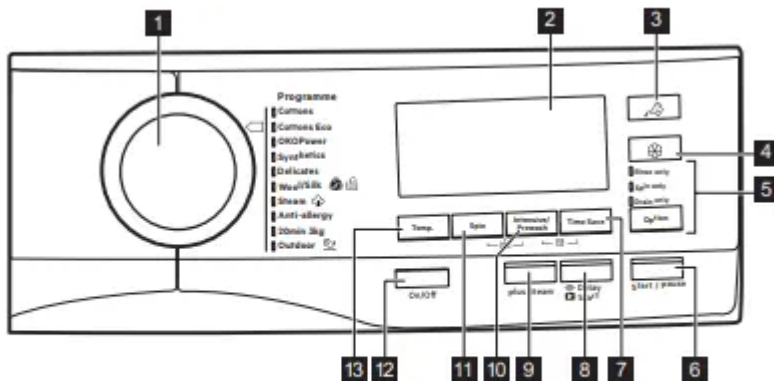

CONTROL PANEL















Control panel description



i The options are not selectable with all washing programmes. Check the compatibility between options and washing programmes in the "AutoDose and options compatibility with programmes" paragraph in the "Programmes" chapter. An option can exclude another one, in this case the appliance doesn't allow you to set the incompatible options together. Make sure the screen and touch buttons are always clean and dry.

1	Programme dial	For selecting the desired washing programme. Refer to "Programmes" chapter for more details.
2	Display	It provides information about the setting programme. Refer to "Display" paragraph for more details.
3	AutoDose Liquid Detergent touch button	For activating and deactivating the automatic detergent loading. Refer to "The AutoDose Technology (Autodosing)" chapter for more details.
4	AutoDose Fabric Softener touch button	For activating and deactivating the automatic fabric softener loading. Refer to "The AutoDose Technology (Autodosing)" chapter for more details.

<p>5 Option - Skipping phase touch button</p>	<p>By touching this button you can set:</p> <ul style="list-style-type: none"> • Rinse Only at first touch. The washing programme starts from the rinsing phase by skipping the washing phase. <p> All set options (except permanent extra rinse) are deselected automatically.</p> <ul style="list-style-type: none"> • Spin Only at second touch. The appliance skips washing and rinsing phase. • Drain Only. at third touch. The appliance performs the draining phase only. <p> At fifth touch, the appliance proposes the default setting of the washing programme again.</p>
<p>6 Start/Pause touch button</p>	<p>Touch this button to start, pause the appliance or interrupt a running programme.</p>
<p>7 Time Save touch button</p>	<p>With this option you can decrease the programme duration:</p> <ul style="list-style-type: none"> • If your laundry is normally or lightly soiled, it may be advisable to shorten the washing programme. Touch this button once to decrease the duration. • In case of smaller load, touch this button twice to set an extra quick programme. <p>The display shows the indicator .</p> <p> This option can also be used to shorten the Steam programme duration.</p>

<p> 8 Remote/Delay Start touch button</p>	<p>Press this button repeatedly to activate one of the two options or both. The relevant indicator comes on in the display.</p> <ul style="list-style-type: none"> •  Remote Select this option to connect appliance with App. Touch this button, the display shows the indicator  blinking for a few seconds. After touching the Start/Pause button, the display shows the indicator  and the Remote is confirmed. <p> When touching the Start/Pause button after the indicator  stops blinking, the Remote Start is not activated, but the set programme starts.</p> <ul style="list-style-type: none"> •  Delay Start With this option you can delay the start of a programme in a more convenient time. Touch the button repeatedly to set the required delay. The time increases by steps of 30 minutes up to 90' and from 2 hours up to 20 h. After touching the Start/Pause button, the display shows the indicator  and the selected delay time and the appliance begins the countdown.
<p>9 Plus Steam touch button</p>	<p>This option adds a steam phase followed by a short anti-crease phase at the end of the washing programme. The steam phase reduces fabric creasing and facilitates the fabric ironing.</p> <p>The indicator  flashes on the display during steam phase.</p> <p> This option can increase the programme duration.</p> <p>When the programme stops the display shows a zero , the indicator  is steady on and the indicator  starts flashing. The drum performs smooth movements for about 30 minutes to keep the steam benefit. By touching any button the anti-crease movements stop and the door unlocks.</p> <p> A small laundry load helps to reach better results.</p>

Press this button repeatedly to activate one of the two options or both.
The relevant indicator comes on in the display.

-  **Intensive**

By setting this option, the indicator  appears close to detergent symbol, and the machine will automatically dose an extra amount of detergent when automatic detergent tank is enabled.



If automatic detergent tank is Off, it is possible to run this option as in traditional washing machine by filling detergent or additive in the manual compartment.

 If you press detergent tank button while Intensive option is active, AutoDose function is switched off, but Intensive option still remains active in manual mode.

-  **Prewash**









Use this option to add a pre-wash phase at 30 °C before the washing phase.

This option is recommended for heavily soiled laundry, especially if containing sand, dust, mud and other solid particles.





 When selecting a pre-wash phase and AutoDose is active, the appliance will automatically dose the detergent. When AutoDose is switched off, put the detergent/additive in a dosing ball inside the drum.

 The options can increase the programme duration.

10 Intensive/
Prewash touch
button









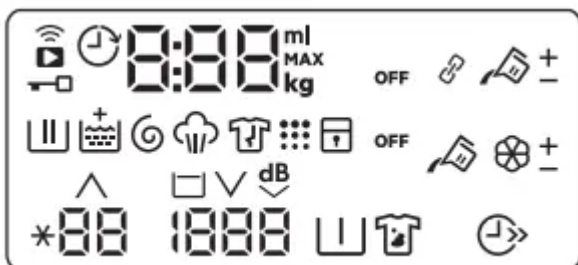









<p>11 Spin button</p>	<p>When you set a programme, the appliance automatically selects the maximum spin speed. Touch this button repeatedly to:</p> <ul style="list-style-type: none"> • Decrease the spin speed.  The display shows only the spin speeds available for the set programme. •  Activate the Rinse Hold option . The water of the last rinse is not drained out to prevent the fabrics from creasing. The washing programme ends with water in the drum and the final spin phase is not performed. The display shows the indicator  The door stays locked. The drum turns regularly to reduce creasing. You must drain the water to unlock the door. Touch Start/Pause button: the appliance performs the spinning phase and drains the water. •  Activate the Quiet option. All spinning phases (intermediate spin and final spin) are suppressed and the programme ends with water in the drum. This helps to reduce creasing. As the programme is very quiet, it is suitable for use at night time when cheaper electricity tariffs are available. In some programmes the rinses are performed with more water. The display shows the indicator  The door stays locked. The drum turns regularly to reduce creasing. You must drain the water to unlock the door. Touch the Start/Pause button button: the appliance performs only the draining phase. •  The appliance empties the water out automatically after approximately 18 hours.
<p>12 On/Off push button</p>	<p>Pressing this button for a few seconds allows to activate or deactivate the appliance. Two different tunes sound while switching the appliance on or off.</p> <p> As the Stand-by function automatically deactivates the appliance to decrease the energy consumption in a few cases, you may need to activate the appliance again. Refer to "Stand-by option" paragraph in "Daily Use" chapter for more details.</p>
<p>13 Temperature touch button</p>	<p>When you select a washing programme, the appliance automatically proposes a default temperature. Touch this button repeatedly until the desired temperature value appears on the display.</p> <p>When the display shows the indicators  and , the appliance does not heat the water.</p>















 Permanent Extra Rinse	<p>With this option you can permanently have an extra rinse. To activate/deactivate this option touch the Spin button and the Intensive/Prewash button simultaneously, the relevant indicator  comes on/goes off over rinse phase symbol. This option adds two rinses.</p>
 Child Lock	<p>With this option you can prevent that the children play with the control panel. To activate/deactivate this option, touch the Intensive/Prewash and the Time Save buttons simultaneously until the indicator  comes on/goes off on the display. You can activate this option:</p> <ul style="list-style-type: none"> • After you touch the Start/Pause button: all the buttons and the programme dial are deactivated (except On/Off button). • Before you touch the Start/Pause button: the appliance cannot start. <p>The appliance keeps the selection of this option after you switch it off.</p>
Acoustic signals	<p>This appliance is provided with different acoustic signals, that operate when:</p> <ul style="list-style-type: none"> • You activate the appliance (special short tune). • You deactivate the appliance (special short tune). • You touch the buttons (click sound). • You make a wrong selection (3 short sounds). • The programme is completed (sequence of sounds for about 2 minutes). • The appliance has a malfunction (sequence of short sounds for about 5 minutes). <p>To deactivate/activate the acoustic signals when the programme is completed, touch the Time Save and the Remote/Delay Start buttons simultaneously for about 6 seconds.</p> <p> If you deactivate the acoustic signals, they continue operate when the appliance has a malfunction.</p>

Display



	Wi-Fi connection indicator.
	Remote connection indicator.
	Delay start indicator.
	Door locked indicator.
	<p>The digital indicator can show:</p> <ul style="list-style-type: none"> • Maximum load indicator: e.g. Cottons 9.0. The kg icon flashes during laundry load estimation. Refer to "ProSense load detection" paragraph. • Programme duration: e. g. 2:40. • Delay time: e. g. 30' or 2h. • Cycle end: 0. • Alarm code: e.g. E2 1. • Liquid detergents and softener quantity indicator: 88". Refer to "The AutoDose technology (Autodosing)" chapter.
	Washing phase indicator: it flashes during prewash and wash phase.
	Rinsing phase indicator: it flashes during rinse phase.
	The + indicator appears when the Extra Rinse option is activated.
	Spin and drain phase indicator. It flashes during spin and drain phase.
	Steam phase indicator.
	Anti-crease phase indicator.
	Drum clean indicator. This is a recommendation to perform the drum cleaning.
	Child safety lock indicator.
	Time saving indicator.
	Temperature indicator. The * indicator appears when a cold wash is set.
	Spin speed indicator.
	These indicators appears when setting the automatic detergent or softener dosage. (refer to "The AutoDose technology (Autodosing)" chapter)
	Rinse hold indicator.

	Quiet indicator.
	Prewash indicator.
	Intensive indicator.
	AutoDose liquid detergent tank indicator. When it lights, appliance automatically doses the detergent.
	This indicator appears beside  when Intensive option is set.
	AutoDose fabric softener tank indicator. When it lights, appliance automatically doses the softener.
OFF	AutoDose status indicator. It lights when AutoDose function for additives is disabled.
Indicators for options downloadable via App only	
	Linked mode indicator. It lights when both AutoDose tanks are linked and filled with the same detergent. AutoDose function for softener is disabled: the indicator  disappears and the display shows two liquid detergent tank indicators  .
	These indicators will appear next to  and  when increasing or decreasing the automatic detergent or softener dosage.

THE AUTODOSE TECHNOLOGY (AUTODOSING)

Introduction

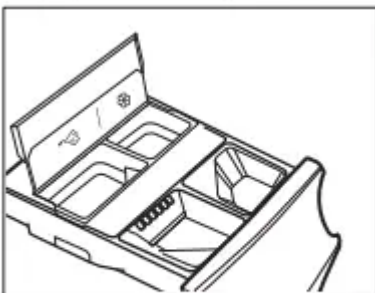

Right detergent and fabric softener dosage takes better care of the laundry and ensuring good wash performances

Too much detergent damages your clothes and too little doesn't ensure good wash performances. This appliance is equipped with an auto dosing system able to automatically provide the right detergent and fabric softener dosage to preserve the fabric integrity and colour brightness.



 AutoDose detergent tank.

 AutoDose fabric softener tank.





The appliance is pre-set by the factory to suit most users habits. Once started the programme, the appliance will automatically release the right amount of detergent and softener according to the real fabric load, if the indicators  and/or  are on in the display.

Detergent dispenser with AutoDose tanks and manual compartments

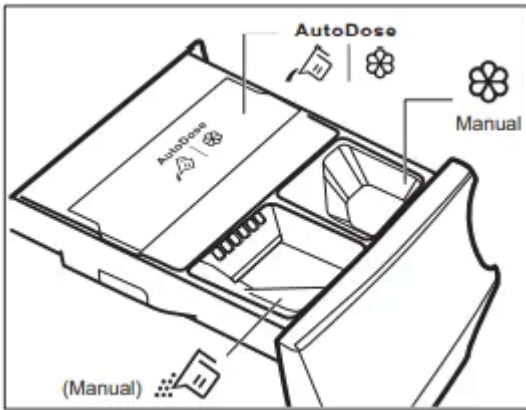
If both AutoDose tanks are enabled in the set programme, liquid detergent and fabric softener are automatically loaded.

If one of the AutoDose tank or both are disabled (OFF) in the set programme, proceed by manually filling the product in the proper compartment.



-  |  AutoDose tanks for liquid detergent  and fabric softener .
-  Manual compartment for washing phase: powder or liquid detergent.

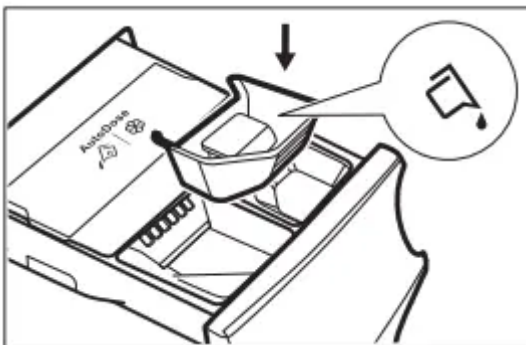

-  Manual Manual Manual compartment for liquid additives (fabric softener, fabric conditioner, starch).
- **MAX** Maximum level for detergent/ additives quantity

AutoDose basic setting

The factory pre-set doses for a large load are 90 ml for detergent tank and 25 ml for fabric softener tank: the optimal configuration to meet majority of use condition. Based on this setting, the appliance will calculate the precise dosage for each wash.

However, under extreme conditions (very soft or very hard water) and particular type of detergent (such as super compact), we recommend to adjust the pre-set dosage by following the indication given on detergent and fabric softener container: e.g when using super compact detergent you may need to reduce the pre-set dosage considerably. If the washing results are not satisfying or

there is too much foam during washing, you may need to change the factory setting. Read in the paragraph 'AutoDose configuration mode' how to change the basic setting, but before:

1. Identify the water hardness level.

Check the water hardness level in your area. The levels are generally indicated as: soft, medium and hard. If necessary, please contact your local water authority to check the water hardness in your area.

2. Identify the customized detergent dosage.

Check the label in the detergent/ fabric softener container suggesting the quantity to use. This suggestion is measured combining three different factors:

- Water hardness level (see the following table);
- Normal soil level;
- Rated capacity of the appliance (e.g. maximum load capacity 9 kg). If the rated capacity on the product container refers to lower capacity appliances, the customized dosage should be increased.

Water hardness levels

Levels	Water hardness range				
	°f ¹⁾	°d ²⁾	°e ³⁾	mmol/l	ppm
Soft	<15	<8	<10	<1.4	<140
Medium ⁴⁾	15 - 25	8 - 14	0 - 17	1.5 - 2.5	150 - 250
Hard	>25	>14	>17	>2.5	>250

1) French degrees

2) German degrees

3) English degrees



4) Factory setting, able to satisfy most of the use conditions.

AutoDose configuration mode

Enter the AutoDose configuration mode before proceeding with any programme setting. The configuration mode may cancel temporary settings .

1. Press the On/Off button for a few seconds to activate the appliance.

2. Wait about 10 seconds for appliance internal check.

3. To enter in configuration mode, hold pressed the Temperature and the Spin buttons simultaneously for a few seconds until the display shows the **SEE** on the left in the display and blinking detergent tank  and softener tank  indicators on the right in the display.

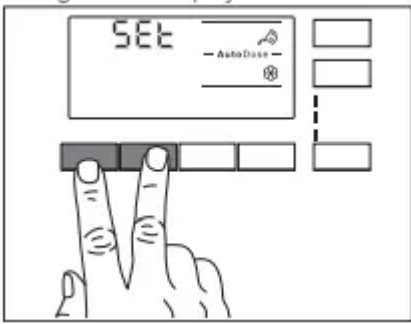

4. Touch related tank buttons to toggle function off and on. The display shows OFF when a tank is disabled or shows tank indicator when it is enabled.

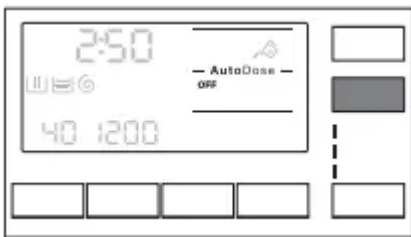

5. To set basic dosage touch related tank buttons until default dosage laundry product and two arrows on bottom of display appear. Touch the Temperature button repeatedly to adjust the dosage upwards and the Spin button to adjusts it downwards. Minimum step is 1 ml.



6. After about 10 seconds the display returns to the programme information screen or hold pressed the Temperature and the Spin buttons again to exit immediately.

Filling the detergent and additives on AutoDose system

1. Open the detergent dispenser.

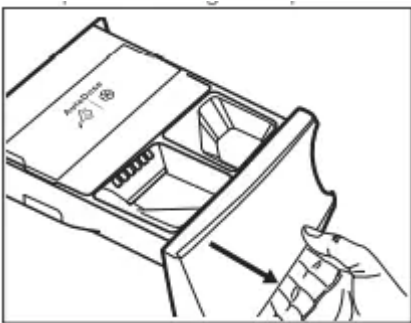

2. Lift up the AutoDose cover lid.

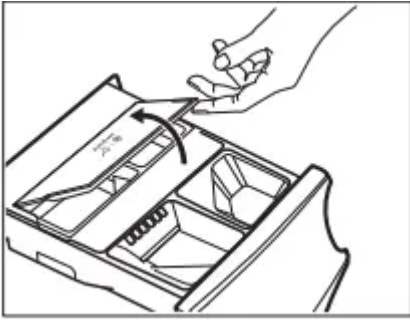

3. Gently pour only liquid detergent in the AutoDose detergent tank . Fill up to the maximum indicated level **MAX**

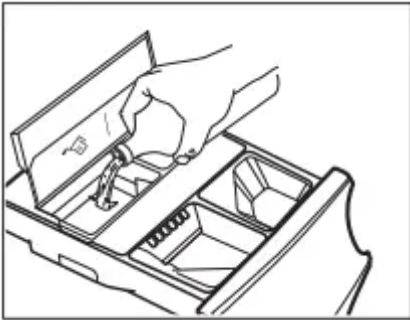

4. Gently pour only liquid softener in the AutoDose fabric softener tank . Fill up to the maximum indicated level **MAX**.

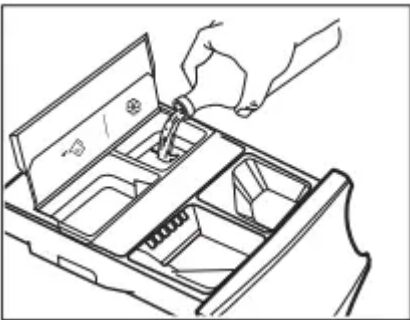

5. Lift down the AutoDose cover lid.

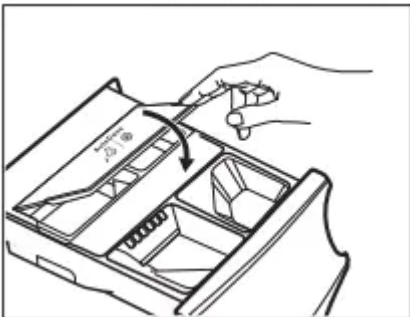

6. Gently close the detergent dispenser, till click engagement.

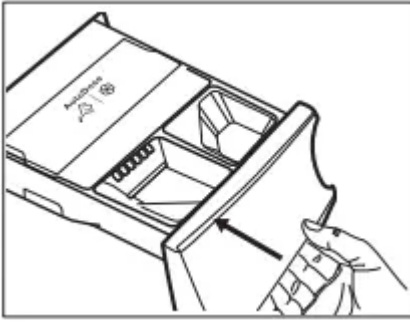

AutoDose low level indication

Do not refill the AutoDose tanks unless appliances indicates that one or both tanks are empty.

When the activated tank reaches a low level of detergent, related indicator blinks slowly and continuously on the display.

It will stop blinking when the compartment is refilled. If tank is not refilled, once a programme has started, the indicator will stop blinking and stay steadily lit. Once the programme is finished, it will start blinking again.

Unless AutoDose is turned OFF, if a compartment has reached low level, the set dosage for that compartment will be shown by the display for a few seconds each time the drawer is opened, to remind refill is needed.

If in both tanks detergent level is low, both indicators blink, but only the set dosage for detergent will be displayed.

Switching from AutoDose to manual dosing

It is possible to disable AutoDose function for one or both tanks by pressing related button symbol.

Example:

- To switch Fabric Softener tank off, press the  button until the display shows OFF.

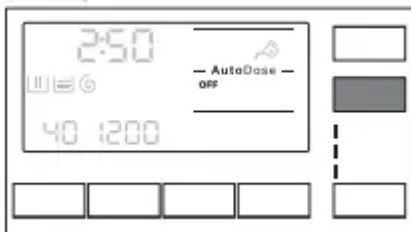

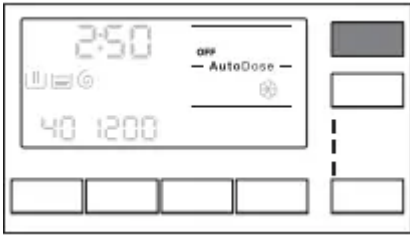

- If you need to use different detergent than ones present in AutoDose tanks, you could switch Detergent tank off by pressing  button until the display shows OFF.



Deactivating the AutoDose

If you prefer to use the compartments for manual filling as default choice, you can deactivate the AutoDose tanks completely. Once you have entered the AutoDose configuration mode by pressing Temperature and the Spin buttons:

1. Tap on the  button or  button until display shows OFF: the AutoDose is excluded completely for related tank or both.

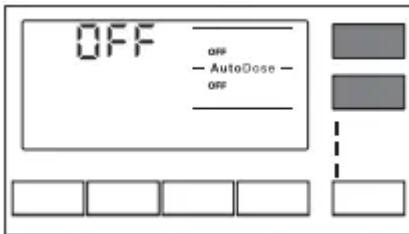



2. After about 10 seconds the display returns to the programme information screen.

Manual filling the detergent and additives

You may need to use a different detergent or fabric softener than the ones used in the AutoDose tanks. First, make sure that the AutoDose tanks are disabled and then pour the detergent and/or other treatments in the manual compartments.

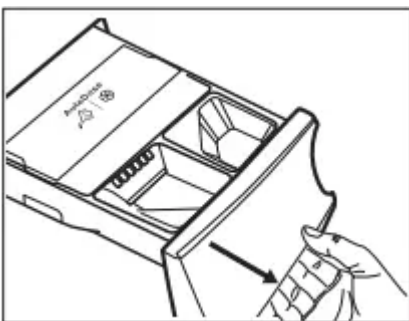
1. Open the detergent dispenser.



2. Put the powder detergent in the compartment . When using liquid detergent, refer to "Manual filling the liquid detergent".

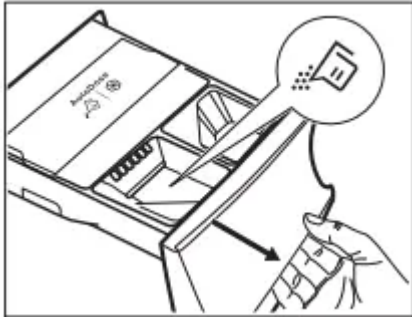

3. If desired, pour the fabric softener in the compartment

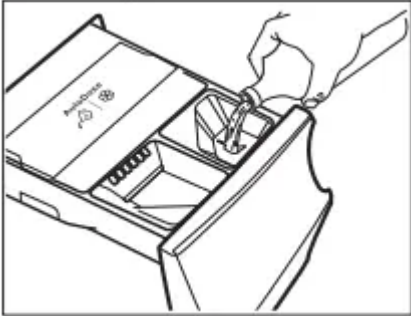

4. Gently close the detergent dispenser, till click engagement.

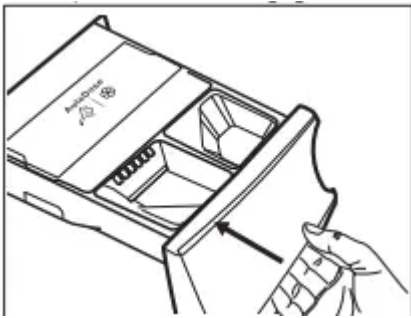

Manual filling the liquid detergent

1. Insert the container for liquid detergent.

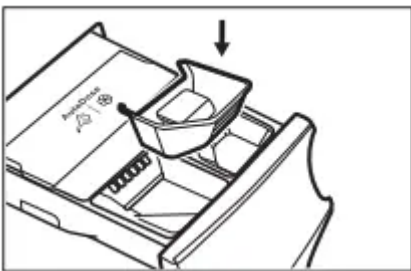

2. Pour the liquid detergent in the compartment .

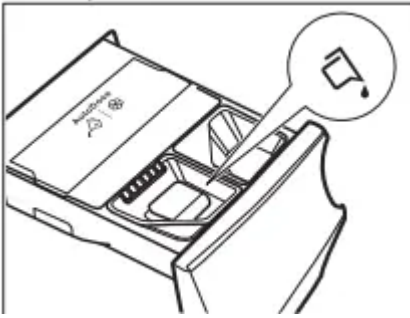

3. Gently close the detergent dispenser, till click engagement.

Drawer open indication

When a programme is running, the detergent drawer must always be closed. A sensor in the drawer detects if the drawer is open (or not properly closed) while the programme is running. In such case, the appliance will immediately be paused.





If you press the Start/Pause button, an error sound is generated and everything in the display will turn off except the AutoDose indicators remain lit for a few seconds. Then the display returns to the previous paused state.





This will happen even if the user turned AutoDose off. To restart the programme, ensure the drawer is properly closed and press Start/Pause button.

PROGRAMMES



Programme Chart

Washing programmes

Programme	Programme description
Washing programmes	
 Cottons	White cotton and coloured cotton. Normal, heavy and light soil.
 Cottons Eco ¹⁾	White cotton and coloured cotton. Normal, heavy and light soil.
OKOPower	Cotton and fast-coloured synthetic items. Complete washing programme that, in only 59 minutes, washes the daily soiled laundry intensively and ensures a good washing performance in a short time.
Synthetics	Synthetic items or mixed fabric items. Normal soil.
Delicates	Delicate fabrics such as acrylics, viscose and mixed fabrics requiring gentler washing. Normal soil.
 Wool/Silk	Machine washable wool, hand washable wool and other fabrics with «hand washing» care symbol ²⁾ .
Steam programme	
 Steam	Steam programme for cotton and synthetic items. Steam can be used for dried ³⁾ , washed or worn once laundry. This programme reduce creases and odours ⁴⁾ and relaxes the fibres. When the programme is completed, quickly remove the laundry from the drum. After a steam programme, ironing becomes effortless. Do not use any detergent. If necessary, remove stains by washing or using localized stain removal. Steam programmes do not perform any hygienic cycle. Do not set a Steam programme with these types of items: <ul style="list-style-type: none"> • Items that are not suitable for tumble drying. • Items with label "Dry clean only".
Washing programmes	

Programme	Programme description
Anti-allergy	White cotton items. This programme removes micro-organisms thanks to a washing phase with the temperature maintained above 60°C for several minutes. This helps remove germs, bacteria, micro-organism and particles. An additional rinsing phase ensures a proper removal of detergent residues and pollens/allergenic items. In this way the wash is more effective.
20min 3kg	Cotton and synthetic items lightly soiled or once worn.
 Outdoor	<p> Do not use fabric softener and make sure that there is no softener residue in the detergent dispenser.</p> <p>Outdoor clothing, technical, sport fabrics, waterproof and breathable jackets, shell jackets with a removable fleece or inner insulation. The recommended laundry load is 2.5 kg. This programme can also be used as water-repellent restoring cycle, specifically tailored for treating clothes with a hydrophobic coating. To perform the water-repellent restoring cycle, proceed as follows:</p> <ul style="list-style-type: none"> • Pour the washing detergent in the compartment . • Pour a special water-repellent restorer for fabric in the drawer compartment for fabric softener  <small>Manual</small>. • Reduce the laundry load to 1 kg. <p> To further improve the water-repellent restoring action, dry the laundry in a tumble dryer by setting the Outdoor drying programme (if available and if the garment care label permits tumble drying).</p>

1) Standard programmes for the Energy Label consumption values. According to regulation

1061/2010, the programmes Cottons Eco  at 60 °C and the programme Cottons Eco  at 40 °C are respectively the «Standard 60°C cotton programme» and the «Standard 40°C cotton programme». They are the most efficient programmes in terms of combined energy and water consumption for washing normally soiled cotton laundry. Powder detergent and fabric softener have to be filled in the proper manual compartment. Make sure that the AutoDose tanks are disabled.



The water temperature of the washing phase may differ from the temperature declared for the selected programme.

2) During this cycle the drum rotates slowly to ensure a gentle wash. It can seem that the drum doesn't rotate or doesn't rotate properly, but this is normal for this programme.

3) If you set a Steam programme with dried laundry, at the end of the cycle the laundry can be humid. Line dry the items for about 10 minutes.

4) Steam programme doesn't remove particularly intense odour.

Programme temperature, maximum spin speed and maximum load



Programme	Default temperature Temperature range	Reference spin speed Spin speed range	Maximum load
Washing programmes			
Cottons	40 °C 95 °C - Cold	1600 rpm 1600 rpm - 400 rpm	9 kg
Cottons Eco	40 °C 60 °C - 40 °C	1600 rpm 1600 rpm - 400 rpm	9 kg
OKOPower	30 °C 60 °C - 30 °C	1600 rpm 1600 rpm - 400 rpm	5 kg
Synthetics	40 °C 60 °C - Cold	1200 rpm 1200 rpm - 400 rpm	4 kg
Delicates	30 °C 40 °C - Cold	800 rpm 1200 rpm - 400 rpm	2 kg
 Wool/Silk	40 °C 40 °C - Cold	1200 rpm 1200 rpm - 400 rpm	1.5 kg
Steam programme			
 Steam	-	-	1 kg
Washing programmes			
Anti-allergy	60 °C	1600 rpm 1600 rpm - 400 rpm	9 kg
20min 3kg	30 °C 40 °C - 30 °C	1200 rpm 1200 rpm - 400 rpm	3 kg
 Outdoor	30 °C 40 °C - Cold	1200 rpm 1200 rpm - 400 rpm	2.5 kg ¹⁾ 1 kg ²⁾

1) Washing programme.

2) Washing programme and waterproofing phase.



AutoDose and options compatibility with programmes

	Cottons	Cottons Eco	OKOPower	Synthetics	Delicates	Wool/Silk	Steam	Anti-allergy	20min 3kg	Outdoor
AutoDose										
 AutoDose Detergent	■	■	■	■	■			■	■	■
 AutoDose Fabric Softener	■	■	■	■	■	■		■	■	
Others										
Spin	■	■	■	■	■	■		■	■	■
 Rinse Hold	■	■	■	■	■	■		■		■
 Quiet	■		■	■	■					
 Intensive ¹⁾	■	■		■				■		
 Prewash	■	■		■				■		
 Extra Rinse	■	■	■	■	■			■		■
Time Save ²⁾	■	■		■	■		■			
Rinse Only	■	■		■	■	■		■	■	■
Spin Only	■	■	■	■	■	■		■	■	■
Drain Only	■	■	■	■	■	■		■	■	■

	Cottons	Cottons Eco	OKOPower	Synthetics	Delicates	Wool/Silk	Steam	Anti-allergy	20min 3kg	Outdoor
Delay Start	■	■	■	■	■	■	■	■	■	■
Plus Steam ³⁾	■	■		■				■		

1) This option is not available with temperature lower than 40 °C.

2) If you set the shortest duration, we recommend that you decrease the load size. It is possible to fully load the appliance, however the washing results can be less satisfactory.

3) This option is not available with temperature lower than 40 °C.

📶 WI-FI - CONNECTIVITY SETUP

This chapter describes how to connect the smart appliance to the Wi-Fi network and to link it to mobile devices. By this functionality you can receive notifications, control and monitor your washing machine from your mobile devices.

To connect the appliance to enjoy the full range of features and services you need:



- Wireless network at home with internet connection enabled.
- Mobile device connected to wireless network.

Frequency	2.412 - 2.472 GHz for European market
Protocol	IEEE 802.11b/g/n two stream radio
Max Power	<20dBm

Configuring the washing machine wireless connection

1. Press and hold the On/Off button for a few seconds to activate the appliance. Wait about 10 seconds before proceeding with wireless configuration.

2. Press and hold the  and the  buttons for a few seconds simultaneously until a 'click' sounds.

Release the buttons.  appears on the display for 5 seconds and the indicator  starts blinking.

The wireless module begins starting up.

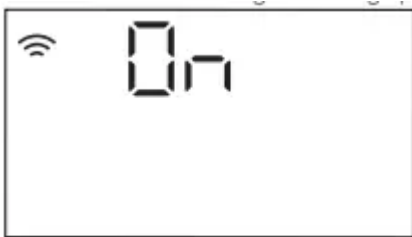

3. After about 45 seconds, **AP**(Access Point) appears on the display.



The access point will be open for about 3 minutes.

4. Configure the "My AEG" app on your smart device and follow the instructions to connect the appliance to your Wi-Fi network.

5. If the connectivity is configured, when the programme information screen returns, the indicator is on the display.



Remote Start



The Remote Start enables you to start a cycle in remote control.

When the App is installed and the wireless connection is complete, you can activate the Remote Start:

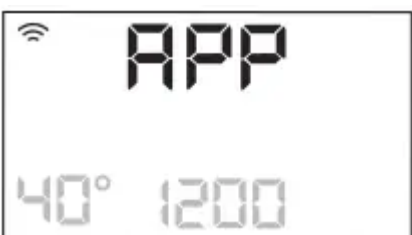
1. Touch the Remote  button and the indicator **APP** blinks on the display for a few seconds.



2. Touch the Start/Pause button to activate the Remote Start before the indicator **APP** stops blinking.

The indicators  and  appear on the programme summary screen and the door is locked. Now it is possible to start the programme remotely.

To remove the Remote Start, tap on the Remote  button and confirm by pressing the Start/Pause button.

DAILY USE

Activating the appliance

1. Connect the mains plug to the mains socket.
2. Open the water tap.
3. Press the On/Off button for a few seconds to activate the appliance.

A short tune sounds (if activated). The programme dial is automatically set on Cottons programme.

The display shows the programme duration, the maximum load (for a few seconds only), the default temperature, the default spin speed and the indicators of the phases making up the programme.

Loading the laundry

1. Open the appliance door.
2. Shake the items before you put them in the appliance.
3. Put the laundry in the drum, one item at a time.

Make sure not to put too much laundry in the drum.

4. Close the door firmly.

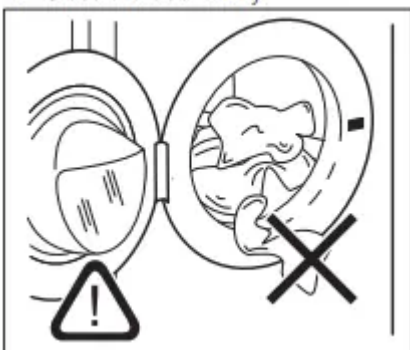

Setting a programme

1. Turn the programme dial to select the desired washing programme. The related programme indicator comes on.

The indicator of the Start/Pause button flashes.

The display shows an indicative programme duration, the maximum declared load for the set programme (only for a few seconds), the default temperature, the default spin speed and the washing phase indicators (when available).

2. To change the temperature and/or the spin speed, touch the related buttons.

3. If desired, set one or more options by touching the related buttons. The related indicators come on in the display and the given information changes accordingly.

Starting a programme

Touch the Start/Pause button to start the programme.

The related indicator stops flashing and stays on.

In the display, the indicator of the operating phase starts flashing. The programme starts, the door is locked. The display shows the indicator .

Starting a programme with the delay start

1. Touch this repeatedly until the display shows the desired delay time. The indicator  comes on.

2. Touch the Start/Pause button.

The appliance starts the countdown of the delay start. When the countdown is completed, the programme starts.

Cancelling the delay start after the countdown has started

To cancel the delay start:

1. Touch the Start/Pause button to pause the appliance. The related indicator flashes.

2. Touch the Delay Start button repeatedly until the display shows .

3. Touch the Start/Pause button again to start the programme immediately.

Changing the delay start after the countdown has started

To change the delay start:



1. Touch the Start/Pause button to pause the appliance. The related indicator flashes.

2. Touch the Delay Start button repeatedly until the display shows the desired delay time.

3. Touch the Start/Pause button again to start the new countdown.

The ProSense load detection

After touching the Start/Pause button, the maximum declared load indicator goes off, the indicator  flashes, the ProSense starts the laundry load detection:

1. The appliance detects the load in the first 30 seconds: the indicator  comes on and the indicator  flashes, the drum rotates shortly.

2. The appliance adjusts automatically the programme duration to the load to achieve perfect washing results in the minimum possible time. The programme duration could increase or decrease.

At the end of the load detection, if laundry load is below the maximum declared weight for selected programme, the display shows the new programme duration. After further 30 seconds, the water filling starts.

At the end of the load detection, in case of drum overload, the indicator **kg** is steady on and the indicator **MAX** is flashing in the display. In this case, for 30 seconds, it is possible to pause the appliance and remove the exceeding garments.

Once removed the exceeding garments, touch the Start/Pause button to start the programme again. The ProSense phase can be repeated up to three times (see point 1).

Programme phase indicators

When the programme starts the indicator of the running phase flashes and the other phase indicators are steady on.

E.g. the washing or pre wash phase is running: 

When the phase ends the relevant indicator stops flashing and is steady on. The next phase indicator starts flashing.

E.g. the rinse phase is running: 

If you select the Plus Steam the steam phase indicators come on. The steam phase is running:



The anti-crease phase is running: 

CARE AND CLEANING

External cleaning

Clean the appliance with mild soap and warm water only. Fully dry all the surfaces.

Descaling

If the water hardness in your area is high or moderate, we recommend that you use a water descaling product for washing machines.

Regularly examine the drum to check for limescale.

The regular detergents already contain water softening agents, but we recommend to run a cycle with empty drum and a descaling product occasionally.

Maintenance wash

The repeated and prolonged use of low temperature and short programmes can cause detergent deposits, fluff residues, bacterial growth and biofilm formation inside the drum and the tub. This could generate bad odours and mildew.

To eliminate these deposits and hygienize the inner part of the appliance, run a maintenance wash at least once a month:

1. Remove all laundry from the drum.
2. Deactivate AutoDose function for detergent and softener.
3. Add manually small quantity of powder detergent or a specific product and run a cotton programme with the highest temperature.

Door seal



Regularly examine the seal and remove all objects from the inner part.

Cleaning the drum

Regularly examine the drum to prevent unwanted deposits.

Rust deposits in the drum may occur due to rusting foreign body in the washing or tap water containing iron

Clean the drum with special products for stainless steel.

For a thorough clean:

1. Remove all laundry from the drum.
2. Deactivate AutoDose function for detergent and softener.
3. Run a Cottons programme with the highest temperature.
4. Add a manually small quantity of powder detergent or a specific product into the empty drum, in order to rinse out any left residues.

Occasionally, at the end of a cycle the display may show the icon  : this is a recommendation to perform the “drum cleaning”. Once the drum cleaning has been performed, the icon disappears.

Cleaning the detergent dispenser and the AutoDose tanks

To prevent possible deposits of dried detergent, clotted fabric softener, formation of mould in the detergent dispenser and/or clotted liquid additives in the AutoDose tanks, once in a while carry out the following cleaning procedure:

1. Open the detergent dispenser. Press the catch as indicated in the picture and pull the detergent dispenser out.

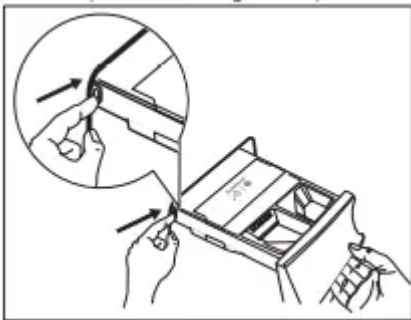

2. Remove the insert for the softener and, if inserted, the container for liquid detergent.

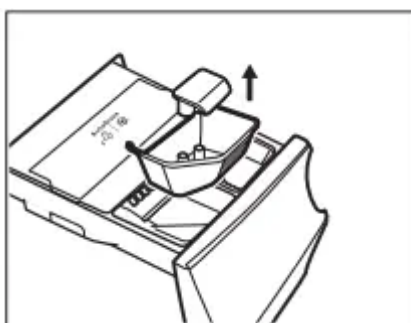
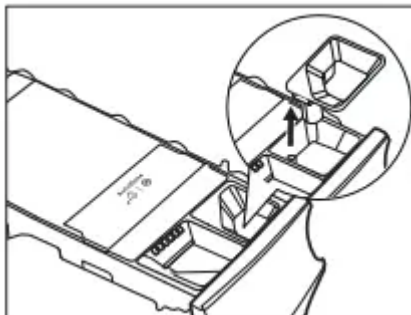

3. Open the drain plugs of each tank and empty them into a sink.

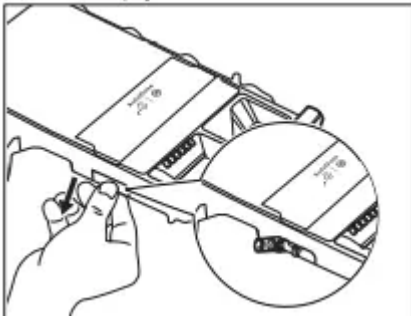

4. Press the catch on the back as indicated in the picture and lift up the top cover to remove it.

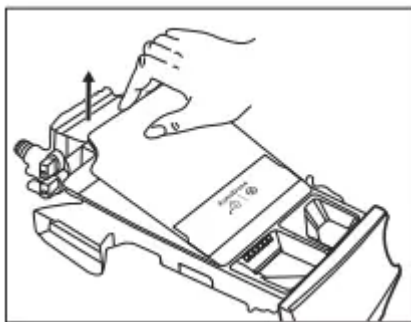
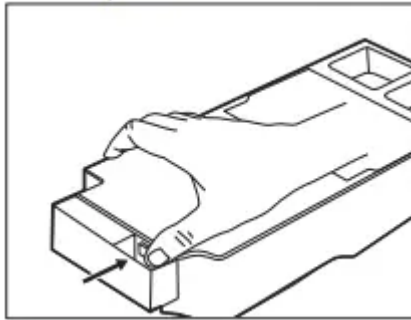

5. Wash the drawer and all inserts under running water.

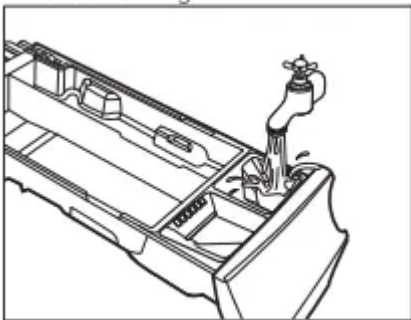

6. Turn the dispenser up side down and open the bottom cover as indicated in the picture.

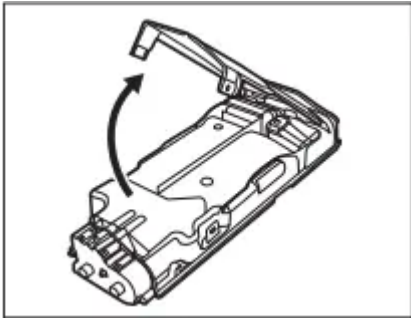

7. Make sure that all detergent residue is removed from the conveyor. Use only soft damp clothes.

8. Put bottom cover back to its position by aligning its holes on drawer hooks as indicated in the picture. Close it till "click" sound.

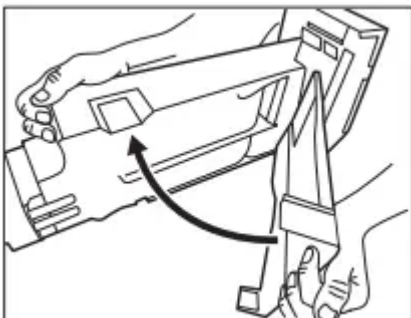

WARNING! Do not clean with any sharp and metal brushes ora any tools, pumps or sensors allocated on the back of the detergent drawer. If necessary, use only soft damp clothes.

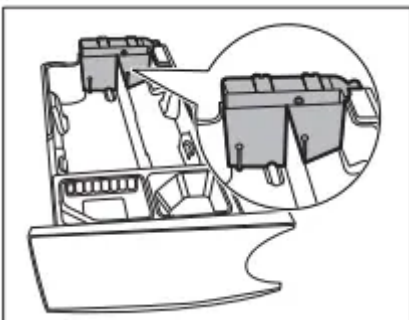

WARNING! If some residues remain on the back area of tanks, soak detergent drawer in a warm water. Do not use tools to clean it. Before soaking, remove the handle by pressing red button and slide the handle as indicated in the picture

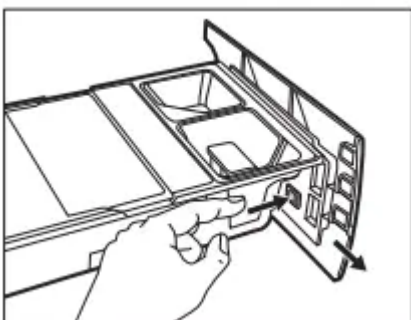

9. Make sure that all detergent residue is removed from the upper and lower part of the recess. Use a small brush to clean the recess.

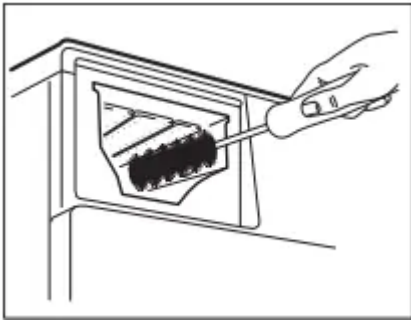

10. Reassembly the drawer as follows:

- a. Place the handle if was disassembled.
- b. Place the bottom cover and press till "click" sound.
- c. Place the top cover on the tanks compartment and press till "click" sound.
- d. Replace components on manual compartment.

11. Insert the detergent dispenser into the guide rails and gently close it till "click" sound. Run the rinsing programme without any clothes in the drum.

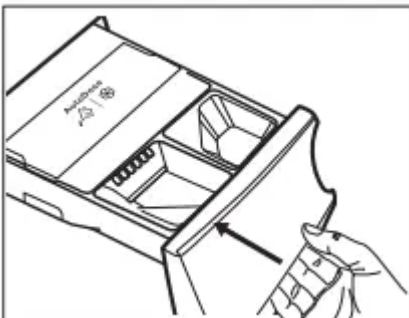

To restore the functionality, refill tanks with detergent and softener. If you place a wrong additives in the tanks, you can easily recover it by using the drain plug on both side of the drawer. Before opening drain plugs ensure to place below the drawer a basin or suitable containers to collect the liquid. Ensure to properly close the plugs before refilling.

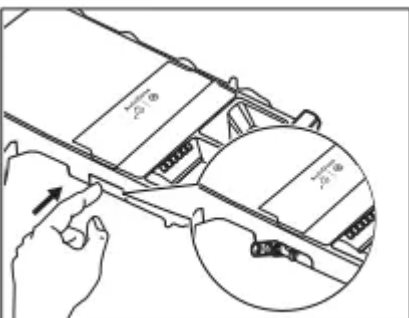

Cleaning the drain pump

Clean the drain pump if:

- The appliance does not drain the water.
- The drum does not turn.
- The appliance makes an unusual noise because of the blockage of the drain pump.
- The display shows the alarm code E21

Proceed as follows to clean the pump:

1. Open the pump cover.

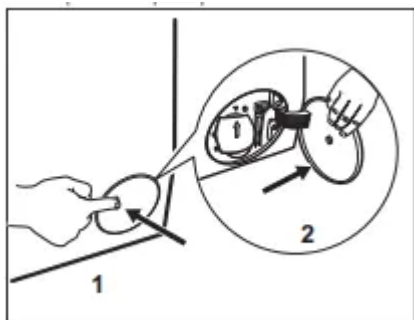

2. Place a suitable bowl below the drain pump access to collect the water that flows out.

3. Open the chute downwards. Always keep a rag nearby to dry up any water spillages when removing the filter.

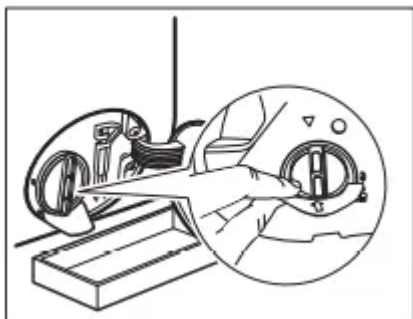

4. Turn the filter 180 degrees in anti clockwise direction to open it, without removing. Let the water flow out.

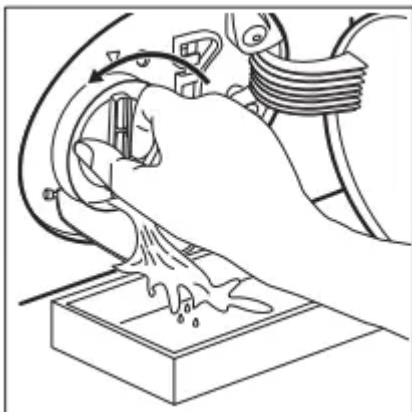

5. When the bowl is full of water, turn the filter back and empty the container.
6. Repeat the steps 4 and 5 until the water stops to flow out.
7. Turn the filter anti-clockwise to remove it.

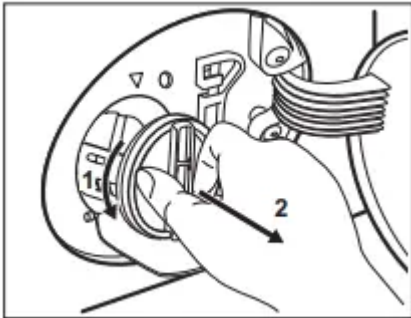

8. If it is necessary, remove fluff and objects from the filter recess.
9. Make sure that the impeller of the pump can rotate. If it does not rotate, contact the Authorised Service Centre.

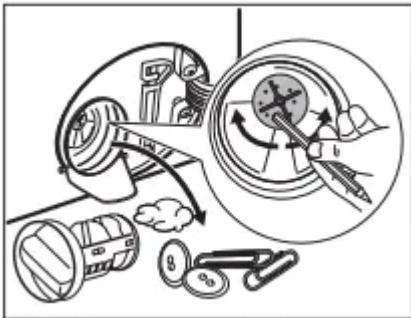

10. Clean the filter under the water tap.

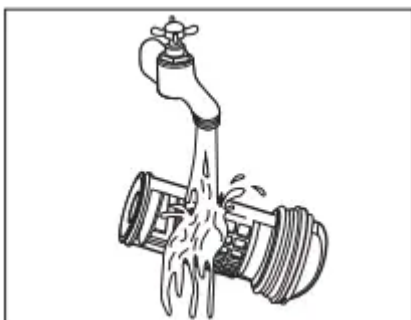

11. Put the filter back into the special guides by turning it clockwise. Make sure that you tighten the filter correctly to prevent leakages

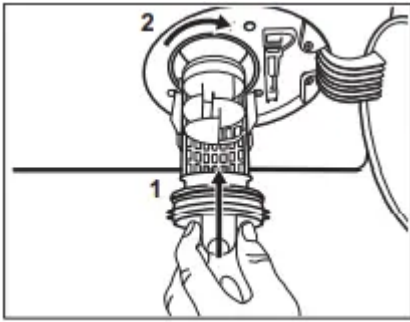

12. Close the pump cover.

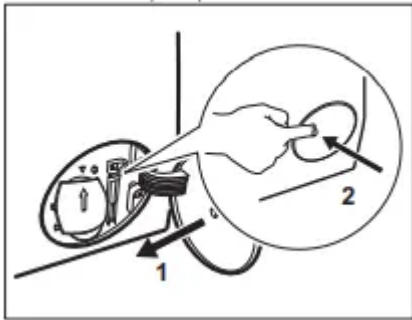

When you drain the water with the emergency drain procedure, you must activate the drain system again:

- a. Put 2 litres of water in the main wash compartment of the detergent dispenser.
- b. Start the programme to drain the water.

Cleaning the inlet hose and the valve filter

It is recommended to clean both the filters of the inlet hose and valve occasionally to remove any deposit, collected over the time:

1. Remove the inlet hose from the tap and clean the filter.

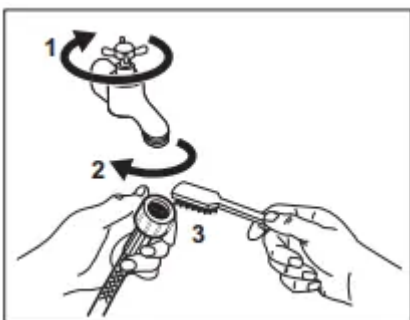

2. Remove the inlet hose from the appliance by loosening the ring nut.

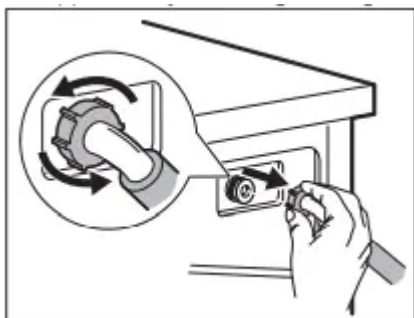

3. Clean the valve filter on the back of the appliance with a toothbrush.

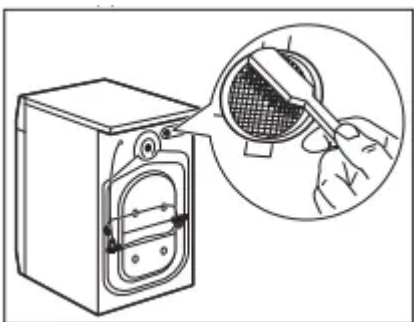

4. When you reconnect the hose to the back of the appliance, turn it left or right (not in vertical position) depending on the position of your water tap.

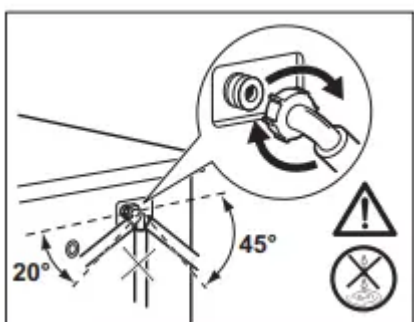

TROUBLESHOOTING

Introduction

The appliance does not start or it stops during operation.

First try to find a solution to the problem (refer to the table). If the problem persists, contact the Authorised Service Centre.

In case of major problems, the acoustic signals operate, the display shows an alarm code and the Start/Pause button may flash continuously:

- E11 - The appliance does not fill with water properly. Start the appliance again by pressing Start/Pause button. After 5 seconds the door will be unlocked.
- E21- The appliance does not drain the water.
- E41 - The appliance door is open or not closed correctly. Please check the door!

If the appliance is overloaded, remove some items from the drum and/or keep pressed the door while touching the Start/Pause button until the indicator  stops flashing (see the picture below).



- EH1 - Frequency of power supply out of range.
- EH2 - Supply voltage too high.
- EH3 - Supply voltage too low.
- E91 - Internal fail. Switch the appliance off and switch it on again. The programme was not finished properly or the appliance stopped too early. If the alarm code appears again, contact the Authorized Service Center and communicate it.
- EF3 - The anti-flood device is on. Disconnect the appliance and close the water tap. Contact the Authorised Service Centre.

Possible failures

The programme does not start.

- Make sure that the mains plug is connected to the mains socket.
- Make sure that the appliance door is closed.
- Make sure that there is no damaged fuse in the fuse box.
- Make sure that the Start/Pause has been touched.
- Make sure that the detergent dispenser is firmly closed.
- If the delay start is set, cancel the setting or wait for the end of countdown.
- Deactivate the Child Lock function if it is on.

The appliance does not fill with water properly.

- Make sure that the water tap is open.
- Make sure that the pressure of the water supply is not too low. For this information, contact your local water authority.
- Make sure that the water tap is not clogged.
- Make sure that the inlet hose has no kinks, damages or bends.
- Make sure that the connection of the water inlet hose is correct.

- Make sure that the filter of the inlet hose and the filter of the valve are not clogged. Refer to "Care and cleaning".

The appliance fills with water and drains immediately

- Make sure that the drain hose is in the correct position. The hose may be positioned too low. Refer to "Installation instruction".

The appliance does not drain the water.

- Make sure that the sink spigot is not clogged.
- Make sure that the drain hose has no kinks or bends.
- Make sure that the drain filter is not clogged. Clean the filter, if necessary. Refer to "Care and cleaning".
- Make sure that the connection of the drain hose is correct.
- Set the drain programme if you set a programme without drain phase.
- Set the drain programme if you set an option which ends with water in the tub.

The spin phase does not operate or the washing cycle lasts longer than usual.

- Set the spin programme.
- Make sure that the drain filter is not clogged. Clean the filter, if necessary. Refer to "Care and cleaning".
- Adjust manually the items in the tub and start the spin phase again. This problem may be caused by balance problems.

There is water on the floor.

- Make sure that the couplings of the water hoses are tight and there is not water leakages.
- Make sure that the water inlet hose and the drain hose have no damages.
- Make sure you use the correct detergent and the correct quantity of it.

You cannot open the appliance door.

- Make sure that a washing programme that ends with water in tub, has been selected.
- Make sure that the washing programme is finished.
- Set the drain or the spin programme if there is water in the drum.
- Make sure that the appliance receives electrical power.
- This problem may be caused by a failure of the appliance. Contact the Authorised Service Centre. If you need to open the door, please read carefully "Emergency door opening".
- Make sure that the Remote Start is not activated. Deactivate it.

The display does not show the wireless indicator .

- Check the wireless signal.
- Make sure that the wireless connection is on.
- Check your home network and router.
- Restart the router.
- Contact your wireless service provider if there are further problems with the wireless network

The App cannot connect to the appliance.

- Check the wireless signal.
- Check if your smart device is connected to the wireless network.
- Check your home network and router.
- Restart the router.
- Contact your wireless service provider if there are problems with the wireless network.
- The appliance, the smart device, or both, need to be configured again because a new router has been installed or the router configuration has been changed.

The App cannot frequently connect to the appliance.

- Make sure that the wireless signal reaches the appliance. Try to move the home router as near the appliance as possible or consider purchasing a wireless range extender.
- Make sure the wireless signal is not disrupted by microwave. Turn the microwave off. Avoid using the microwave and the remote control at the same time.

The appliance makes an unusual noise and vibrates.

- Make sure the levelling of the appliance is correct. Refer to "Installation instruction".
- Make sure that the packaging and/or the transit bolts are removed. Refer to "Installation instruction".
- Add more laundry in the drum. The load may be too small.

The programme duration increases or decreases during programme execution.

- The ProSense function is able to adjust the programme duration according to the type and the laundry load size. Refer to "The ProSense load detection" in "Daily Use" chapter.

The washing results are not satisfactory.

- Increase the detergent quantity or use a different detergent.
- Use special products to remove the stubborn stains before you wash the laundry.
- Make sure that you set the correct temperature.
- Decrease the laundry load.

- When using AutoDose tanks, make sure that they are not empty.
- When using AutoDose tanks, verify the pre-set detergent/ fabric softener dose. Refer to "AutoDose basic setting" paragraph in "The AutoDose Technology (Autodosing)" chapter.
- Make sure that you have cleaned the AutoDose tanks before using different brand and type of detergent, fabric softener or other additives.

Too much foam in the drum during the washing cycle.

- Reduce the quantity of detergent.
- When using AutoDose tanks, verify the pre-set detergent/ fabric softener dosage. Refer to "AutoDose basic setting" paragraph in "The AutoDose Technology (Autodosing)" chapter.

The detergent/fabric softener level does not decrease in the AutoDose tanks after washing.

- This is normal: tanks are quite large and detergent consumption may be not so evident.

After the check, activate the appliance. The programme continues from the point of interruption.

If the problem occurs again, contact the Authorised Service Centre.

If the display shows other alarm codes. Deactivate and activate the appliance. If the problem continues, contact the Authorised Service Centre.

Emergency door opening

In case of power failure or functioning failure the appliance door remains locked. The washing programme continues when the power is restored. If the door remains locked in case of failure, it is possible to open it using the emergency unlock function.

Before opening the door:

To open the door, proceed as follows:

1. Press the On/Off button to switch the appliance off.
2. Disconnect the mains plug from the mains socket.
3. Open the filter flap.
4. Pull the emergency unlock trigger downward once. Pull it downward once again, keep it tensed and, in the meanwhile, open the appliance door.
5. Take out the laundry and then close the appliance door.
6. Close the filter flap.



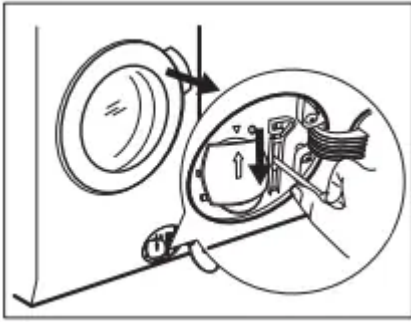

Warning

This content is compiled from multiple sources and is provided for reference purposes only. It may not be complete or fully applicable to all situations. If you are unable to resolve your issue, please contact the product manufacturer or an authorized service provider for official support.

Document generated by [ManualsFile](#)