

## About the controls with temperature settings.



*(on some models)*



*(on some models)*

NOTE: The refrigerator is shipped with protective film covering the digital temperature controls. If this film was not removed during installation, remove it now.

Initially, set the refrigerator control at 5 and the freezer control at 5. Allow 24 hours for the temperature to stabilize. Several adjustments may be required. Adjust the controls one increment at a time, and allow 24 hours after each adjustment for the refrigerator to reach the temperature you have set.

Setting either or both controls to 0 for digital and 0 for the refrigerator control knob stops cooling in both the refrigerator and freezer compartments, but does not shut off electrical power to the refrigerator.

## About the water filter. (on some models)

### Water Filter Cartridge

The water filter cartridge is located in the back upper right corner of the refrigerator compartment.



### When to Replace the Filter

The filter cartridge should be replaced when the flow of water to the icemaker decreases, or every six months.

## Installing the Filter Cartridge



1. If you are replacing the cartridge, first remove the old one. Open the cartridge cover by pressing in on the tab at the front and pulling down.



2. Remove the cartridge by slowly rotating it counterclockwise. A small amount of water may drip down.

**CAUTION** If air has been trapped in the system, the filter cartridge may be ejected as it is removed. Use caution when removing.

3. Remove the protective foil from the end of the cartridge.

4. Lining up the arrow on the cartridge and the cartridge holder, slowly rotate the cartridge clockwise until it stops. When the cartridge is properly installed, you will feel it “click” as it locks into place. The grip on the end of the cartridge should be positioned vertically. Do not overtighten.



5. Close the cartridge cover.

## Filter Bypass Plug

You must use the filter bypass plug when a replacement filter cartridge is not available. The icemaker will not operate without the filter or filter bypass plug.

**Replacement Filters:** To order additional filter cartridges in the United States, visit our Website, [GEAppliances.com](http://GEAppliances.com), or call GE Appliances Parts and Accessories, 800.626.2002.

Filter Model GSWF: Customers in Canada should consult the yellow pages for the nearest Mabe Service Center.

## About the shelves and bins.

Not all features are on all models.

### Rearranging the Shelves

Shelves in the refrigerator compartment are adjustable.

#### Refrigerator Compartment



*Some models have wire shelves that can be adjusted in the same manner.*

#### To remove:

1. Remove all items from the shelf.
2. Tilt the shelf up at the front.
3. Lift the shelf up at the back and bring the shelf out.



#### To replace:

1. While tilting the shelf up, insert the top hook at the back of the shelf in a slot on the track.
2. Lower the front of the shelf until the bottom of the shelf locks into place.

#### Non-Adjustable Shelves on the Door (on some models)



**To remove:** Lift the shelf straight up; then pull out.

**To replace:** Engage the shelf in the molded supports on the door and push down.

It will lock in place.

## About the crispers and pans.

Not all features are on all models.

### Fruit and Vegetable Crisper

Excess water that may accumulate in the bottom of the drawers or under the drawers should be wiped dry.



### Adjustable Humidity Crisper (on some models)



Slide the control all the way to the HIGH setting to provide high humidity recommended for most vegetables.

Slide the control all the way to the LOW setting to provide lower humidity levels recommended for most fruits.

### Snack Pan (on some models)



This pan can be moved to the most useful location for your family's needs.

To remove, slide the pan out to the stop position, lift the pan up and past the stop position and lift it out.

## About the freezer drawer. (on some models)

Not all features are on all models.

### Freezer Shelves and Baskets



*Appearance and features may vary*

1. A shelf above the ice storage bin
2. A half-width basket
3. A deep full-width basket

**NOTE:** Do not fill baskets higher than the rim of the basket. This may cause baskets to stick or jam when opening or closing

### Basket Removal

**To remove the deep full-width basket on freezer drawer models:**

1. Open the freezer drawer until it stops.
2. The freezer basket rests on the inside tabs on the drawer slides.
3. Lift the basket so that it is out of all 6 slide bracket tabs.
4. Tilt the basket and lift out of the drawer.

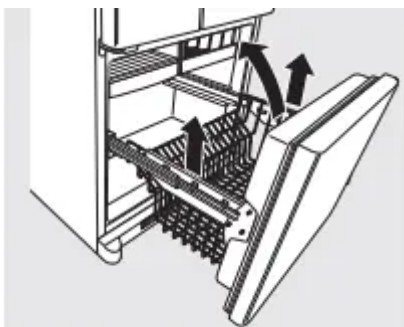

*Appearance may vary*

When replacing the deep full-width basket: Tilt the basket back and lower it down into the drawer. Rotate the basket to a horizontal position and press it down into the 6 alignment tabs.

**NOTE:** Always be sure that the basket is seated in all 6 slide bracket tabs before sliding back into the freezer. The basket can be turned in either direction front to back and installed into the freezer.

**To remove the half-width basket:**



*Appearance may vary*

1. Pull the basket out to the stop location.
2. Lift the basket up at the front to release it from the stop hooks on each side.
3. Lift the basket out to remove it from the sides.

When replacing the basket, make sure that the basket goes under the stop hooks on each side.

**NOTE:** Always be sure to fully close this basket.

## About the freezer compartment. (on some models)

Not all features are on all models.

### Freezer Shelf and Basket



1. A full-width fixed wire shelf
2. A full-width sliding wire basket

NOTE: Do not fill basket higher than the rim of the basket. This may cause basket to stick or jam when opening or closing

### Basket Removal

To remove the full-width sliding wire basket on door models:

1. Open the basket out to its full extension.
2. Lift up the front of the basket and pull straight out to remove.



**When replacing the full-width sliding wire basket:** Insert the wire basket into the lower liner's rails and push back into place.

### Fixed Shelf Removal



**NOTE:** The full-width wire shelf is not intended to slide.

**To remove for cleaning:** Hold the shelf at the front and pull it firmly forward.

**When replacing the full-width sliding wire shelf:** Insert the wire shelf into the upper liner's rails and push back into place.

### Non-Adjustable Shelf on Freezer Door



*To remove*

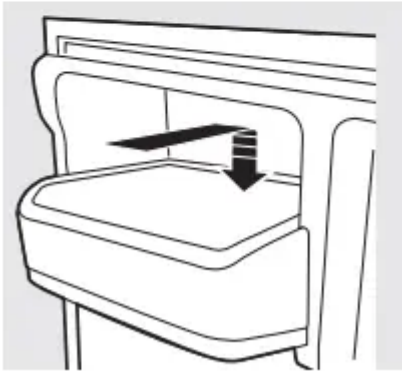

*To replace*

To remove: Lift the shelf straight up; then pull out.

To replace: Engage the shelf in the molded supports on the door and push down. It will lock in place.

## About the automatic icemaker. (on some models)

A newly installed refrigerator may take 12 to 24 hours to begin making ice.

### Automatic Icemaker



The icemaker will produce seven cubes per cycle—approximately 100–130 cubes in a 24-hour period, depending on freezer compartment temperature, room temperature, number of door openings and other use conditions.

See below for how to access ice and reach the power switch.

If the refrigerator is operated before the water connection is made to the icemaker, set the power switch in the O (off) position.

When the refrigerator has been connected to the water supply, set the power switch to the I (on) position. The icemaker power light will turn green when the freezer light switch is pressed in or when the freezer door is closed.

The icemaker will fill with water when it cools to 15°F (–10°C). A newly installed refrigerator may take 12 to 24 hours to begin making ice cubes.

You will hear a buzzing sound each time the icemaker fills with water.

Throw away the first few batches of ice to allow the water line to clear.

Be sure nothing interferes with the sweep of the feeler arm.

When the bin fills to the level of the feeler arm, the icemaker will stop producing ice. It is normal for several cubes to be joined together.

If ice is not used frequently, old ice cubes will become cloudy, taste stale and shrink.

**NOTE:** In homes with lower-than-average water pressure, you may hear the icemaker cycle multiple times when making one batch of ice.

**NOTE:** Set the power switch to the O (off) position if the water supply is shut off.

**CAUTION** Avoid contact with the moving parts of the ejector mechanism, or with the heating element (located on the bottom of the ice maker) that releases the cubes. Do not place fingers or hands on the automatic ice making mechanism while the refrigerator is plugged in.

### Accessing Ice and Reaching the Power Switch

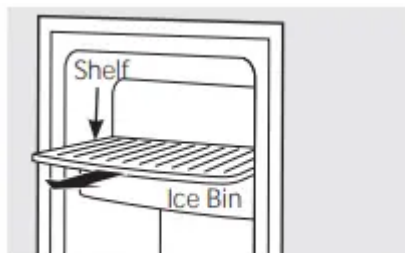

*To reach the power switch.*

To reach the icemaker power switch, pull the shelf above the ice bin straight out. Always be sure to replace the shelf.

To access ice, simply pull the bin forward.



*To access ice.*

### **Icemaker Accessory Kit**

If your refrigerator did not come already equipped with an automatic icemaker, an icemaker accessory kit is available at extra cost.

Check the back of the refrigerator for the specific icemaker kit needed for your model.

## **Care and cleaning of the refrigerator.**

### **Cleaning the Outside**

**The door handles and trim.** Clean with a cloth dampened with soapy water. Dry with a soft cloth. Do not use wax on the door handles and trim.

**Keep the outside clean.** Wipe with a clean cloth lightly dampened with kitchen appliance wax or mild liquid dish detergent. Dry and polish with a clean, soft cloth.

*Do not wipe the refrigerator with a soiled dish cloth or wet towel. These may leave a residue that can erode the paint. Do not use scouring pads, powdered cleaners, bleach or cleaners containing bleach because these products can scratch and weaken the paint finish.*

**The stainless steel panels and door handles.** The stainless steel doors and door handles (on some models) can be cleaned with a commercially available stainless steel cleaner. Cleaners with oxalic acid such as Bar Keepers Friend Soft Cleanser™ will remove rust, tarnish and small blemishes. Use only a liquid cleanser free of grit and rub in the direction of the brush lines with a damp soft sponge.

Do not use appliance wax or polish on the stainless steel.

### **Cleaning the Inside**

**To help prevent odors,** leave an open box of baking soda in the refrigerator and freezer compartments.

**Unplug the refrigerator before cleaning.** If this is not practical, wring excess moisture out of sponge or cloth when cleaning around switches, lights or controls.

Use an appliance wax polish on the inside surface between the doors.

Use warm water and baking soda solution about a tablespoon (15 ml) of baking soda to a quart (1 liter) of water. This both cleans and neutralizes odors. Rinse and wipe dry.

After cleaning the door gaskets, apply a thin layer of petroleum jelly to the door gaskets at the hinge side. This helps keep the gaskets from sticking and bending out of shape.

**CAUTION:** Do not clean glass shelves or covers with warm water when they are cold. Glass shelves and covers may break if exposed to sudden temperature changes or impact such as bumping or dropping. Tempered glass is designed to shatter into many small pieces if it breaks. Do not wash any plastic refrigerator parts in the dishwasher.

### **Behind the Refrigerator**

Be careful when moving the refrigerator away from the wall. All types of floor coverings can be damaged, particularly cushioned coverings and those with embossed surfaces.

Raise the leveling legs located at the bottom front of the refrigerator.

Pull the refrigerator straight out and return it to position by pushing it straight in. Moving the refrigerator in a side direction may result in damage to the floor covering or refrigerator.

Lower the leveling legs until they touch the floor.

*When pushing the refrigerator back, make sure you don't roll over the power cord or icemaker supply line (on some models)*

### **Preparing for Vacation**

For long vacations or absences, remove food and unplug the refrigerator. Clean the interior with a baking soda solution of one tablespoon (15 ml) of baking soda to one quart (1 liter) of water. Leave the doors open.

Set the icemaker power switch to the O (off) position and shut off the water supply to the refrigerator.

If the temperature can drop below freezing, have a qualified servicer drain the water supply system (on some models) to prevent serious property damage due to flooding.

### **Preparing to Move**

Secure all loose items such as base grille, shelves and drawers by taping them securely in place to prevent damage.

When using a hand truck to move the refrigerator, do not rest the front or back of the refrigerator against the hand truck. This could damage the refrigerator. Handle only from the sides of the refrigerator.

*Be sure the refrigerator stays in an upright position during moving.*

## **Replacing the light bulbs.**

**WARNING** Before replacing a burned-out light bulb, the refrigerator should be unplugged in order to avoid contact with a live wire filament. (A burned-out light bulb may break when being replaced.)

Turning the control to the OFF position does not remove power to the light circuit.

## Refrigerator Lights



1. Unplug the refrigerator.
2. To remove the light shield, grasp the shield at the back and pull out to release the tabs at the back.
3. Rotate the shield down and then forward to release the tabs at the front of the shield.
4. After replacing with an appliance bulb of the same or lower wattage, replace the shield.
5. Plug the refrigerator back in.

**NOTE:** Appliance bulbs may be ordered from GE Appliance Parts and Accessories, 800.626.2002.

## Freezer Light



*Appearance may vary*

1. Unplug the refrigerator.
2. The bulb is located at the top of the freezer inside a light shield. To remove the shield, grasp the shield at the back and pull out to release the tabs at the back.
3. Rotate the shield down and then forward to release the tabs at the front of the shield.
4. After replacing with an appliance bulb of the same or lower wattage, replace the shield.
5. Plug the refrigerator back in.

## Normal operating sounds.

Newer refrigerators sound different from older refrigerators. Modern refrigerators have more features and use newer technology.

Do you hear what I hear? These sounds are normal.

## **HUMMM... WHOOSH...**

- The new high efficiency compressor may run faster and longer than your old refrigerator and you may hear a high-pitched hum or pulsating sound while it is operating.
- You may hear a whooshing sound when the doors close. This is due to pressure equalizing within the refrigerator.



- You may hear the fans spinning at high speeds. This happens when the refrigerator is first plugged in, when the doors are opened frequently or when a large amount of food is added to the refrigerator or freezer compartments. The fans are helping to maintain the correct temperatures.
- The fans change speeds in order to provide optimal cooling and energy savings.

## **CLICKS, POPS, CRACKS and SNAPS**

- You may hear cracking or popping sounds when the refrigerator is first plugged in. This happens as the refrigerator cools to the correct temperature.
- The freezer control will click when starting or stopping the compressor.
- Defrost timer snapping in and out of the defrost cycle.
- Expansion and contraction of cooling coils during and after defrost can cause a cracking or popping sound.
- On models with an icemaker, after an icemaking cycle, you may hear the ice cubes dropping into the ice bucket.
- On models with a dispenser, during water dispense, you may hear the water lines move at initial dispense and after dispenser button is released.

## **WATER SOUNDS**



- The flow of refrigerant through the freezer cooling coils may make a gurgling noise like boiling water.
- Water dropping on the defrost heater can cause a sizzling, popping or buzzing sound during the defrost cycle.
- A water dripping noise may occur during the defrost cycle as ice melts from the evaporator and flows into the drain pan.
- Closing the door may cause a gurgling sound due to pressure equalization.

## **Before you call for service...**

### Troubleshooting Tips

Save time and money! Review the charts on the following pages first and you may not need to call for service.



<b>Problem</b>	<b>Possible Causes</b>	<b>What To Do</b>
Refrigerator does not operate	Refrigerator in defrost cycle.	• Wait about 30 minutes for defrost cycle to end.
	Control in Off position.	• Move the control to a temperature setting.
	Refrigerator is unplugged.	• Push the plug completely into the outlet.
	The fuse is blown/circuit breaker is tripped.	• Replace fuse or reset the breaker.
Vibration or rattling (slight vibration is normal)	Leveling legs need adjusting.	• See Level the Refrigerator.
Motor operates for long periods or cycles on and off frequently. (Modern refrigerators with more storage space and a larger freezer require more operating time. They start and stop often to maintain even temperatures.)	Normal when refrigerator is first plugged in.	• Wait 24 hours for the refrigerator to completely cool down.
	Often occurs when large amounts of food are placed in refrigerator.	• This is normal.
	Door left open.	• Check to see if package is holding door open.
	Hot weather or frequent door openings.	• This is normal.
Refrigerator or freezer compartment too warm	Temperature control set at the coldest setting.	• See About the controls.
	Temperature controls not set cold enough.	• See About the controls.
	Warm weather or frequent door openings.	• Set the temperature control one step colder. See About the controls.
	Door left open.	• Check to see if package is holding door open.
	Door left open.	

Frost or ice crystals on frozen food (frost within package is normal)		<ul style="list-style-type: none"> <li>• Check to see if package is holding door open.</li> </ul>
	Door openings too frequent or too long.	<ul style="list-style-type: none"> <li>• This is normal.</li> </ul>
Frequent “buzzing” sound	Icemaker power switch is in the I (on) position, but the water supply to the refrigerator has not been connected.	<ul style="list-style-type: none"> <li>• Set the power switch to the 0 (off) position. Keeping it in the I (on) position will damage the water valve.</li> </ul>
Small or hollow cubes	Water filter clogged.	<ul style="list-style-type: none"> <li>• Replace filter cartridge with new cartridge or with plug.</li> </ul>
Automatic icemaker (on some models) does not work	Icemaker power switch is not on.	<ul style="list-style-type: none"> <li>• Set the power switch to the I (on) position. The icemaker power light will turn green when the freezer light switch is does not work pressed in or when the freezer door is closed.</li> </ul>
	Water supply turned off or not connected.	<ul style="list-style-type: none"> <li>• See Installing the water line.</li> </ul>
	Freezer compartment too warm.	<ul style="list-style-type: none"> <li>• Wait 24 hours for the refrigerator to completely cool down.</li> </ul>
	Piled up cubes in the storage bin cause the icemaker to shut off.	<ul style="list-style-type: none"> <li>• Level cubes by hand.</li> </ul>
	Ice cubes stuck in icemaker. (Green power light on icemaker blinking.)	<ul style="list-style-type: none"> <li>• Turn off the icemaker, remove cubes and turn the icemaker back on.</li> </ul>
	Icemaker light is not lit.	<ul style="list-style-type: none"> <li>• This is normal when the freezer door is open. The icemaker power light will turn green when the freezer light switch is pressed in or when the freezer door is closed.</li> </ul>

Ice cubes have odor/taste	Food transmitting odor/taste to ice cubes.	<ul style="list-style-type: none"> <li>• Wrap foods well.</li> </ul>
	Interior of refrigerator needs cleaning.	<ul style="list-style-type: none"> <li>• See Care and cleaning.</li> <li>• Keep an open box of baking soda in the refrigerator; replace every three months.</li> </ul>
Slow ice cube freezing	Door left open.	<ul style="list-style-type: none"> <li>• Check to see if package is holding door open.</li> </ul>
	Freezer control not set cold enough.	<ul style="list-style-type: none"> <li>• See About the controls.</li> </ul>
Refrigerator has odor	Foods transmitting odor to refrigerator.	<ul style="list-style-type: none"> <li>• Foods with strong odors should be tightly wrapped.</li> <li>• Keep an open box of baking soda in the refrigerator; replace every three months.</li> </ul>
	Interior needs cleaning.	<ul style="list-style-type: none"> <li>• See Care and cleaning.</li> </ul>
Moisture forms on outside of refrigerator	Not unusual during periods of high humidity.	<ul style="list-style-type: none"> <li>• Wipe surface dry and reset the refrigerator control one setting colder.</li> </ul>
Moisture collects inside (in humid weather, air carries moisture into refrigerator when doors are opened)	Too frequent or too long door openings.	<ul style="list-style-type: none"> <li>• This is normal.</li> </ul>
Refrigerator or freezer compartment light does not work	No power at outlet.	<ul style="list-style-type: none"> <li>• Replace fuse or reset the breaker.</li> </ul>
	Light bulb burned out or loose.	<ul style="list-style-type: none"> <li>• See Replacing the light bulbs.</li> </ul>
Door/drawer does not close by itself	Leveling legs need adjusting.	<ul style="list-style-type: none"> <li>• See Installing the Refrigerator.</li> </ul>
Freezer door/drawer pops open when refrigerator door is closed	This is normal if, after popping open, the freezer	<ul style="list-style-type: none"> <li>• This indicates that there is a good seal on the freezer door/drawer. If the freezer door/</li> </ul>

	door/drawer closed on its own.	drawer does not automatically close after popping open, then see the Problem: Door/drawer does not close by itself, above.
Hot air from bottom of refrigerator	Normal air flow cooling motor. In the refrigeration process, it is normal that heat be expelled in the area under the refrigerator. Some floor coverings will discolor at these normal and safe temperatures.	
Food freezing in the refrigerator	Food too close to the air vent at the back of the refrigerator.	<ul style="list-style-type: none"> <li>• Move the food away from the air vent.</li> </ul>
	Refrigerator control is set too cold.	<ul style="list-style-type: none"> <li>• Move the refrigerator control to a warmer temperature setting one increment at a time.</li> </ul>
Orange glow in the freezer	Defrost heater is on.	<ul style="list-style-type: none"> <li>• This is normal.</li> </ul>
No ice cube production (on some models)	Supply line or shutoff valve is clogged.	<ul style="list-style-type: none"> <li>• Call a plumber.</li> </ul>
	Water filter clogged.	<ul style="list-style-type: none"> <li>• Replace filter cartridge or remove filter and install plug.</li> </ul>
	Filter cartridge not properly installed.	<ul style="list-style-type: none"> <li>• Remove and reinstall filter cartridge, being certain that it locks into place. The blade on the end of the cartridge should be positioned vertically.</li> </ul>
Handle is loose / handle has a gap	Handle needs adjusting.	<ul style="list-style-type: none"> <li>• See Attach the Fresh Food Door Handle and Attach the Freezer Door Handle sections for detailed instructions.</li> </ul>
Refrigerator beeping	This is the door alarm.	<ul style="list-style-type: none"> <li>• Close door.</li> </ul>

Control setting is not lit	On some models, the light bulbs at the top of the refrigerator compartment light up the temperature control settings.	<ul style="list-style-type: none"> <li>• If the control settings do not light up, check to see if the light bulbs are burned out, and replace if necessary.</li> </ul>
Refrigerator doors are not even (on Double Door models only)	Doors need realigning.	<ul style="list-style-type: none"> <li>• See Align Double Doors section located under Replacing the Door (Double Door Refrigerator Models only).</li> </ul>
Baskets stick or jam when opening or closing	Baskets are too full.	<ul style="list-style-type: none"> <li>• To open: remove some of the products from the basket when opened as far as possible. Readjust the products left in the basket and try to open the basket again.</li> <li>• To close: readjust products in the basket or remove any product that is above the rim of the basket and close the basket.</li> </ul>

**Warning**

This content is compiled from multiple sources and is provided for reference purposes only. It may not be complete or fully applicable to all situations. If you are unable to resolve your issue, please contact the product manufacturer or an authorized service provider for official support.

