

HOW TO SAVE ENERGY



Using energy in a responsible way not only saves money but also helps the environment. So let us save energy! And this is how you can do it:

! Do not uncover the pan too often(a watched pot never boils!)

Do not open the oven door unnecessarily often.

! Switch off the oven in good time and make use of residual heat.

For long cooking times, switch off heating zones 5 to 10 minutes before finishing cooking, This saves up to 20% on energy.

Only use the oven when cooking larger dishes.

Meat of up to 1 kg can be prepared more economically in a pan on the cooker hob.

! Make use of residual heat from the oven.

If the cooking time is greater than 40 minutes switch off the oven 10 minutes before the end time.

Important! When using the timer, set appropriately shorter cooking times according to the dish being prepared.

! Make sure the oven door is properly closed.

Heat can leak through spillages on the door seals. Clean up any spillages immediately.

! Do not install the cooker in the direct vicinity of refrigerators/freezers.

Otherwise energy consumption increases unnecessarily



Baking tray X1



Grill grate (drying rack)X1



Rotisserie

INSTALLATION

! The kitchen area should be dry and aired and equipped with efficient ventilation. When installing the oven, easy access to all control elements should be ensured.

! This is a built-in oven, and its back wall and one side wall can be placed next to a high piece of furniture or a wall. Coating or veneer used on fitted furniture must be applied with a heat-resistant adhesive (215°F). This prevents surface deformation or detachment of the coating.

! Make an opening with the dimensions given in the diagram for the oven to be fitted.

! Make sure the mains plug is disconnected and then connect the oven to the mains supply.

! Insert the oven completely into the opening without allowing the four screws in the places shown in the diagram to fall out.

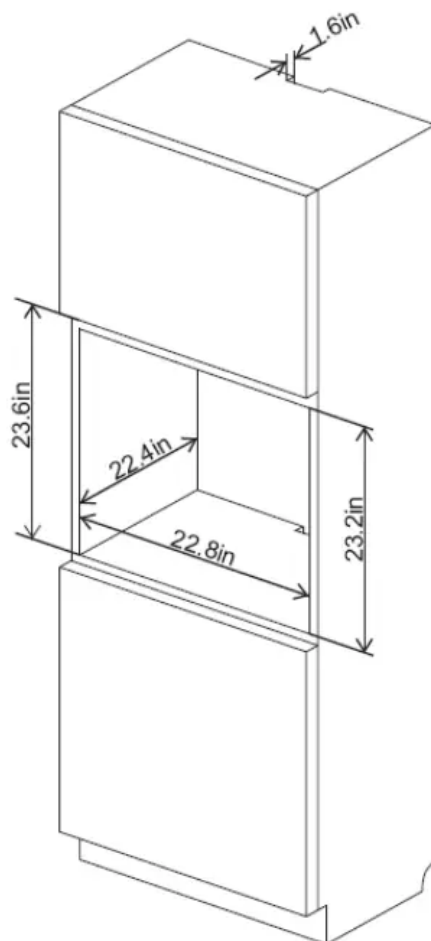

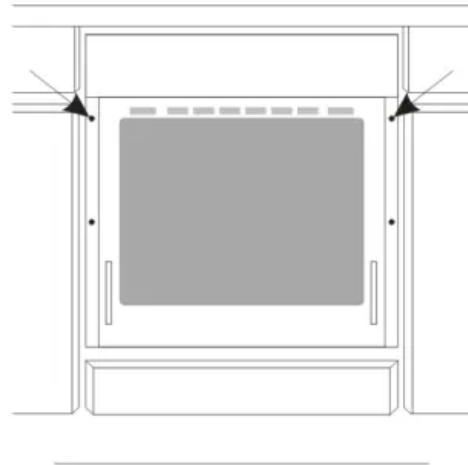
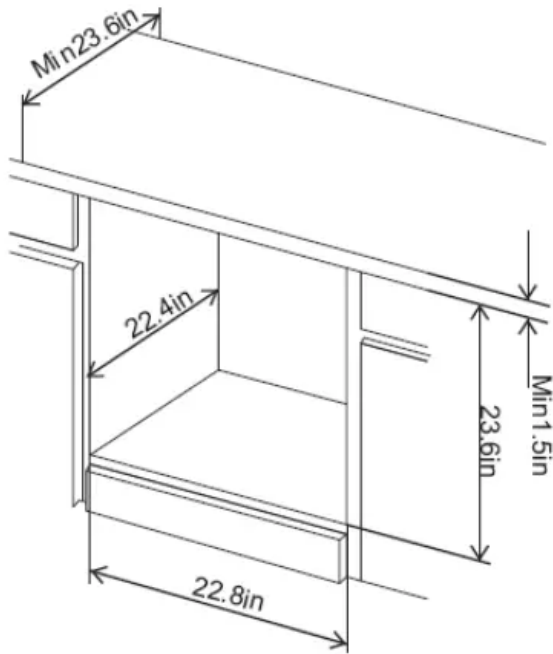

MAKE ELECTRICAL CONNECTION

⚠ WARNING



Electrical Shock Hazard

Disconnect power before servicing.

Use 8 gauge solid copper wire.

Electrically ground oven.

Failure to follow these instructions can result in death, fire, or electrical shock.

This oven is manufactured with a neutral (white) power supply wire and a cabinet-connected green(or bare)ground wire twisted together.

1. Disconnect power.
2. Feed the flexible conduit from the through the opening in the cabinet.
3. Remove junction box cover, if it is present.

4. Install a UL listed or CSA approved conduit connector to the junction box.

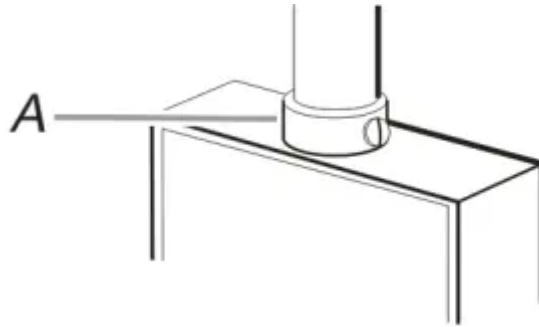

5. Route the flexible conduit from the oven to the junction box through a UL listed or CSA approved conduit connector.

6. Tighten screens on conduit connection.

7. See “Electrical Connection Options “to complete installation for your type of electrical connection.

MAKE ELECTRICAL CONNECTION

Electrical Connection Options Chart

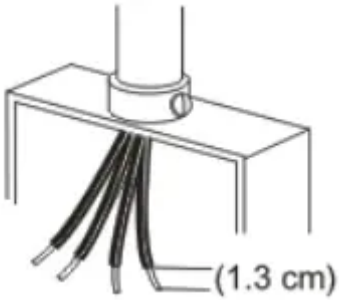
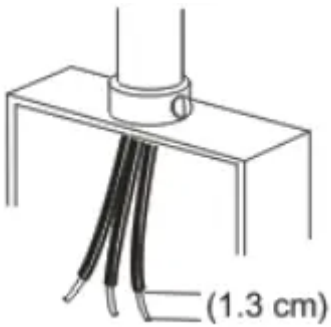
If your home has :	Go to section:
<p>4-wire</p> 	<p>4-wire cable from home power supply</p>
<p>3-wire</p> 	<p>3-wire cable from home power supply</p>

4-Wire Cable from Home Power Supply

IMPORTANT: Use the 4-wire cable from home power supply in the U.S. where local codes do not allow grounding through neutral. New Branch circuit installations (1996 NEC), mobile homes and recreational vehicles, new construction and in Canada.

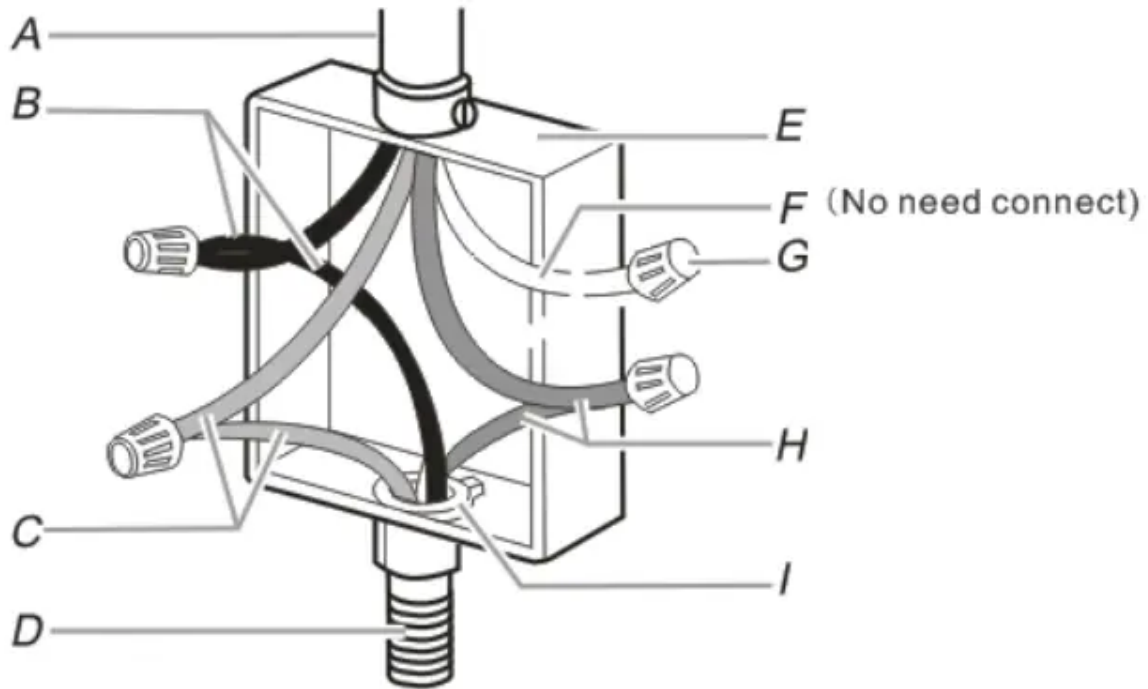

- A. Cable from home power supply
- B. Black wires
- C. Red wire
- D. 3-wire flexible conduit from oven
- E. Junction box
- F. White wires (No need connect)
- G. UL listed wire connectors
- H. Green (or bare) ground wires
- I. UL listed or CSA approved conduit connector

1. Connect the 2 black wires (B) together using a UL listed wire connector.
2. Connect red wire (C) together using a UL listed wire connector.
3. No need connect (F) with any wire, just with UL list wire connector.
4. Connect the green (or bare) ground wire (H) from the oven cable to the green (or bare) ground wire (in the junction box) using a UL listed wire connector.
5. Install junction box cover.

3-Wire Cable from Home Power Supply - U.S. Only

IMPORTANT: Use the 3-wire cable from home power supply where local codes permit a 3-wire connection.

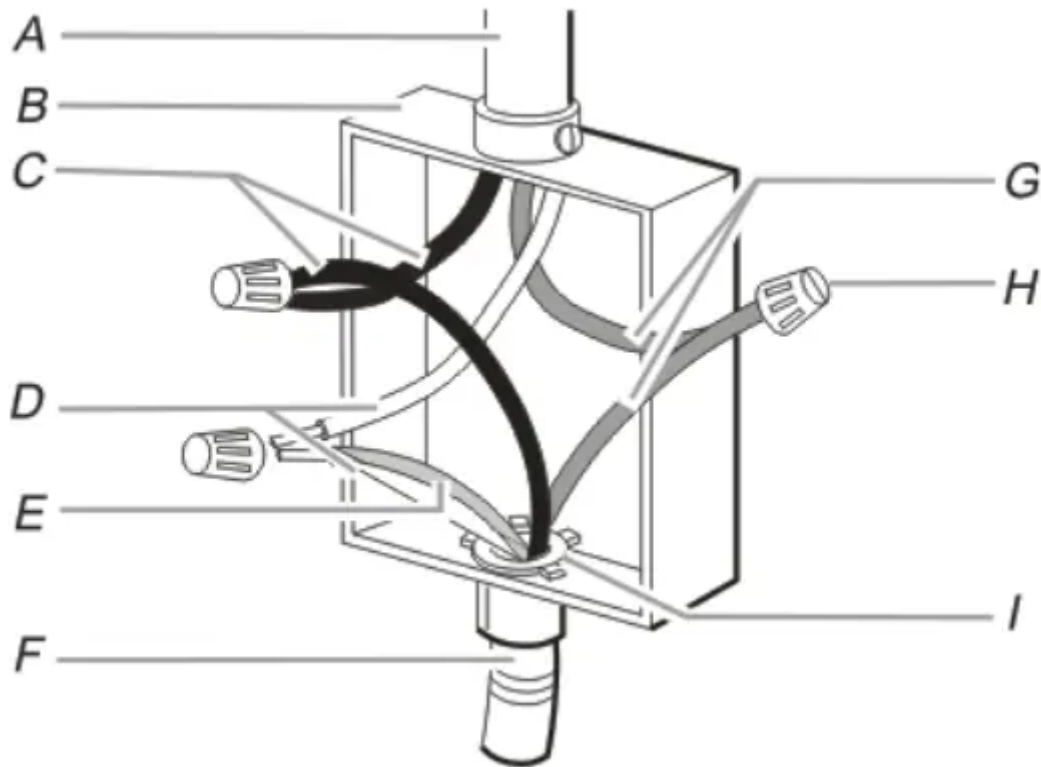

- A. Cable from home power supply
- B. Junction box
- C. Black wires
- D. White wire from home
- E. Green(or bare) ground wire (from oven)
- F. 3-wire flexible conduit from oven
- G. Red wire
- H. UL list wire connectors
- I. UL listed or CSA approved conduit connector

1. Connect the two black wires (C) together using a UL listed wire connector.
2. Connect the white wires from home (D) and the green (or bare) ground wire (of the oven cable) (E) using a UL listed wire connector.
3. Connect red wire (G) together using a UL listed wire connector.
4. Install junction box cover

Before first use

Remove packaging, clean the interior of the oven and the hob.

Take out and wash the oven fittings with warm water and a little washing-up liquid.

Switch on the ventilation in the room or open a window.

Heat the oven (to a temperature of 465°F, for approx., 30 min.), remove any stains and wash carefully; the heating zones of the hob should be heated for around 4 min. without a pan.

Important!



The inside of the oven should only be washed with warm water and a small amount of washing-up liquid.

OPERATION

LED display



1. Turn On and off

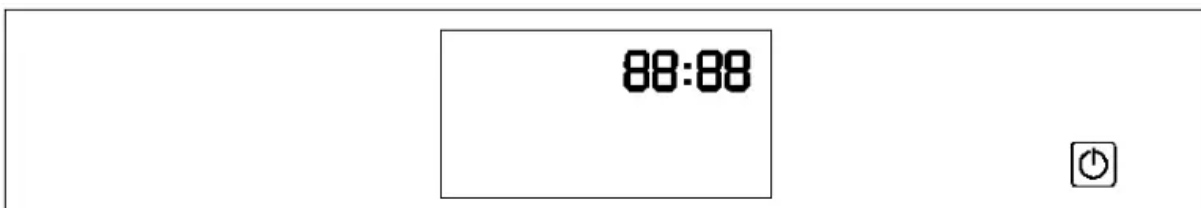

- Turn on: when the product is off, touch  , it is in standby status.
- Turn off: In working status, touch  , it is off.

The LED displays below when in standby:





Note: when it is set up electricity, if the clock is not set up, it will not show time and only shows (0:00)

2. Set up clock (24 hours):

- (1) In standby condition, touch  once, hour flicker, reminding to set up.
- (2) Touch  or  keys, set up hours (0-23), defaulted "00"



- (3) Touch  once again; finish hour set up, the minute flicker, reminding to set up.
- (4) Touch  or  keys, set up minutes (0-59). Defaulted "00".



- (5) Touch  key once, clock setup finish, start to work. The ":" flicker once each second. (Example: 12:30)

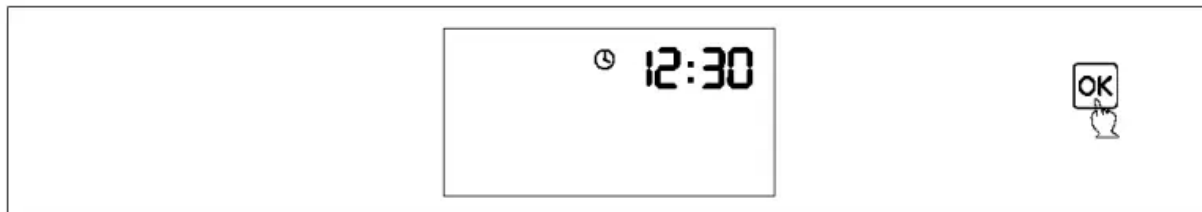





3. Function selection: "Roast" as example (other functions are same way to set)





- (1) In standby condition, touch "Roast" continuously, display shows as below diagram ("XX" means flicker, others are bright).



- (2) After function selection, can set up temperature and working time as below:

a. Touch  or  touch one, the temperature can increase (or decrease) 40°F, temperature can be set between 104°F and 446°F.

b. Touch  once, the hour flicker, touch  or  keys, can set time between 0 and 9 hours.

c. Touch  once again (or touch twice continuously), minute flicker and touch  or  key, it can set up minutes between 0 and 59 minutes, touch  key, it will start to work, other icon will not show.

For example: Working time set as 1:30 hours, temperate set as 410°F..



d. Under condition of item 3-(1) or item 3-(2) , touch  key, it will work as system defaulted or current condition.

Table 1(With rotisserie)























Icon										
Working mode	Roast	Preheat	Conv Bake	Conv Broil	Broil	Conv Roast	True Conv Roast	Bake	Rotisserie	Defrost
Default temperature	410°F	410°F	428°F	410°F	410°F	410°F	446°F	140°F	410°F	
Temperature can be set	104-446°F	104-446°F	104-446°F	104-446°F	104-446°F	104-446°F	104-446°F	104-356°F	104-446°F	
Time can be set	0:01-9:00									

Table 2(Without rotisserie)





Icon									
Working mode	Roast	Preheat	Conv Bake	Conv Broil	Broil	Conv Roast	True Conv Roast	Bake	Defrost
Default temperature	410°F	410°F	428°F	410°F	410°F	410°F	446°F	140°F	
Temperature can be set	104-446°F	104-446°F	104-446°F	104-446°F	104-446°F	104-446°F	104-446°F	104-356°F	
Time can be set	0:01-9:00								

4. Checking function







-  (1) In working condition, touch  key, can check current time, flicker 5 times it will turn to original working condition automatically.

- (2) In working condition, touch  key, can check the time set up, flicker 5 times it will turn to original working condition automatically.

5. Set up child lock

- (1) Lock: Touch  key once,  icon shows in LED, it is locked, and there is no function to touch any other keys.
- (2) Unlock: Touch  key again,  icon does not show, and then it is unlocked.
Maybe touch  more than 4 seconds to turn off all functions.

6. Delay function

- (1) Touch  once, the hour flicker, touch  or  keys, can set time between 0 and 23 hours. Touch  again, minute flicker and touch  or  key, it can set up minutes between 0 and 59 minutes, touch  key, delay setup finish. Flicker 3 times it will turn to working time, and flicker 3 times again, it will turn to clock.

CLEANING AND MAINTENANCE

By ensuring proper cleaning and maintenance of your cooker, you can have a significant influence on the continuing fault-free operation of your appliance.

Before you start cleaning, the cooker must be switched off and you should ensure that all knobs are set to the "OFF" position.

Do not start cleaning until the cooker has completely cooled.

Caution! The sharp blade should always be protected by adjusting the cover (just push it with your thumb). Injuries are possible so be careful when using this instrument-keep out of reach of children

- Appropriate light cleaning or washing products are recommended, such as e.g. any kind of liquids or emulsions for fat removal. In particular, special cleaning products such as COLLO Luneta, Sidol Stahlglanz, Stahl-Fix for washing and Cleaning and Cera Fix for maintenance are recommended. If the recommended products are not available, it is advisable to use a solution of warm water with a little washing-up liquid or cleaning products for stainless steel sinks.

Oven

- The oven should be cleaned after every use. When cleaning the oven the lighting should be switched on to, enable you to see the surfaces better.
- The oven chamber should only be washed With warm water and small amount of washing-up liquid.
- After cleaning the oven chamber wipe it dry.

Caution!

Do not use cleaning products containing abrasive materials for the cleaning and maintenance of the glass front panel steam cleaning * :

pour 250ml of water(1 glass)into a bowl placed in the oven on the first level from the bottom

close the oven door,

set the temperature knob to 125°F,and the function knob to the bottom heater position

heat the oven chamber for approximately30 minutes

open the oven door, wipe the chamber inside with a cloth or sponge and wash using warm water with washing-up liquid.

Caution! Possible moisture or water residues under the cooker can result from steam cleaning

- After cleaning the oven chamber wipe it dry

Replacement of the oven light bulb

In order to avoid the possibility of an electric shock ensure that the appliance is switched off before replacing the bulb

- Set all control knobs to the position“OFF”/ “STOP” and disconnect the mains plug
- unscrew and wash the lamp cover and then wipe it dry
- unscrew the light bulb from the socket replace the bulb with a new one-a high temperature bulb (575 °F) with the following parameters:

-voltage 220~240 V~

-power 15 W

-thread E14

- Screw the bulb in, making sure it is properly Inserted into the ceramic socket
- Screw in the lamp cover.

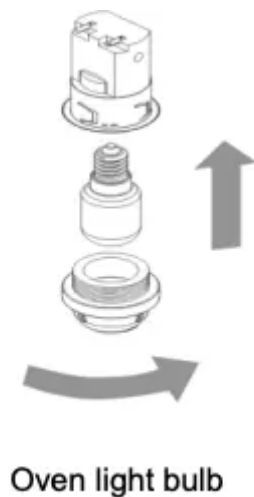

Door removal

In order to obtain easier access to the oven chamber for cleaning, it is possible to remove the door. To do this, tilt the safety catch part of the hinge upwards. Close the door lightly, lift and pull it out towards you. In order to fit the door back on to the cooker, do the inverse. When fitting, ensure that the notch of the Hinge is correctly placed on the protrusion of the hinge holder. After the door is fitted to the oven, the safety catch should be carefully lowered down again. If the safety catch is not set it may cause damage to the hinge when closing the door.

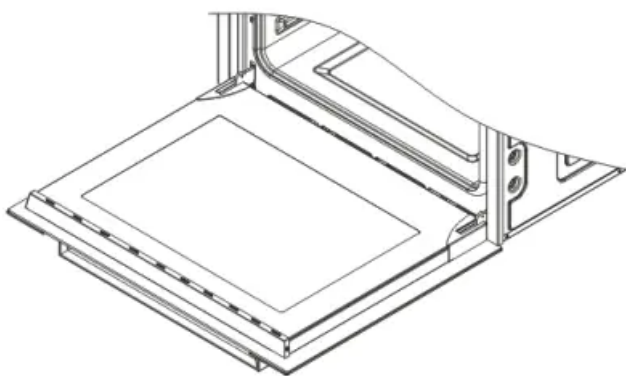

Door removal

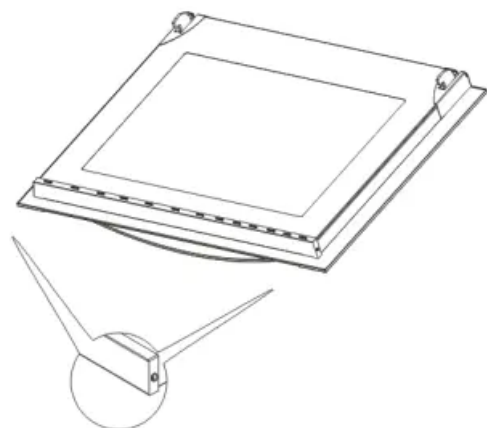

Removal of the internal glass panel

Removal of the internal glass panel

Unscrew and unfasten the plastic latch that is in the corner at the top of the door. Next take out the glass from the second blocking mechanism and remove. After cleaning, insert and block the glass panel, and screw in the blocking mechanism.

OPERATION IN CASE OF EMERGENCY

In the event of an emergency, you should:

- switch off all working units of the cooker

- disconnect the mains plug
- call the service center
- Some minor faults can be fixed by referring to the instructions given in the table below. Before calling the customer support center or the service center check the following points that are presented in the table.

Problem	Reason	Action
The appliance does not work.	break in power supply	check the household fuse box. if there is a blown fuse replace it with a new one
The oven lighting does not work	the bulb is loose or damaged	tighten up or replace the blown bulb (see chapter Cleaning and Maintenance)

About circuit protection issue :

1.Sensor protection : when sensor is not connected or turnoff, display with E1;other function icons with not display ,warning with burner .

Remark : ①when in the open circuit state, warning time need delay 5 min .②when sensor is short circuit ,display with E2 ,other function icons not display ,warning with burner.

2.Over temperature protection : when the oven cavity temperature reach the thermostat 180 °C (355°F) , the oven will turn off.

Warning

This content is compiled from multiple sources and is provided for reference purposes only. It may not be complete or fully applicable to all situations. If you are unable to resolve your issue, please contact the product manufacturer or an authorized service provider for official support.