

## Operations

### Main panel

#### Type A

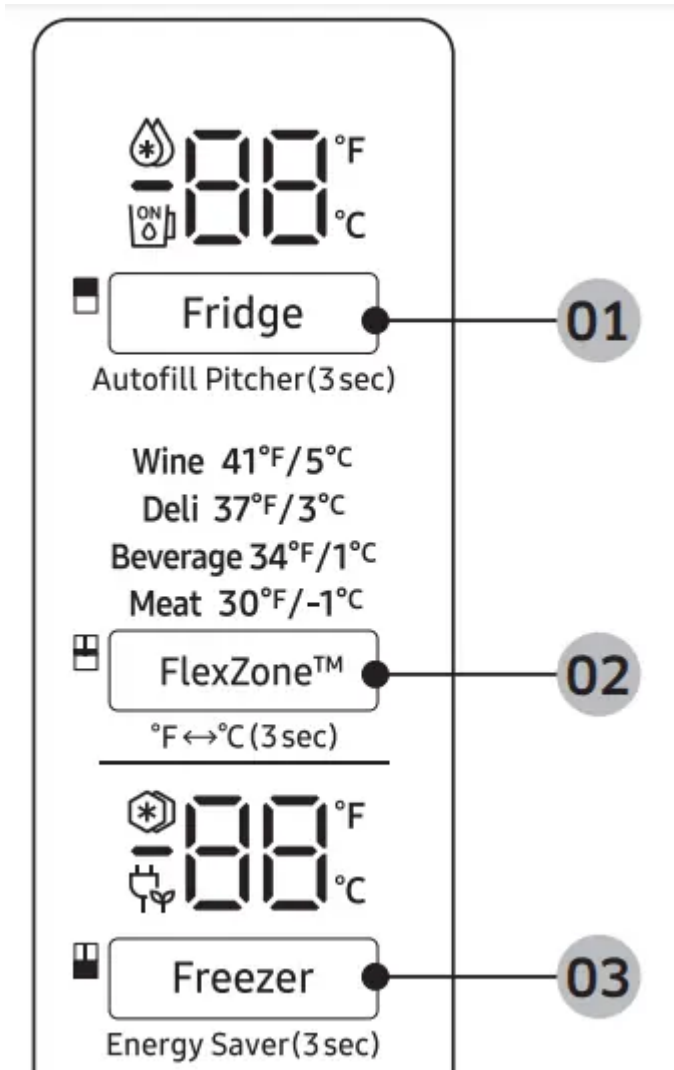

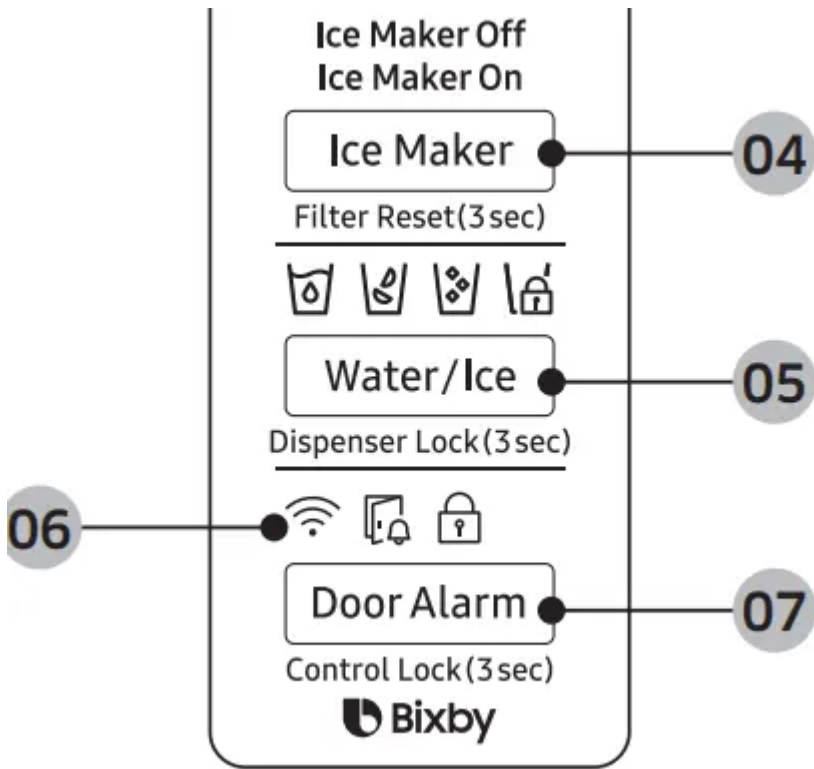

Type B



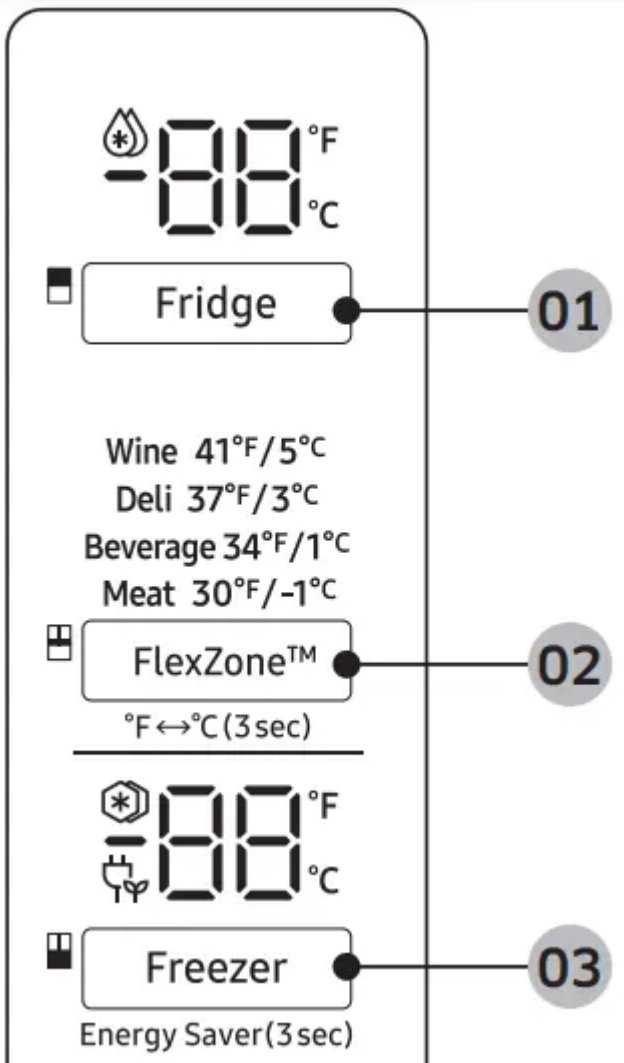

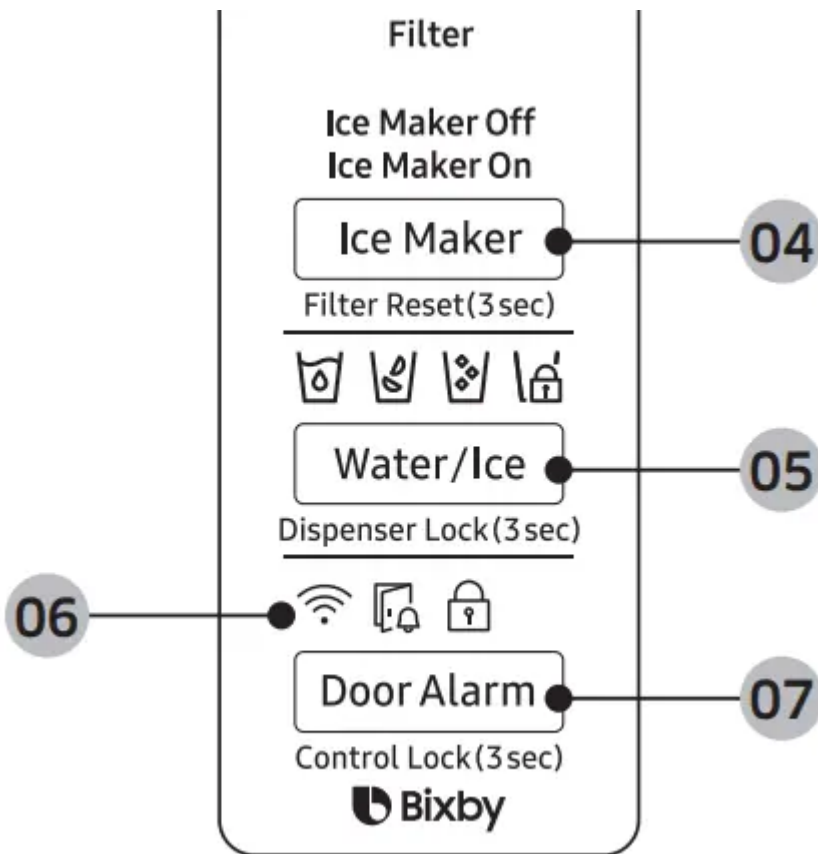

01 Fridge / Auto Fill Water Pitcher \*

02 FlexZone™ / °F ↔ °C

03 Freezer / Energy Saver

04 Ice Maker / Filter Reset

05 Water/Ice / Dispenser Lock

06 Network connection

07 Door Alarm / Control Lock

\* applicable models only

### 01 Fridge / Auto Fill Water Pitcher (3 sec)

### 02 FlexZone™ / °F °C (3 sec)

The FlexZone™ is a full-width drawer featuring temperature control. It has a temperature sensor that adjusts the amount of cold air allowed into the zone.

- Press FlexZone™ repeatedly to select a desired mode. By default, Deli is selected.
- The refrigerator adjusts the temperature in the FlexZone™ according to the selected mode.

### 03 Freezer / Energy Saver (3 sec)

#### **04 Ice Maker / Filter Reset (3 sec)**

#### **05 Water/Ice / Dispenser Lock (3 sec)**

#### **06 Network connection**

You can control and monitor your refrigerator on the SmartThings app. For more information, see the SmartThings section.

#### **07 Door Alarm / Control Lock (3 sec)**

### **SmartThings**

#### **Installation**

Visit the Google Play Store, Galaxy Apps, or Apple App Store and search for "SmartThings". Download and install the SmartThings app provided by Samsung Electronics to your smart device.

#### **Samsung account**

You are required to register your Samsung account to use the app. If you don't have a Samsung account, follow the app's onscreen instructions to create a free Samsung account.

#### **Getting started**

Turn on the device you want to connect, open the SmartThings app on your phone, and then follow the instructions below. If a pop-up appears saying that a new device has been found, tap ADD NOW. If a pop-up doesn't appear, tap the + button, and then select the device you want to connect from the list of available devices. If your device isn't in the list of available devices, tap Supported Devices, select the device type (Refrigerator), and then select the specific device model. Follow the instructions in the app to set up your device. Once setup is complete, your refrigerator will appear as a "card" on your Devices screen.

#### **Refrigerator app**

#### **Integrated control**

You can monitor and control your refrigerator at home and on the go.

- Tap the refrigerator icon on the SmartThings Dashboard or tap the Devices icon at the bottom of the Dashboard, and then tap the refrigerator "card" to open the Refrigerator page.
- Check the operation status or notifications related to your refrigerator, and then change options or settings if necessary.

#### **Dispenser panel**

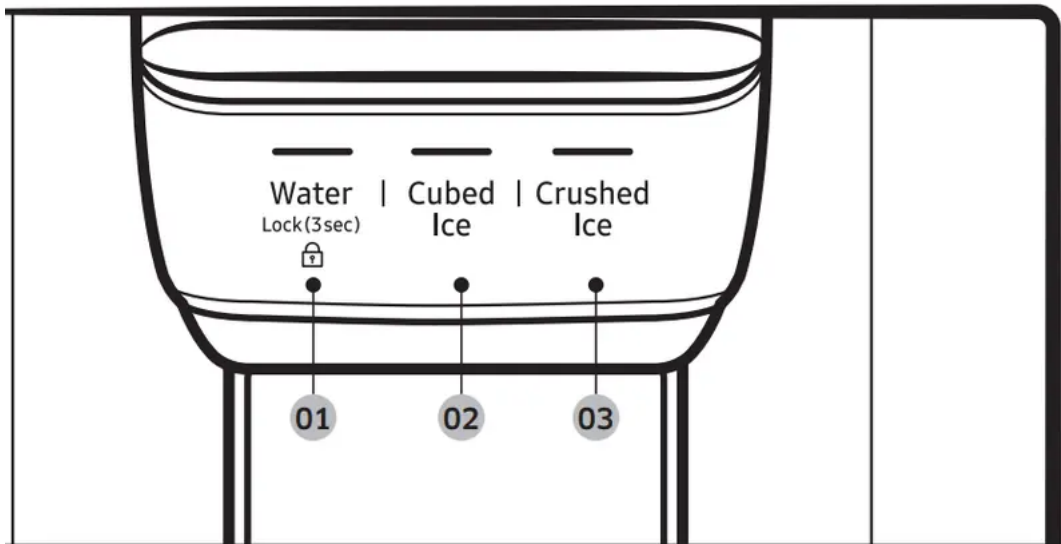

01 Water / Lock

02 Cubed Ice

03 Crushed Ice

**01 Water / Lock (3 sec)**

**02 Cubed Ice**

**03 Crushed Ice**

### **Special features**

#### **Water tank (Auto Water Fill) (applicable models only)**

The Auto Water Fill function lets you enjoy cold brewed tea in your refrigerator.

01 Lid

02 Sealed mouth

03 Infuser

04 Body

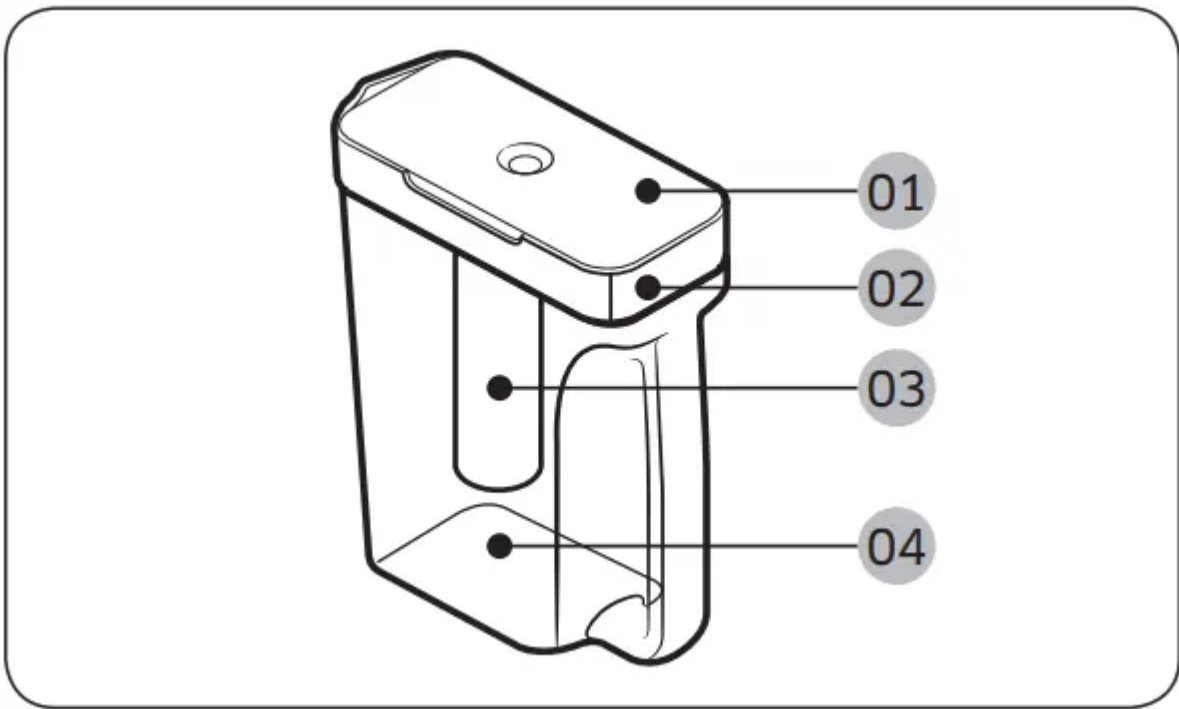

To fill the water tank

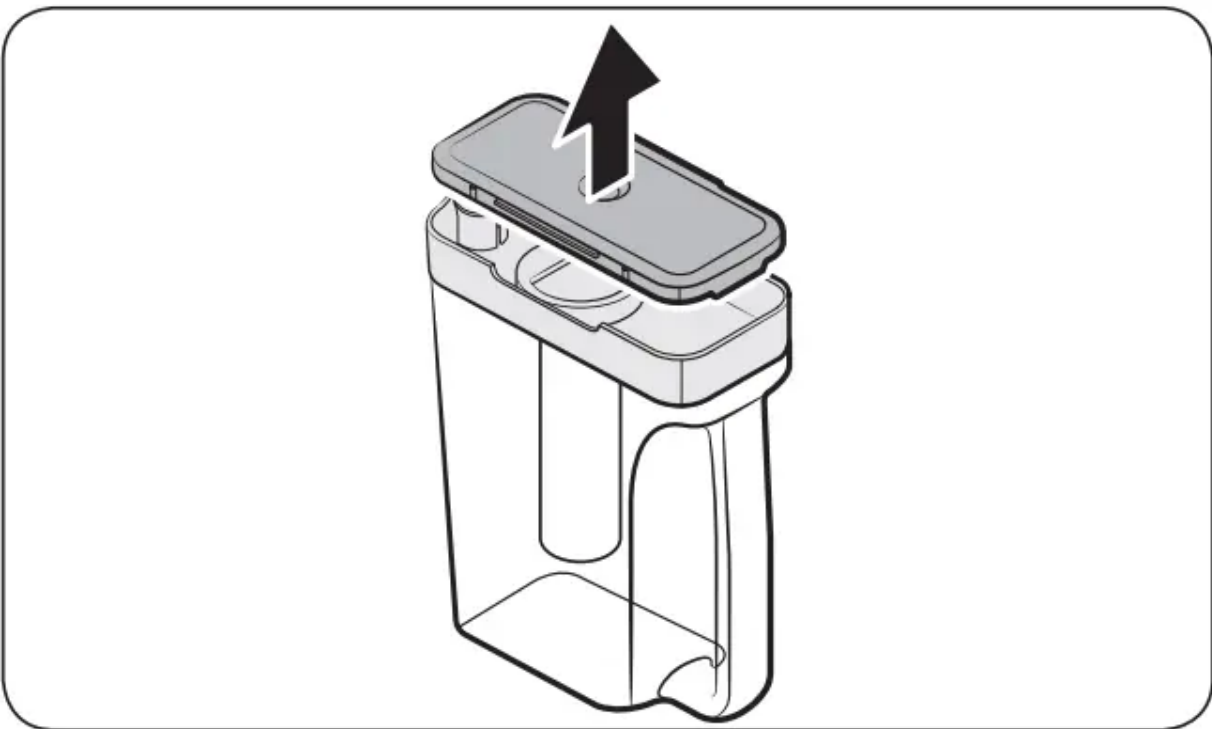

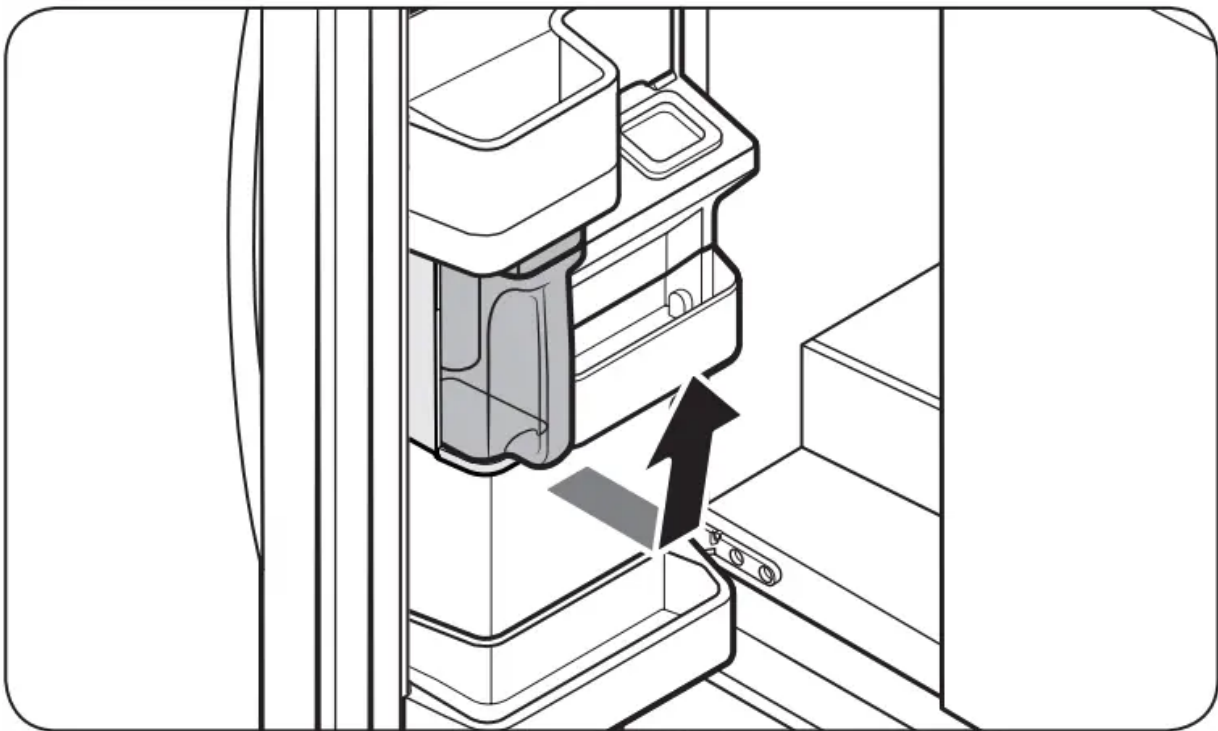
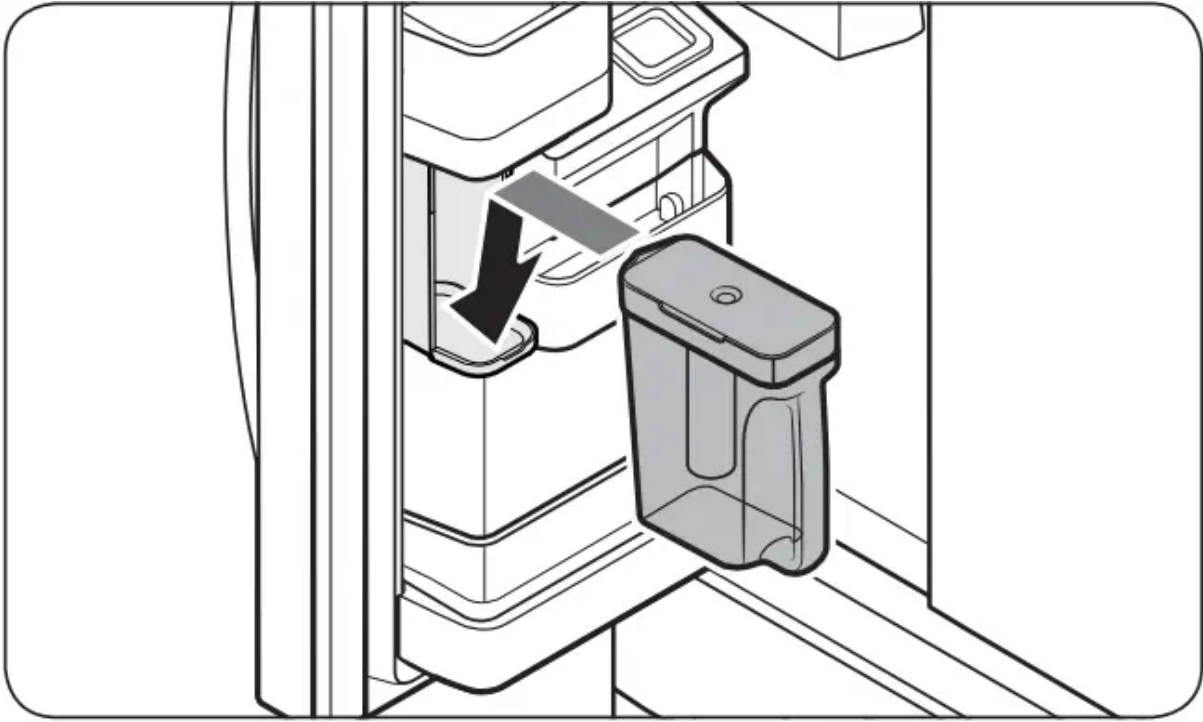

1. Grasp a handle groove of the sealed mouth, and then pull up to open the lid.
2. Put tea leaves or fruit to your taste into the infuser.
3. Enable the Auto Water Fill function on the main panel. Open the left door of the fridge door, and then mount the water tank onto the holder. Push it straight in as shown in the illustration on the left.
4. Close the door. The infuser will start to fill with chilled water a short time later.
5. To drink tea, open the door and detach the water tank. Pull it straight out.

## Water/Ice dispenser

Using the dispenser, you can dispense water with or without ice. The water dispenser offers 3 options: chilled water, cubed ice, and crushed ice. To dispense chilled water, press Water on the dispenser panel. Put a water glass under the dispenser, and then push the dispenser lever.

To dispense water with ice

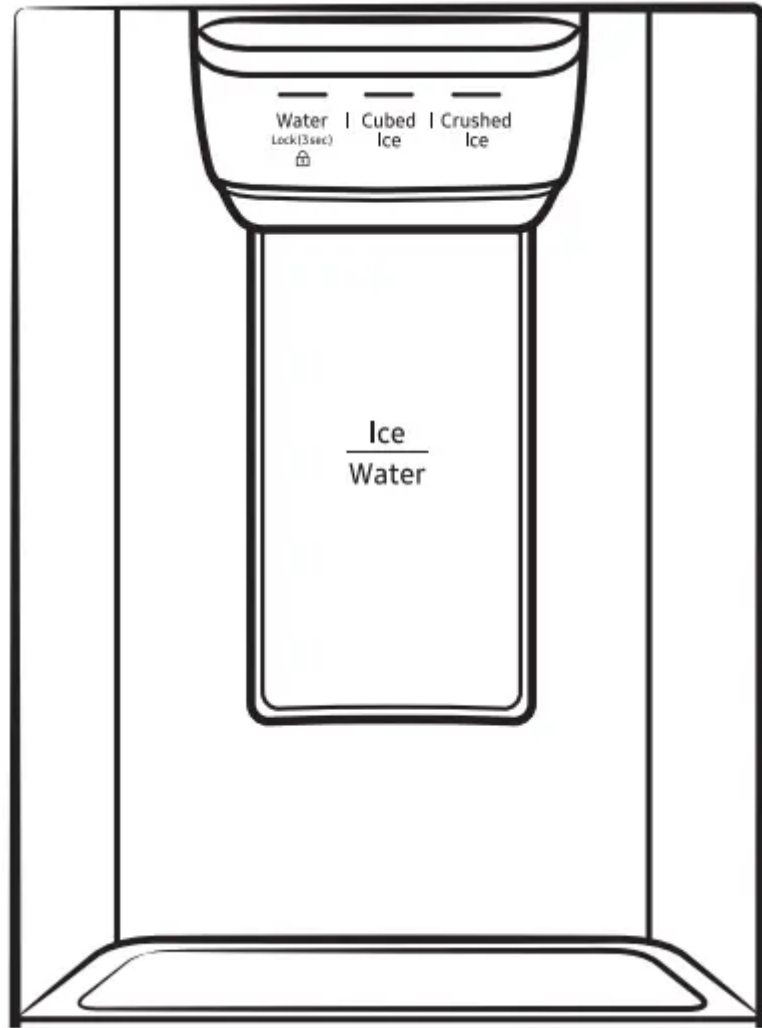

1. With the Ice Maker enabled, press Cubed Ice or Crushed Ice to select the ice type.
2. Put a water glass under the dispenser, and then push the dispenser lever with the glass. Ice will be dispensed from the dispenser.
3. Press Water to select water.
4. Push the dispenser lever with the glass. Water will be dispensed from the dispenser.

## Ice maker

The refrigerator has a built-in ice maker that automatically dispenses ice so that you can enjoy filtered water with cubed or crushed ice.

## Ice making

After you have installed your refrigerator and plugged it in, follow these instructions to ensure proper ice making and to keep the ice bucket full of ice:

1. Let the refrigerator operate for at least 24 hours to ensure optimal performance.
2. Dispense the first 4 to 6 ice cubes into a glass.
3. Wait another 8 hours and dispense another 4 to 6 ice cubes.
4. Then, wait another 16 hours and dispense the first glass-full of ice.

## Diagnosis

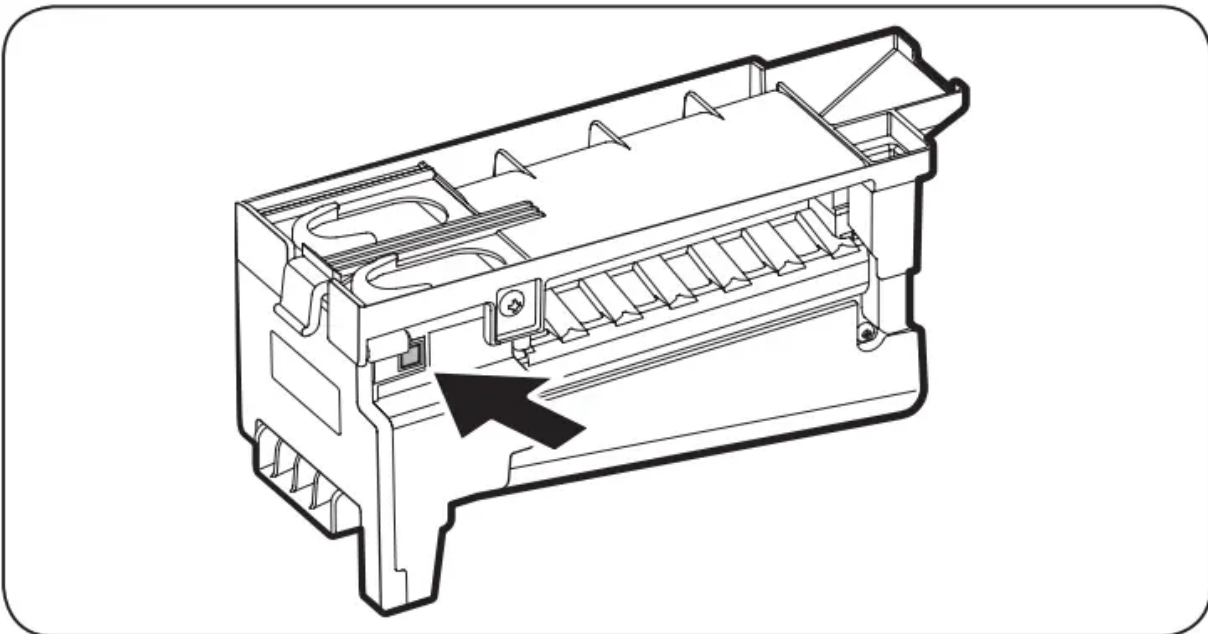

If ice does not dispense, first check the ice maker.

1. Press Test on the side of the ice maker. You will hear a chime (ding-dong) when you press the button.
2. You will hear another chime if the ice maker is operating properly.

## If You Turn the Ice Maker Off

If you press and hold Ice Maker for more than 3 seconds to turn the ice maker off, make sure to remove all ice cubes from the ice bucket. Remaining ice cubes may clump together, making it difficult to remove them. To remove the ice bucket, see the Ice bucket (applicable models only) section on page 67.

## Water clouding

Water supplied to the refrigerator flows through a core alkaline filter. During this filtering process, the water pressure of the water increases and the water becomes saturated with oxygen and nitrogen. This causes the water to look

misty or cloudy temporarily when dispensed. This is normal and the water will look clear after a few seconds.

### FlexZone™ divider

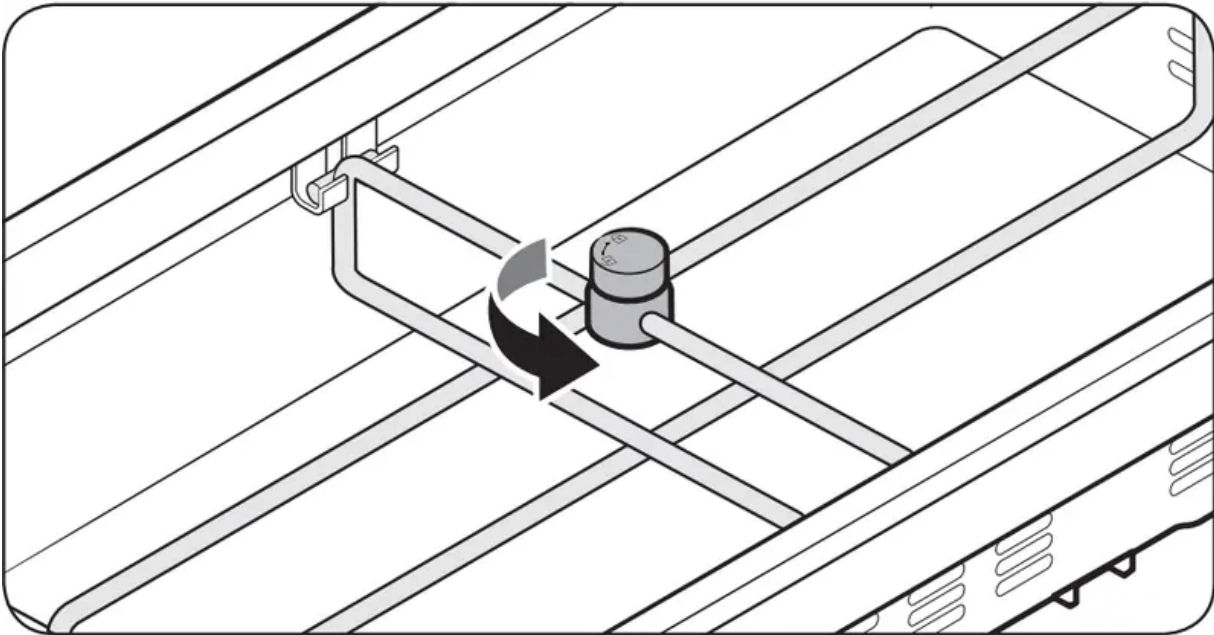

You can change the divider position. To do this, unlock the divider by turning the divider dial counter clockwise. Then, move the width and height bars as appropriate. When done, turn the dial clockwise to lock the divider.

## Maintenance

### Handling and care

#### Ice bucket (applicable models only)

If you do not dispense ice for an extended period, ice may form clumps inside the bucket. If this happens, remove and empty the ice bucket.

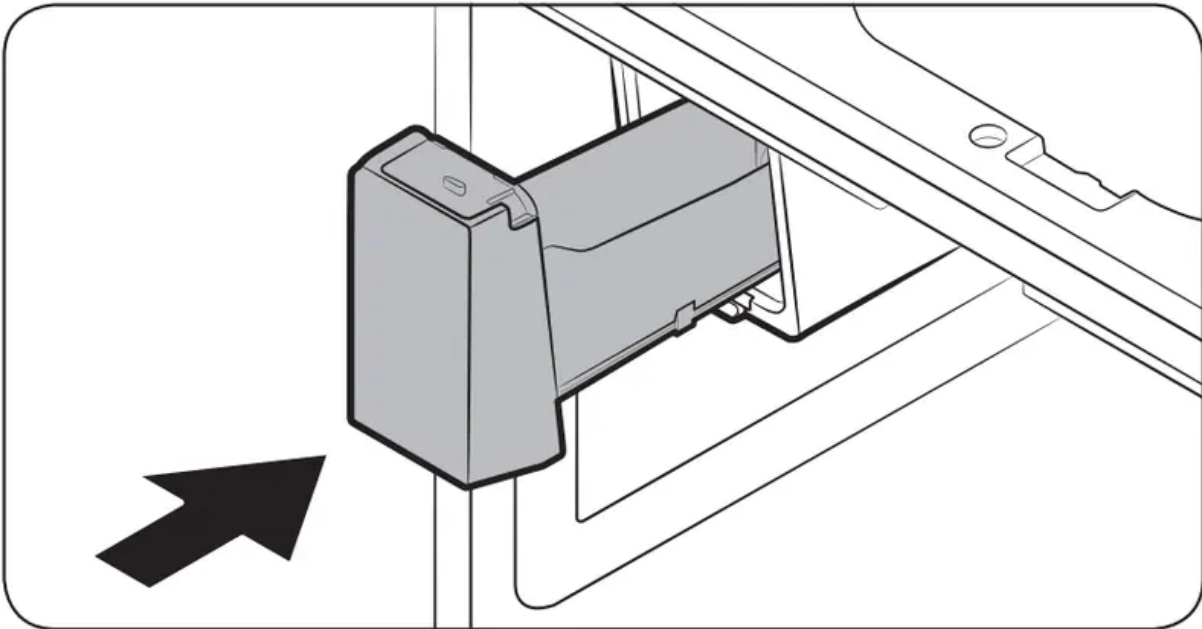
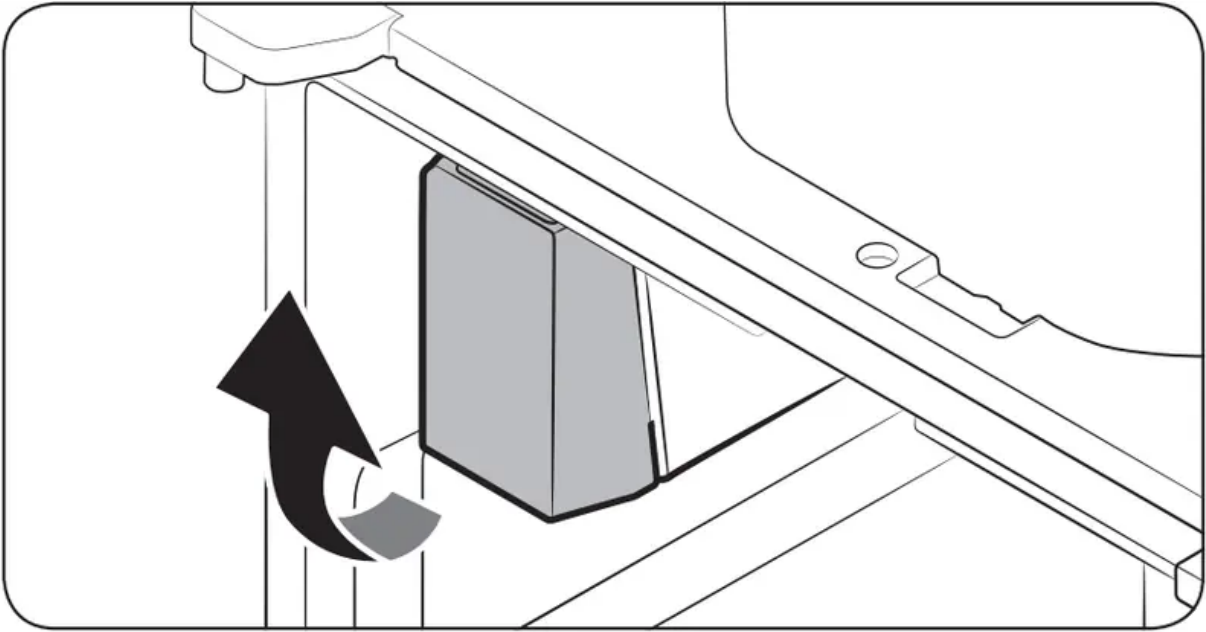

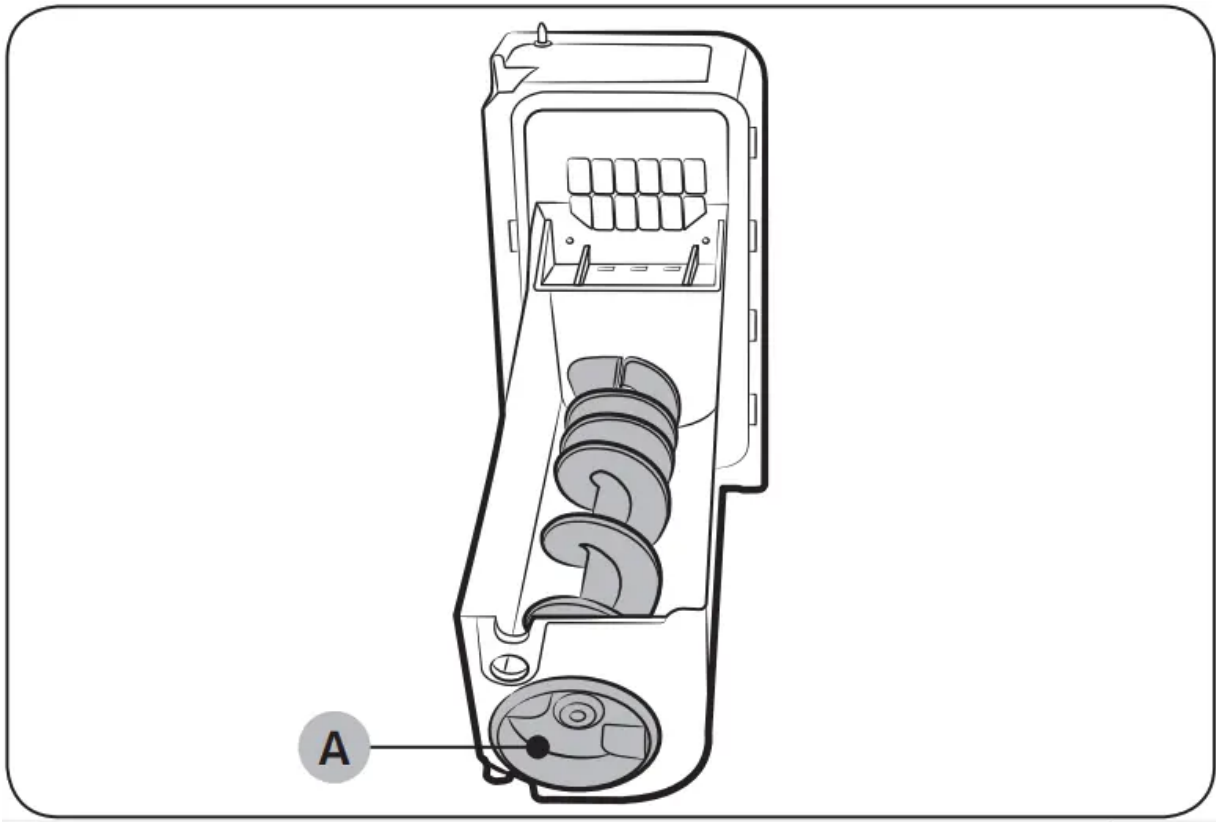

1. To remove the ice bucket, gently lift it up, and then pull it out slowly while holding the bottom of the bucket with one hand and the side with the other hand.
2. Empty the bucket.
3. When done, put the bucket back into position. If the bucket does not fit in, turn the helix screw 90 degrees, and then try again.

If the ice bucket is not firmly inserted, turn the Helix (A) 90 degrees, and then try again.

**Auto Water Fill (applicable models only)**

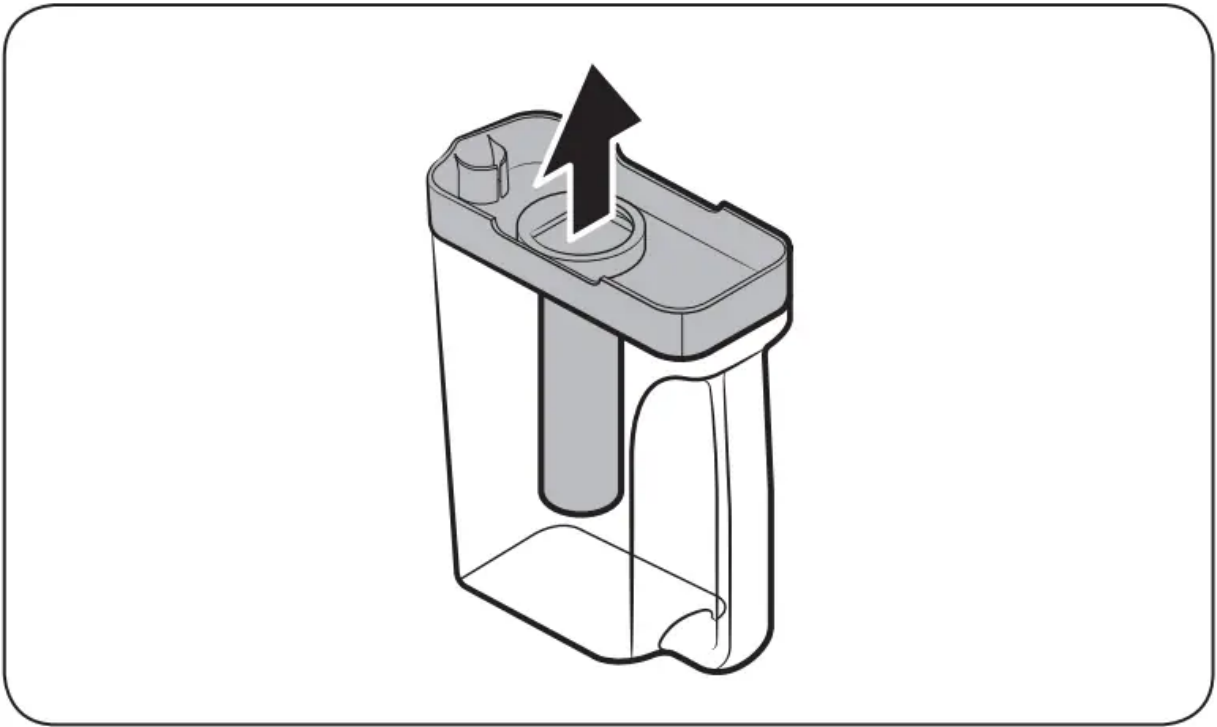
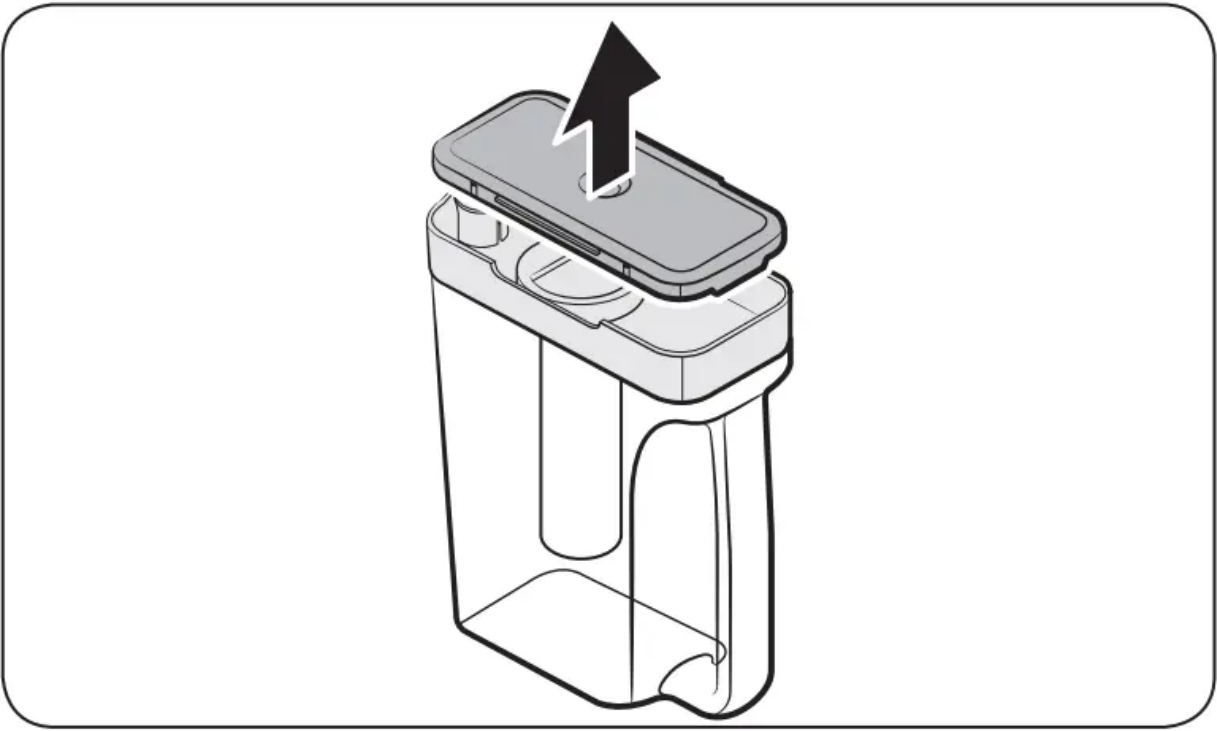

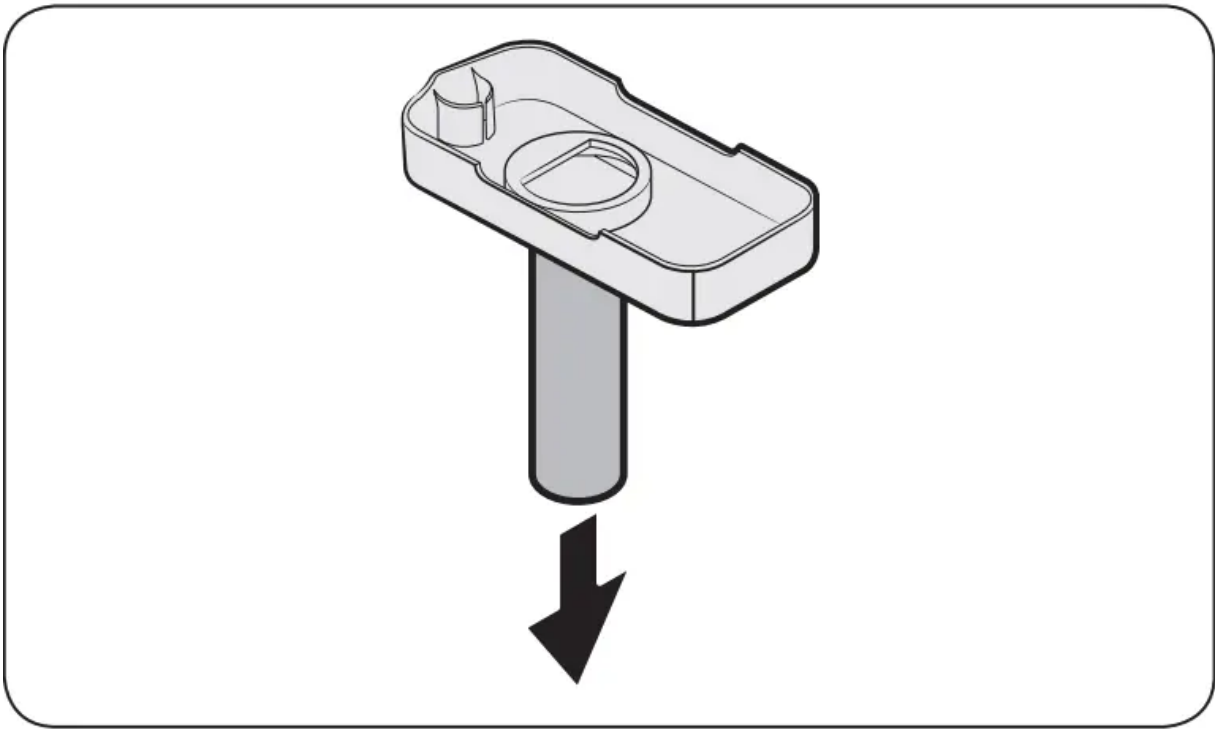

1. Grasp a handle groove of the sealed mouth, and then pull up to remove.
2. Grasp both sides of the sealed mouth, and then lift to remove.
3. While slightly twisting the infuser, pull it out of the sealed mouth.
4. Clean the infuser with neutral agents and running water. Rinse and dry well.
5. Reassemble the Auto Water Fill in the reverse order of disassembly.

### **Fridge shelves**

The appearance of the shelves differs by model.

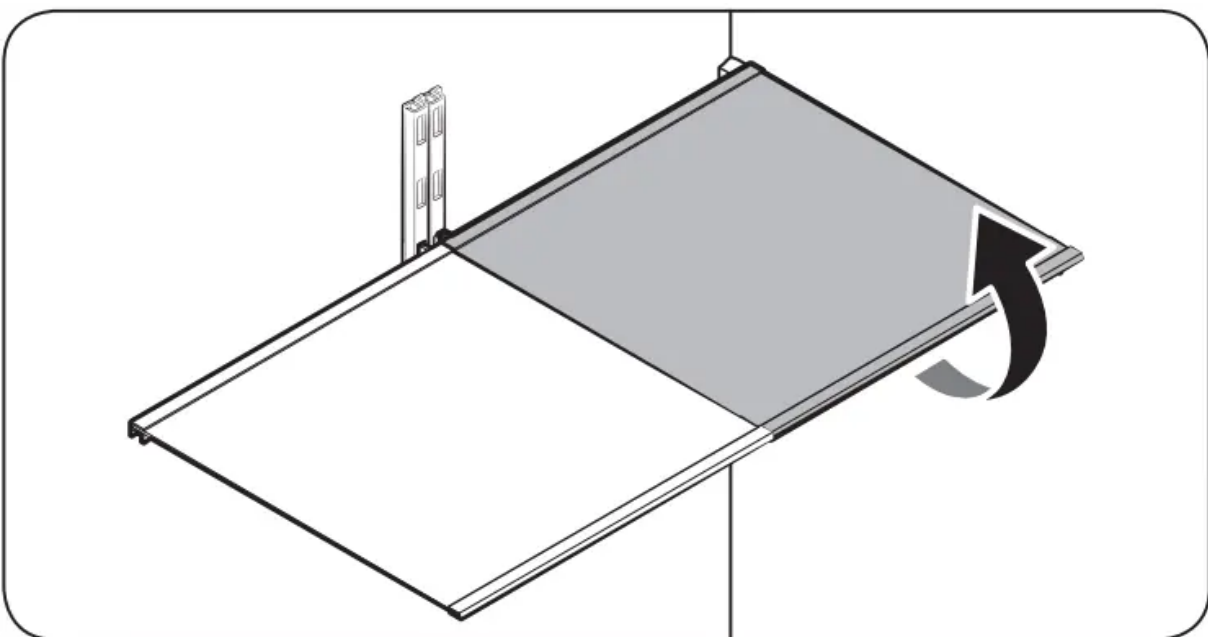

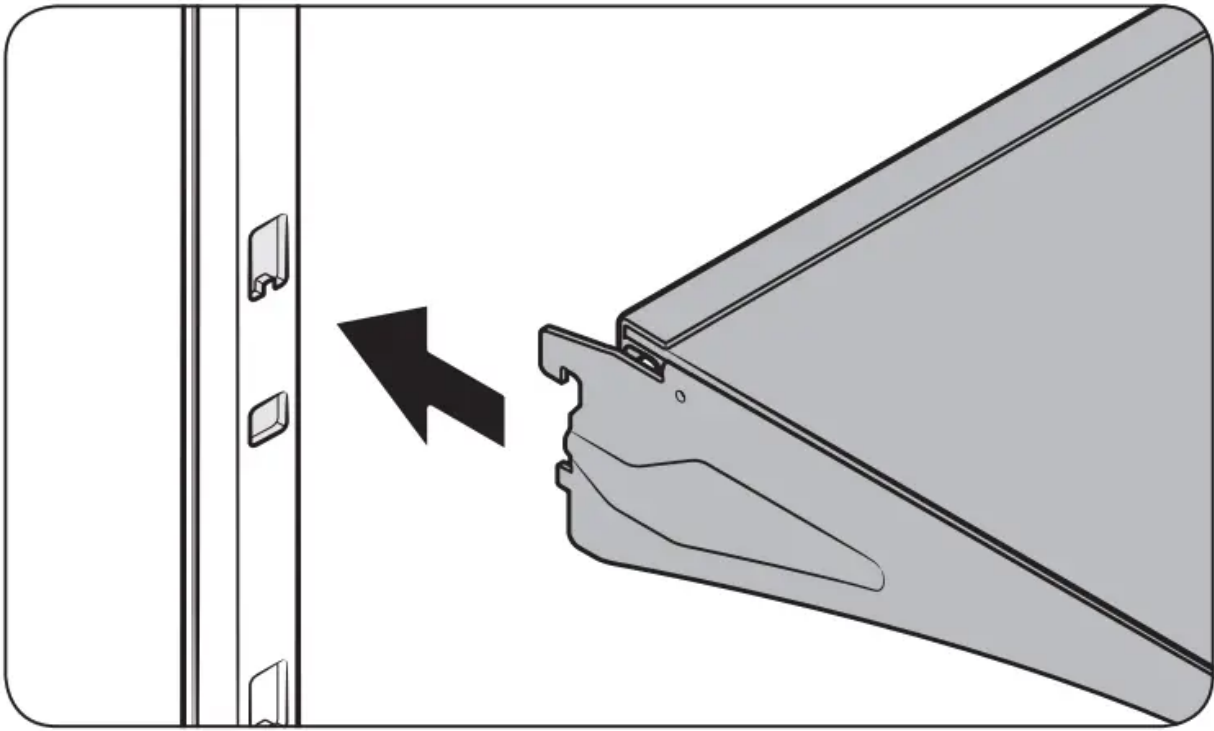

- To remove a shelf, fully open the corresponding door. Hold the front of the shelf, and then gently lift up and slide out.
- To reinsert, hold the shelf at an angle so the front is higher than the back, and then insert the top hook into the top shelf notch. Then, lower the shelf and insert the bottom shelf hook into the bottom shelf notch.

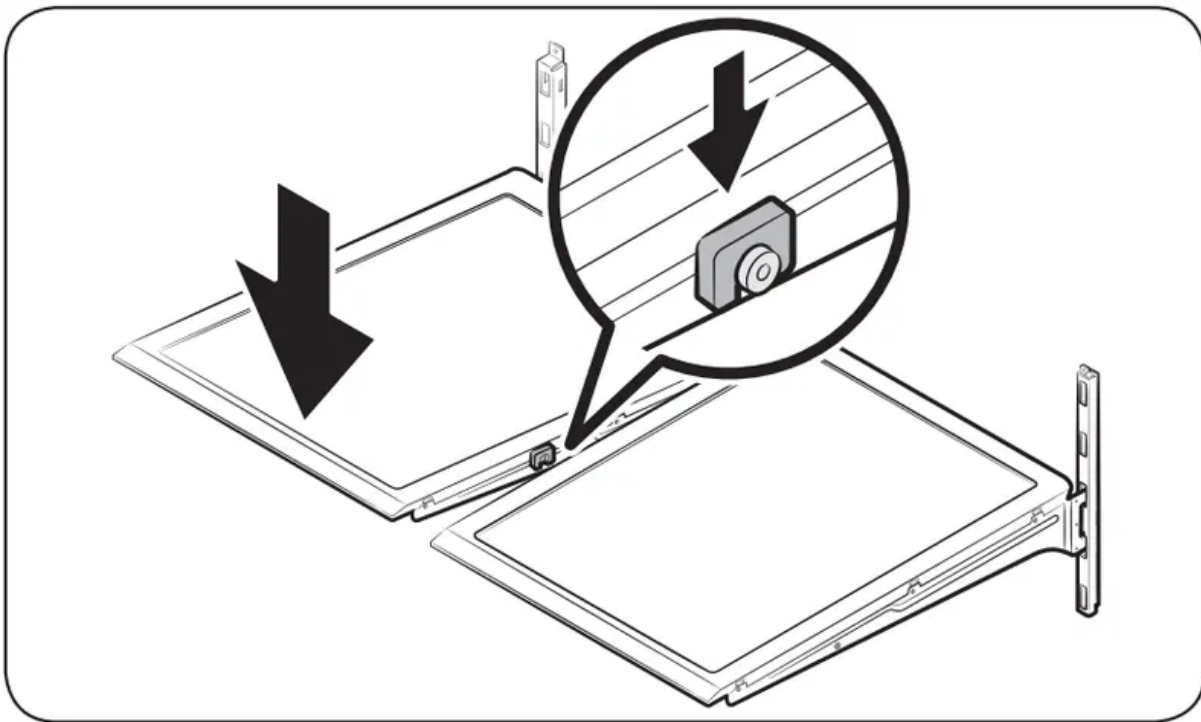

**Foldable shelf**

To remove, slide up the front of the shelf so that it folds. Then gently lift up and pull out. To reinsert, place the shelf on the angled frame in the main unit, and then, press down to unfold.

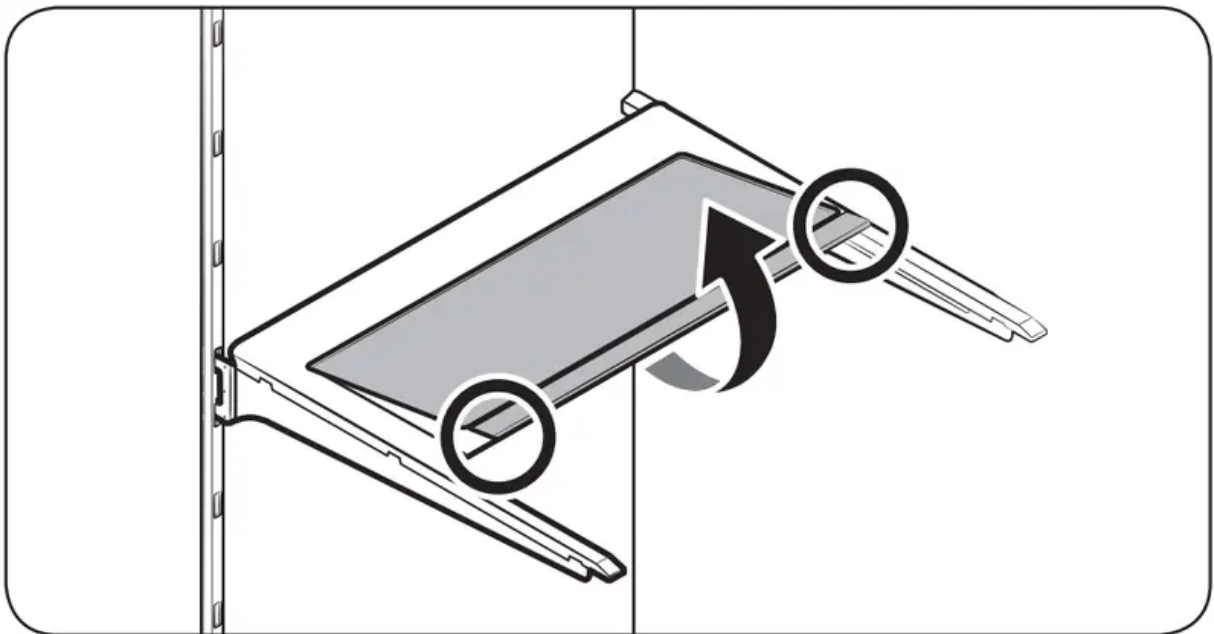
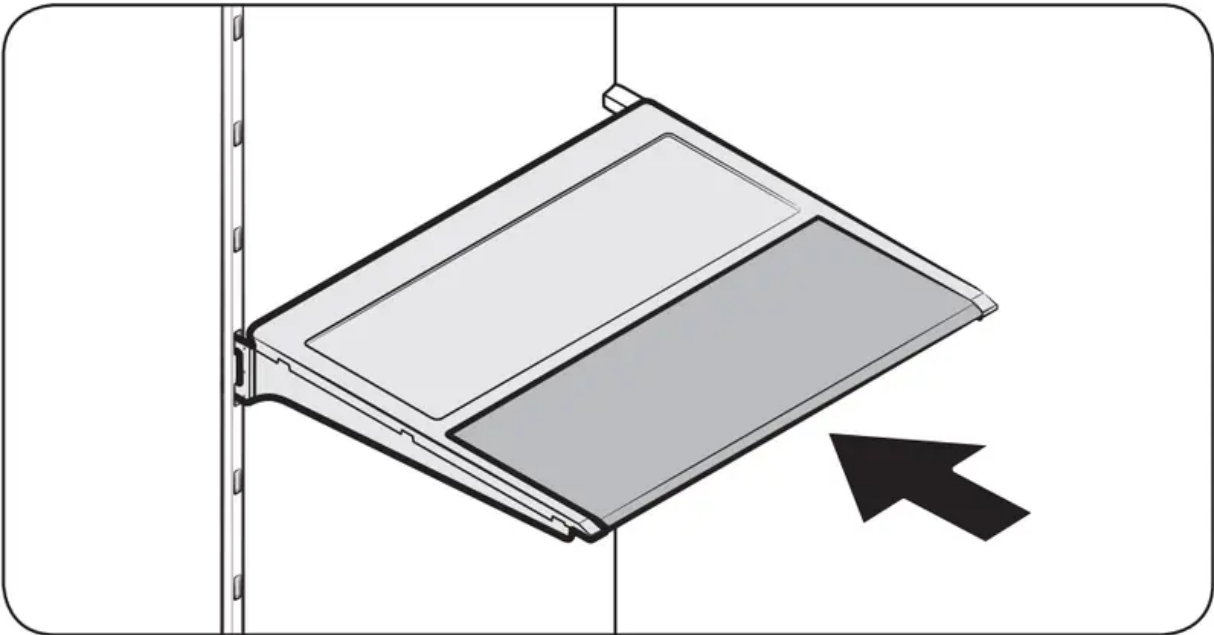

**Recommended foldable shelf location**

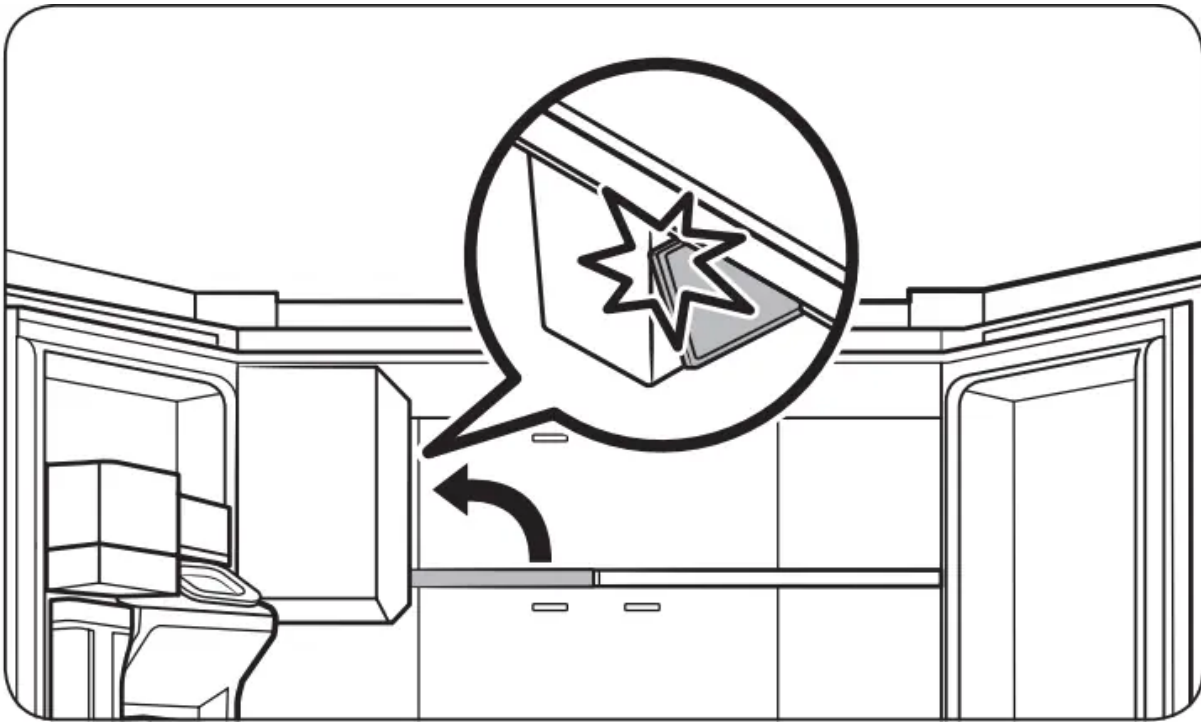

The foldable shelf folds up from the center, giving you more room for storage.

- Insert the shelf in the right side of the fridge. Left side insertion does not allow the shelf to fold completely.
- To fold, push the front area of the shelf inward so that it folds up from the middle.

### **Vegetable shelf**

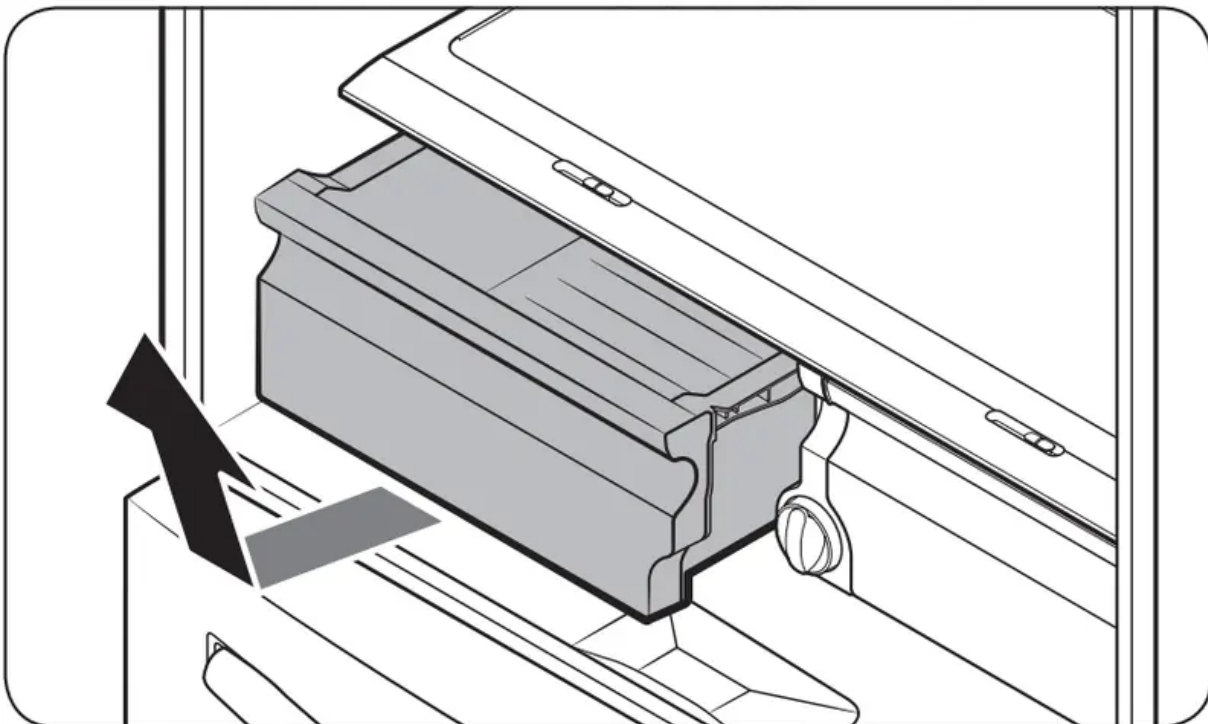

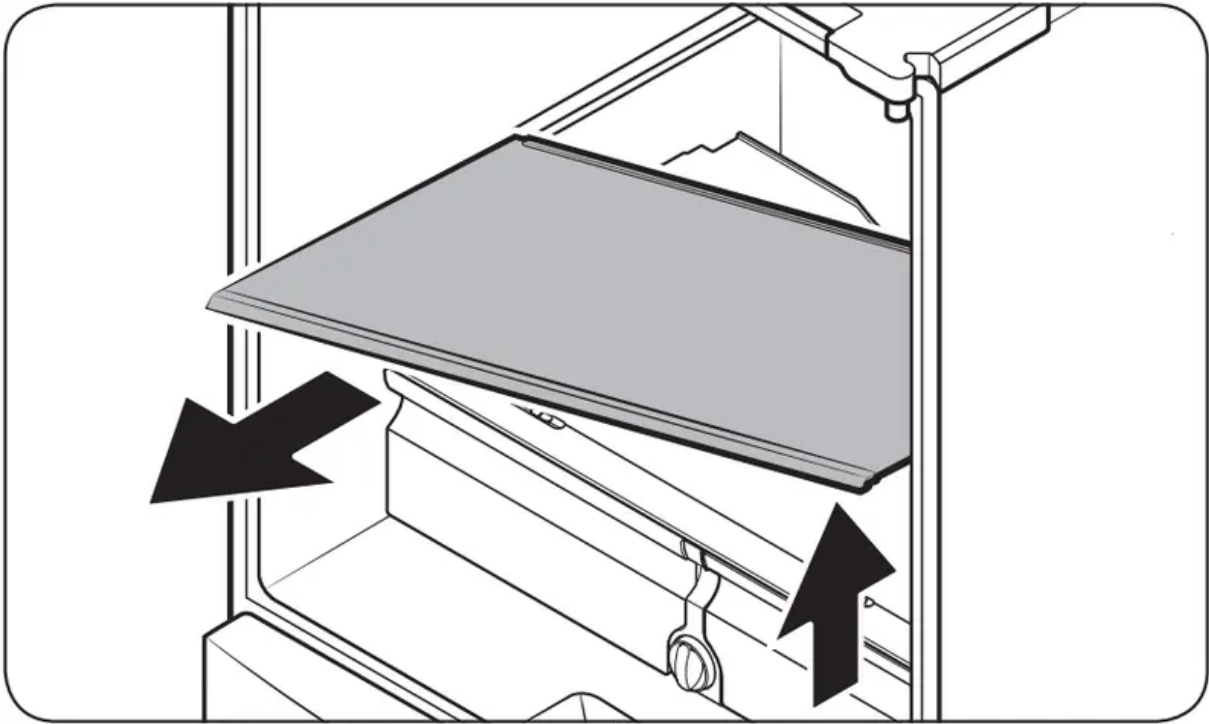

1. Slide out the left-side vegetable drawer.
2. While supporting the vegetable shelf with one hand, slide it out with the other hand.

### Door bins

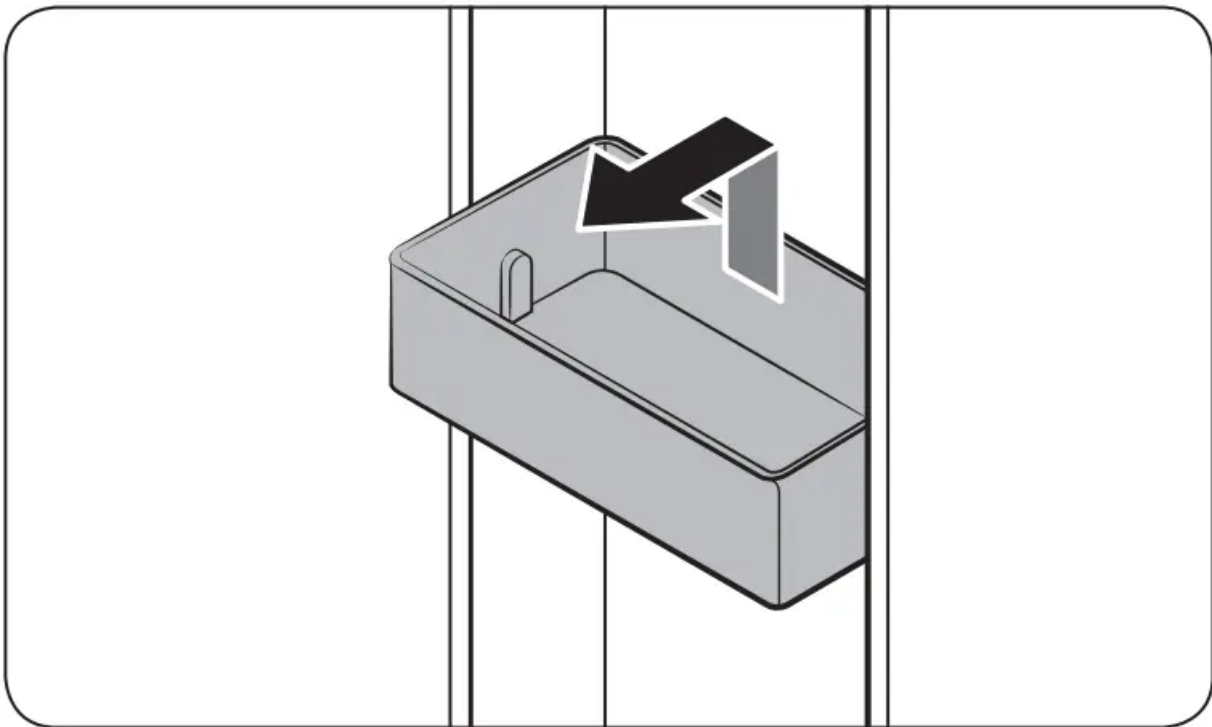

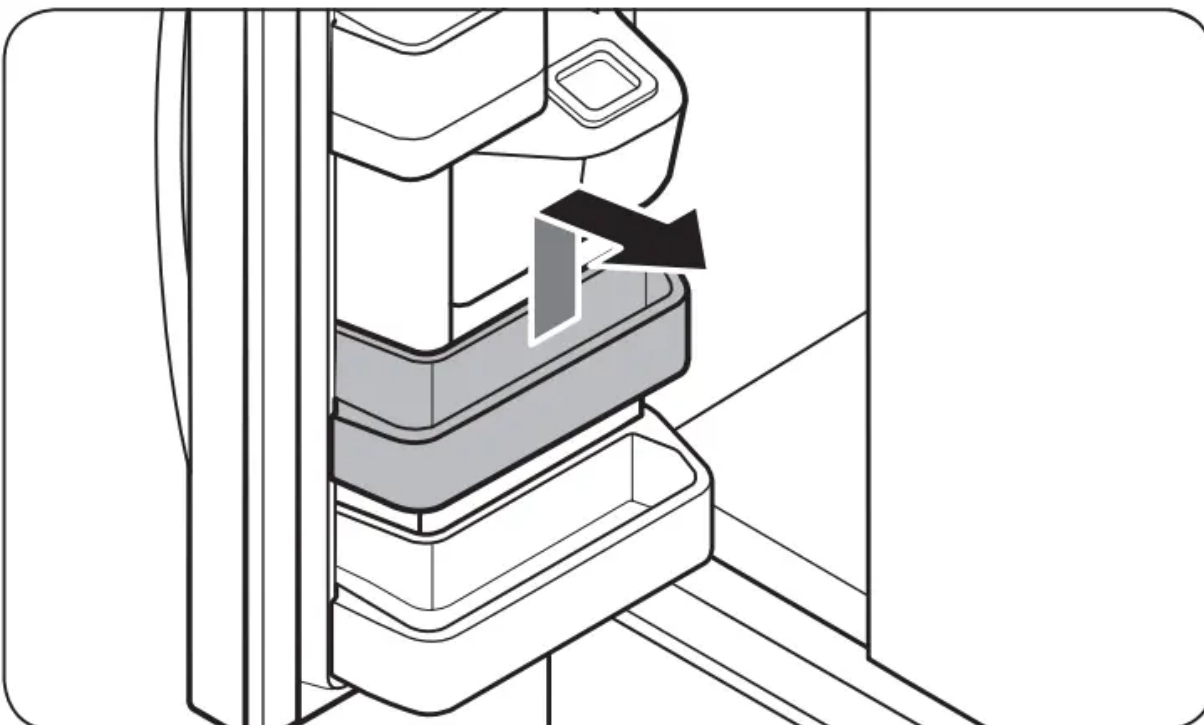
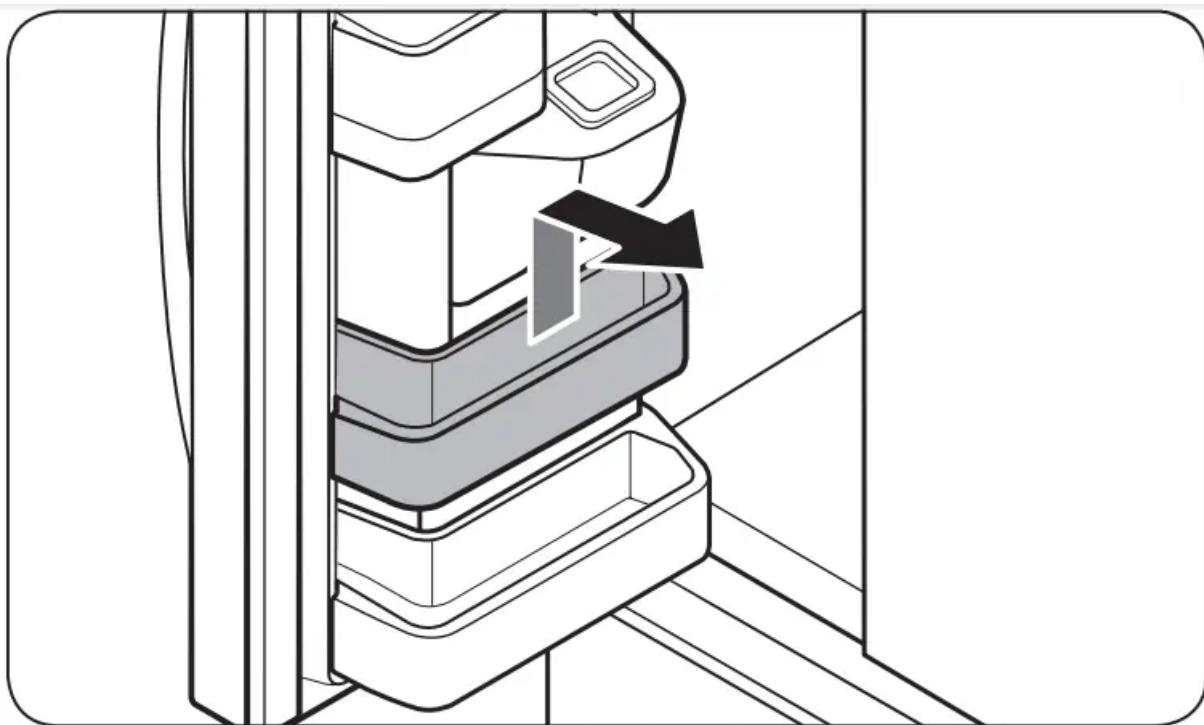

- To remove the top door bin, hold the front sides of the bin, and then gently lift up to remove.
- To reinsert, insert the door bin slightly above its final location making sure that the back of the bin is against the door. Hold the rear of the door bin with both hands, and then press down so that it fits snugly.

### **Fridge drawers**

#### **Vegetable / fruit drawers**

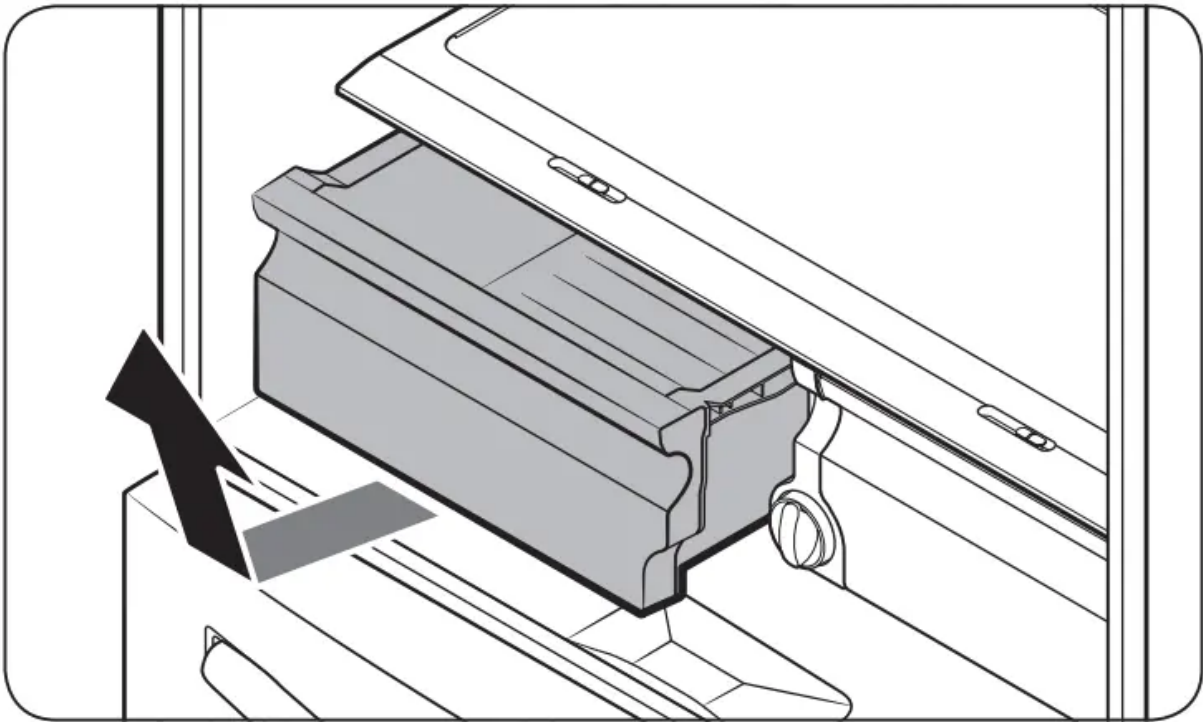

Gently lift up the front of the drawer and slide out.

- We recommend that you remove the door bins before removing the drawer. This is to prevent damage to the door bins.
- To reinsert, insert the drawer into the frame rails and then slide inward.

#### **FlexZone™ basket**

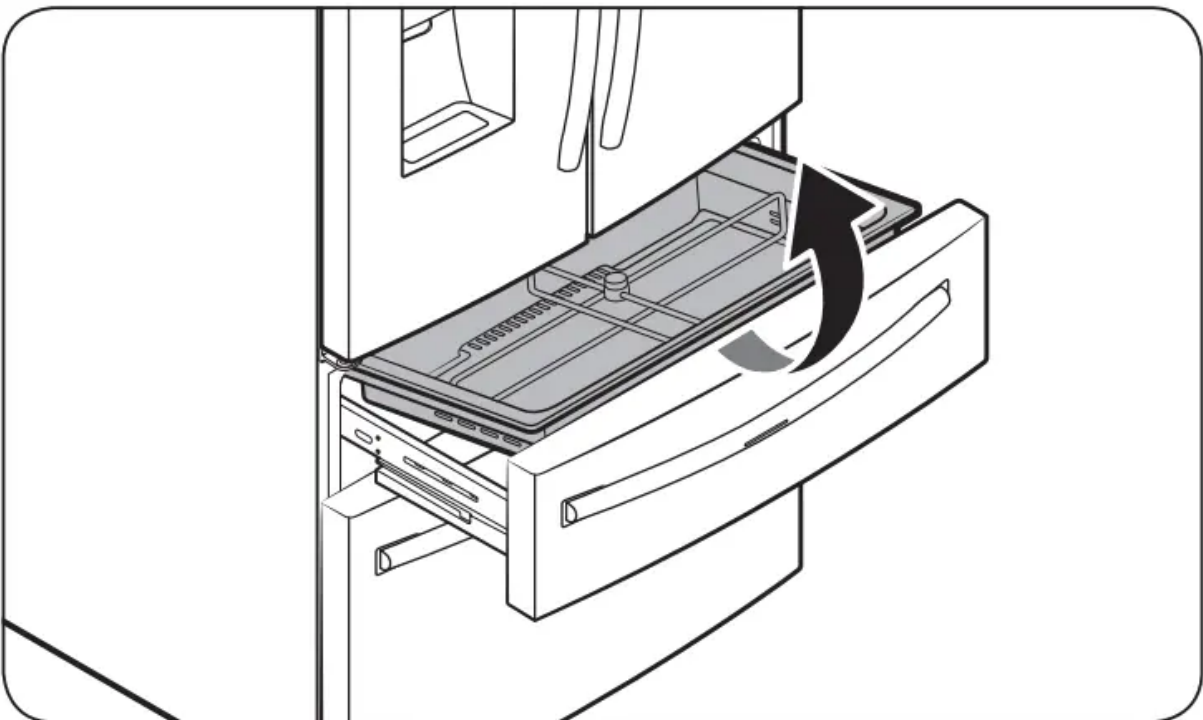

- To remove, fully open the FlexZone™ drawer. Lift up the FlexZone™ basket, and then pull out with both hands.

- To reinsert, fully open the FlexZone™ drawer. While tilting up the front of the basket, insert the rear of the basket into the rail assembly. Lower the front until the basket is in place.
- If the divider lock does not function, wipe the bars to remove moisture on them.

### Freezer baskets

#### Upper basket

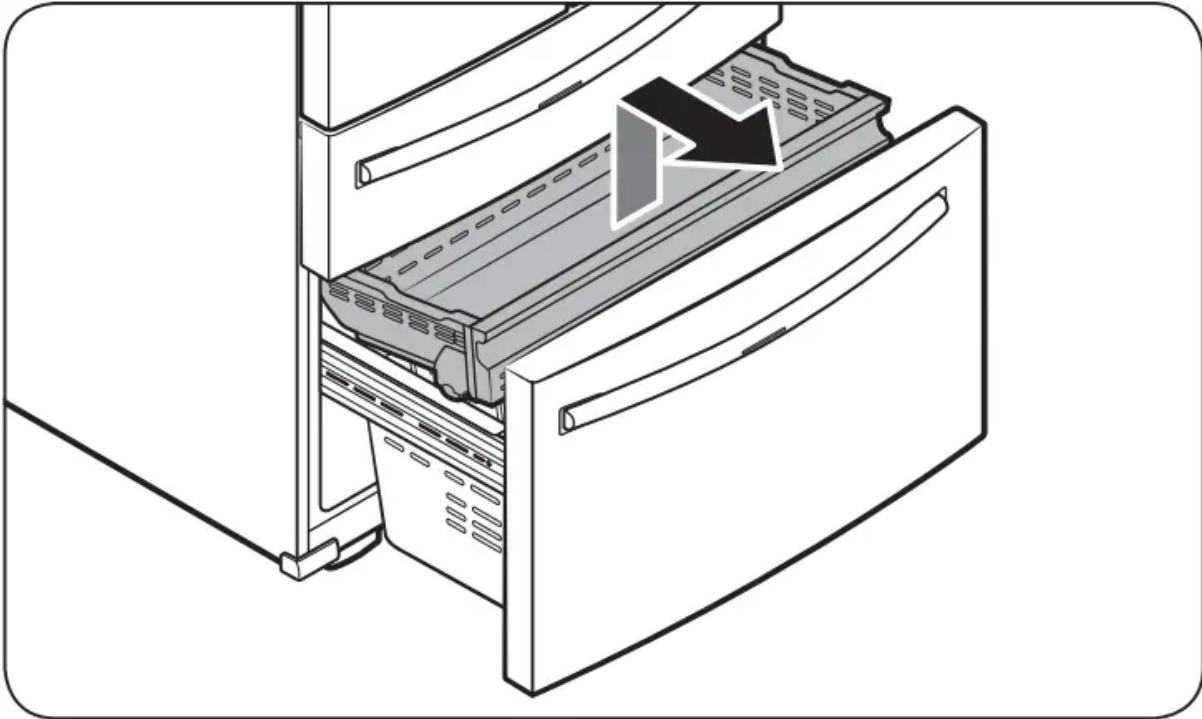

- To remove, fully slide open the freezer drawer. Push the upper basket to the end, and then pull up to remove.
- To reinsert, align the front wheels of the upper basket with the end of the lower basket. Slide the upper basket to the front.

#### Lower basket

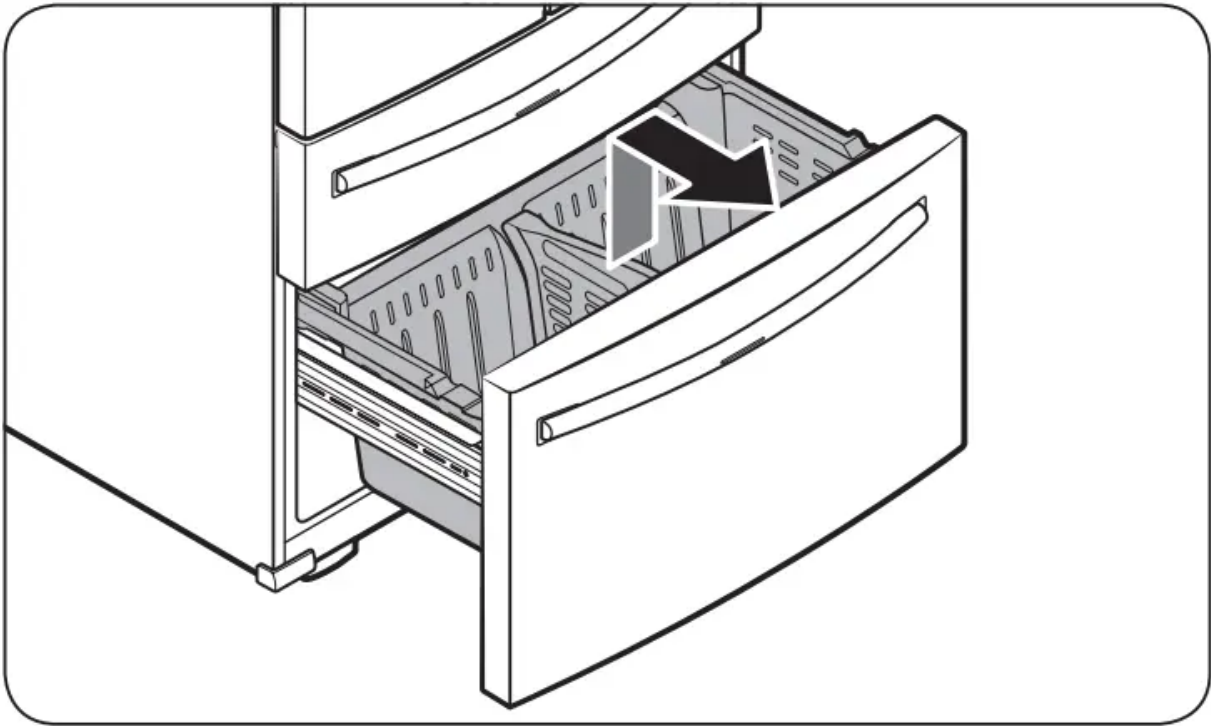

- To remove, first remove the upper basket. Then, tilt up the front of the lower basket to pull out.
- To reinsert, put the basket onto the rail assembly rear side first.

#### Freezer basket divider

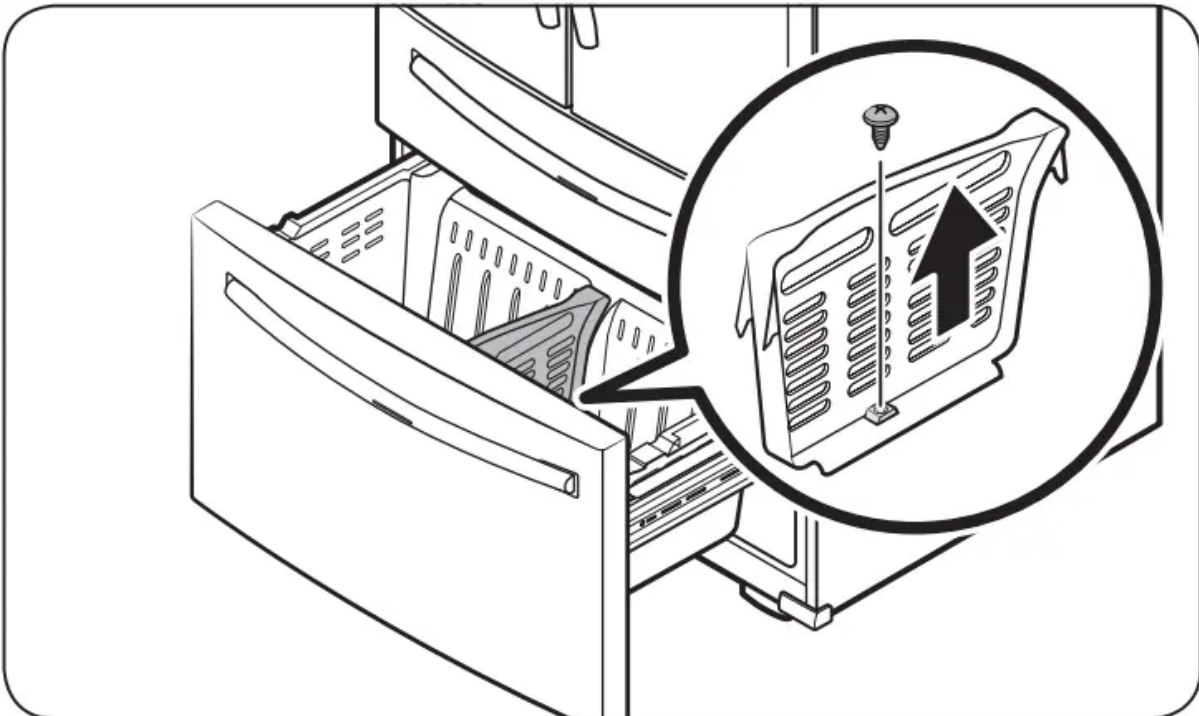

Loosen and remove the screw from the lower side of the divider. Then, pull straight up to remove the divider.

#### Cleaning

### **Interior and exterior**

Regularly use a dry cloth to remove all foreign substances such as dust or water from the power plug terminals and contact points.

1. Unplug the power cord.
2. Use a moistened, soft, lint-free cloth or paper towel to clean the refrigerator's interior and exterior.
3. When done, use a dry cloth or paper towel to dry well.
4. Plug in the power cord.

### **Ice / Water dispenser**

CAUTION : When crushed ice is selected, some residual ice chips may collect in the ice chute. To prevent this, remove the residual ice from the chute using a soft, clean cloth.

### **Rubber seals**

If the rubber seals of a door become dirty, the door may not close properly and reducing refrigerator performance and efficiency. Use a mild detergent and damp cloth to clean the rubber seals. Then, dry well with a cloth.

### **Rear panel**

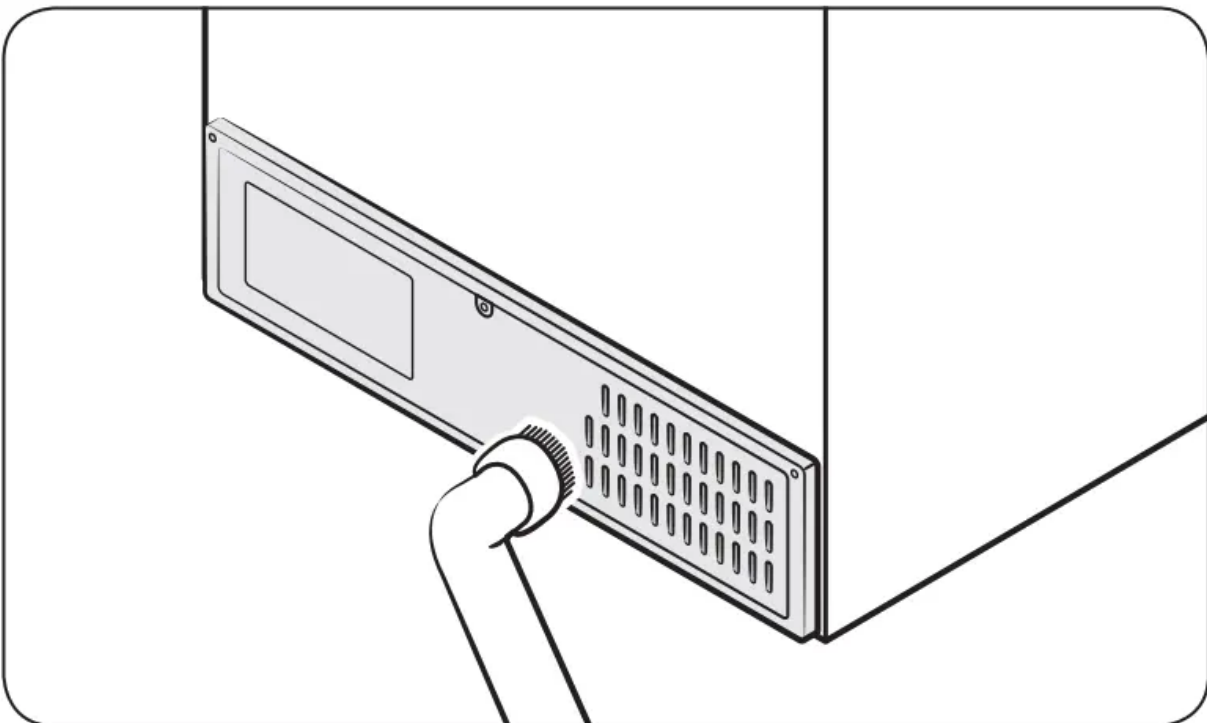

To keep cords and exposed parts of the rear panel free of dirt, vacuum the panel once or twice a year.

### **Replacement**

## Water filter

The Filter Reset indicator (**Filter**) turns red to let you know it is time to replace the water filter. Before replacing the filter, make sure the water supply line is shut off.

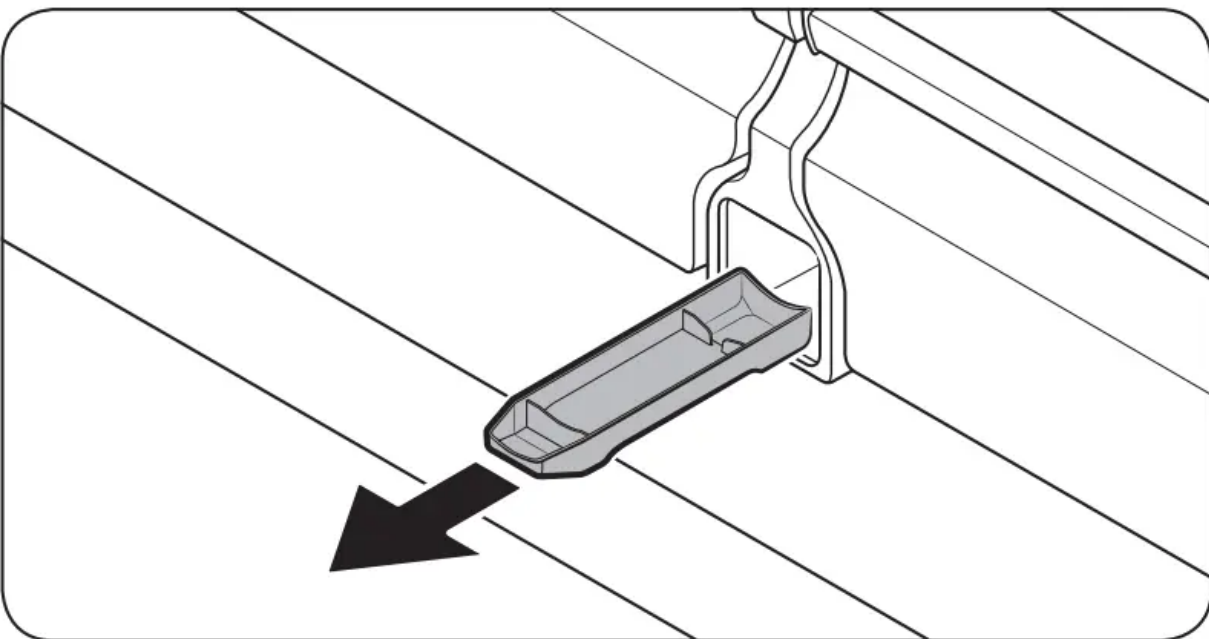
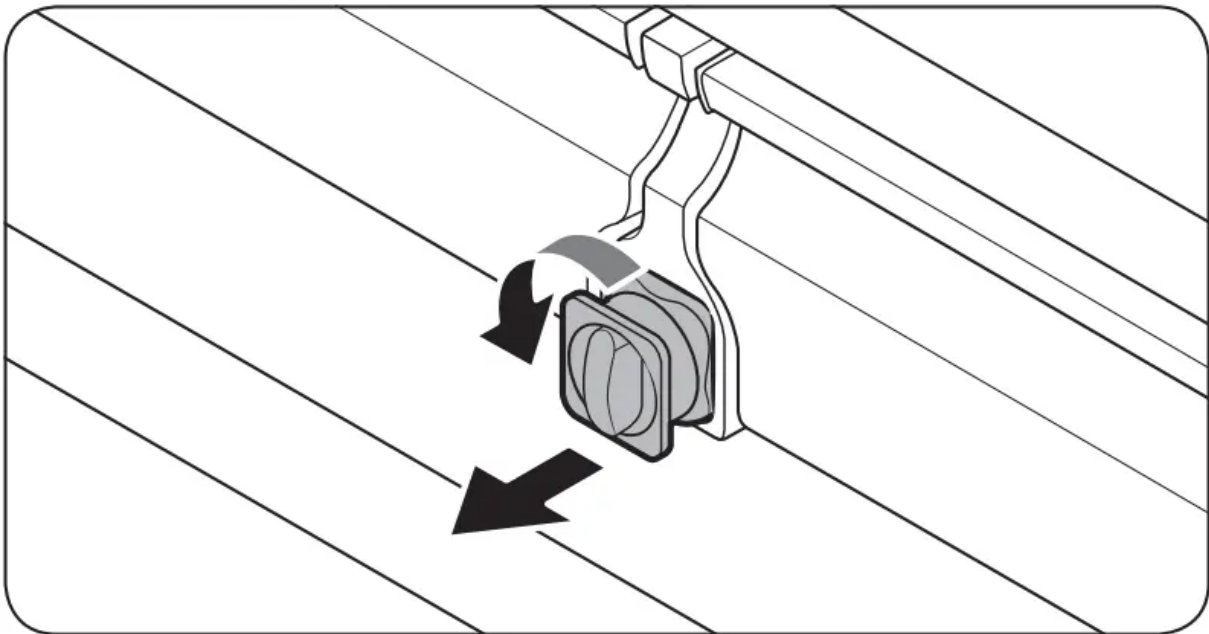

1. Shut off the water supply line.
2. Turn the knob of the filter cartridge counter clockwise 90 degrees (1/4 turn). The filter cartridge unlocks.
3. Pull out to remove the cartridge.
  - If the water filter is severely contaminated, the cartridge may not be easy to remove. If that is the case, use force to remove the cartridge.

- To prevent water leaks from the filter opening, pull the cartridge straight out while removing it.

4. Insert a new filter cartridge. Use only Samsung-provided or approved filters.
5. Turn the cartridge knob clockwise to lock into place.
6. Press and hold Filter Reset on the main panel for 3 seconds to reset the life cycle detector. The Filter Reset indicator (**Filter**) turns off.
7. When you are done replacing the filter, open the water valve and run water through the dispenser for about 7 minutes. This is to remove impurities and air from the water line.

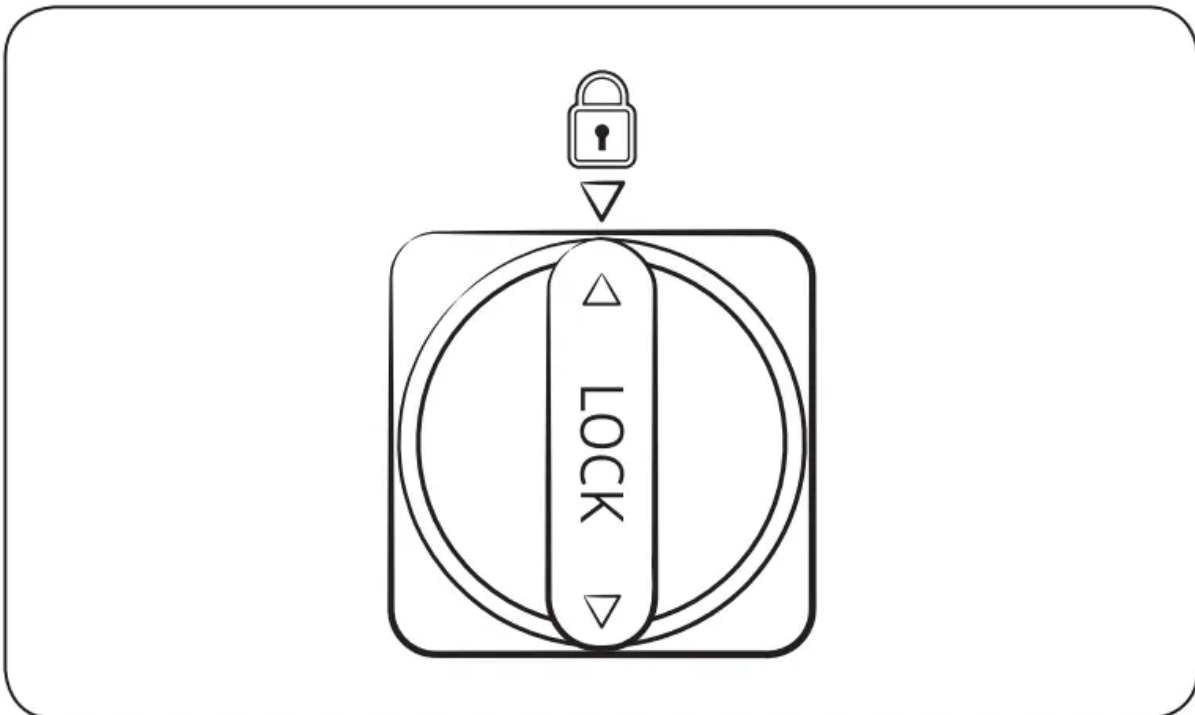

### **Reverse osmosis water filtration system**

The water pressure of the water supply system to a reverse osmosis water filtration system must be between 30 to 120 psi (206 to 827 kPa). The water pressure of the reverse osmosis water filtration system to the refrigerator's cold water line must be at least 40 psi (276 kPa). If the water pressure is below these specifications:

- Check if the sediment filter in the reverse osmosis system is blocked. Replace the filter if necessary.
- Refill the water tank in the reverse osmosis system with water.
- If your refrigerator has a water filter, it may further reduce the water pressure when used in conjunction with a reverse osmosis system. Remove the water filter.

For more information or servicing, contact a licensed plumbing professional.

### **Ordering a new filter**

To purchase a new water filter, contact a local Samsung service center or visit the web.

### **LED Lamps**

To replace the lamps of the refrigerator, contact a local Samsung service center.

## **Troubleshooting**

### **General**

### **Temperature**

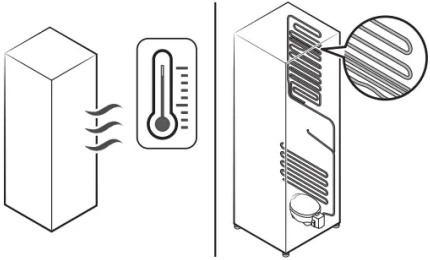

<b>Symptom</b>	<b>Possible causes</b>	<b>Solution</b>
Fridge/freezer does not operate. Fridge/freezer temperature is warm.	Power cord is not plugged in properly	Properly plug in the power cord.
	Temperature control is not set correctly.	Set the temperature lower
	Refrigerator is located near a heat source or direct sunlight.	Keep the refrigerator away from direct sunlight or a heat source.
	Not enough clearance between refrigerator and nearby walls or cabinets.	Make sure there is a gap of at least 5 cm between the refrigerator back and sides and any nearby walls or cabinets.
	Energy Saver mode is activated.	Deactivate Energy Saver mode.
	The refrigerator is overloaded. Food is blocking the refrigerator vents.	Do not overload the refrigerator. Do not allow food to block vents.
Fridge/freezer is over-cooling.	Temperature control is not set correctly.	Set the temperature higher

Interior wall is hot.	Refrigerator has heat-proof piping in the interior wall.	<p>To prevent condensation from forming, the refrigerator has heat-proof piping in the front corners. If the ambient temperature rises, this equipment may not work effectively. This is not a system failure.</p> 
-----------------------	--	---

## Odors

Symptom	Possible causes	Solution
Refrigerator has odors.	Spoiled food.	Clean the refrigerator and remove any spoiled food.
	Food with strong odors.	Make sure strong smelling food is wrapped airtight.

## Frost

Symptom	Possible causes	Solution
Frost around the vents	Food is blocking the vents.	Make sure no food blocks the refrigerator vents
Frost on interior walls.	Door is not closed properly	Make sure food does not block the door. Clean the door gasket.
Fruits or vegetables are frozen.	Fruits or vegetables are stored in the FlexZone™.	Do not store most kinds of fruit or vegetables in the FlexZone™.

## Condensation

<b>Symptom</b>	<b>Possible causes</b>	<b>Solution</b>
Condensation forms on the interior walls	If door is left open, moisture enters the refrigerator.	Remove the moisture and do not leave a door open for extended periods of time
	Food with high moisture content.	Make sure food is wrapped airtight.

**Water/ice (dispenser models only)**

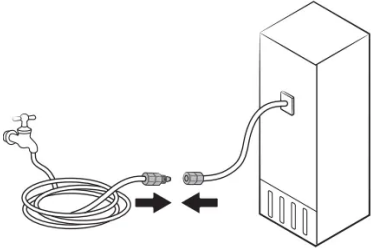

Symptom	Possible causes	Solution
Water flow is weaker than normal.	Water pressure is too low.	Make sure the water pressure is between 30 to 120 psi (206 to 827 kPa).
Ice maker makes a buzzing sound.	The ice maker function is activated, but the water supply to the refrigerator has not been connected.	Press Ice Maker.
Ice maker does not make ice.	Ice maker has just been installed.	You must wait for 12 hours for the refrigerator to make ice.
	Freezer temperature is too high.	Set the freezer temperature below -18 °C or -20 °C in warm ambient air.
	Dispenser panel Lock is activated.	Deactivate dispenser panel Lock.
	Ice maker is off	Turn on the ice maker
Ice does not dispense.	Ice may jam if the ice dispenser is not used for a long time (approx. 3 weeks)	If you won't be using the refrigerator for a long time, empty the ice bucket and turn off the ice maker.
	Ice bucket is not properly inserted.	Make sure the ice bucket is properly inserted.
	Water line is not connected properly or water supply is not on.	Check if the water line is installed correctly. Check if the water line stop cock is closed. 

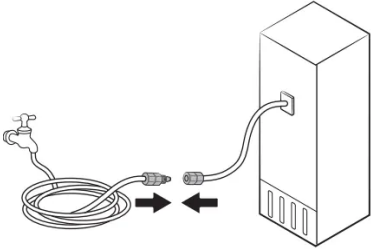
Water does not dispense.	Water line is not connected properly or water supply is not on.	<ul style="list-style-type: none"> <li>• Check if the water line is installed correctly. Check if the water line stop cock is closed.</li> </ul> 
	Dispenser panel Lock is activated.	Deactivate dispenser panel Lock.
	A third-party water filter was installed.	<ul style="list-style-type: none"> <li>• Use only Samsung-provided or approved filters.</li> <li>• Unapproved filters may leak and damage the refrigerator.</li> </ul>
	Water filter indicator turns on or blinks.	Replace the water filter. After replacing, reset the filter indicator sensor

### Do you hear abnormal sounds from the refrigerator?

Before calling for service, review the checkpoints below. Any service calls related to normal sounds will be charged to the user.

#### These sounds are normal.

- When starting or ending an operation, the refrigerator may make sounds similar to a car engine igniting. As the operation stabilizes, the sounds will decrease.

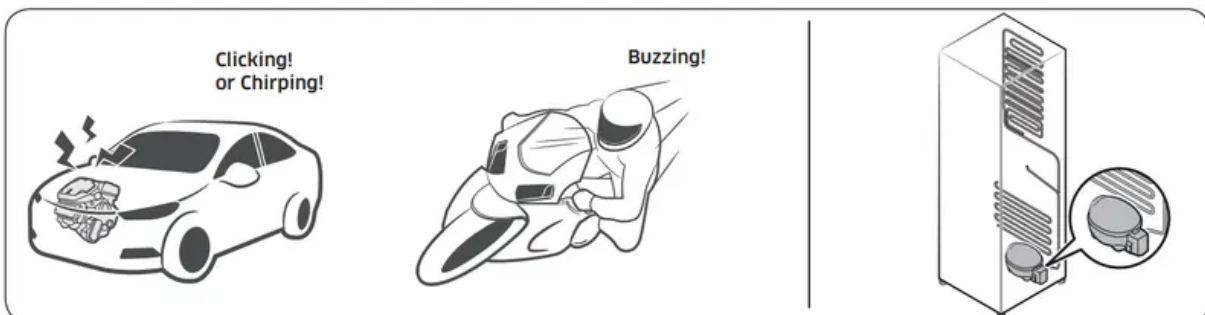

- While the fan is operating, these sounds may occur. When the refrigerator reaches the set temperature, no fan sound will occur.



- During a defrost cycle, water may drip on the defrost heater, causing sizzling sounds

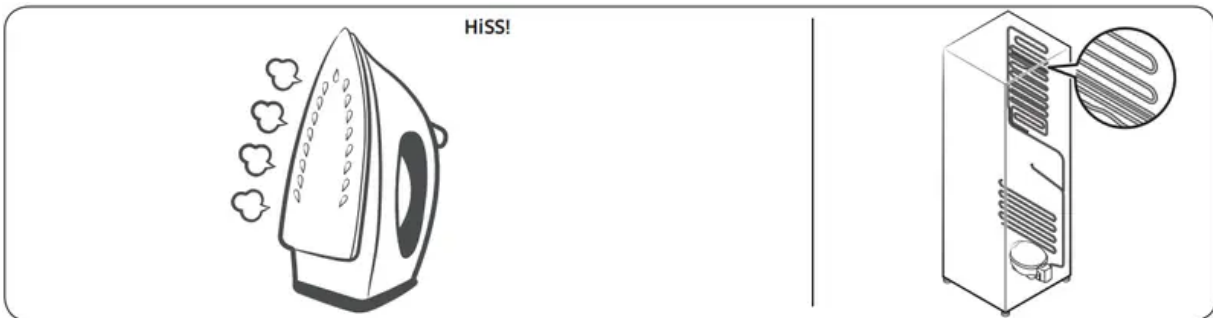

- As the refrigerator cools or freezes, refrigerant gas moves through sealed pipes, causing bubbling sounds.

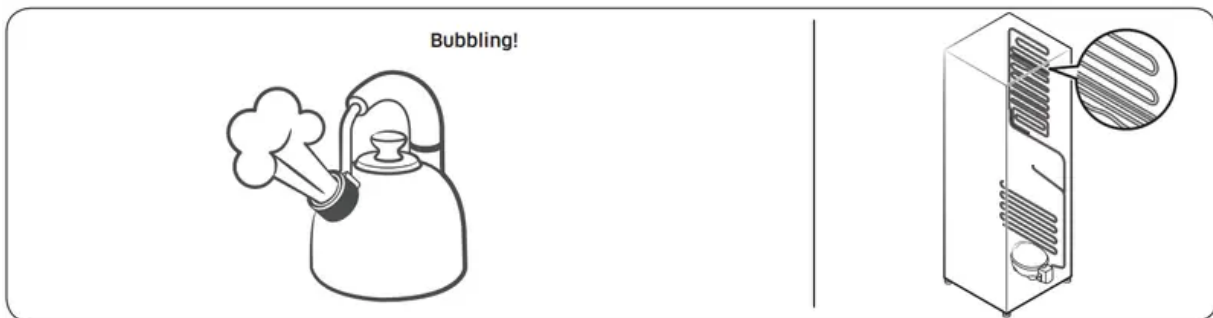

- As the refrigerator temperature increases or decreases, plastic parts contract and expand, creating knocking noises. These noises occur during the defrosting cycle or when electronic parts are working.

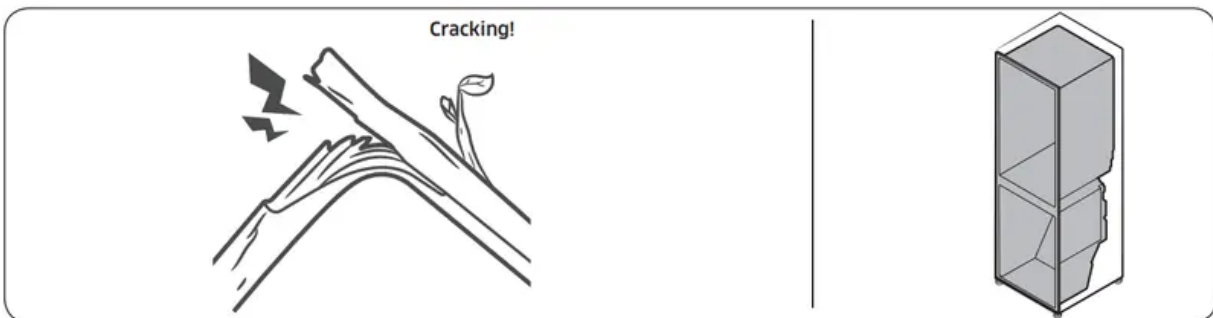

- For ice maker models: When the water valve opens to fill the ice maker, buzzing sounds may occur.

- Due to pressure equalizing when opening and closing the refrigerator door, whooshing sounds may occur.

## SmartThings

Symptom	Action
Could not find "SmartThings" in the app market.	The SmartThings app is designed for Android 6.0 (Marshmallow) or later, iOS 10.0 or later, iPhone 6 or later, and is optimized for Samsung smartphones (Galaxy S and Galaxy Note series).
The SmartThings app fails to operate.	<ul style="list-style-type: none"> <li>• The SmartThings app is available for applicable models only.</li> <li>• The old Samsung Smart Refrigerator app cannot connect with Samsung Smart Home models.</li> </ul>
The SmartThings app is installed but is not connected to my refrigerator.	<ul style="list-style-type: none"> <li>• You must log into your Samsung account to use the app.</li> <li>• Make sure that your router is operating normally.</li> <li>• If you have not connected your refrigerator to the SmartThings App after the app was installed, you must make the connection using the device registration function of the app.</li> </ul>
Could not log into the app.	<ul style="list-style-type: none"> <li>• You must log into your Samsung account to use the app.</li> <li>• If you don't have a Samsung account, follow the app's onscreen instructions to create one</li> </ul>
An error message appears when I try to register my refrigerator.	Easy Connection may fail due to the distance from your access point (AP) or electrical interference from the surrounding environment. Wait a moment and try again.
The SmartThings app is successfully connected to my refrigerator but does not run.	<ul style="list-style-type: none"> <li>• Exit and restart the SmartThings app or disconnect and reconnect the router.</li> <li>• Unplug the power cord of the refrigerator, and then plug it in again after 1 minute</li> </ul>

**Warning**

This content is compiled from multiple sources and is provided for reference purposes only. It may not be complete or fully applicable to all situations. If you are unable to resolve your issue, please contact the product manufacturer or an authorized service provider for official support.

---

Document generated by [ManualsFile](#)