

All about the Use & Care of your Microwave Oven

Features & Specifications

Microwave features

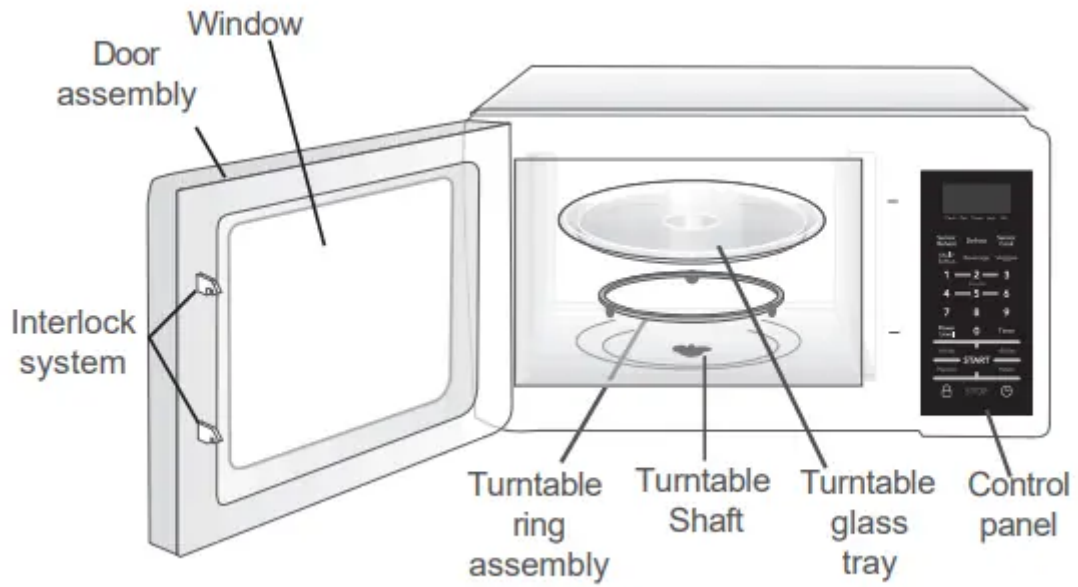

Control panel

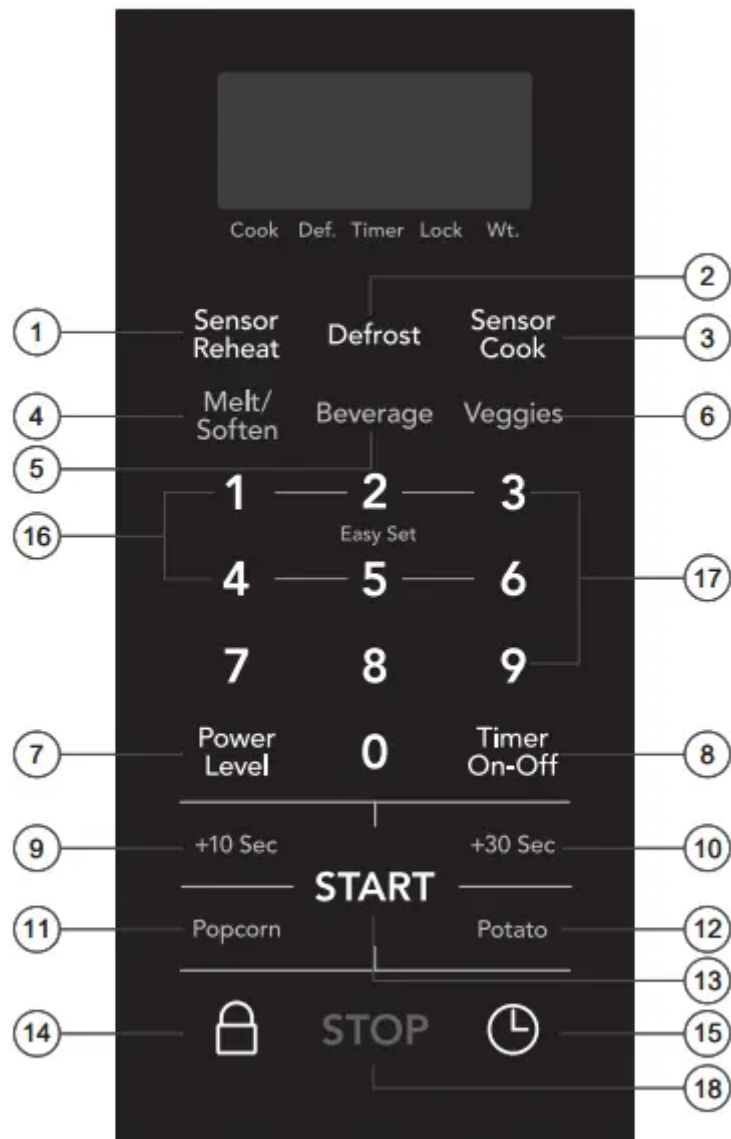

- (1) Sensor Reheat
- (2) Defrost
- (3) Sensor Cook
- (4) Melt/Soften
- (5) Beverage
- (6) Veggies
- (7) Power Level (10 power levels available)
- (8) Timer On-Off
- (9) +10 Sec
- (10) +30 Sec



- (11) Popcorn
- (12) Potato
- (13) START ~ Begin cooking time.
- (14) Safety Lock
- (15) Clock/Options
- (16) Easy Set (6 instant settings)
- (17) Number Pads (0-9)
- (18) STOP ~ Before cooking: clears all previous settings.

During cooking: press this pad once to pause cooking function, press this pad twice to cancel cooking and any other entries.

Before Operating

Learn more about your microwave oven

CAUTION

- To avoid risk of personal injury or property damage, do not operate the microwave oven empty.
- To avoid risk of personal injury or property damage, do not use stoneware, aluminum foil, metal utensils, or metal trimmed utensils in the microwave oven.

Setting the clock

The clock can be disabled when the microwave is first plugged in and the STOP pad is selected. To re-enable the clock follow clock instructions.

Example: setting clock display for 9:00:



1. Press Clock/Options pad.
2. Enter time using number pads.
3. Press START pad.

NOTE:

1. If you begin to enter in an incorrect time (e.g. 2:89) the 8 is an invalid digit and cannot be entered. Enter the correct time.

2. If you press STOP pad while setting the clock, the display will show the last time of day set.

Microwave utensil guide

Use

- Oven proof glass (specifically treated for high intensity heat): Utility dishes, loaf dishes, pie plates, cake plates, liquid measuring cups, casseroles and bowls without metallic trim.
- China: Bowls, cups, serving plates and platters without metallic trim.
- Plastic: Plastic wrap (as a cover) - lay the plastic wrap loosely over the dish and press it to the sides. Vent plastic wrap by turning back one edge slightly to allow excess steam to escape. The dish should be deep enough so that the plastic wrap will not touch the food. Use plastic dishes, cups, semirigid freezer containers and plastic bags for short cooking times. Use these with care because the plastic may soften from the heat of the food.
- Paper: Paper towels, waxed paper, paper napkins and paper plates with no metallic trim or design. Look for the manufacturer's label for any special instructions for use in the microwave oven.

Do not use

- Metal utensils: Metal shields the food from microwave energy and produces uneven cooking. Also, avoid metal skewers, thermometers or foil trays. Metal utensils can cause arcing, which can damage your microwave oven.
- Metal decoration: Bowls, cups, serving plates and platters without metallic trim.
- Aluminum foil: Avoid large sheets of aluminum foil because they hinder cooking and may cause harmful arcing. Use small pieces of foil to shield poultry legs and wings. Keep ALL aluminum foil at least 1 inch from the side walls of the oven cavity and door of the microwave.
- Wood: Wooden bowls and boards will dry out and may split or crack when you use them in the microwave oven. Baskets made of wood will react in the same way.
- Tightly covered utensils: Be sure to leave openings for steam to escape from covered cookware. Pierce plastic pouches of vegetables or other food items before cooking. Tightly closed pouches may explode.
- Brown paper: Avoid using brown paper bags. They absorb heat and can burn.
- Flawed or chipped cooking utensils: Any utensil that is cracked, flawed or chipped may break in the oven.
- Metal twist ties: Remove metal twist ties from plastic or paper bags. They become hot and could cause a fire.

Manual Operation

Setting the timer

Example: setting timer for 5 minutes

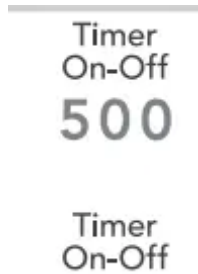

1. Press Timer On-Off pad once.
2. Enter desired time using number pads. (timer may be set up to 99 minutes and 99 seconds).
3. Press Timer On-Off pad. When finished, you will hear a series of beeps.

NOTE : Timer count down does not stop even if the door is open. To cancel the timer, press Timer On-Off pad once again

Safety Lock

- You may lock the control panel to prevent the microwave from being accidentally started or used by children.
- The safety lock feature is very useful when cleaning the control panel. The lock will prevent accidental programming when wiping the control panel.

Example: to set the safety lock ON:

- Press and hold the Safety Lock pad for more than 3 seconds. The lock chevron will appear in the display window with 1 beep.

**hold for 3
seconds**

Example: to change the safety lock from ON to OFF

**hold for 3
seconds**

Press and hold the Safety Lock pad for more than 3 seconds. The lock chevron will disappear in the display window with 1 beep.

Using Easy Set

1 2 3
4 5 6

- Microwave heating or cooking may be quickly set at 100% power level for 1, 2, 3, 4, 5 or 6 minutes. Use the number pads 1, 2, 3, 4, 5 or 6 to choose the desired minutes of cook time (this option will only work using the 1, 2, 3, 4, 5 or 6 numeric pads.)
- Example: to quickly heat for 2 minutes at 100% power: Press number pad for desired

minute(s). The microwave will start after 2 second delay **2**

- NOTE: "Food" will be displayed if a Easy Set cooking cycle or press +30 sec or +10 Sec pad is not selected within 5 minutes of placing food in the microwave. You must open then close the door again to clear "Food" from the display

Heating with high power level

Example: to heat for 5 minutes and 30 seconds at 100% power:

1. Use the number pads to enter desired heating time (cook time may be set up to 99

minutes and 99 seconds). **530** NOTE: For time sets that start with numbers 1 - 6, the remaining numbers must be entered within 2 second from the first pad press, otherwise the Easy Set time will be used.

- 2.

START

Press START pad.

When finished, you will hear a series of beeps

Heating with lower power levels Using the highest power level to heat foods does not always give the best results when some types of food need slower cooking, such as roasts, baked goods or custards. Your oven has nine other power levels you may choose.

Example: to heat for 4 minutes and 30 seconds at 70% power:

1. Use the number pads to enter desired heating time (cook time may be set up to 99 minutes and 99 seconds).

430

NOTE: For time sets that start with numbers 1 - 6, the remaining numbers must be entered within 2 second from the first pad press, otherwise the Easy Set time will be used.

Power
Level

START

2. Press Power Level pad 4 times more (70 % power). P-70 appears in the display
3. Press START pad.

When finished, you will hear a series of beeps.

Heating with multiple cooking stages

For best results, some microwave recipes call for different power levels or different lengths of time for cooking. Your microwave may be set to change from one stage to another automatically (2 stages maximum).

Example: to cook food at 80%power for 3 minutes and then 50% power for 6 minutes 30 seconds:

1. Use the number pads to enter desired heating time for the first stage (cook time may be set up to 99 minutes and 99 seconds).

300

NOTE: For time sets that start with numbers 1 - 6, the remaining numbers must be entered within 2 second from the first pad press, otherwise the Easy Set time will be used.

2. Press Power Level pad 3 times for power level 80 (80% power) for first stage. P-80 appears in the display.

Power
Level

3. Use the number pads to enter desired heating time for the second stage (cook time may be set up to 99 minutes and 99 seconds).

630

4. Press Power Level pad 6 times for power level 50 (50% power) for the second stage. P-50 appears in the display.

Power
Level

5. Press START pad.

START

When finished, you will hear a series of beep.

Press Power Level pad	Power level (Display)	Approximate Percentage of Power
once	P-HI	100%
twice	P-90	90%
3 times	P-80	80%
4 times	P-70	70%
5 times	P-60	60%
6 times	P-50	50%
7 times	P-40	40%
8 times	P-30	30%
9 times	P-20	20%
10 times	P-10	10%
11 times	P-00	0%

Adding cook time (+30 Sec)

- Pressing the +30 Sec pad once starts 30 seconds of cooking at a 100% power level. Pressing the +30 Sec pad during cooking adds 30 seconds (for each press) to the cook time..
- Example: to add 1 minute of cook time at the power level of 100%:
 1. Press +30 Sec pad 2 times.
- NOTE: "Food" will be displayed if a Easy Set cooking cycle or press +30 sec or +10 Sec pad is not selected within 5 minutes of placing food in the microwave. You must open then close the door again to clear "Food" from the display

Adding cook time (+10 Sec)

- Pressing the +10 Sec pad once starts 10 seconds of cooking at a 100% power level. Pressing the +10 Sec pad during cooking adds 10 seconds (for each press) to the cook time.
- Example: to add 20 seconds of cook time at the power level of 100%:
 1. Press +10 Sec pad 2 times.

- NOTE: "Food" will be displayed if a Easy Set cooking cycle or press +30 sec or +10 Sec pad is not selected within 5 minutes of placing food in the microwave. You must open then close the door again to clear "Food" from the display.

Setting Defrost by Weight

Example: to defrost 0.5 lbs. of food using the automatic defrost cycle (cook time determined automatically)

1. Press Defrost pad once. **Defrost**
2. Use the number pads to enter weight of food to defrost in pounds. You may enter weight from 0.5 to 7.0 pounds. (0.2 to 3.2 kg) **5**
3. **START**
Press START pad.

When finished, you will hear a series of beeps.

NOTE:

1. The weight amount must be a valid entry for this feature to start. A valid weight entry is 0.5 to 7.0 pounds A decimal point is assumed before the right-most digit. For example, enter 5 for 0.5 pounds and enter 50 for 5.0
2. The oven will beep during the Defrost cycle. At this time, open the door and turn, separate, or rearrange the food. Remove any portions that have thawed. Return frozen portions to the oven and press START pad to resume the defrost cycle.

Setting Defrost by Time

Example: to defrost food with the automatic defrost cycle for 5 minutes:

1. Press Defrost pad twice. **Defrost**
2. Use the number pads to enter desired defrost time (defrost time may be set up to 99 minutes and 99 seconds). **500**
3. **START**
Press START pad.

When finished, you will hear a series of beeps.

NOTE: The oven will beep during the Defrost cycle. At this time, open the door and turn, separate, or rearrange the food. Remove any portions that have thawed. Return frozen portions to the oven and press START pad to resume the defrost cycle.

Convenience Operation One Touch

Popcorn

CAUTION: DO NOT leave microwave oven unattended while popping corn

The popcorn feature lets you pop 3 different commercially packaged microwave popcorn sized bags. Use the table below to determine the setting to use: Amount

- 3.3 oz. : Press POPCORN pad 1
- 3.0 oz.: Press POPCORN pad 2
- 1.75 oz.: Press POPCORN pad 3

Example: to pop a 3.0 oz. bag of popcorn automatically:

1. Press POPCORN pad twice (refer to table above).
2. Press START pad.

When cooking is finished, you will hear a series of beeps

Important Information About Microwave Popcorn Feature:



- If / when the popcorn bag expands and no longer rotates properly, please press STOP pad once. Open the oven door and adjust the bag position to ensure even cooking. Close the oven door, press START pad to continue cooking.

Potato

The potato feature cooks 1, 2, or 3 potatoes automatically (cooking times based on 8 to 24 oz.).

Use the table below to determine the setting to use:

- 1 potato: Press POPCORN pad 1
- 2 potatoes: Press POPCORN pad 2
- 3 potatoes: Press POPCORN pad 3

Example: to cook 1 potato automatically.

1. Press POTATO pad (refer to table above).
2. Press START pad. When cooking is finished, you will hear a series of beeps.

NOTE:

- Before cooking, pierce potato with fork several times..

- After cooking, let potatoes stand for 5 minutes.

Beverage

The beverage feature can be used to cook 1,2 or 3 cups automatically. See the table for specific settings to use.

- 1 cup-8 oz. Press POPCORN pad 1
- 2 cups-16 oz. Press POPCORN pad 2
- 3 cups-24 oz. Press POPCORN pad 3

1. Press Beverage pad. (refer to table above)
2. Press START pad.

When finished, you will hear a series of beeps.

Convenience Operation Veggies

Fresh Vegetables

The fresh vegetables allow you to cook 4, 8 or 16 oz. vegetables. Use the table below to determine the setting to use.

- 1 cup-4oz. (default) : Numeric Pad 1
- 2 cups-8oz. Numeric Pad 2
- 3 cups-16oz. Numeric Pad 3

1. Press Veggies pad once. Fr-1 appears in the display.
2. Press numeric pad per the table. (If you are using the default amount, you may skip this step).
3. Press START pad.

When finished, you will hear a series of beeps

Frozen Vegetables

The frozen vegetables allow you to cook 4, 8 or 16 oz. vegetables. Use the table below to determine the setting to use.

- 1 cup-4oz. (default) Numeric Pad 1
- 2 cups-8oz. Numeric Pad 2
- 3 cups-16oz. Numeric Pad 3

1. Press Veggies pad twice. Fr-2 appears in the display.
2. Press the numeric pad per the table. (If you are using the default amount, you may skip this step).

3. Press START pad.

When finished, you will hear a series of beeps.

Convenience Operation Melt/Soften

Melt Butter

The butter feature allows you to melt butter that are 1 stick or 2 sticks. Use the table below to determine the setting to use:

- 1 cup-4oz. (default) Numeric Pad 1
- 2 cups-8oz. Numeric Pad 2
- 3 cups-16oz. Numeric Pad 3

1. Press Veggies pad once. Fr-1 appears in the display.
2. Press numeric pad per the table. (If you are using the default amount, you may skip this step).
3. Press START pad.

When finished, you will hear a series of beeps.

Frozen Vegetables

The frozen vegetables allow you to cook 4, 8 or 16 oz. vegetables. Use the table below to determine the setting to use.

- 1 cup-4oz. (default) Numeric Pad 1
- 2 cups-8oz. Numeric Pad 2
- 3 cups-16oz. Numeric Pad 3

1. Press Veggies pad twice. Fr-2 appears in the display.
2. Press the numeric pad per the table. (If you are using the default amount, you may skip this step).
3. Press START pad.

When finished, you will hear a series of beeps

Convenience Operation Melt/Soften

Melt Butter

The butter feature allows you to melt butter that are 1 stick or 2 sticks. Use the table below to determine the setting to use:

- 1 stick (default) Numeric Pad 1

- 2 sticks Numeric Pad 2

1. Press Melt/Soften pad once. So-1 appears in the display.
2. Press numeric pad per the table above. (If you are using the default amount, you may skip this step).
3. Press START pad.

When finished, you will hear a series of beeps.

Melt Chocolate

The chocolate feature allows you to melt chocolates that are 1, 2 or 3 servings .Use the table below to determine the setting to use:

- 1 serving-2 oz. (default) Numeric Pad 2
- 2 servings-4 oz. Numeric Pad 4
- 3 serving-8 oz. Numeric Pad 8

1. Press Melt/Soften pad twice. So-2 appears in the display
2. Press numeric pad per the table above. (If you are using the default amount, you may skip this step).
3. Press START pad.

When finished, you will hear a series of beeps.

Soften Ice Cream

The ice cream feature allows you to soften ice cream that are 1 pint or 1.5 quart. Use the table below to determine the setting to use:

- 1 pint (default): Numeric Pad 1
- 1.5 quart: Numeric Pad 15

1. Press Melt/Soften pad three times. So-3 appears in the display.
2. Press numeric pad per the table above. (If you are using the default amount, you may skip this step).
3. Press START pad.

When finished, you will hear a series of beeps.

Soften Cream Cheese

The cream cheese feature allows you to soften cream cheese that are 3 oz. or 8 oz. Use the table below to determine the setting to use:

- 3 oz. (default) Numeric Pad 3

- 8 oz. Numeric Pad 8

1. Press Melt/Soften pad 4 times. So-4 appears in the display.
2. Press numeric pad per the table above. (If you are using the default amount, you may skip this step).
3. Press START pad.

When finished, you will hear a series of beeps.

Sensor Operations

Sensor Cook Operating Tips

The Sensor Cook categories are designed to detect the increasing humidity released by the food during the cooking process. The microwave oven sensor will automatically adjust the cooking time to the type and amount of food. The food categories that are controlled with the humidity sensor are:

- Frozen Entree
- Meat
- Seafood

For best results, do not use one of the Sensor Cook categories twice in succession on the same food portion. This may result in severely overcooked or burnt food. If the food appears to be undercooked, use one of the Easy Set pads or cook time pads to add more time.

Additional sensor cook suggestions are:

- Never start with less than 4 oz. of food.
- Use proper containers and covers for best sensor cooking results.
- Always use microwave-safe containers and cover them with loose fitting lids or vented plastic wrap. Never use tight sealing plastic containers. They will prevent steam from escaping and this will mislead the sensor, usually causing the food to overcook.

Be sure the outside of the cooking containers and the cavity of the microwave oven are dry before placing food in the oven. Excessive moisture turning into steam that does not result from the food cooking can mislead the sensor.

Frozen Entree

The frozen entree sensor setting is designed for single frozen entree or frozen convenience foods such as frozen dinners from 8 to 32 oz. In size (starting with Frozen Entree temperature at 5°F).

1. Press Sensor Cook pad once. Sc-1 appears in the display.
2. Press START pad.

When finished, you will hear a series of beeps. If additional time is needed, continue cooking manually.

Notes:

- ALWAYS be sure to follow the directions that are spec for the microwave oven that is printed on the packaging for the food being prepared. Many times there are special instructions to follow in order to achieve best results.
- Be sure to allow for moisture to escape from the packaging. All frozen entree instructions specify that you poke holes in the film covering with a fork before cooking.
- Be careful when removing the film covers after cooking frozen convenience foods. Remove facing away from you to avoid steam burns.
- If the food is not done when the cook time is done finish cooking manually.

Meat (fresh)

The meat sensor setting cooks from 4 to 16 oz. of ground meat automatically (starting with meat temperature at 35-40 °F).

1. Press Sensor Cook pad 2 times. Sc-2 appears in the display.
2. Press START pad.

When finished, you will hear a series of beeps. If additional time is needed, continue cooking manually.

Notes:

- Break meat apart in glass bowl or container.
- Cover meat with lid or vented plastic wrap.
- Juices should be clear when finished cooking, then drain.
- About mid-way through the displayed cook time, press STOP pad to pause the cooking and mix; after mixing , press START to continue cooking with the remaining cook time displayed.

Seafood (fresh)

The seafood sensor setting cooks from 8 to 16 oz. of fish or seafood automatically (starting with a temperature at 35-40 °F).

1. Press Sensor Cook pad 3 times. Sc-3 appears in the display.
2. Press START pad.

When finished, you will hear a series of beeps. If additional time is needed, continue cooking manually.

Notes:

- Arrange fish in a single layer.
- Cover with lid or vented plastic wrap. Be sure to leave enough space in the venting or lid for steam to escape.
- About mid-way through the displayed cook time, press STOP pad to pause the cooking and turn over the fish; after turning, press START to continue cooking with the remaining cook time displayed.

Sensor Reheat

The sensor reheat feature is designed to detect the increasing humidity released by the food during the cooking process. The microwave oven sensor will automatically adjust the cooking time to the type and amount of food.

The food types to avoid using with the reheat feature are:

- Uncooked or raw foods.
- Bread and other dry types of food such as crackers, biscuits, or cakes.
- Beverages or frozen foods.
- Frozen pizza.

Notes concerning sensor reheat:

- For casseroles, add 2-3 tablespoons of liquid, cover with lid or vented plastic wrap.
- For canned foods, empty contents of can into a casserole dish or serving bowl. Cover dish with lid or vented plastic wrap. Let stand a few minutes before serving.
- For plates of food, arrange food on plate and add any butter or gravies, etc. Cover with loose-fitting lid or vented plastic wrap. After reheating, let stand a few minutes.

Example: to reheat (sensor) automatically:

1. Press Sensor Reheat pad once.
2. Press START pad. Sensor detects vapor emitting from food to determine cooking time.

Convenient Features

Clock & Options

The microwave oven has settings that allow you to customize the operation for your convenience. Below is the table showing the various settings. Press Clock & Options pad multiple times to the desired setting function.

- Clock/Options x 1
 - Option: Clock

- Clock/Options x 2
 - Option: Sound On/Off
- Clock/Options x 3
 - Option: Weight lb/kg
- Clock/Options x 4
 - Option: Power save
- Clock/Options x 5
 - Option: Demo

(1) Setting Clock

The clock can be disabled when the microwave is first plugged in and the STOP pad is selected. To re-enable the clock follow clock instructions.

Example: setting clock display for 9:00:



1. Press Clock/Options pad once.
2. Enter time using number pads.
3. Press START pad.

NOTE:

1. If you begin to enter in an incorrect time (e.g. 2:89) the 8 is an invalid digit and cannot be entered. Enter the correct time.
2. If you press STOP while setting the clock, the display will show the last time of day set.

(2) Turning Sound On/Of

Audible signals are available to guide you when setting and using your oven.

- A key press tone.
 - Three tones signal the end of a Kitchen Timer count down or end of a cooking cycle.
1. Press Clock/Options pad twice to turn Sound On/Off. oP-2 appears in the display.



2. Press START pad. oP-2 appears in the display during 2 seconds. Auto scroll every 2

START

seconds through on, oFF selection.

3. Press START pad to active displayed selection. Display selection for 2 seconds.

START

(3) Setting Weight Lb / Kg

Setting weight between pounds or kilograms.

1. Press Clock/Options pad 3 times to set weight Lb/Kg. oP-3 appears in the display.



2. Press START pad. oP-3 appears in the display during 2 seconds. Auto scroll every 2

START

seconds through lb, G (kg) selection.

3. Press START pad to active displayed selection. Display selection for 2 seconds.

START

(4) Setting Power Save On/Off

Turning ON power save turns off the time of day clock display.

1. Press Clock/Options pad 4 times to set Power Save On/Off. oP-4 appears in the display.



2. Press START pad. oP-4 appears in the display during 2 seconds. Auto scroll every 2

START

seconds through on, oFF selection.

3. Press START pad to active displayed selection. Display selection for 2 seconds.

START

(5) Setting Demo Mode On/Off

Suppose you want to enter Demo mode. When Demo is ON programming functions will work in a rapid countdown mode with no cooking power.

1. Press Clock/Options pad 5 times to set Demo Mode On/Off. oP-5 appears in the display.



2. Press START pad. oP-5 appears in the display during 2 seconds. Auto scroll every 2

START

seconds through on, oFF selection.

3. Press START pad to active displayed selection. Display selection for 2 seconds.

START

Cooking Charts

Defrosting tips

- When using the defrost weight feature, the weight entered should always be 0.5 to 6.5 pounds.
- Use both defrost weight and defrost time features for raw food items only. Defrosting gives best results when food to be thawed is a minimum of 0°F (taken directly from a true freezer). If the food has been stored in a refrigerator-freezer that does not maintain a temperature of 5° F or below, always program a lower food weight or lower cook time to prevent cooking the food.
- If the frozen food is stored outside the freezer for up to 20 minutes, enter a reduced cook time or weight.
- The shape of the package will alter the defrosting time. Shallow rectangular food packets defrost more quickly than a deep frozen block of food.
- Separate pieces as they begin to defrost. Separated frozen pieces of food defrost better.
- Shield warm areas of food with small pieces of foil if they start to become warm.
- You may use small pieces of aluminum foil to shield food items like chicken wings, leg tips and sh tails, but do not allow the foil to touch the oven cavity walls when defrosting.

Defrosting suggestions for meats

For best results, please read these suggestions when defrosting meats.

Meat

1. Roast beef or pork

- Normal amount: 2.5 to 6 lbs. (40 to 96 oz.)
 - Suggestions: Start with the food placed fat side down. After each stage, turn the food over and shield any warm portions with narrow strips of aluminum foil. Let stand, covered for 15-30 minutes.

2. Steaks, chops or fish

- Normal amount: 0.5 to 3 lbs. (8 to 48 oz.)
 - Suggestions: After each stage, rearrange the food. If there are any warm or thawed portions of food, shield them with narrow strips of aluminum foil. Remove any pieces of food that are nearly defrosted. Let stand, covered for about 5 to 10 minutes.

3. Ground meat

- Normal amount: 0.5 to 3 lbs. (8 to 48 oz.)
 - Suggestions: After each stage, remove any pieces of food that are nearly defrosted. Let stand, covered with foil for 5 to 10 minutes.

4. Whole chicken

- Normal amount: (40 to 96 oz.) 2.5 to 6 lbs.
 - Suggestions: Remove giblets before freezing poultry. Start defrosting with the breast side down. After the 1st stage, turn the chicken over and shield any warm portions with narrow strips of aluminum foil. After the 2nd stage, again shield any warm portions with narrow strips of aluminum foil. Let stand, covered, for 30 to 60 minutes in the refrigerator.

5. Chicken pieces

- Normal amount: 0.5 to 3 lbs. (8 to 48 oz.)
 - Suggestions: After each stage, rearrange or remove any pieces of food that are nearly defrosted. Let stand for 10-20 minutes.

Care & Cleaning

Cleaning suggestions

- For best performance and for safety reasons, keep the oven clean inside and outside. Take special care to keep the inner door panel and oven from frame free of food and grease build-up.

- Never use rough scouring powder or pads on the microwave. Wipe the microwave oven inside and out with a soft cloth and warm (not hot) mild detergent solution. Then rinse and wipe completely dry.
- Wipe spatters immediately with a wet paper towel, especially after cooking greasy foods like chicken or bacon. Clean your microwave oven weekly or more often, if needed.
- Follow these instructions to clean and care for your microwave oven:
 - Keep the inside (cavity) of the oven clean. Food particles and spilled liquids can stick to the oven walls, causing the oven to work less efficiently.
 - Wipe up spills immediately. Use a damp, clean cloth and mild soap. DO NOT use harsh detergents or abrasive cleaners.
 - To help loosen baked-on food particles or liquids, heat 2 cups of water (add the juice of 1 lemon if you desire to keep the oven fresh smelling) in a 4 cup measuring glass at High power for 5 minutes or until boiling. Let stand in oven cavity for 1 or 2 minutes.
 - Remove the glass turntable tray from the oven when cleaning the oven cavity or tray. To prevent the glass turntable from breaking, handle with care and do not put it in water immediately after cooking. Wash the turntable tray in warm sudsy water or in the dishwasher.
 - Your microwave oven (some models) may have a Stainless Steel finish or coating. Clean the stainless with warm soapy water using a clean sponge or cloth. Rinse with clean water and dry with a soft clean cloth. DO NOT use ANY store bought cleaners like Stainless Steel cleaners or any other types of cleaners containing any abrasive, chlorides, chlorines or ammonia. It is recommended to use mild dish soap and water or a 50/50 solution of water and vinegar. To prevent damage to the operating parts of the oven, do not let water seep into any vents or openings.
 - Care should be taken in cleaning the touch control panel. If the control panel becomes soiled, open the microwave oven door before cleaning. Wipe the panel with a cloth dampened slightly with water only. Dry with a soft cloth. Do not scrub or use any sort of chemical cleaners. Close door and touch STOP key.
 - Wash the oven door window with very mild soap and water. Be sure to use a soft clean cloth to avoid scratching.
 - If steam accumulates inside or outside the oven door, wipe with a soft cloth. Steam can accumulate when operating the oven in high humidity and in no way indicates microwave leakage.
 - Never operate the oven without food in the oven cavity; this can damage the magnetron tube or glass tray. You may wish to leave a cup of water standing

inside the oven when it is not in use to prevent damage if the oven is accidentally turned on.

Before You Call Solutions to Common Problems

Troubleshooting guide

If you have a problem you cannot solve, please do not hesitate to call our service line:

Questions or for Service Call:
1-800-374-4432

Before you call a repair person for your microwave, check the list below for possible easy solutions to some common problems.

Neither the microwave's display or oven operates

- Properly insert the plug into a grounded power outlet.
- Remove the plug from the outlet, wait 10 seconds, then plug the microwave in again.
- Reset the household circuit breaker or replace any blown fuses.
- Plug a different appliance into the power outlet. If the other appliance will not operate, have a qualified electrician repair the outlet.
- Plug the microwave into a different power outlet.

The oven display works, but the oven will not operate

- Make sure the oven door is closed securely and completely.
- Check to see if packing material or other materials are stuck to the door seal.
- Check for damage to the oven door.
- Press the STOP pad twice and attempt to re-enter cooking instructions.
- Plug a different appliance into the power outlet. If the other appliance will not operate, have a qualified electrician repair the outlet.
- Plug the microwave into a different power outlet.

The power goes off before the cook time has elapsed

- If there has been a power interruption, remove the plug from the outlet; wait 10 seconds, then plug the microwave in again. If there was a power outage, the time indicator in the display will show 00:00.
- Reset the clock and any cooking instructions.
- Reset the household circuit breaker or replace any blown fuses.

- Press the STOP pad twice and attempt to re-enter cooking instructions.
- Plug a different appliance into the power outlet. If the other appliance will not operate, have a qualified electrician repair the outlet.
- Plug the microwave into a different power outlet.

Food is cooking too slowly

- Make sure the oven is on a separate 20 amp circuit line. Operating another appliance on the same circuit can cause a voltage drop. If necessary, move the microwave to its own circuit.

You see sparks or arcing

- Remove any metallic utensils, cookware or metal ties from the oven cavity. If using aluminum foil, use only narrow strips and allow at least one inch between the foil and the interior oven walls.

The turntable makes noises or sticks

- Clean the turntable, roller ring and oven cavity bottom.
- Make sure the turntable and roller ring are positioned correctly.

Using your microwave causes TV or radio interference

- This is similar to the interference caused by other small appliances, such as hair dryers. Move your microwave further away from other appliances, like your TV or radio.

Warning

This content is compiled from multiple sources and is provided for reference purposes only. It may not be complete or fully applicable to all situations. If you are unable to resolve your issue, please contact the product manufacturer or an authorized service provider for official support.