

User manual RoboVac

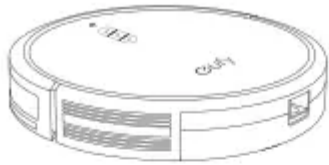

About Your RoboVac

What's in the Box



RoboVac

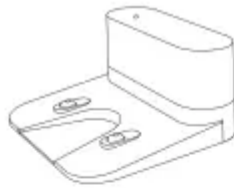

Charging Base



Power Adapter

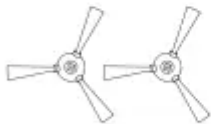

Side Brushes (x2)

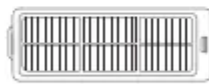

Additional Filter



Cleaning Tool



Cable Ties (x5)



Boundary Strips
6.6 ft/2 m Length
(x2)



Adhesive Tapes (x4)



Owner's Manual &
Other Documents

RoboVac Anatomy

A. Top & Side

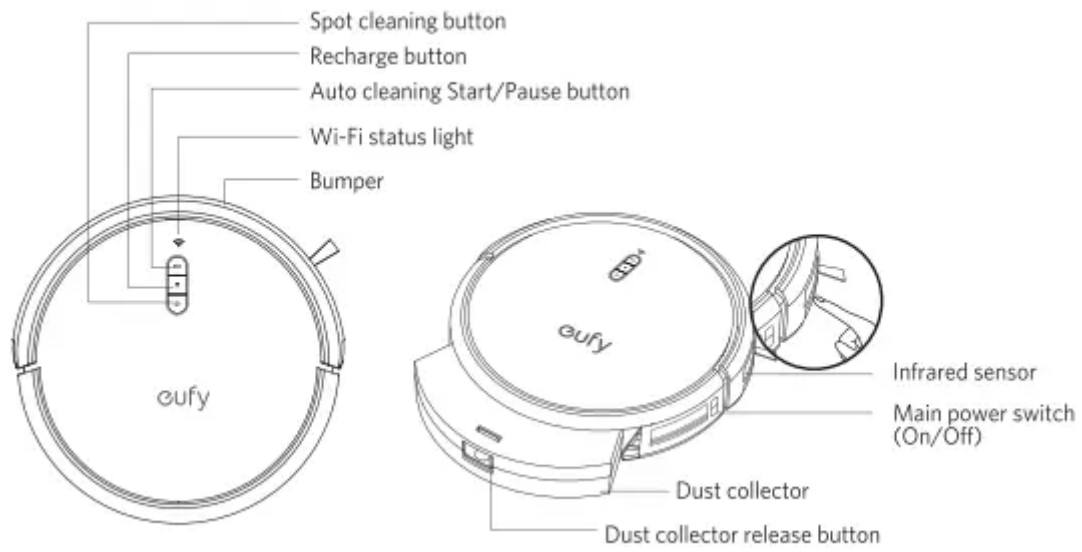

B. Bottom

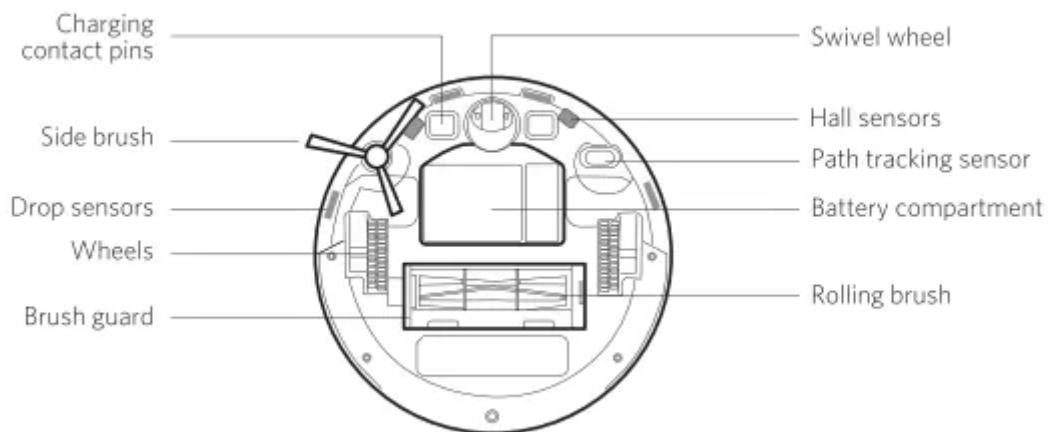

C. Dust Collector

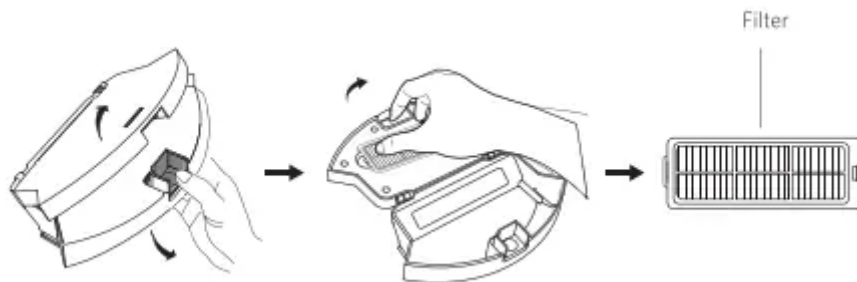

D. Suction Inlet



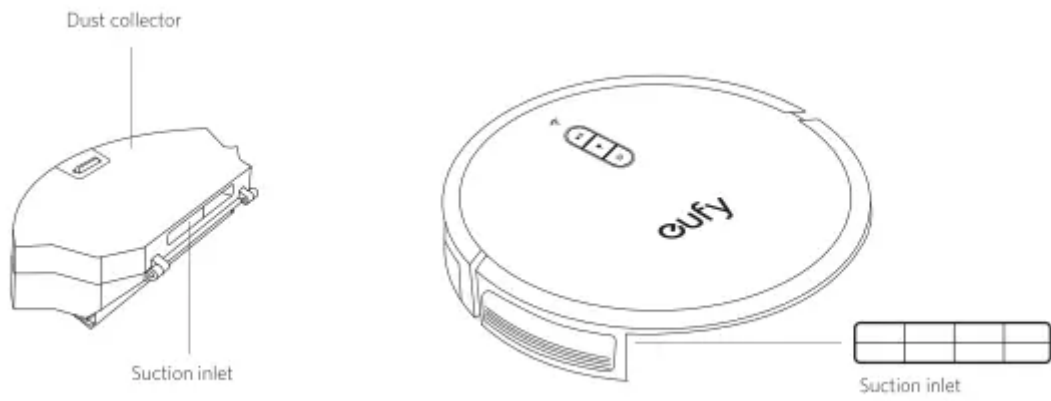

E. Charging Base

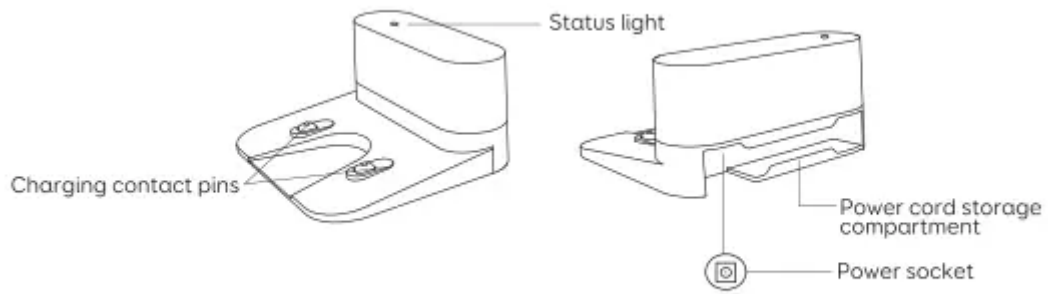

Buttons & Indicators



		<p>Start/Pause Cleaning</p> <ul style="list-style-type: none"> • Solid Blue: standby, cleaning, pause cleaning, returning to charging base or fully charged • Solid orange: standby or working in low battery status • Breathing orange (when docked to charging base): charging • Flashing red: error <p>* Refer to the "Troubleshooting>Voice Alert" section in this manual for solutions.</p> <p>Reset the Wi-Fi Connection (Press and hold for 10 seconds)</p>
		<p>Return to Charging Base</p> <ul style="list-style-type: none"> • Flashing blue slowly: returning to charging base • Solid blue: standby or paused
		<p>Spot Cleaning</p> <ul style="list-style-type: none"> • Flashing blue slowly: Spot Mode • Solid blue: standby or paused



- When you use the Find My Robot function via the EufyHome app, all three LED indicators are solid blue and a voice prompt is heard.
- To conserve power, the blue light on the ►|| button becomes dim when:
- RoboVac is not docked to the Charging Base and has been inactive for 10 minutes;
- RoboVac is fully charged for 1 minute.

(Wi-Fi Status Light)	Status
Slowly flashing blue	Waiting for connection
Rapidly flashing blue	Connecting with your wireless router
Solid blue	Connected to your wireless router

Using Your RoboVac

Important Tips Before Use

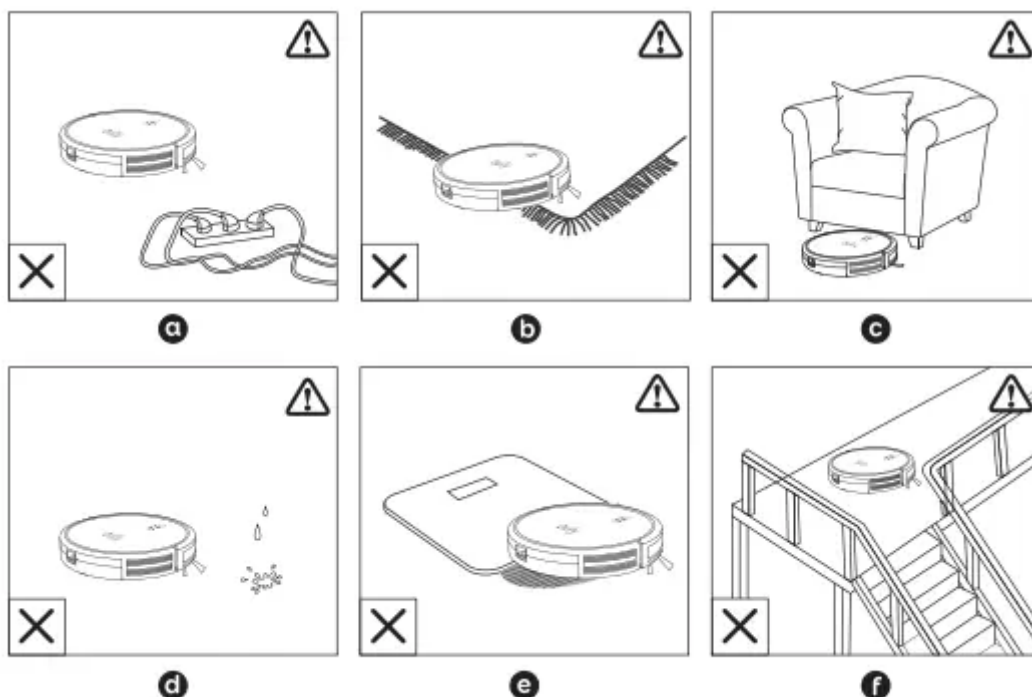

- a. Remove power cords and small objects from the floor that may entangle RoboVac. You can use the supplied cable ties to organize your wires and power cords.
- b. Fold tasseled edges of area rugs underneath to prevent tangling RoboVac. Avoid cleaning very dark-colored high-pile rugs or rugs thicker than 1.02 in/26 mm as they may cause RoboVac to malfunction.
- c. Keep RoboVac away from spaces lower than 2.87 in/73 mm to prevent RoboVac from getting stuck. If necessary, place a physical barrier to block off the problem areas.
- d. Keep RoboVac away from wet areas.
- e. RoboVac may climb on top of objects less than 0.63 in/16 mm in height. Remove these objects if possible.
- f. Anti-drop sensors will prevent RoboVac from tumbling down stairs and steep drops in most cases. Sensors are less effective if dirty or used on carpeted/reflective/very dark-colored floors. It is recommended to apply the Boundary Strip(s) to block off areas where RoboVac may fall.



Place physical barriers or Boundary Strips in front of fireplaces and areas that may cause damage to RoboVac if entered.

Preparation

- 1. Remove the foam blocks beside the bumper before use.
- 2. Install the side brush before use.

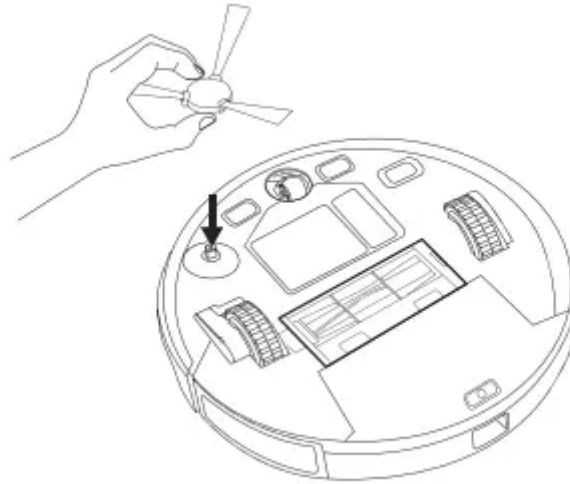

- 3. Turn on the main power switch at the right side of RoboVac.

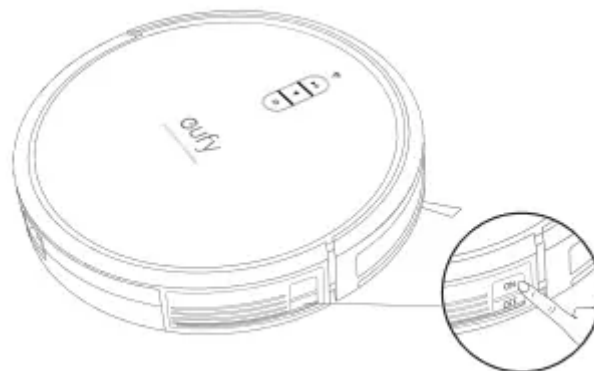

- 4. Place the Charging Base on a level surface and against a wall.

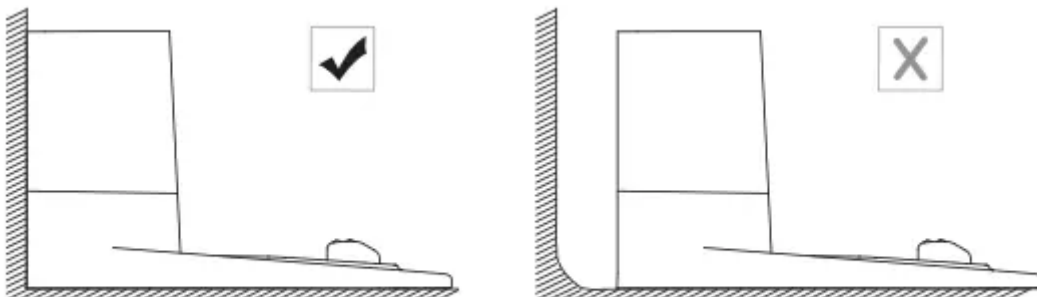

- 5. Remove objects within 3 ft/1 m of the left and right side and within 6 ft/2 m of the front of the Charging Base. If you cannot remove the objects, check whether RoboVac can return to the Charging Base normally; if not, contact eufy customer service for help.

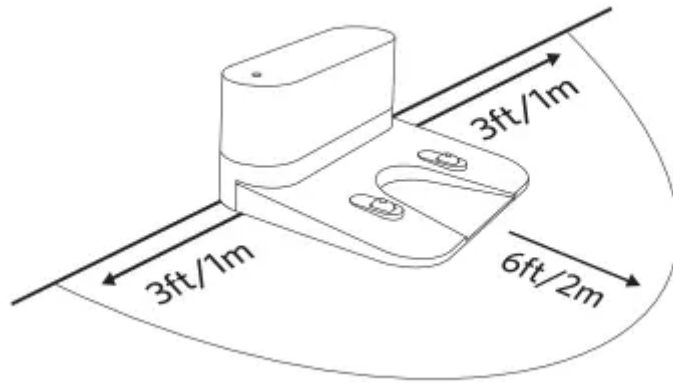

- 6. Connect the round connector of the adapter into the power socket on the Charging Base and the other end into a wall outlet.

When the Charging Base connects to AC power, the LED indicator on the Charging Base is SOLID WHITE.

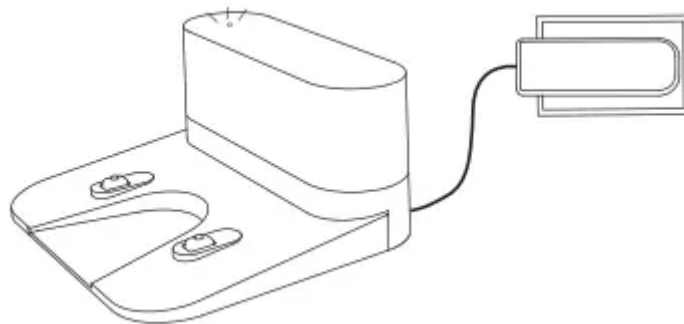



- Install the Charging Base in a location that RoboVac can easily access. It is recommended to place the Charging Base against a wall, and on a hard-level surface rather than on rugs or carpets.
- Always keep the Charging Base plugged in, otherwise RoboVac will not automatically return to it.

Charge Your RoboVac

- RoboVac has a pre-installed rechargeable battery that has to be fully charged before use.
- RoboVac returns to the Charging Base at the end of a cleaning cycle or when its battery is running low.

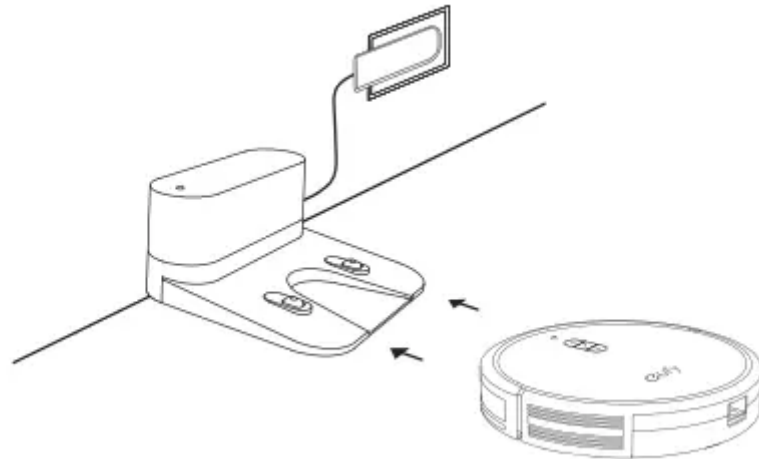
Method 1: Attach RoboVac to the Charging Base by aligning its charging pins with the charging pins on the base.



Method 2: Press  on the body to return RoboVac to the Charging Base.

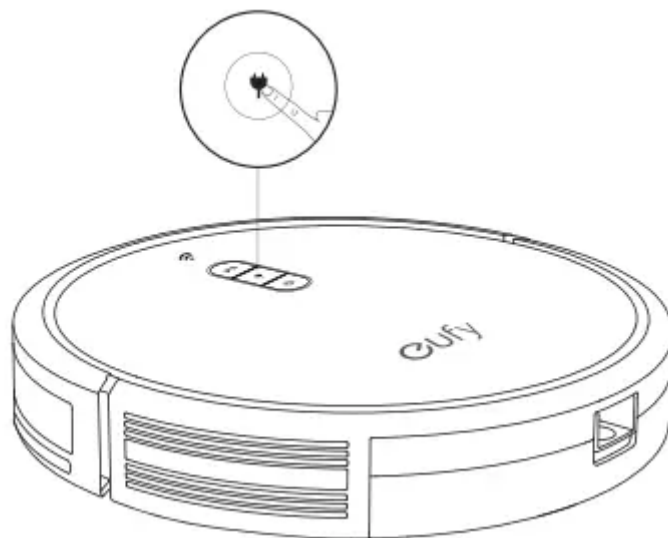

Turn off the main power switch if RoboVac will not be used for a long period of time. To preserve the battery's lifespan, recharge at least once every 6 months.

Use Your RoboVac with the EufyHome App

To enjoy all available features, it is recommended to control your RoboVac via the EufyHome app.

Before you start, make sure that:

- Your smartphone or tablet is connected to a Wi-Fi network.
- Your smartphone or tablet is running iOS 9.0 (or above) or Android 4.4 (or above).
- The 2.4GHz band wireless signal is enabled on your wireless router.

- The Wi-Fi status light on RoboVac is slowly flashing blue
- RoboVac is attached to the Charging Base to ensure it has enough power during setup.



1. Download the EufyHome app from the App Store (iOS devices) or Google Play (Android devices).
2. Open the app and create a user account.
3. Tap the "+" icon to add RoboVac to your EufyHome account.
4. Follow the instructions in the app to set up the Wi-Fi connection.
 - After connecting successfully. you can control RoboVac via the app.
 - With the app. you can select a cleaning mode. set the time. schedule a cleaning. view the system status. receive notifications and access additional features.

Wi-Fi Status Light

	Slowly flashing blue	Waiting for connection
	Rapidly flashing blue	Connecting with your wireless router
	Solid blue	Connected with your wireless router



- If you have any problems during the Wi-Fi setup process. refer to the “Troubleshooting > Wi-Fi connection” section in this Manual.
- If RoboVac gets stuck in any space. tap Find My Robot in the app to find the machine.

Restore Factory Settings

Press and hold  on RoboVac for 10 seconds to restore factory settings if necessary.

You will hear a voice prompt when the settings have been reset and the Wi-Fi status light will slowly flash blue. Now you can follow the Wi-Fi instructions in the Eufyhome app to set up the Wi-Fi connection.

Schedule Cleaning

With the EufyHome app, you can schedule RoboVac to start cleaning at a particular time.



You can set the time and customize the cleaning schedules from Sunday to Saturday on the EufyHome app. This function is available in the app only.

Start / Pause Cleaning



- Make sure the main power switch at the side of RoboVac is turned on before use.
- You can also start or pause cleaning via the EufyHome app.

1 Press  on RoboVac to start cleaning in Auto Mode

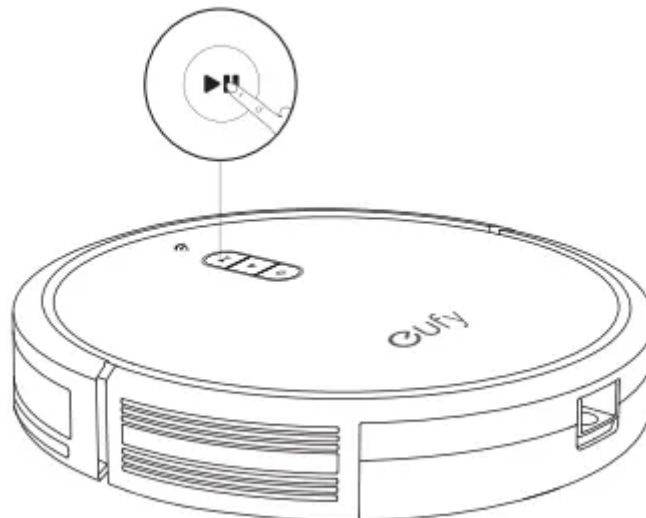



2 Press  again to pause cleaning.

Select a Cleaning Mode

Auto-cleaning

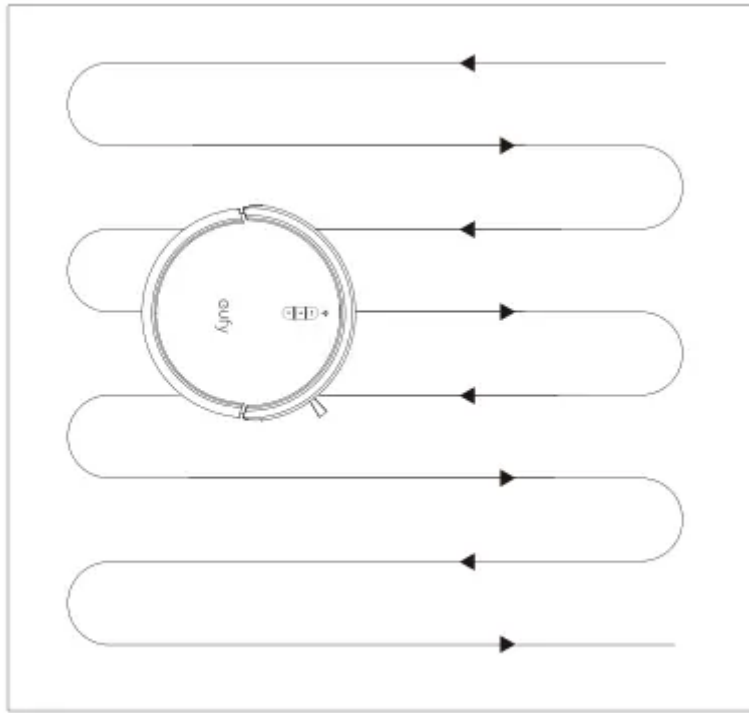
After startup, RoboVac moves from the Charging Base and automatically determines its cleaning route, following a bow-shaped cleaning method. When the entire clean is finished, RoboVac automatically returns to the Charging Base.



Press  on RoboVac to start cleaning in Auto Mode.



- In the EufyHome app, RoboVac can be set to return to the Charging Base automatically if the battery level becomes low. Once recharged, RoboVac will resume to finish the remaining cleaning.
- By default, RoboVac starts in Auto cleaning mode when it is turned on.

Spot cleaning

RoboVac intensively cleans a specific area in a spiral pattern. useful if there is a concentrated area of dust or debris. In Spot mode, RoboVac will stop cleaning after 2 minutes.

Press  on RoboVac to start cleaning in Spot Mode.

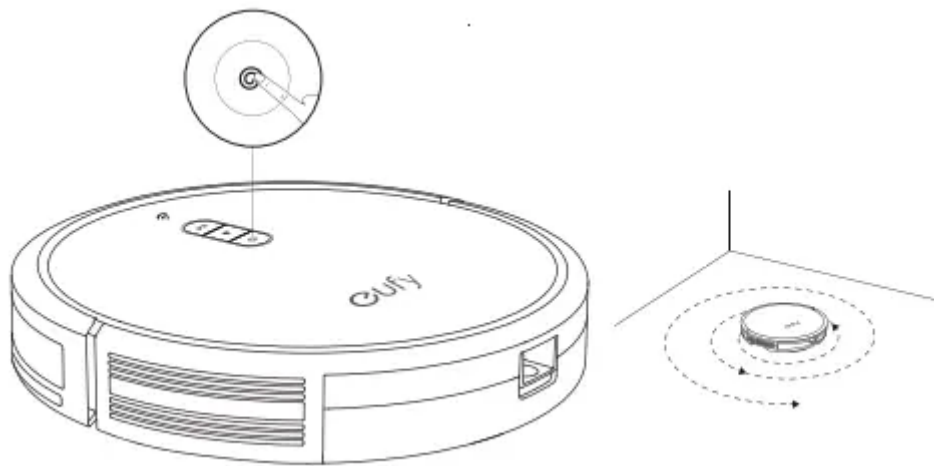

Select a Suction Power Level

In the EufyHome app, select a suction power level according to your needs

- Standard (Default)
- Turbo
- Max
- BoostIQ



When RoboVac starts cleaning the next time, it will clean according to the suction power level you previously selected.

Select BoostIQ feature

In the EufyHome app, select the BoostIQ feature according to your needs. While cleaning at standard suction power level, RoboVac will automatically increase the suction power if it detects that stronger power is needed to ensure the best clean BoostIQ is ideal for cleaning thicker carpets and hard-to-sweep messes, which will reduce the total cleaning time, but increase the noise level. If the vacuuming noise caused by BoostIQ disturbs you, you can disable this feature.

Use the Boundary Strip

With the Boundary Strip, you can keep RoboVac away from any area or item you do not want RoboVac to clean. RoboVac will recognize the Boundary Strip and will not cross into the blocked-off area.

1. Identify the area or item you do not want RoboVac to get close to.
2. If necessary, use scissors to cut the Boundary Strip to a shorter length. Be sure to correctly measure the length before cutting.

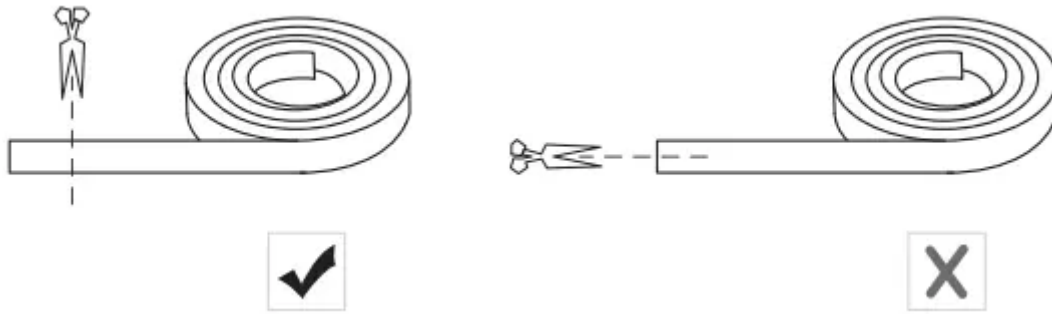

3. Apply the supplied strips of adhesive tape to lay the Boundary Strip flat on the floor. Make sure the strip is placed FLAT on the floor or under an area rug.

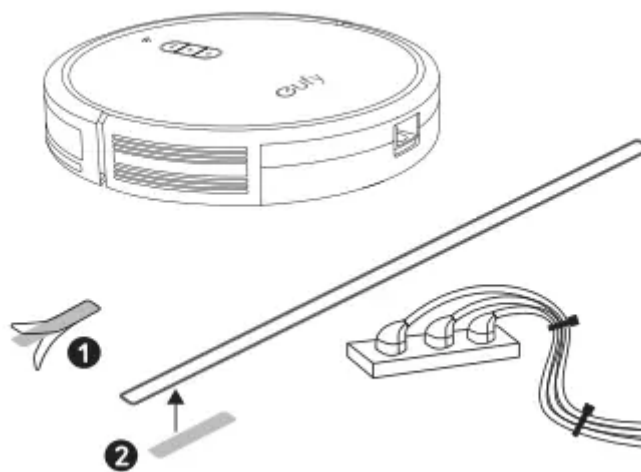

- If the Boundary Strip is rolled up, remove and then re-apply on the floor with adhesive tape. Otherwise the Boundary Strip may not work well.
- Make sure the Boundary Strip is placed on the same surface plane
- RoboVac is used on.
- Be careful not to damage the floor when using adhesive tape. It is not recommended for use on carpets.
- Keep the Boundary Strip away from objects that emit excessive heat.

Use Your RoboVac with Amazon Alexa / the Google Assistant

Amazon Alexa or the Google Assistant is a smart voice control device that enables you to control RoboVac with your voice.

Currently this feature only supports English, German, French, and Spanish. You could check regularly if more languages are supported at eufylife.com

Before you start. make sure that:

- RoboVac is attached to the Charging Base to ensure there is enough power.
- RoboVac is connected with the EufyHome app.
- You have an Amazon Alexa-enabled device (i.e. Amazon Echo, Echo Dot and Amazon Tap, Echo Show, Echo Spot) or a device enabled with the Google Assistant (i.e. Google Home, Google Home Mini). These devices are sold separately.
- The Amazon Alexa app or Google Home app is already installed on your smart device, and you have created an account.

To control RoboVac with Amazon Alexa or the Google Assistant

- 1. Open the EufyHome app and find “Smart integrations” in the top left.
- 2. Follow the on-screen instructions to complete the setup.

Cleaning and Maintenance

For optimal performance, follow the instructions below to clean and maintain RoboVac regularly. The cleaning/replacement frequency will depend on your usage habits of RoboVac.

Recommended cleaning/replacement frequency

RoboVac Part	Cleaning Frequency	Replacement Frequency
Dust Collector	After each use	-
Filter	Once every week (Twice a week if you have a pet)	Every 2 months
Side Brush	Once every month	Every 3-6 months (or when visibly worn)
Rolling Brush	Once every week	Every 6-12 months
Brush Guard	Once every month	Every 3-6 months (or when the silicone rubber strip on the brush guard becomes visibly worn)
Sensors	Once every month	-
Charging Pins	Once every month	-
Swivel Wheel	Once every month	-

Clean the Dust Collector and Filter

- 1 Press the dust collector release button to pull the dust collector out



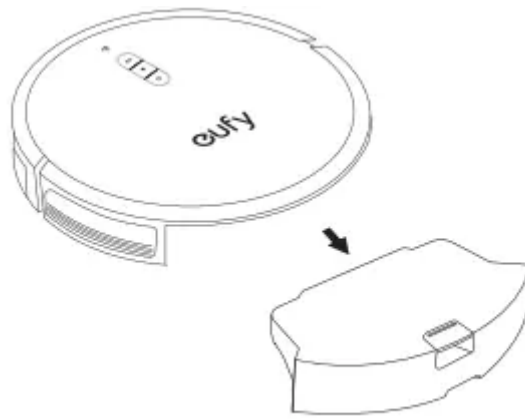

- 2 Open and empty the dust collector.

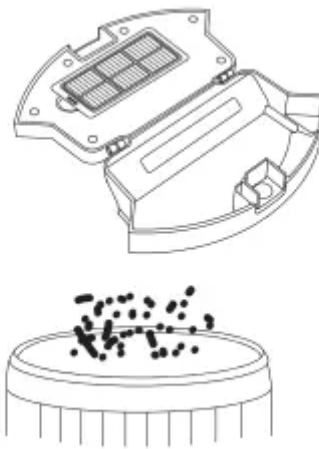

- 3 Remove the filter.

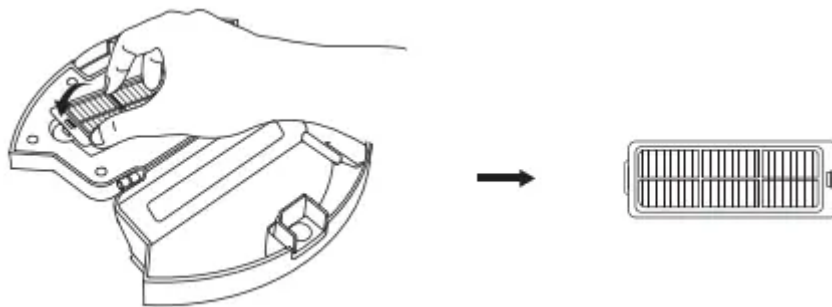

- 4 Tap the filter to remove dust



- 5 Place the filter back into the dust collector.

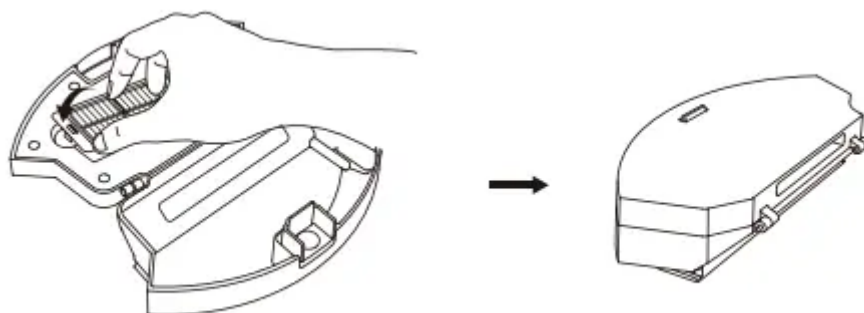

- 6 Push the dust collector back into the main unit.



Clean the Rolling Brush

1. Pull the release tabs to unlock the brush guard as shown.
2. Lift the rolling brush to remove.
3. Clean the rolling brush with the provided cleaning tool or a vacuum cleaner.
4. Reinstall the rolling brush by inserting the fixed protruding end first and then clicking it into place. e

5. Press down to snap the brush guard into place.

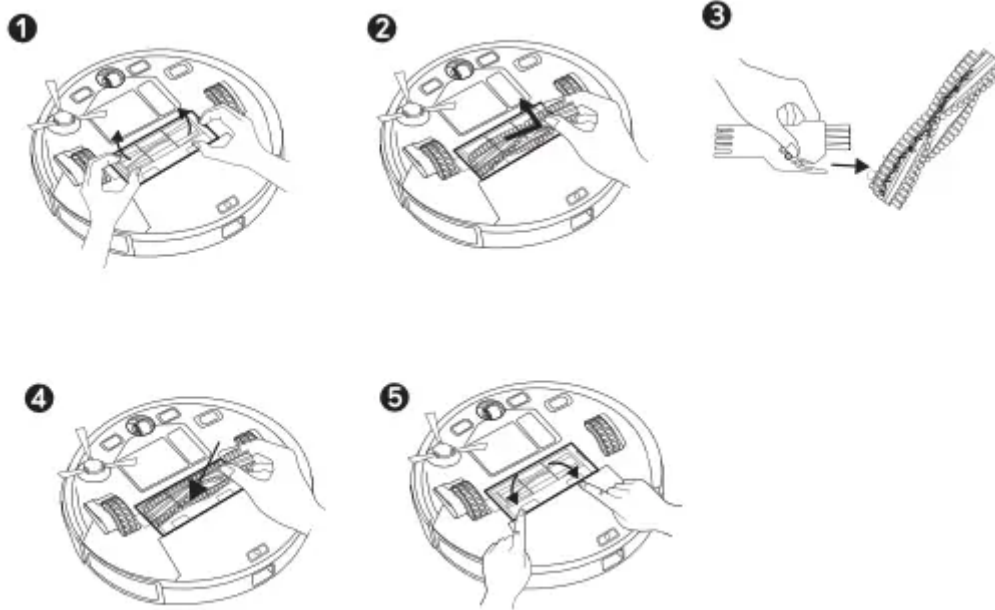

Clean the Side Brush

Foreign substances, such as hair, can easily get tangled in the side brush, and dirt may adhere to it. Be sure to clean it regularly.

- 1 Remove the side brush

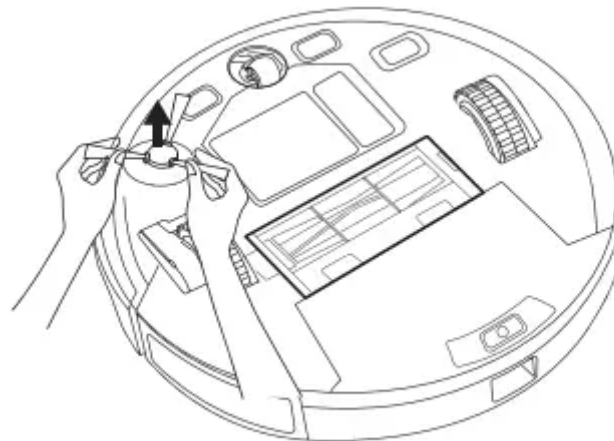

- 2 Carefully unwind and pull off any hair or string that is wrapped between the main unit and the side brush.
- 3 Use a cloth dampened with warm water to remove dust from the brush or to gently reshape it.

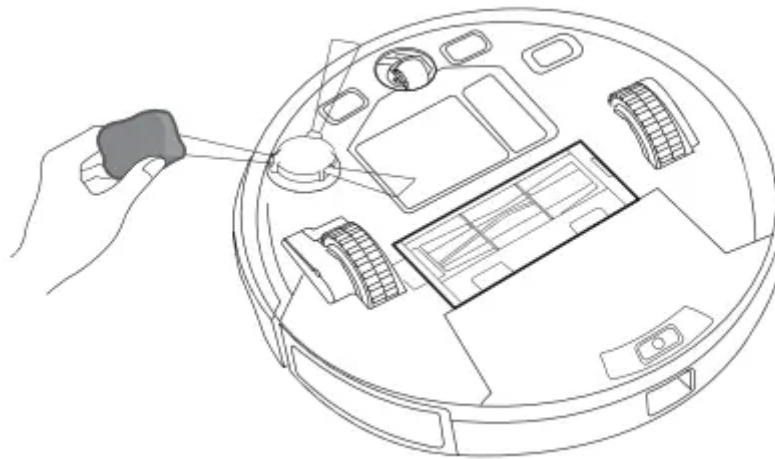

Only use the side brush when it is completely dry.

Replace the Side Brush

The side brush may become bent or damaged after being used for a period of time. Follow the instructions below to replace it

- Pull off the old side brush and snap the new one into place.

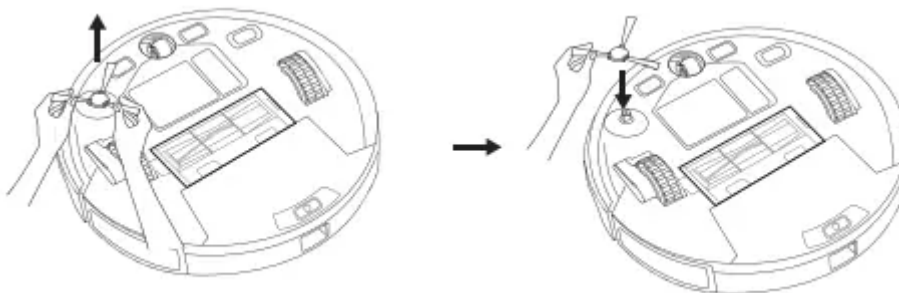

Clean the Sensors and Charging Pins

To maintain the best performance, clean the drop sensors, path tracking sensor and charging pins regularly.

- Dust off the sensors and charging contact pins using a cloth or cleaning brush

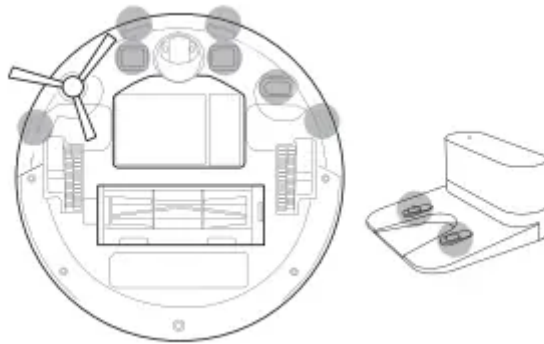

- Clean the path tracking sensor with a soft, dry cloth.

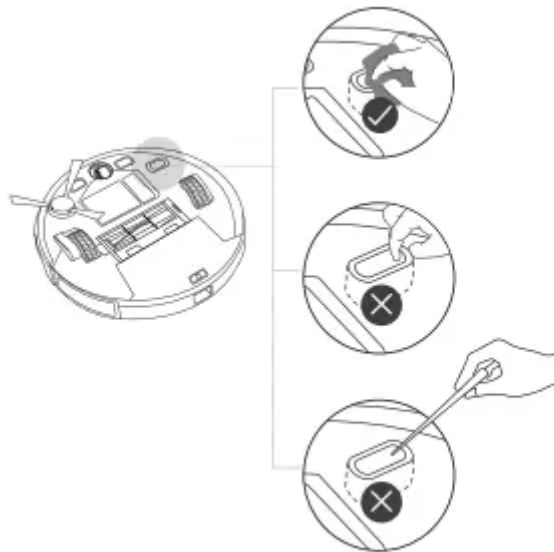

- Be careful not to make the path tracking sensor dirty by touching it with your hands.
- Do not clean the path tracking sensor with sharp-pointed objects, as it may damage the sensor.

Clean the Swivel Wheel

Hair or dust particles can easily get entangled in the swivel wheel. Be sure to clean the swivel wheel periodically and as needed.

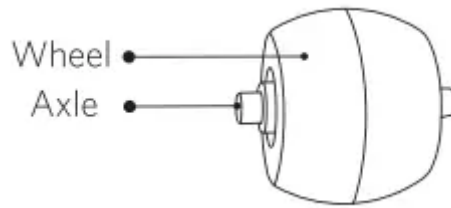

- 1 Remove the swivel wheel.

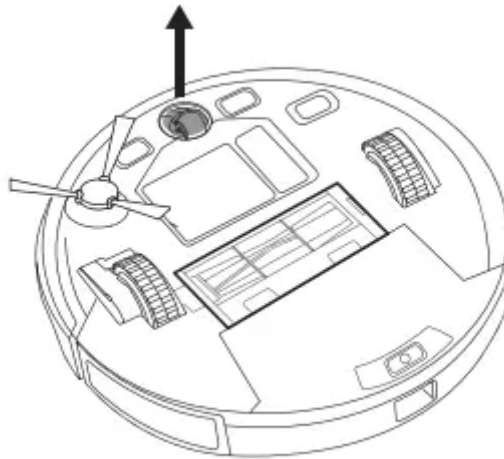

- 2 Clean any hair or debris wrapped around the wheel or entangled inside the wheel cavity.
- 3 Reinstall the wheel and push in until it clicks into place.



Do not clean the swivel wheel with water.

Troubleshooting

RoboVac cannot be activated.

- Make sure the main power switch is in the ON position.
- Make sure the battery is fully charged.
- If you still have trouble, turn off the main power switch and then turn it back on.

RoboVac stops working suddenly.

- Check if RoboVac is trapped or stuck on an obstacle.
- Check if the battery level is too low.
- If you still have trouble, turn off the main power switch, wait for 2 seconds, and then turn it back on.

You cannot schedule cleanings.

- Make sure the main power switch is turned on.
- Make sure the scheduled time has been set correctly.
- Check if RoboVac's power is too low to start cleaning.
- Cleaning schedules are erased when RoboVac is powered off or when reset to factory default settings. If RoboVac is powered on without Internet access, cleaning schedules will not synchronize and must be reset via the app.

Suction power is weak.

- Check if any obstructions are blocking the suction inlet.
- Empty the dust collector.
- Check if the filter is wet due to water or other liquid on the floor. Air-dry the filter completely before use.

RoboVac cannot be charged.

- Check if the indicator on the Charging Base lights up. If not, contact the eufy service center to repair or replace the Charging Base or power adapter.
- Dust off the charging contact pins with a dry cloth.
- Check if you can hear the "Charging" voice prompt when RoboVac is docked onto the Charging Base. If not, contact the eufy service center to repair or replace the Charging Base.

RoboVac cannot return to the Charging Base.

- Remove objects within 3 ft/1 m to the left and right side and within 6 ft/2 m of the front of the Charging Base.
- When RoboVac is in the vicinity of the Charging Base, it will return more quickly. However, if the Charging Base is located far away, RoboVac will need more time to return. Please be patient as it works its way back.
- Clean the charging contact pins.

RoboVac's movements or travel paths are abnormal.

- Clean the sensors carefully with a dry cloth.
- Restart RoboVac by turning the power switch off and on.

RoboVac's cleaning time becomes shorter or is less than 100 minutes.

- Make sure RoboVac is fully charged (indicated by a solid blue LED light) before cleaning.
- The cleaning time will be affected by the suction mode and floors/carpets to be cleaned:
- Standard suction mode (on hardwood floors): approx. 100 minutes of cleaning
- Turbo suction mode (on medium-pile carpets): approx. 60 minutes of cleaning

- Max suction mode (on medium-pile carpets): approx. 40 minutes of cleaning
- If your cleaning time is much less than the time mentioned above. contact eufy customer service for help

RoboVac cannot connect to a Wi-Fi network.

- Make sure you entered the Wi-Fi password correctly.
- Make sure your RoboVac, router, and mobile phone are close enough to ensure a strong signal strength.
- Make sure your Wi-Fi router supports the 2.4GHz and 802.11b/g/n bands; the 5GHz band is not supported. For details, refer to the “Troubleshooting > Wi-Fi connection” section in this manual.

You cannot control RoboVac with Amazon Alexa

- Check if there are any Internet connection problems.
- Check whether you have installed the Amazon Alexa app onto your smart device and enabled “EufyHome RoboVac” Skill in the Amazon Alexa app. For details, refer to the “Smart Integrations” page in the EufyHome App
- Make sure you have an EufyHome account and have connected to RoboVac.
- Make sure you are using correct Alexa voice-commands.

You cannot control RoboVac with the Google Assistant.

- Check if there are any Internet connection problems.
- Check if you have installed the Google Home app onto your smart device and initiated the “EufyHome” action in the Google Home app. For details, refer to the “Smart Integrations” page in the EufyHome App.
- Check if you are using the proper commands when talking to the Google Assistant. When making your request, first say the wake words “Ok Google”.
- Repeat your question. Speak clearly to the Google Assistant.

Voice Alert

When an error or issue occurs, the red indicator on RoboVac will flash and you will hear a specific voice prompt. Follow the voice prompt to solve the problem.

Error 1: Front bumper stuck

- Front bumper is stuck. Tap it repeatedly to remove any dust; if not, then move the device to a new position and try again.

Error 2: Wheel stuck. Check the wheel and move it to a new position

- Wheel may be stuck or trapped. Clear any obstacles in the surrounding area and check the wheel for any trapped dust. Move the device to a new position and try again

Error 4: Rolling brush stuck. Remove and clean the rolling brush

- Remove the rolling brush, roller joint, roller brush cover, and suction inlet to clean it. Once cleaned, place the items back into the device and try again.

Error 5: Device trapped. Clear the surrounding area

- Device is trapped. Clear any obstacles in the surrounding area and try again

Error 6: Device trapped. Place device near the position where the problem occurred.

- Device may be suspended in air. Move it to a new position close to the original position and try again. If the device is still unable to start, clean the edge sensor and try again.

Error 7: Wheel suspended. Please move the device to a new position

- Wheels may be suspended in air. Move the device to a flat surface and a new position close to the original position then try again

Error 8: Low battery. shutting down device. Please charge your device

- Low Battery; system will shut down. Charge the device and try again.

Error 9: Magnetic Boundary Strip detected. Move device to a different area

- Device is too close to a strong magnetic field or strip. Move the device to a different area and try again.

Error 21: Charging Base blocked by surrounding obstacles

- Charging base is blocked by obstacles. Clear any obstacles around the charging base and try again.

Error S1: Battery Error. Refer to Owner's Manual or App for help

- Open the battery compartment and check whether the battery is connected and restart the device
- Battery Temperature may be too high or low; wait until the battery falls to normal temperatures before usage (0 ° ~ 40° C/C 32° F to 104 ° F)
- If the issue persists, contact customer support for help

Error S2: Wheel Module Error. Refer to Owner's Manual or App for help

- Check whether the wheels are stuck or dust is trapped inside before restarting the device
- If the issue persists, contact customer support for help

Error S3: Side Brush Error. Refer to Owner's Manual or App for help

- Check whether the side brush is stuck in an unknown object before restarting the device
- If the issue persists, contact customer support for help

Error S4: Suction Fan Error. Refer to Owner's Manual or App for help

- Check whether the fan blades are stuck in an unknown object before restarting the device
- Clean the dust collector and filter before restarting the device
- If the issue persists, contact customer support for help

Error S5: Rolling Brush Error. Refer to Owner's Manual or App for help

- Remove and clean the roller brush, roller brush connection, roller brush cover and suction inlet before restarting the device
- If the issue persists, contact customer support for help

Error S8: Path Tracking Sensor Error. Refer to Owner's Manual or App for help

- Check and clean the path tracking sensor for unknown objects before restarting the device
- If the issue persists, contact customer support for help

Wi-Fi Connection

Before Wi-Fi setup, make sure RoboVac and your Wi-Fi network meet the following requirements.

Wi-Fi Setup Requirements

RoboVac:

- RoboVac is fully charged and the main power switch at the side of RoboVac is turned on.
- Wi-Fi status light slowly flashes blue.

Wi-Fi Network:

- Use the correct password for your network.
 - Do not use a VPN (Virtual Private Network) or Proxy Server.
 - Your Wi-Fi router supports 802.11b/g/n and IPv4 protocol
 - You are using a 2.4GHz router or a dual-band router that is configured to support a 2.4GHz frequency band. RoboVac does not support 5GHz frequency band.
- If RoboVac cannot connect to the Wi-Fi network and you are using a 2.4/5GHz mixed network, switch to a 2.4GHz network for Wi-Fi setup. You can switch back once your setup is complete.
- When connecting to a hidden network, make sure you enter the correct network name, SSID (case sensitive), and connecting to a 2.4GHz wireless network.
- When using a network extender/repeater, make sure the network name (SSID) and password are the same as your primary network.

- The firewall and port settings of your Wi-Fi router allow RoboVac to connect with the Eufy servers

Network Security Requirement

- WPA and WPA2 using TKIP, PSK, AES/CCMP encryption

Wi-Fi Channels

- The FCC requires that all wireless devices in the United States operate on the 1-11 wireless spectrum channels.
- Some countries outside North America can use spectrum channels higher than channel 11. Refer to your local regulatory agency to determine which channels are accessible.
- A future software release will support access to channels above 11 for users outside North America. Until then, use channels 1-11.

If you cannot control RoboVac with your smartphone, try the solutions below to solve the problem. If the problem persists, contact the Eufy service center for help.

Solid blue

RoboVac has connected to your router, but cannot access the Internet.

- Check if your router is connected to the Internet.
- Check with your Internet provider to see if there is any Internet connection problem.

Rapidly flashing blue

RoboVac cannot connect to your wireless router.

- Check if you have modified your network name and password.
- Reset Wi-Fi connection if necessary. Refer to the "Use Your RoboVac with the EufyHome App > Restore Factory Settings" section in this manual

Slowly flashing blue

Wi-Fi connection is reset or has not been set up before.

- Set up Wi-Fi connection with RoboVac. Refer to the "Use Your RoboVac with the EufyHome App" section in this manual
- Reset Wi-Fi connection if necessary. Refer to the "Use Your RoboVac with the EufyHome App > Restore Factory Settings" section in this manual.

Off

+ RoboVac is turned off.

+ RoboVac's power level is low.

+ RoboVac is in Sleep mode

- Charge RoboVac by attaching it to the Charging Base. Make sure the main power switch is turned on.

Warning

This content is compiled from multiple sources and is provided for reference purposes only. It may not be complete or fully applicable to all situations. If you are unable to resolve your issue, please contact the product manufacturer or an authorized service provider for official support.

Document generated by [ManualsFile](#)

