

PRODUCT OVERVIEW

Front Panel / Right Side Panel of the Soundbar

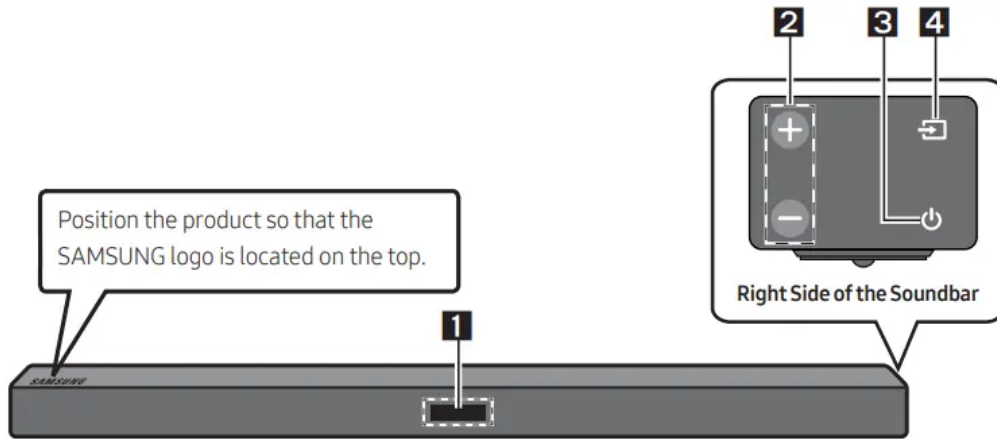

1. Display: Displays the product's status and current mode.
2. +/- (Volume) Button: Adjusts the volume.
 - When adjusted, the volume level appears on the Soundbar's front display
3. (Power) Button: Turns the power on and off.
4. (Source) Button: Selects the source input mode

Input mode	Display
Optical Digital input	D.IN
AUX input	AUX
BLUETOOTH mode	BT
USB mode	USB

- To turn on "BT PAIRING" mode, change the source to "BT" mode, and then press and hold the (Source) button for more than 5 seconds.

When you plug in the AC cord, the power button will begin working in 4 to 6 seconds.

When you turn on this unit, there will be a 4 to 5 second delay before it produces sound.

If you want to enjoy sound only from the Soundbar, you must turn off the TV's speakers in the Audio Setup menu of your TV. Refer to the owner's manual supplied with your TV.

Bottom Panel of the Soundbar

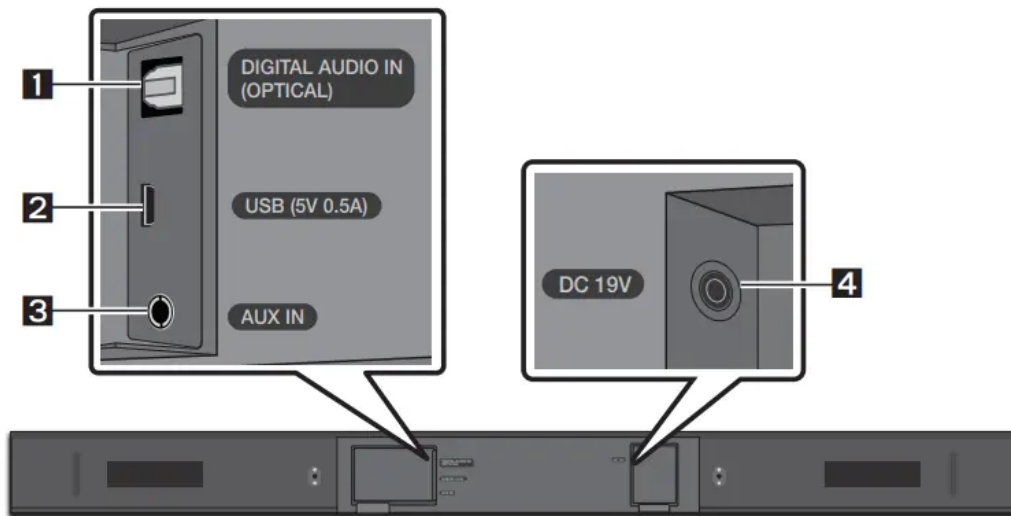

1	DIGITAL AUDIO IN (OPTICAL) Connect to the digital (optical) output of an external device.
2	USB (5V 0.5A) Connect a USB device here to play music files on the USB device through the Soundbar.
3	AUX IN Connect to the Analog output of an external device.
4	DC 19V (Power Supply In) Connect the AC/DC power adaptor.

When disconnecting the power cable of the AC/DC power adaptor from a wall outlet, pull the plug.
Do not pull the cable.

Do not connect this unit or other components to an AC outlet until all connections between components are complete

CONNECTING THE SOUNDBAR

Connecting Electrical Power

Use the power components (1, 2) to connect the units to electrical outlets in the following order: 1.) Subwoofer → 2.) Soundbar Main Unit. See the illustrations below.

- For more information about the required electrical power and power consumption, refer to the label attached to the product. (Label : Bottom of the Soundbar Main Unit)

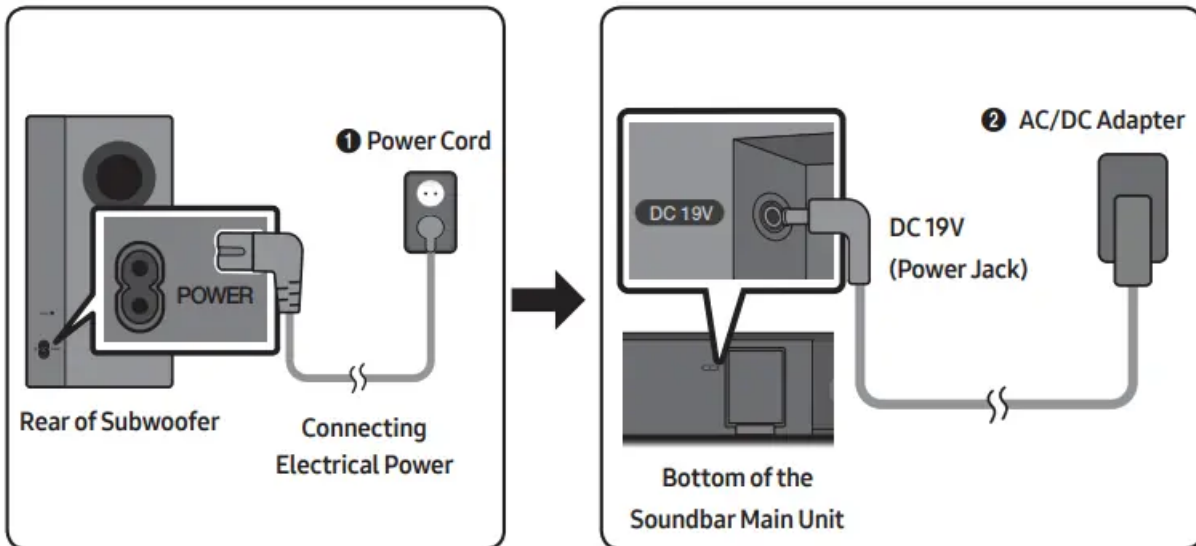

Connecting the Soundbar to the Subwoofer

- When the subwoofer is connected, you can enjoy rich bass sound.

Automatic connection between the Subwoofer and the Soundbar

- When you turn the power on after connecting the power cables to the Soundbar and subwoofer, the subwoofer is automatically connected to the Soundbar.
 - When auto pairing is complete, the blue indicator at the rear of the subwoofer turn on.

LED Indicator Lights on the Rear of Subwoofer

LED	Status	Description	Resolution
Blue	On	Successfully connected (normal operation)	-
	Blinking	Recovering the connection	Check if the power cable to the main Soundbar unit is connected properly or wait for a while. (If blinking persists, try manually connecting the subwoofer. See page 7.)
Red	On	Standby (with the Soundbar main unit turned off)	Check if the power cable to the main Soundbar unit is connected properly.
		Connection failed	Connect again. See the instructions for manual connection on page 7.
Red and blue	Blinking	Malfunction	See the contact information for the Samsung Service Center in the manual.

Manually connecting the Subwoofer if automatic connection fails

Check before performing the manual connection

- Check whether the power cables for the Soundbar and subwoofer are connected properly.
1. Make sure that the Soundbar is turned on. Press and hold ID SET on the rear of the subwoofer for at least 5 seconds. The red indicator on the rear of the subwoofer turns off

and the blue indicator blinks.

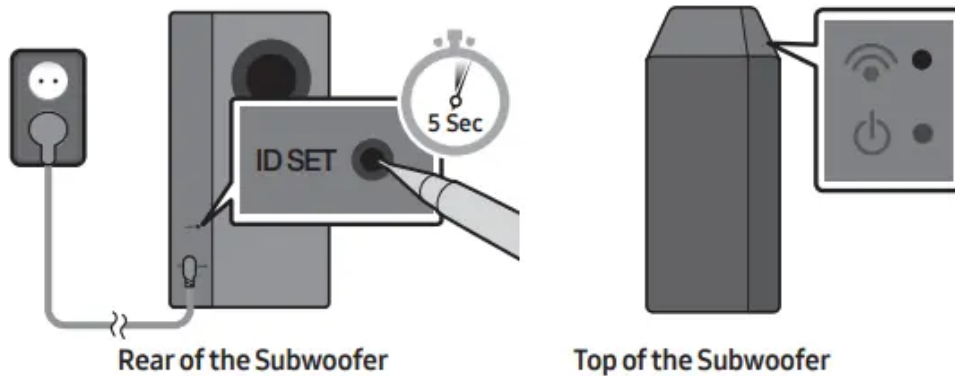

2. Turn off the Soundbar.
3. Press and hold the VOL button on the remote control for at least 5 seconds with the Soundbar turned off (OFF).
4. The ID SET message appears on the display of the Soundbar for 1.3 seconds, and then disappear

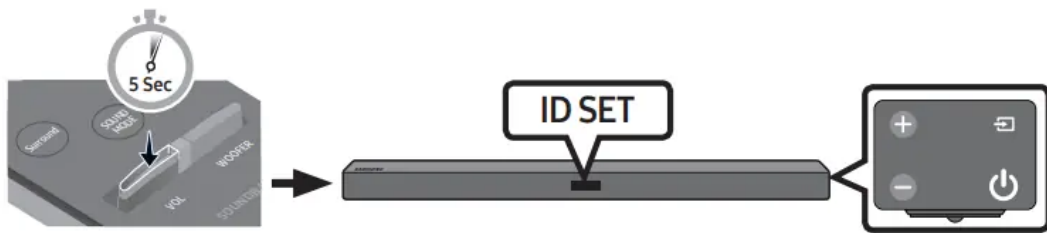

5. When the blue indicator on the subwoofer blinks, turn on the Soundbar's power by pressing  (Power) button on the right side of the main unit or on the remote control.
6. When the connection is successfully established, the blue indicator on the top of the subwoofer stops blinking and glows continuously.
 - If the connection process fails, the blue indicator will flash continuously. Go to Step 1 and start again.

CONNECTING TO YOUR TV

Hear TV sound from your Soundbar through wired or wireless connections.

- When the Soundbar is connected to selected Samsung TVs, the Soundbar can be controlled using the TV's remote control.
 - When using optical cable, this feature can be supported by 2017 Samsung Smart TVs that support Bluetooth.
 - This function also allows you to use the TV menu to adjust the sound field and various settings as well as the volume and mute

Method 1. Connecting with a Cable

Connecting using an Optical Cable

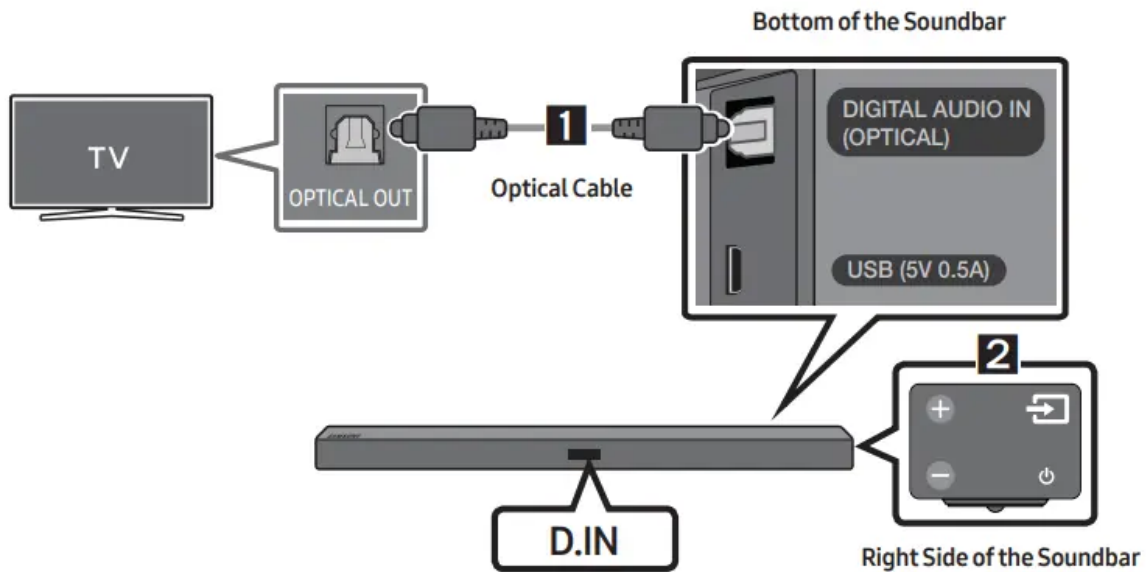

1. Connect the DIGITAL AUDIO IN (OPTICAL) port on the Soundbar to the OPTICAL OUT port of the TV with a digital Optical Cable
2. Press the (Source) button on the top panel or remote control, and then select the “D.IN” mode.
 - When the Soundbar is connected to a Samsung smart TV released in 2017 or later, the Bluetooth POWER function automatically turns on to enable the Soundbar to be controlled with the TV remote control. (See page 21 for details on Bluetooth POWER.)

Auto Power Link

Auto Power Link automatically turns on the Soundbar when the TV is turned on.

1. Connect the Soundbar and a TV with a digital optical cable.
2. Press the (Source) button on the right side panel or on the remote control, and then select “D.IN”.
3. Press the Left button on the remote control for 5 seconds to turn Auto Power Link on or off.
 - Auto Power Link is set to ON by default. (To turn off this function, turn off Auto Power using the Soundbar.)
 - Depending on the connected device, Auto Power Link may not function.
 - This function is only available in the “D.IN” mode.



Method 2. Connecting Wirelessly

Connecting a TV via Bluetooth

When a TV is connected using Bluetooth, you can hear stereo sound without the hassle of cabling.

- Only one TV can be connected at a time.



The initial connection

1. Press the (Source) button on the right side panel or on the remote control, and then select “BT”.
2. Change “BT” to “BT PAIRING”.
 - If “BT READY” appears, press and hold the (Source) button on the right side panel of the Soundbar or on the remote control for more than 5 seconds to display “BT PAIRING”.
3. Select Bluetooth mode on the TV. (For more information, see the TV’s manual.)
4. Select “[AV] Samsung Soundbar Mxxx M-Series” from the list on TV’s screen. An available Soundbar is indicated with “Need Pairing” or “Paired” on the TV Bluetooth device list. To connect to the Soundbar, select the message and establish a connection.
 - When the TV is connected, [TV Name] → “BT” appears on the Soundbar’s front display.
5. You can now hear TV sound from the Soundbar.

If the device fails to connect

- If the previously connected Soundbar listing (e.g. “[AV] Samsung Soundbar Mxxx M-Series”) appears in the list, delete it.
- In “BT” mode, press and hold the (Source) button for more than 5 seconds on the right side panel of the Soundbar or on the remote control to switch to “BT PAIRING” mode. Then, select “[AV] Samsung Soundbar Mxxx M-Series” from the TV’s search list.

What is the difference between BT READY and BT PAIRING?

- BT READY : In this mode, you can search for previously connected TVs or connect a previously connected mobile device to the Soundbar.
- BT PAIRING : : In this mode, you can connect to a new device. (While in “BT” mode, press and hold the (Source) button for more than 5 seconds on the right side of the Soundbar or on the remote control.)

NOTES

- If asked for a PIN code when connecting a Bluetooth device, enter <0000>.
- In Bluetooth connection mode, the Bluetooth connection will be lost if the distance between the Soundbar and the Bluetooth device exceeds 10 meters.
- The Soundbar automatically turns off after 5 minutes in the Ready state.
- The Soundbar may not perform Bluetooth search or connection correctly under the following circumstances:
 - If there is a strong electrical field around the Soundbar.
 - If several Bluetooth devices are simultaneously paired with the Soundbar.
 - If the Bluetooth device is turned off, not in place, or malfunctions.
- Electronic devices may cause radio interference. Devices that generate electromagnetic waves must be kept away from the Soundbar main unit - e.g., microwaves, wireless LAN devices, etc

Disconnecting the Soundbar from the TV

Press the (Source) button on the right side panel or on the remote control and switch to any mode but “BT”.

- Disconnecting takes time because the TV must receive a response from the Soundbar. (The time required may differ, depending on the TV model.)
- To cancel automatic Bluetooth connection between the Soundbar and TV, press the  (Play/Pause) button on the remote control for 5 seconds in “BT READY” status. (Toggle On → Off)

CONNECTING AN EXTERNAL DEVICE

Connect to an external device via a wired connection or Bluetooth connection to play the external device's sound through the Soundbar.

Connecting using an Optical or Analog Audio (AUX) Cable

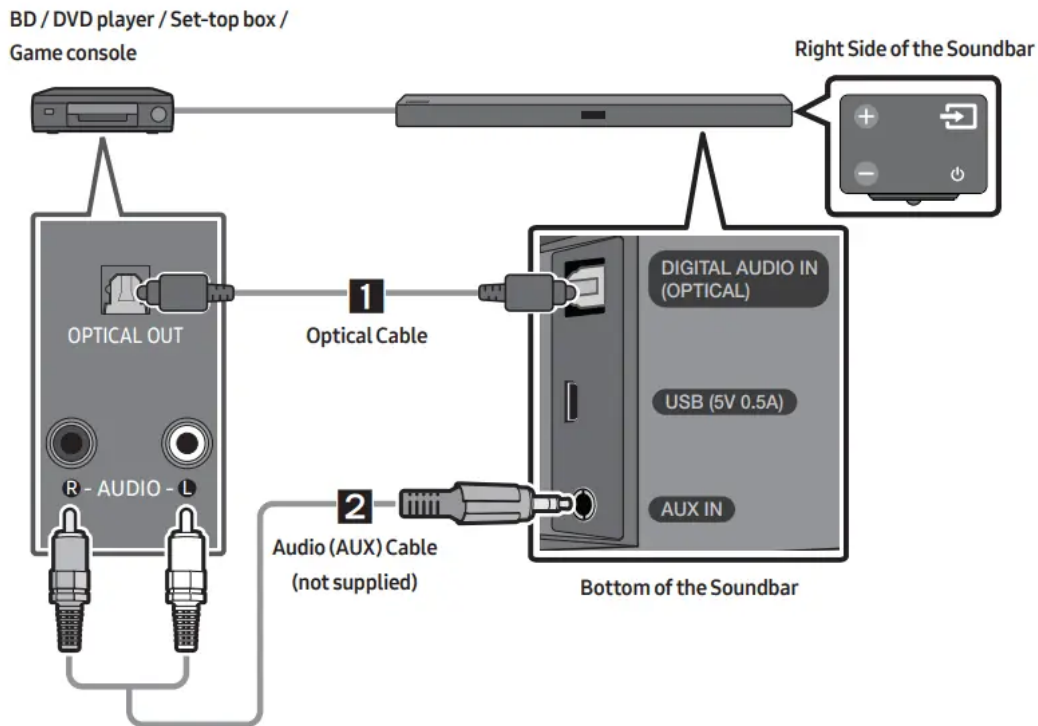

1. Optical Cable

1. Connect DIGITAL AUDIO IN (OPTICAL) on the main unit to the OPTICAL OUT jack of the Source Device using a digital optical cable.
2. Select "D.IN" mode by pressing the (Source) button on the right side panel or on the remote control.

2. Audio (AUX) Cable

1. Connect AUX IN (Audio) on the main unit to the AUDIO OUT jack of the Source Device using an audio cable.
2. Select "AUX" mode by pressing (Source) button on the right side panel or on the remote control.

CONNECTING A USB

You can play music files located on USB storage devices through the Soundbar.

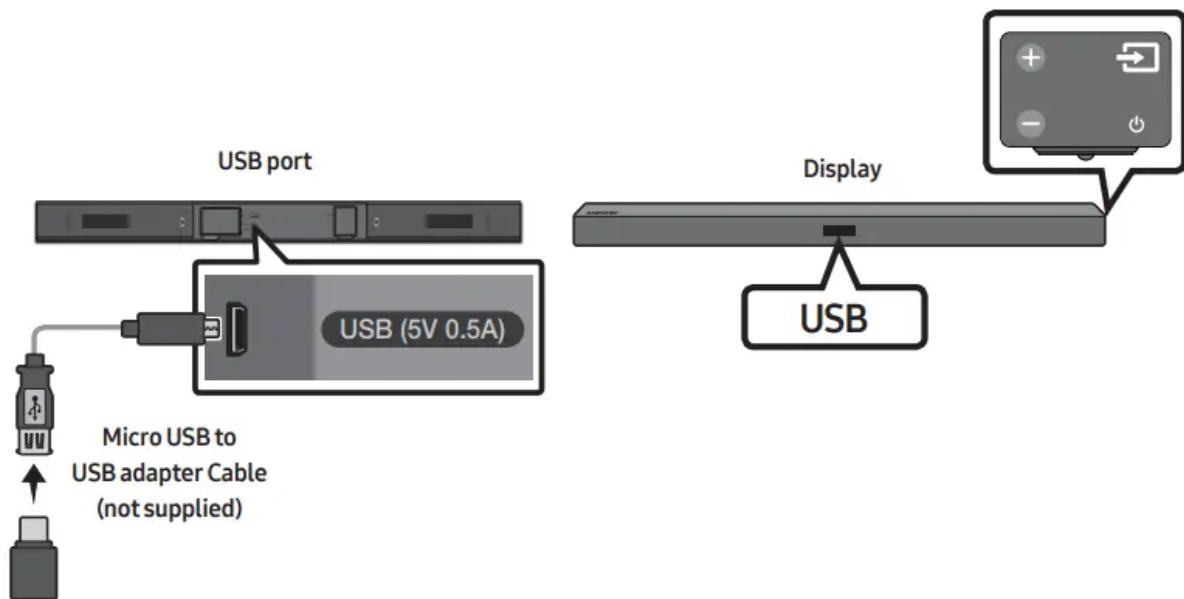

1. Connect a Micro USB to USB adapter cable with a male USB 2.0 Micro USB plug (Type B) on one end and a standard female 2.0 USB jack (Type A) on the other end to the micro USB jack on your Soundbar.
 - Micro USB to USB adapter Cable is sold separately. To purchase, contact a Samsung Service Center or Samsung Customer Care.
2. Connect your USB device to the female end of the adapter cable.
3. Press the (Source) button on the right side panel or on the remote control, and then select "USB".
4. "USB" appears in the display screen.
5. Play music files from the USB storage device through the Soundbar.
 - The Soundbar automatically turns off (Auto Power Off) if no USB device has been connected for more than 5 minutes.

File Format Type Compatibility list

Extension	Codec	Sampling Rate	Bitrate
*.mp3	MPEG 1 Layer2	16KHz ~ 48KHz	80kbps~320kbps
	MPEG 1 Layer3	16KHz ~ 48KHz	80kbps~320kbps
	MPEG 2 Layer3	16KHz ~ 48KHz	80kbps~320kbps
	MPEG 2.5 Layer3	16KHz ~ 48KHz	80kbps~320kbps
*.wma	Wave_Format_MSAudio1	16KHz ~ 48KHz	56kbps~128kbps
	Wave_Format_MSAudio2	16KHz ~ 48KHz	56kbps~128kbps
*.aac	AAC	16KHz ~ 96KHz	48kbps~320kbps
	AAC-LC	16KHz ~ 96KHz	128kbps~192kbps 5.1ch 320kbps
	HE-AAC	24KHz ~ 96KHz	48kbps~64kbps 5.1ch 160kbps
*.wav	-	16KHz ~ 48KHz	up to 3000kbps
*.ogg	OGG 1.1.0	16KHz ~ 48KHz	50kbps~500kbps
*.flac	FLAC 1.1.0, FLAC 1.2.1	16KHz ~ 96KHz	up to 3000kbps

- If there are too many folders and files stored on the USB device, it may take the Soundbar some time to access and play files.

CONNECTING A MOBILE DEVICE

Connecting via Bluetooth:

When a mobile device is connected using Bluetooth, you can hear stereo sound without the hassle of cabling.

- You cannot connect more than one Bluetooth device at a time



The initial connection

1. Press the (Source) button on the right side panel or on the remote control, and then select "BT".

2. Change “BT” to “BT PAIRING”.

- If “BT READY” appears, press and hold the (Source) button on the right side panel of the Soundbar or on the remote control for more than 5 seconds to display “BT PAIRING”.

3. Select “[AV] Samsung Soundbar Mxxx M-Series” from the list.

- When a Soundbar is connected to the Bluetooth device, [Bluetooth Device Name] → “BT” appears in the front display.

4. Play music files from the device, connected via Bluetooth, through the Soundbar

If the device fails to connect

- If the previously connected Soundbar listing (e.g. “[AV] Samsung Soundbar Mxxx M-Series”) appears in the list, delete it.
- In “BT” mode, press and hold the (Source) button for more than 5 seconds on the right side panel of the Soundbar or on the remote control to switch to “BT PAIRING” mode. Then, select “[AV] Samsung Soundbar Mxxx M-Series” from the Bluetooth device search list.

What are the BT READY and BT PAIRING statuses?

- BT READY : In this mode, you can search for previously connected TVs or connect to the Soundbar from a previously connected mobile device.
- BT PAIRING : In this mode, you can connect to a new device. (While in “BT” mode, press and hold the (Source) button for more than 5 seconds on the right side of the Soundbar or on the remote control.)

Bluetooth POWER On (Bluetooth POWER)

If a previously paired Bluetooth device tries to pair with the Soundbar when the Bluetooth POWER On function is on and the Soundbar is turned off, the Soundbar turns on automatically.

1. Press the Bluetooth POWER button on the remote while the Soundbar is turned on.
2. “ON-BLUETOOTH POWER” appears on the Soundbar’s display.

Disconnecting the Bluetooth device from a Soundbar

You can disconnect a Bluetooth device from the Soundbar. For instructions, see the Bluetooth device’s user manual.

- The Soundbar will be disconnected.
- When the Soundbar is disconnected from the Bluetooth device, the Soundbar will display “BT DISCONNECTED” on the front display.

Disconnecting the Soundbar from the Bluetooth device

Press the (Source) button on the right side panel or on the remote control, and then change to any mode except “BT”.

- Disconnecting takes time because the Bluetooth device must receive a response from the Soundbar. (Disconnection time may differ, depending on the Bluetooth device)
- When the Soundbar is disconnected from the Bluetooth device, the Soundbar will display “BT DISCONNECTED” on the front display.

NOTES

- In Bluetooth connection mode, the Bluetooth connection will be lost if the distance between the Soundbar and the Bluetooth device exceeds 10 meters.
- The Soundbar automatically turns off after 5 minutes in the Ready state.

More About Bluetooth:

Bluetooth is a technology that enables Bluetooth-compliant devices to interconnect easily with each other using a short wireless connection.

- A Bluetooth device may cause noise or malfunction, depending on usage, if:
 - A part of your body is in contact with the receiving/transmitting system of the Bluetooth device or the Soundbar.
 - It is subject to electrical variation from obstructions caused by a wall, corner, or office partition.
 - It is exposed to electrical interference from same frequency-band devices including medical equipment, microwave ovens, and wireless LANs.
- Pair the Soundbar with the Bluetooth device while they are close together.
- The further the distance between the Soundbar and Bluetooth device, the worse the quality is. If the distance exceeds the Bluetooth operational range, the connection is lost.
- In poor reception areas, the Bluetooth connection may not work properly.
- The Bluetooth connection only works when it is close to the unit. The connection will be automatically cut off if the Bluetooth device is out of range. Even within range, the sound quality may be degraded by obstacles such as walls or doors.
- This wireless device may cause electric interference during its operation.

Using the Samsung Audio Remote App

Installing the Samsung Audio Remote App

- To control the Soundbar with your smart device and the Samsung Audio Remote app, download the Samsung Audio Remote app from the Google Play store.

Market search : Samsung Audio Remote



Launching the Samsung Audio Remote App

To launch and use the Samsung Audio Remote app, touch the Audio Remote icon on your smart device, and then follow the directions on the screen.









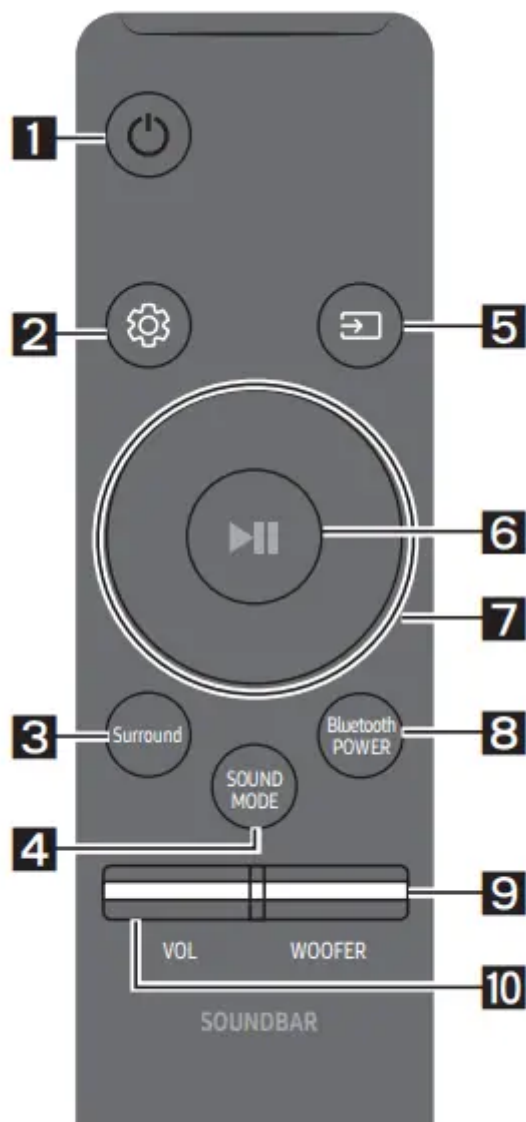



- The Samsung Audio Remote app is only compatible with Android mobile phones and mobile devices running Android OS 3.0 or later.

USING THE REMOTE CONTROL

How to Use the Remote Control



1	 Power	Turns the Soundbar on and off.
2	 Sound Control	<p>You can select from TREBLE, BASS, or AUDIO SYNC.</p> <ul style="list-style-type: none"> • To control the volume of the treble or bass sound, select TREBLE or BASS in Sound Settings, and then adjust the volume between -6~+6 by using the Up/Down buttons. • Press and hold the  (Sound Control) button for about 5 seconds to adjust the sound for each frequency band. 150Hz, 300Hz, 600Hz, 1.2KHz, 2.5KHz, 5KHz, and 10KHz are selectable (Left/Right) and each can be adjusted to a setting between -6 ~ +6 (Up/Down). • If the video and audio between the TV and your Soundbar are not synchronized, select AUDIO SYNC in Sound Settings, and then set audio delay between 0~300 milliseconds by using the Up/Down buttons. (Except “USB” mode) • Audio Sync is only supported in some functions.
3	 Surround	<p>The Surround Sound function adds depth and a sense of space to sound. Each time you press this button, ON and OFF alternate.</p> <ul style="list-style-type: none"> • ON : Play sound over all the speakers. • OFF : You can hear the sound of the original source channel from several speakers.
4	 SOUND MODE	<p>You can select the desired sound effect by choosing STANDARD, MUSIC, CLEAR VOICE, SPORTS, or MOVIE.</p> <p>Select the “STANDARD” mode if you want to enjoy the original sound.</p> <ul style="list-style-type: none"> • DRC (Dynamic Range Control) <p>Lets you apply dynamic range control to Dolby Digital tracks. If you press and hold the SOUND MODE button while in standby mode, DRC (Dynamic Range Control) turns on or off. With the</p>

		DRC turned on, loud sound is reduced. (The sound may be distorted.)
5	 Source	<p>6 Press to select a source connected to the Soundbar.</p> <ul style="list-style-type: none"> • BT PAIRING mode <p>To turn on “BT PAIRING” mode in “BT” mode, press and hold the  (Source) button for more than 5 seconds. See page 15 for details.</p> <ul style="list-style-type: none"> • Auto Power Down Function : The unit turns off automatically in the following situations. <ul style="list-style-type: none"> ◦ D.IN / BT / USB Mode : If there is no audio signal for 5 minutes. ◦ AUX Mode : <ul style="list-style-type: none"> ◦ If the Audio (AUX) Cable is disconnected for 5 minutes. ◦ If there is no KEY input for 8 hours when the Audio (AUX) Cable is connected. (Auto Power Down function can be turned off only in that case.) ◦ To turn off Auto Power Down function, while in “AUX” mode, press and hold the  button for 5 seconds. “ON-AUTO POWER DOWN” / “OFF-AUTO POWER DOWN” appears on the display.
6	 Play / Pause	<p>Press the  button to pause a music file temporarily. If you press the button again, the music file plays.</p>

7



Up/Down/
Left/Right



Press the indicated areas to select Up/Down/Left/Right.

Press Up/Down/Left/Right on the button to select or set functions.

- **Repeat:** To use the Repeat function in “**USB**” mode, press the **Up** button.
- **Music Skip:** Press the **Right** button to select the next music file. Press the **Left** button to select the previous music file.
- **Auto Power Link:** You can turn Auto Power Link on or off. Auto Power Link is controlled by the **Right** and **Left** buttons respectively.
 - Auto Power Link : If the Soundbar is connected to your TV through a digital optical cable, the Soundbar can automatically turn on when you turn on your TV. Press and hold the **Left** button for 5 seconds to toggle Auto Power Link ON and OFF.
 - Auto Power Link is set to ON by default.



8



**Bluetooth
POWER**

Press to turn the Bluetooth POWER or volume restriction function on and off.

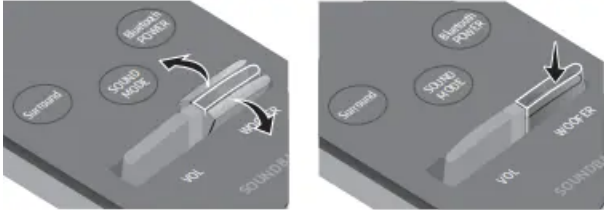
- **Bluetooth POWER function :** If the Soundbar is in standby mode and the Bluetooth POWER function is On, when you turn on a previously connected Bluetooth device, the Soundbar automatically turns on and connects via Bluetooth to the device.
 - When the Bluetooth POWER function is on, “**ON-BLUETOOTH POWER**” appears on the Soundbar display. To turn off the Bluetooth POWER function, press the **Bluetooth POWER** button once. Then “**OFF-BLUETOOTH POWER**” appears on the front display.

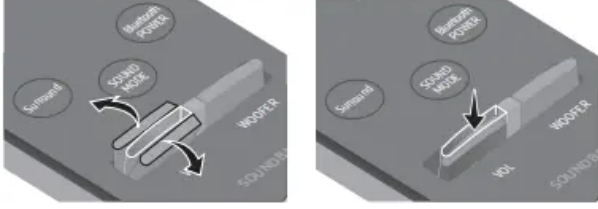

		<ul style="list-style-type: none"> ◦ If the “D.IN” mode is on and the Soundbar is connected to a Samsung smart TV released in 2017 or later, the Soundbar can be controlled with the TV remote control. In this mode, you cannot turn off Bluetooth POWER. • Volume restriction function : Because it may damage hearing when the power is turned on at high volumes, it adjusts the volume to 20 when the set volume is higher than 20. <ul style="list-style-type: none"> ◦ The default value for Volume restriction is off. The set volume is maintained even when the power is turned off. ◦ To change the setting, press the Bluetooth POWER button on the remote control for 5 seconds. With the volume restriction off, “V FREE” appears on the front display and with the function on, “V LOCK” appears.
9	 WOOFER	 <p>Push the button up or down to adjust the volume of the subwoofer to -12 or -6 to +6. Pressing the button reverts the subwoofer volume to level 0.</p>
10	 VOL	 <p>Push the button up or down to adjust the volume.</p> <ul style="list-style-type: none"> • Mute <p>Press the VOL button to mute the sound. Press it again to unmute the sound.</p>

Adjusting the Soundbar volume with a TV remote control



Use the TV menu to set the TV speaker on a Samsung TV to external speakers. (For more information, see the TV's user manual.)

- After installing the Soundbar, you can adjust the Soundbar's volume using the IR remote control that came with a Samsung TV. (If you do not want to use this function, when the Soundbar is on, press and hold the Surround button for 5 seconds. "OFF-TV REMOTE" appears in the Soundbar's display and the function turns off.) To adjust the volume using only the Samsung TV remote control, press and hold the Surround button for more than 5 seconds until "SAMSUNG-TV REMOTE" appears in the Soundbar display.
 - Each time the Surround button is held for 5 seconds, the mode switches in the following order: "SAMSUNG-TV REMOTE" (Default mode) → "OFF-TV REMOTE" → "ALL-TV REMOTE".
- To adjust the Soundbar volume with the remote control that came with a TV made by a third party manufacturer, turn the Soundbar on, press and hold the Surround button for 5 seconds ("OFF-TV REMOTE" appears on the Soundbar's display), release the Surround button, and then press and hold the Surround button again for more than 5 seconds. ("ALL-TV REMOTE" appears on the Soundbar's display.)
 - This function may not be available, depending on the remote control.
 - Manufacturers supporting this function: VIZIO, LG, Sony, Sharp, PHILIPS, PANASONIC, TOSHIBA, GRUNDIG, Hisense, RCA

Using the Hidden Buttons

Hidden Button		Reference page
Remote Control Button	Function	
Surround	TV remote control On/Off	page 22
 (Source)	BT Paring	page 15
▶ (Play / Pause)	Auto Power Down On/Off (AUX mode)	page 20
	Initialize (Standby)	page 28
VOL	ID SET (Standby)	page 7
Left	Auto Power Link ON/OFF	page 10
 (Sound Control)	7 Band EQ	page 19
SOUND MODE	DRC ON/OFF (Standby)	page 20
Bluetooth POWER	Volume restriction On/Off	page 21

Output specifications for the different sound effect modes

Effect		Input	Output	
			Except Wireless Rear Speaker Kit	Include Wireless Rear Speaker Kit
 Surround	ON	2.0 ch	2.1 ch	4.1 ch
		5.1 ch	2.1 ch	4.1 ch
 SOUND MODE	STANDARD	2.0 ch	2.1 ch	4.1 ch
		5.1 ch	2.1 ch	4.1 ch
	MUSIC	2.0 ch	2.1 ch	4.1 ch
		5.1 ch	2.1 ch	4.1 ch
	CLEAR VOICE	2.0 ch	2.1 ch	4.1 ch
		5.1 ch	2.1 ch	4.1 ch
	SPORTS	2.0 ch	2.1 ch	4.1 ch
		5.1 ch	2.1 ch	4.1 ch
	MOVIE	2.0 ch	2.1 ch	4.1 ch
		5.1 ch	2.1 ch	4.1 ch

- Samsung Wireless Rear Speaker Kit can be purchased separately. To purchase a Kit, contact the vendor you purchased the Soundbar from.

INSTALLING THE WALL MOUNT

Installation Precautions

- Install on a vertical wall only.
- Do not install in a place with high temperature or humidity.
- Verify whether the wall is strong enough to support the product's weight. If not, reinforce the wall or choose another installation point.
- Purchase and use the fixing screws or anchors appropriate for the kind of wall you have (plaster board, iron board, wood, etc.). If possible, fix the support screws into wall studs.
- Purchase wall mounting screws according to the type and thickness of the wall you want to mount the Soundbar on.
 - Diameter: M5
 - Length: 35 mm or longer recommended.
- Connect cables from the unit to external devices before you install the Soundbar on the wall.

- Make sure the unit is turned off and unplugged before you install it. Otherwise, it may cause an electric shock.

Wallmount Components

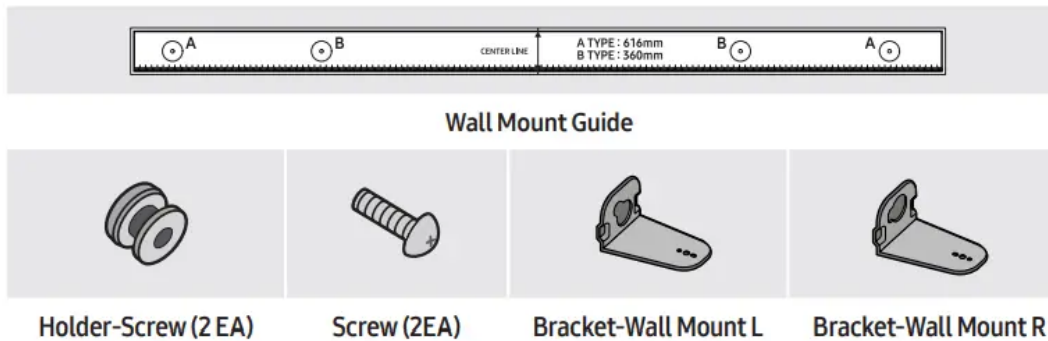

1. Place the Wall Mount Guide against the wall surface.

- The Wall Mount Guide must be level.
- If your TV is mounted on the wall, install the Soundbar at least 5 cm below the TV.

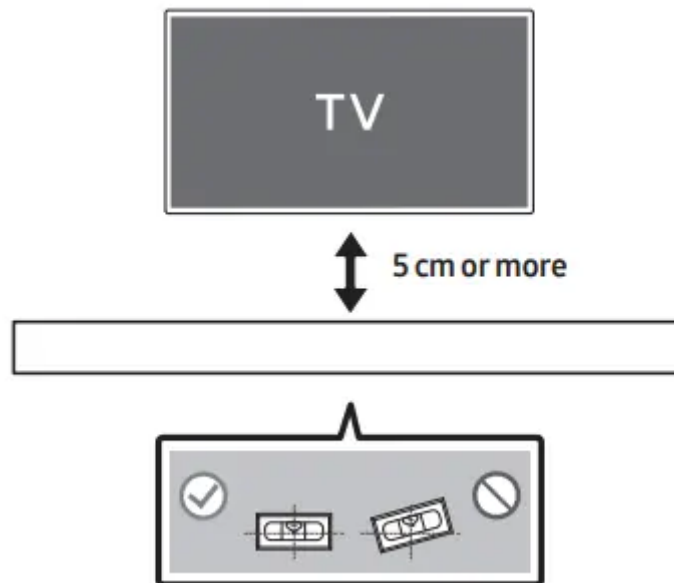

2. Align the Paper Template's Center Line with the center of your TV (if you are mounting the Soundbar below your TV), and then fix the Wall Mount Guide to the wall using tape.

- If you are not mounting below a TV, place the Center Line in the center of the installation area.

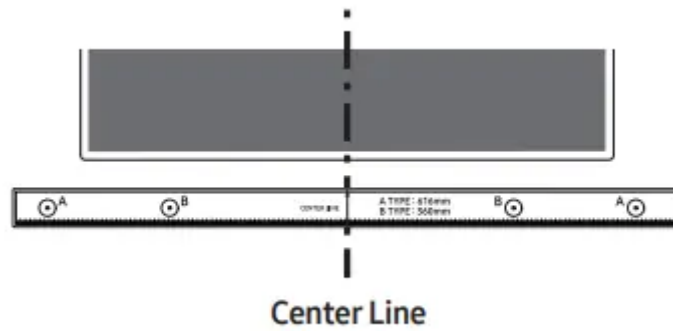

3. Push a pen tip or sharpened pencil tip through the center of the B-TYPE images on each end of the Guide to mark the holes for the supporting screws, and then remove the Wall Mount Guide.

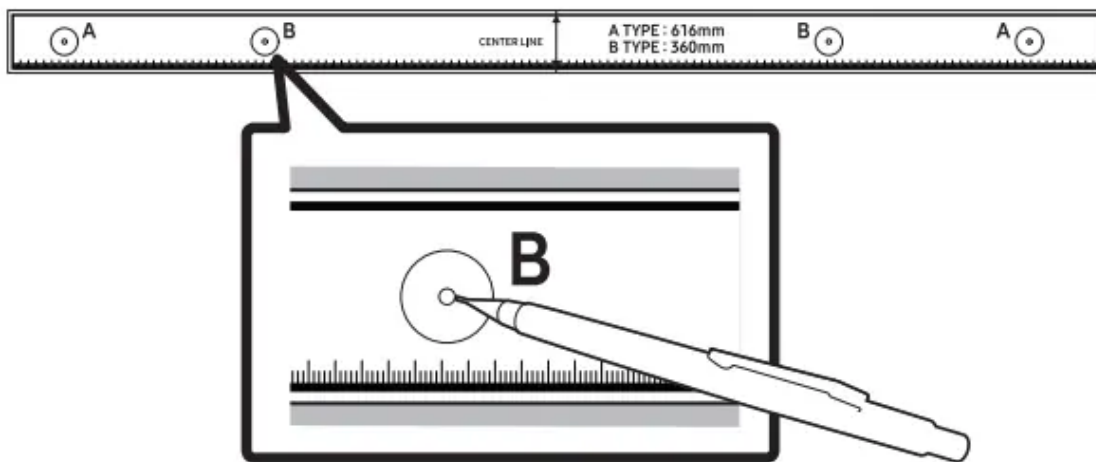

4. Using an appropriately sized drill bit, drill a hole in the wall at each marking.

- If the markings do not correspond to the positions of studs, make sure you insert appropriate anchors or mollys into the holes before you insert the support screws. If you use anchors or mollys, make sure the holes you drill are large enough for the anchors or mollys you use.

5. Push a screw (not supplied) through each Holder-Screw, and then screw each screw firmly into a support screw hole.

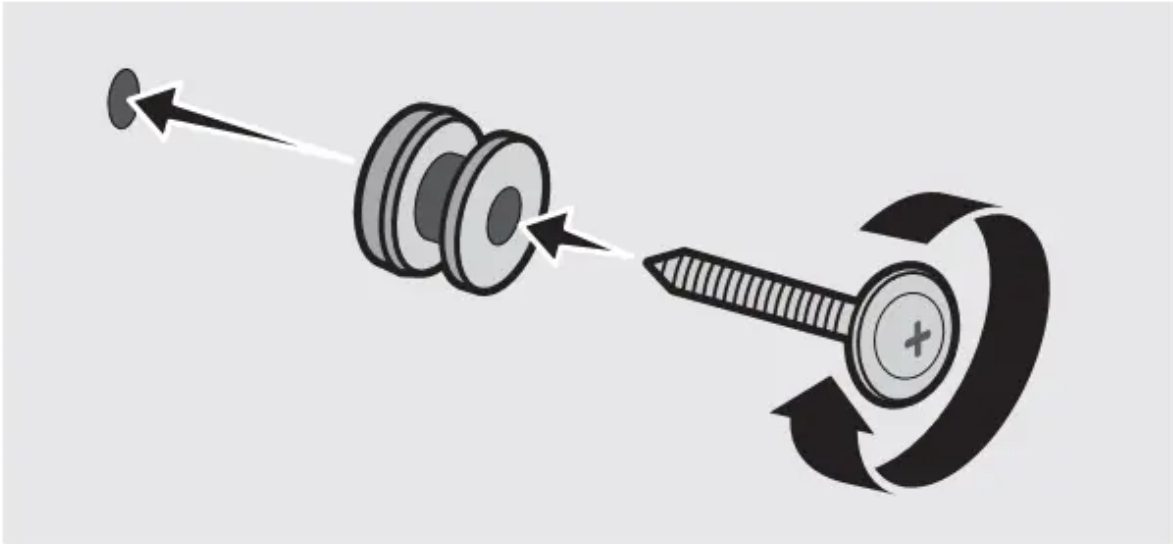

6. Use the two Screws (M4 x L12) to attach both Bracket-Wall Mount L and R to the Soundbar's bottom. For a proper fit, make sure to align the bumps on the Soundbar to the holes on the brackets.

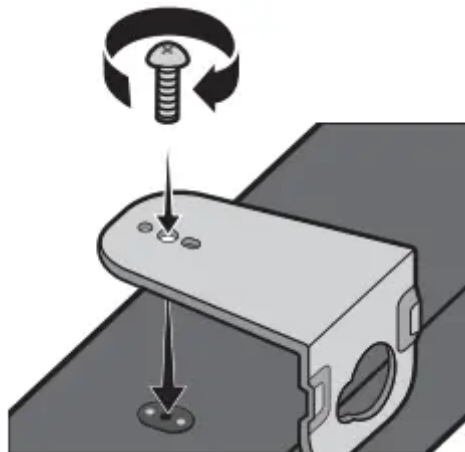

- When assembling, make sure the hanger part of the Bracket-Wall Mounts are located behind the rear of the Soundbar.

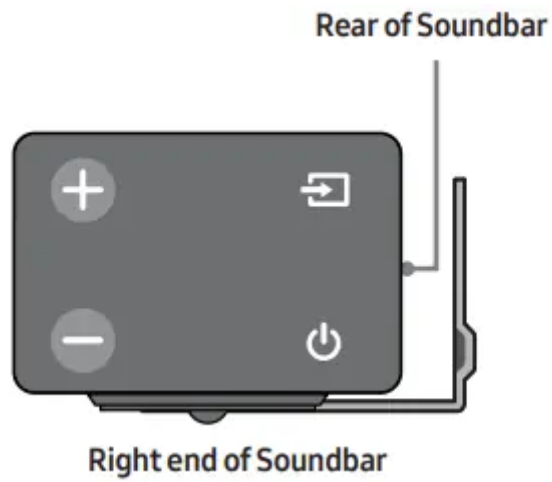

- The left and right mounts are different shapes. Make sure to position them correctly

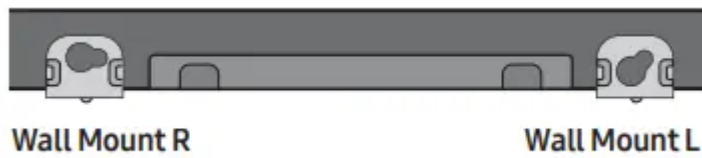

7. Install the Soundbar with the attached Bracket-Wall Mounts by hanging the Bracket-Wall Mounts on the Holder-Screws on the wall.

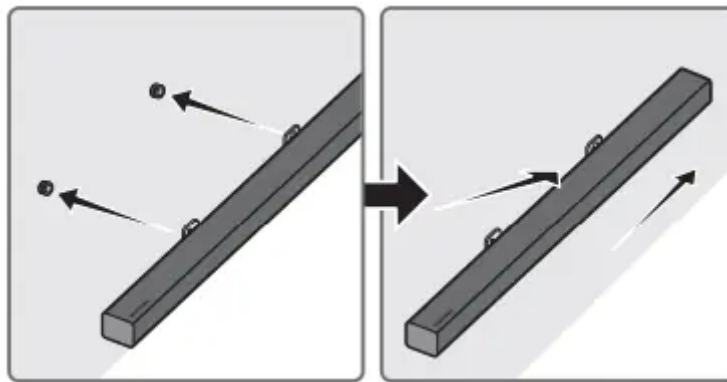

- Slightly tilt the Soundbar to insert both Holder-Screw heads into Bracket-Wall Mount holes. Push the Soundbar in the direction of the arrow to make sure both sides are firmly fixed.

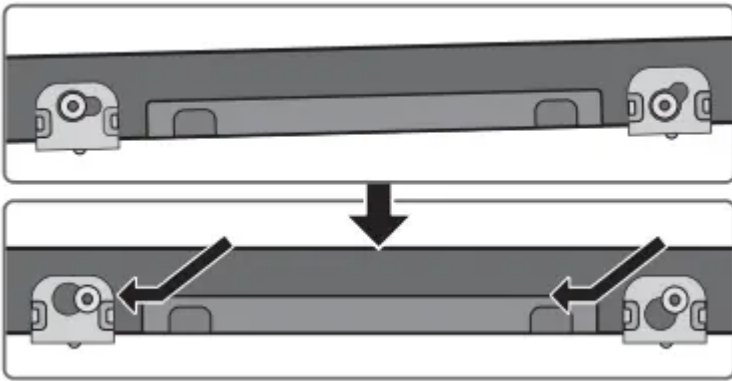

Detaching the Soundbar from the Wall

1. To separate the Soundbar from the wall mount, push it in the direction of arrow, tilt it up slightly, and then pull it away from the wall as shown

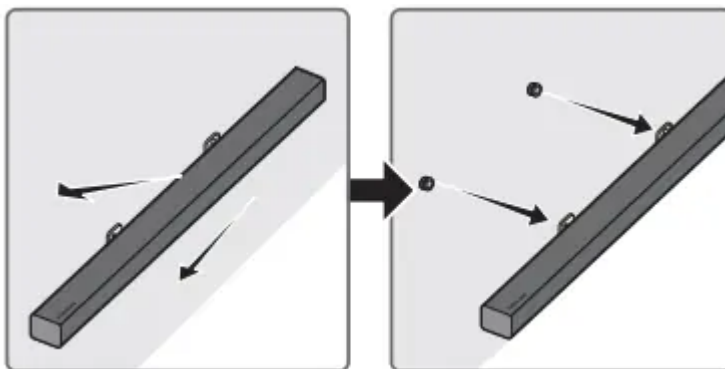

- Do not hang onto the installed unit and avoid striking or dropping the unit.
- Secure the unit firmly to the wall so that it does not fall off. If the unit falls off, it may cause an injury or damage the product
- When the unit is installed on a wall, please make sure that children do not pull any of the connecting cables, as this may cause it to fall.
- For the optimal performance of a wall mount installation, install the speaker system at least 5 cm below the TV, if the TV is mounted on the wall.
- For your safety, if you do not mount the unit on the wall, install it on a secure, flat surface where it is unlikely to fall.

SOFTWARE UPDATE

- Samsung may offer updates for the Soundbar's system firmware in the future.

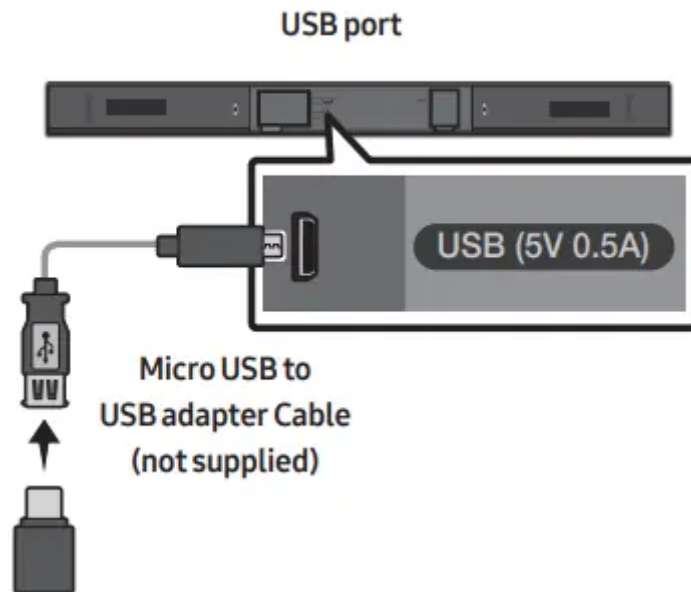

- If an update is offered, you can update the firmware by connecting a USB device with the firmware update stored on it to the USB port on your Soundbar.
- For more information about how to download update files, go to the Samsung Electronics website at (www.samsung.com → Support). Then, enter or select the model of your Soundbar, select Software & Apps, and then Downloads. The option name can vary.

Update Procedure

1. Connect a Micro USB to USB adapter cable with a male USB 2.0 Micro USB plug (Type B) on one end and a standard female 2.0 USB jack (Type A) on the other end to the micro USB jack on your Soundbar.
 - The Micro USB to USB adapter cable is sold separately. To purchase, contact a Samsung Service Center or Samsung Customer Care.
2. Follow the steps below to download the product software: Go to the Samsung website at (samsung.com) → search for the model name - select the customer support option (the option name is subject to change)
3. Save the downloaded software to a USB stick and select “Extract Here” to unzip the folder.
4. Turn off the Soundbar and connect the USB stick containing the software update to the female port on a Micro USB adapter cable. Connect the cable to the USB port on the Soundbar.
5. Turn on the Soundbar. Within 3 minutes, “UPDATE” is displayed and updating begins.

6. When the update finishes, the Soundbar turns off. Press the  button on the remote control for 5 seconds. "INIT" appears on the display and then the Soundbar turns off. The update is complete.
 - This product has a DUAL BOOT function. If the firmware fails to update, you can update the firmware again.

If UPDATE is not displayed

1. Turn off the Soundbar, disconnect and then reconnect the USB storage device that contains the update files to the Soundbar's USB port.
2. Disconnect the Soundbar's power cord, reconnect it, and then turn on the Soundbar.
 - Updating firmware may not work properly if audio files supported by the Soundbar are stored in the USB storage device.
 - Do not disconnect the power or remove the USB device while updates are being applied. The main unit will turn off automatically after completing the firmware update.
 - After update is completed, the user setup in Soundbar is initialized. We recommend you write down your settings so that you can easily reset them after the update. Note that updating firmware resets the subwoofer connection too. If the connection to the subwoofer is not re-established automatically after the update, refer to page 6. If the software update fails, check if the USB stick is defective.
 - Mac OS users should use MS-DOS (FAT) as the USB format.
 - Updating via USB may not be available, depending on the USB storage device manufacturer.

TROUBLESHOOTING

Before seeking assistance, check the following.

1. The unit will not turn on.
 - Is the power cord plugged into the outlet?
 - Connect the power plug to the outlet.
2. A function does not work when the button is pressed.
 - Is there static electricity in the air?
 - Disconnect the power plug and connect it again.
3. Sound dropouts occur in BT mode.
 - See the Bluetooth connection sections on pages 10 and 15

4. Sound is not produced.

- Is the Mute function on?
 - Press the VOL button to cancel the function.
- Is the volume set to minimum?
- Adjust the Volume.

5. The remote control does not work.

- Are the batteries drained?
 - Replace with new batteries.
- Is the distance between the remote control and Soundbar main unit too far?
 - Move the remote control closer to the Soundbar main unit.

6. The red LED on the subwoofer blinks and the subwoofer is not producing sound.

- This issue can occur if the subwoofer is not connected to the Soundbar main unit.
 - Try to connect your subwoofer again.

7. The subwoofer drones and vibrates noticeably.

- Try to adjust the vibration of your subwoofer.
 - Rock the WOOFER button on your remote control forward or backward to adjust the subwoofer level. (to -12, or between -6 ~ +6).

Warning

This content is compiled from multiple sources and is provided for reference purposes only. It may not be complete or fully applicable to all situations. If you are unable to resolve your issue, please contact the product manufacturer or an authorized service provider for official support.