

User Manual TV

TV components

Your TV has built-in controls for adjusting basic settings and several sets of jacks for connecting devices to your TV.

This section contains information about:

- Package contents
- Front features
- Side jacks
- Back jacks
- Remote control

Package contents

- 32" or 40" LED Sharp Roku TV
- Remote control and batteries (2 AAA)
- TV stands (2)
- Screws (4)
- Power cord (32" TV)
- *Quick Setup Guide*
- *Important Information*
- *Roku TV End User License Agreement (EULA)*

Front features

Besides the viewing screen, the front has a remote control sensor, to receive the signals from the remote control (do not block), and a status indicator.

The status indicator lights red when your TV is off, turns off when your TV is on, or blinks when receiving commands from the remote control.

Side jacks

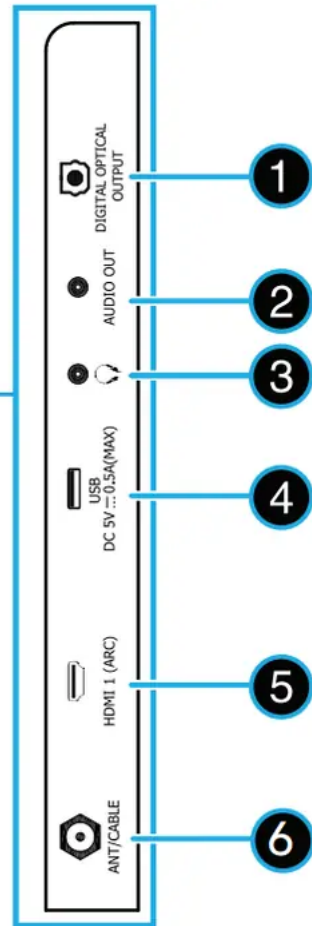
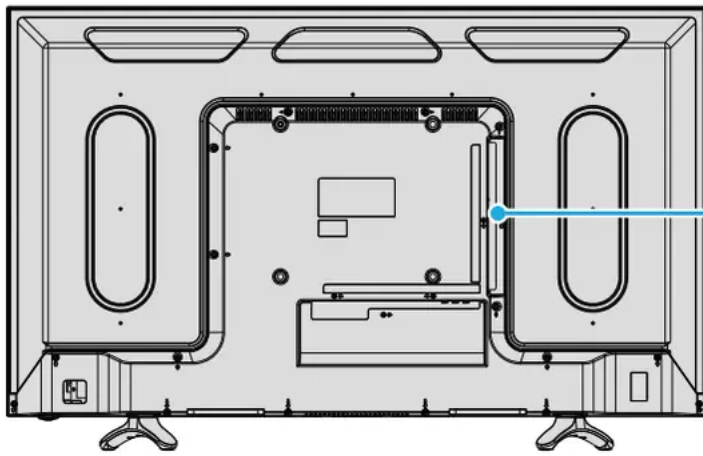

Item	Description
1. DIGITAL OPTICAL OUTPUT	Connect a digital sound bar, speaker system, or home theater system to this jack to listen to TV audio through external speakers. For more information, see Digital audio using the DIGITAL OPTICAL OUTPUT jack on page 28.
2. AUDIO OUT	Connect an analog sound bar, speaker system, or home theater system to this jack to listen to TV audio through external speakers. For more information, see Analog audio using the AUDIO OUT jack on page 30.
3.  (headphones)	Connect headphones to this jack. See Connecting headphones on page 27.
4. USB	Connect a USB flash drive to this jack to view compatible photos and video, listen to music files, or pause live TV. For more information, see Connecting a USB flash drive on page 26 and Pause live TV on page 7.
5. HDMI 1 (ARC)	Connect HDMI® devices to this jack. For more information, see HDMI® (best) on pages 17, 21, or 23 or Connecting a computer on page 25. Connect an ARC-enabled home theater receiver to this jack. For more information, see Digital audio using the HDMI 1 (ARC) jack on page 29.
6. ANT/ CABLE	Connect an antenna or cable TV to this jack. For more information, see Coaxial (good) on page 19 or Connecting an antenna or cable TV (no box) on page 20.







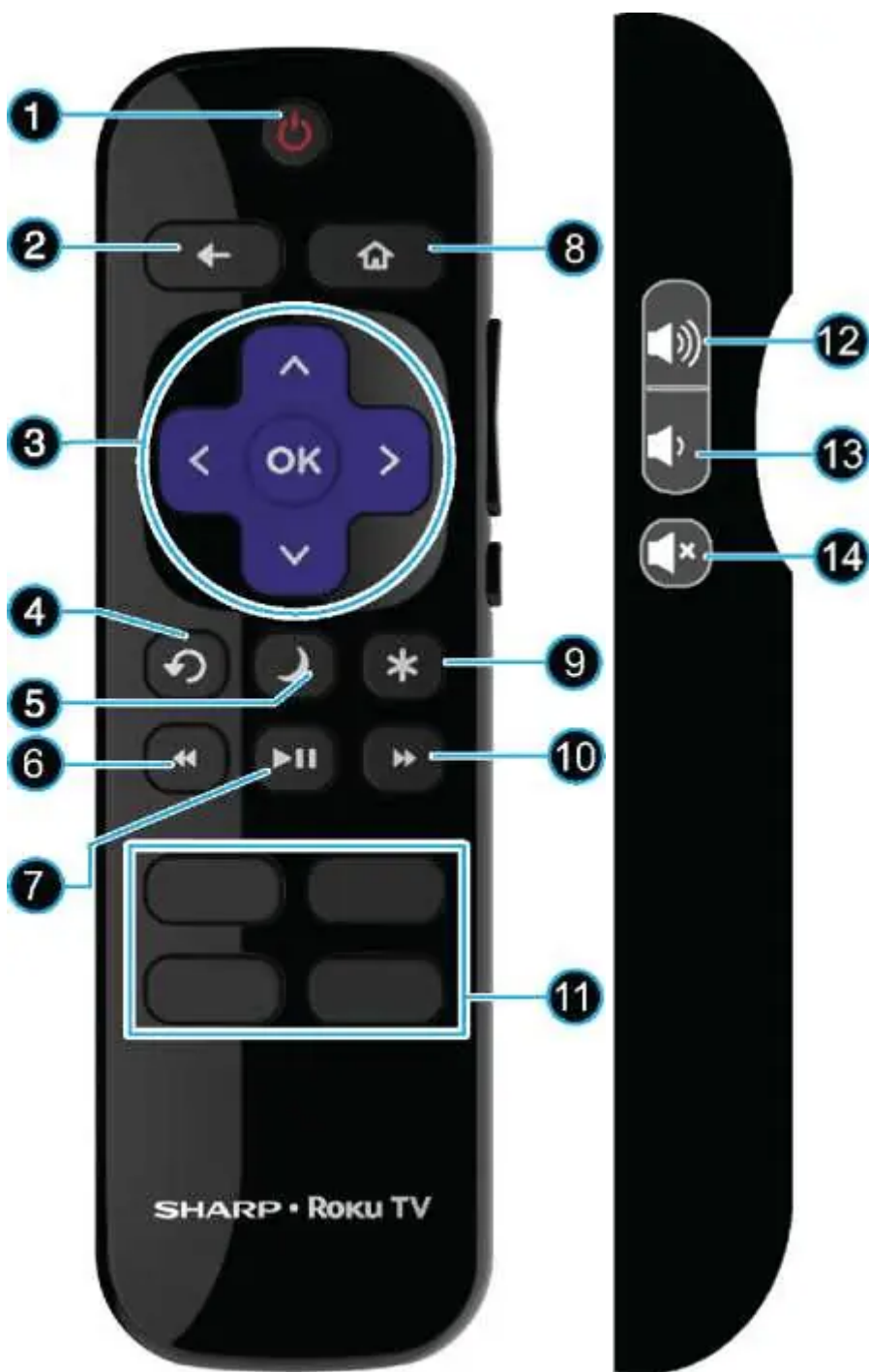

Back jacks

Item	Description
1. HDMI 2/HDMI 3	Connect HDMI® devices to these jacks. For more information, see HDMI® (best) on pages 17, 21, or 23 or Connecting a computer on page 25.
2. RESET	Press and hold reset for 15 seconds for factory reset.
3. VIDEO/ L and R AUDIO	Connect an AV device to these jacks. For more information, see AV (good) on page 18, 22, or 24.

Remote control





#	Button	Description
1	 (power)	Turns your TV on or off.
2	 (back)	<p>The action depends on what you are doing with your TV:</p> <p>Menu—Goes back to the previous menu or screen.</p> <p>Home screen tile—Moves the highlight back to the Home menu option.</p> <p>Watching Antenna TV or a TV input—Returns to the screen from which the input was selected.</p> <p>Playing streaming content—Stops playing stream and returns to the previous menu or screen.</p> <p>Browsing streaming content—Goes to the previous level in the content tree.</p>
3	 and OK	<p> / —Moves the highlight up or down one item.</p> <p>—Moves the highlight left, if a < hint appears.</p> <ul style="list-style-type: none"> • When watching TV, displays your channel list. • When playing most streaming videos, skips backward in the video. <p>—Moves the highlight to the right, if a > hint appears.</p> <ul style="list-style-type: none"> • When watching TV with the channel list displayed, dismisses the channel list. • When playing most streaming videos, skips forward in the video. <p>OK—Selects the highlighted option.</p> <ul style="list-style-type: none"> • When watching TV, displays information for the current TV program.
4	 (previous)	<p>Watching Antenna TV or cable (no set-top box)—Changes to the previous channel.</p> <p>Playing streaming content—Jumps back one position in the video.</p> <p>Menu—Backspaces one letter during menu entries, such as Search.</p>

5	☾ (sleep)	<p>First press displays a banner showing the remaining sleep time, if any, or Sleep timer is off. Subsequent presses cycle among the preset sleep time intervals: 30 minutes, 1 hour, 1.5 hours, 2 hours, and 3 hours. After it is set, the Sleep timer remains in effect regardless of what you are watching.</p>
6	◀◀ (rewind)	<p>When playing streaming video that supports this feature or broadcast TV if Live TV Pause is enabled, cycles through 1×, 2×, and 3× rewind speeds.</p> <p>When playing streaming audio, jumps to the previous track/selection.</p> <p>When any menu, tile, or channel in the channel list is highlighted, jumps up one page.</p> <p>When using a virtual keyboard, jumps to the character at the top of the current column.</p>
7	▶▶ (play/pause)	<p>Pauses and plays streaming content.</p>
8	🏠 (home)	<p>Immediately returns to the Home screen and stops playback if you are watching TV or streaming content.</p>
9	* (options)	<p>Displays an <i>Options</i> menu, but only when the Options * hint in the upper right corner of the screen is not dimmed. The menu you see varies depending on what you are doing with your TV.</p> <p>Also, in most cases, pressing * while video is playing displays an <i>Options</i> menu over part of the screen where you can adjust various picture and sound settings.</p>
10	▶▶ (fast forward)	<p>When playing streaming video that supports this feature or broadcast TV if Live TV Pause is enabled, cycles through 1×, 2×, and 3× fast-forward speeds.</p> <p>When playing streaming audio, jumps to the next track/selection.</p> <p>When any menu, tile, or channel in the channel list is highlighted, jumps down one page.</p> <p>When using a virtual keyboard, jumps to the character at the bottom of the current column.</p>

11 Streaming Channels Shortcuts

Dedicated buttons show the logo of a featured streaming content provider. Pressing a button turns your TV on (if your TV is not already on), and if your TV is operating and is connected to the internet, performs one of the following actions:

- Displays the streaming channel's main page if you have already added the channel to your **Home** screen.
- Displays the streaming channel's sign-up page if you have not already added the channel so that you can agree to any terms and fees for the service.

12  (volume up)

Turns the volume up one setting with each press. Press and hold to turn the volume up rapidly. A volume indicator shows the volume level while you are adjusting the volume and for a few seconds afterward.
Note: If your TV is muted, pressing  unmutes the sound.

13  (volume down)

Turns the volume down one setting with each press. Press and hold to turn the volume down rapidly. A volume indicator shows the volume level while you are adjusting the volume and for a few seconds afterward.
Note: If your TV is muted, pressing  does not unmute the sound.

14  (mute)

Mutes and unmutes the TV sound. A volume indicator shows the current volume level and a mute icon when you press  and for a few seconds afterward. If **Closed captioning** is set to **When Mute**, captions are displayed while your TV is muted.

Connecting a cable or satellite box

HDMI® (best)

Note: For better picture quality, we recommend that you use cables designated as High Speed HDMI® cables.

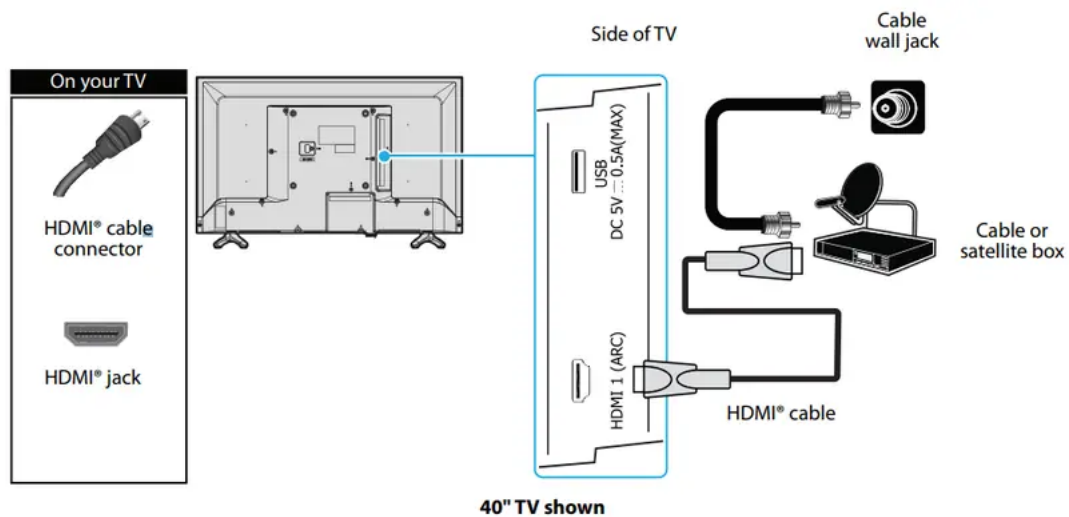

1. Make sure that your TV's power cord is unplugged and all connected devices are turned off.
2. Connect the incoming cable from the cable wall jack to the cable-in jack on the cable or satellite box.
3. Connect an HDMI® cable (not provided) to an HDMI jack on your TV and to the HDMI OUT jack on the cable or satellite box.
4. Plug your TV's power cord into a power outlet, turn on your TV, then turn on the cable or satellite box.
5. On the Home screen, press \wedge \vee $<$ or $>$ to highlight the HDM11, HDMI 2, or HDMI 3 tile, then press OK.

Note: An HDMI® cable carries both audio and video. You do not need to use any audio cables.

AV (good)

Notes: Cables are often color-coded to match color-coded jacks.

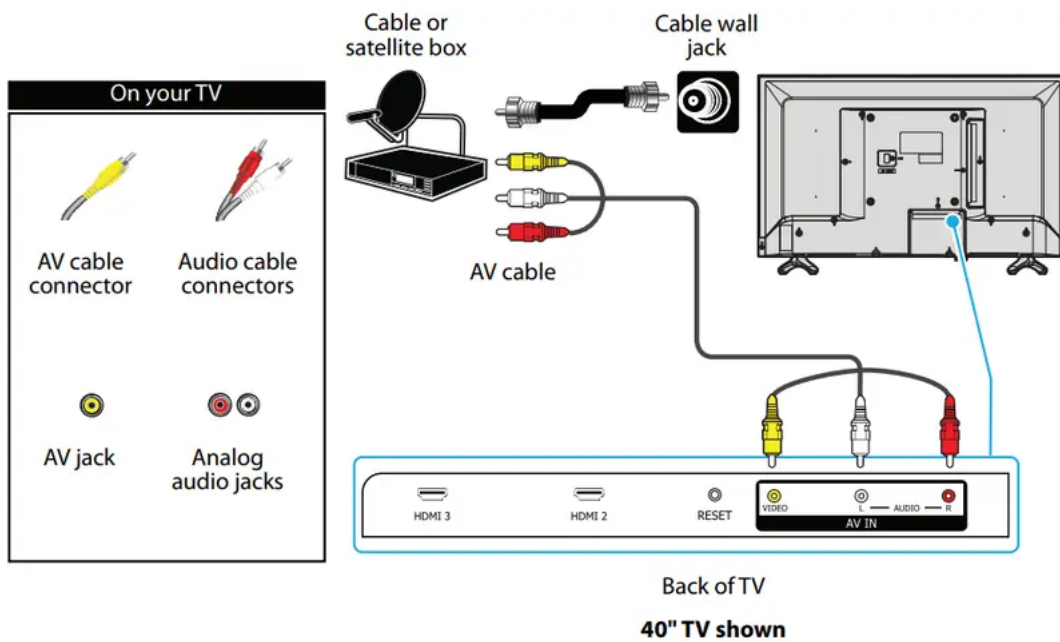

1. Make sure that your TV's power cord is unplugged and all connected devices are turned off.
2. Connect the incoming cable from the cable wall jack to the cable-in jack on the cable or satellite box.
3. Connect an AV cable (not provided) to the VIDEO jack and L and R AUDIO jacks on your TV and to the AV and audio out jacks on the cable or satellite box.

Note: When you connect the audio using the L and R AUDIO jacks, the audio output is analog.

4. Plug your TV's power cord into a power outlet, turn on your TV, then turn on the cable or satellite box.
5. On the Home screen, press \wedge \vee $<$ or $>$ to highlight the AV tile, then press OK.

Coaxial (good)

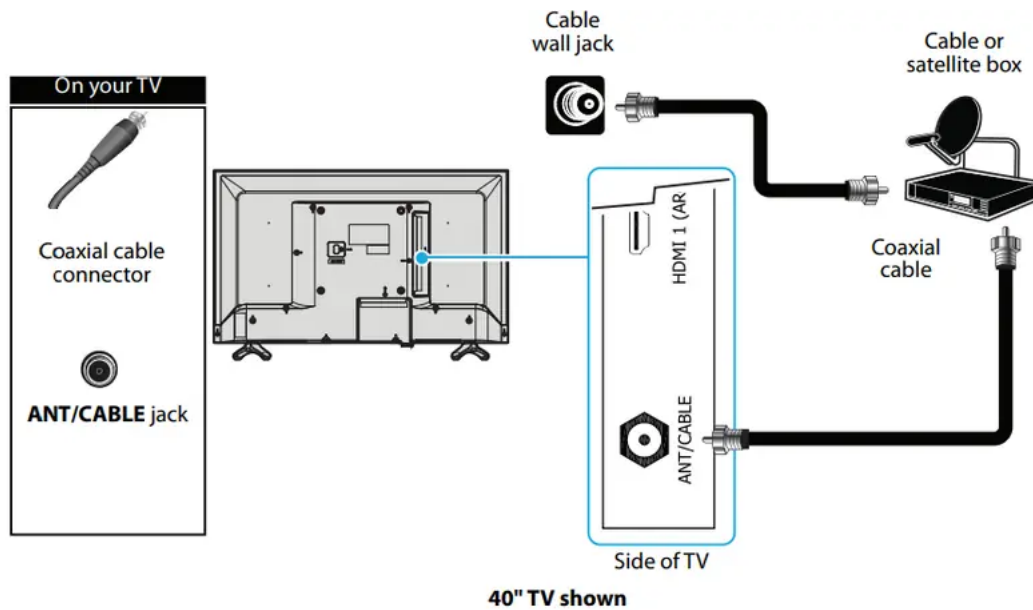

1. Make sure that your TV's power cord is unplugged and all connected devices are turned off.
2. Connect the incoming cable from the cable wall jack to the cable-in jack on the cable or satellite box.
3. Connect a coaxial cable (not provided) to the ANT/CABLE jack on your TV and to the coaxial out jack on the cable or satellite box.
4. Plug your TV's power cord into a power outlet, turn on your TV, then turn on the cable or satellite box.
5. On the Home screen, press **^ v < or >** to highlight the Antenna TV tile, then press **OK**. If you have not set up the TV tuner, follow the on-screen instructions.

Note:

- Use a coaxial cable to eliminate interference and noise from radio waves.
- Do not bundle the coaxial cable with the power cord or other cables.

Connecting an antenna or cable TV (no box)

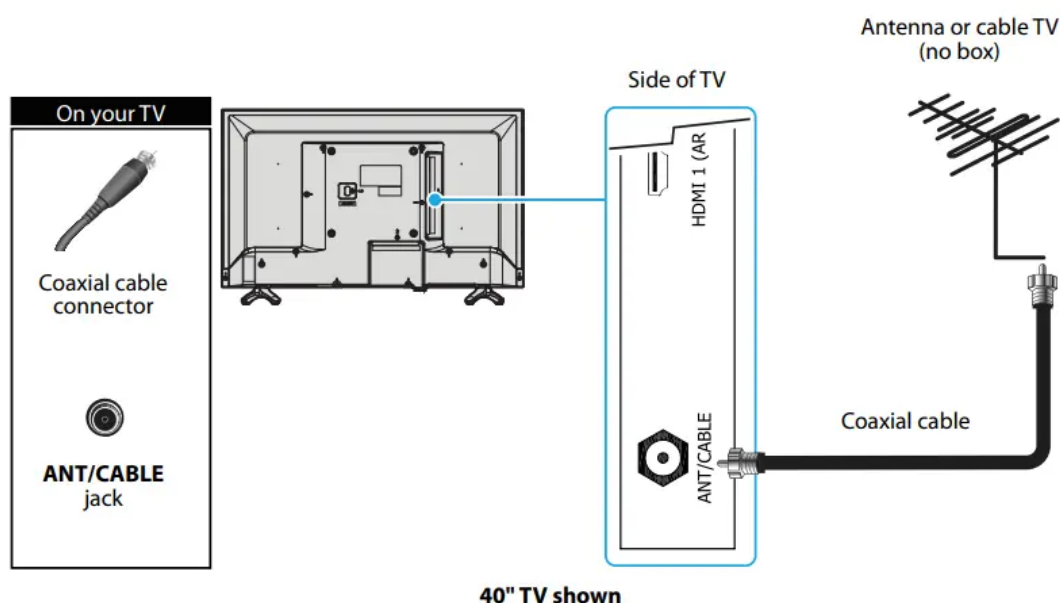

1. Make sure that your TV's power cord is unplugged and all connected devices are turned off.
2. Connect a coaxial cable (not provided) to the ANT/CABLE jack on your TV and to the antenna or cable TV wall jack.
3. Plug your TV's power cord into a power outlet, then turn on your TV.
4. On the Home screen, press \wedge \vee $<$ or $>$ to highlight the Antenna TV tile, then press OK. If you have not set up the TV tuner, follow the on-screen instructions.

Note:

- Use a coaxial cable to eliminate interference and noise from radio waves.
- Do not bundle the coaxial cable with the power cord or other cables.
- If the antenna is not installed correctly, contact qualified service personnel to correct the problem.
- If the signal level for a channel is weak, the picture may be distorted. Adjust the antenna or use a highly directional outdoor or set-top antenna with a built-in amplifier.
- If the picture quality is good on some channels and poor on others, the problem may be caused by a poor or weak signal from the broadcaster or cable TV provider.
- If you connect to cable TV without a set-top box and experience poor picture quality, you may need to install a set-top box to improve signal reception and picture quality. Contact your cable TV provider about upgrading to a set-top box.
- Many high-definition (HD) channels upscale standard-definition (SD) content. The picture displayed on your TV is still displayed as SD, thus the picture quality will not be as clear or crisp as it would be if the content was originally recorded in HD.

Connecting a DVD or Blu-ray player

HDMI® (best)

Note: For better picture quality, we recommend that you use cables designated as High Speed HDMI® cables.

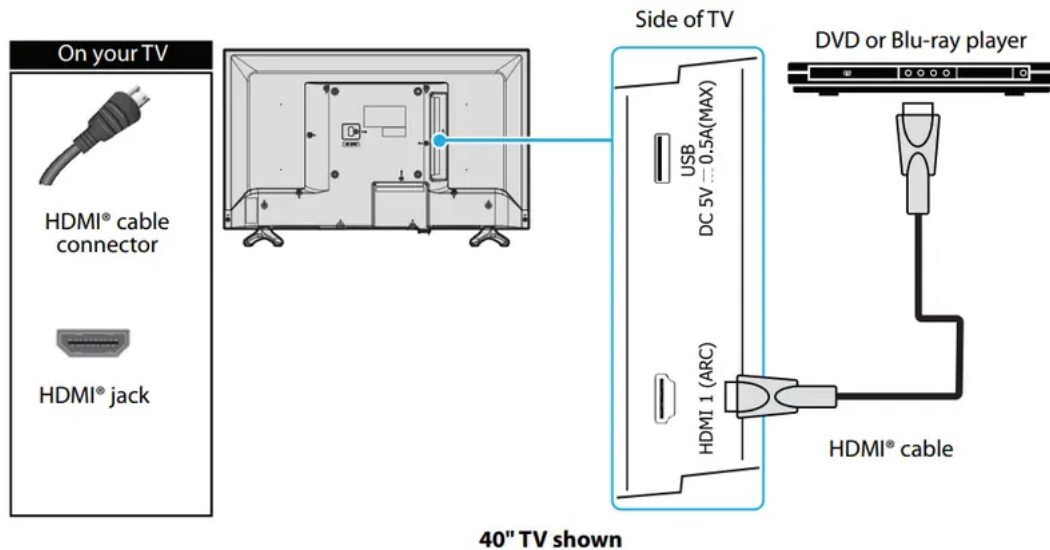

1. Make sure that your TV's power cord is unplugged and the DVD or Blu-ray player is turned off.
2. Connect an HDMI® cable (not provided) to an HDMI jack on your TV and to the HDMI OUT jack on the DVD or Blu-ray player.
3. Plug your TV's power cord into a power outlet, then turn on your TV and DVD or Blu-ray player.
4. On the Home screen, press \wedge \vee $<$ or $>$ to highlight the HDM11, HDMI 2, or HDMI 3 tile, then press OK.

Note: An HDMI® cable carries both audio and video. You do not need to use any audio cables.

AV (good)

Note: Cables are often color-coded to match color-coded jacks.

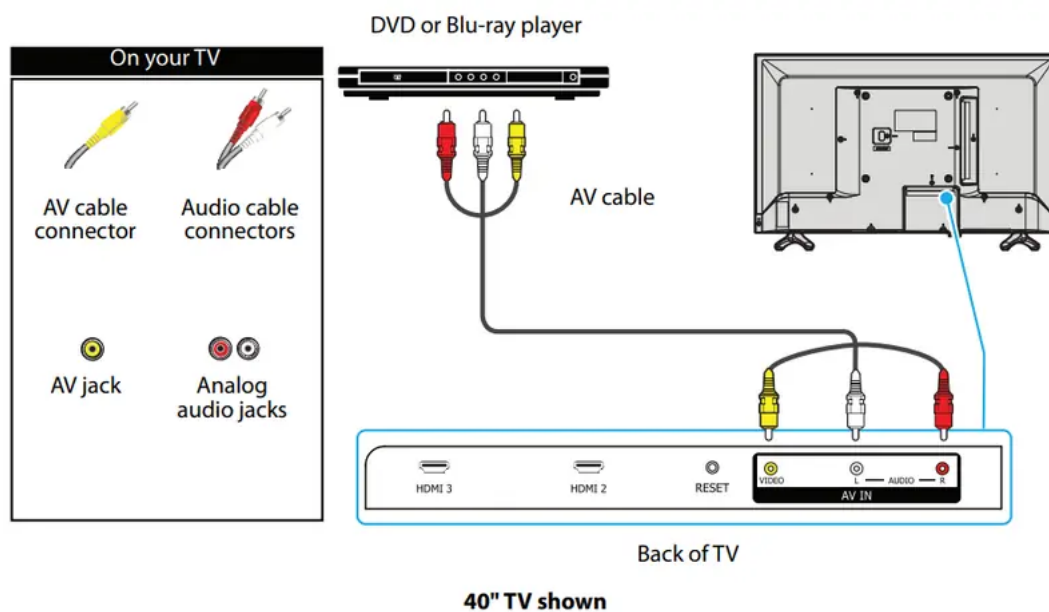

1. Make sure that your TV's power cord is unplugged and the DVD or Blu-ray player is turned off.
2. Connect an AV cable (not provided) to the VIDEO jack and L and R AUDIO jacks on your TV and to the AV OUT jacks on the DVD or Blu-ray player.

Note: When you connect the audio using the L and R AUDIO jacks, the audio output is analog.

3. Plug your TV's power cord into a power outlet, then turn on your TV and DVD or Blu-ray player.
4. On the Home screen, press \wedge \vee $<$ or $>$ to highlight the AV tile, then press OK.

Setting up your TV

When you turn on your TV for the first time, Guided Setup starts. During Guided Setup:

- Your TV automatically detects your wireless network, so have your network name and password handy and follow the easy on-screen instructions.
- You'll be prompted to create your Roku account online. Your TV generates a unique code that links your TV to your new account.

Note: Roku accounts are free, and while a valid credit card number is not required, providing your card information makes renting and purchasing entertainment a breeze.

- After you are connected to your account, your TV automatically updates with the latest software, and you can start streaming immediately.

Note: If you aren't ready to connect your TV to a wireless network, you can still use it as a regular TV.

Maintaining

- Do not use your TV in areas that are too hot or too cold, because the cabinet may warp or the screen may malfunction. Your TV works best in temperatures that are comfortable to you.
- Storage temperatures are 5° to 113°F (-15° to 45°C).
- Working temperatures are 41° to 95°F (5° to 35°C).
- Do not place your TV in direct sunlight or near a heat source.

Cleaning your TV cabinet

Clean the cabinet with a soft, lint-free cloth. If the cabinet is especially dirty, moisten a soft, lint-free cloth in a weak detergent solution, squeeze the excess moisture from the cloth, then wipe the cabinet with the cloth. Use a clean cloth to dry the cabinet.

Cleaning your TV screen

Clean the screen with a soft, lint-free cloth.

Troubleshooting

Warning: Do not try to repair your TV yourself. Contact authorized service personnel.

Note: If the problem is not solved by using these troubleshooting instructions, turn off your TV, then turn it on again.

Note: If you have any other questions about how to use your TV that are not covered in this User Guide, go to <http://support.roku> and select your TV brand and model.

Video and audio

Symptom	Possible cause
Picture does not fill the screen or there are black bars around the picture	The picture size may need to be adjusted
I don't see a picture when I select an input	TV is not on
	Cables are not connected correctly
	Picture settings may be incorrect
	Incorrect input may be selected
	Input source not detected
	TV input may be bad
TV channel does not appear	Broadcast TV may be experiencing problems or may not be set up



<p>Dark, poor, or no picture (screen is lit), but sound is good</p>	<p>Broadcast TV may be experiencing problems or may not be set up</p> <hr/> <p>Cables may not be connected correctly</p> <hr/> <p>Picture settings may be incorrect</p>
<p>No color, dark picture, or color is not correct</p>	<p>Picture settings may be incorrect</p> <hr/> <p>Broadcast TV may be experiencing problems</p> <hr/> <p>Cables are not connected correctly</p>



<p>Only snow (noise) appears on the screen</p>	<p>Broadcast TV may be experiencing problems or may not be set up</p> <p>Cables may not be connected correctly</p>
<p>Picture quality is good on some channels and poor on others. Sound is good</p>	<p>Broadcast signal may be weak</p>
<p>Dotted lines or stripes appear on the screen</p>	<p>Cables may not be connected correctly</p> <p>Broadcast signal may be weak</p>



Double images	Broadcast signal may be weak
The picture has a few bright or dark spots	This is normal in LED TVs
Good picture, but no sound	Volume is down or muted
	Headphones may be connected
	TV speakers may be turned off
	You may need to change the audio mode
	Home theater system, sound bar, or external speaker system may not be turned on or may not be set up correctly



	Bad content, no audio
	Cables may not be connected correctly
	Light in the viewing area may be interfering
Poor picture	A connected camera or camcorder may be interfering
Audio noise	Other devices may be interfering
After images appear	

Remote control

Symptom	Possible cause	Try this...
My TV doesn't turn on using the remote control	No power to TV	<ul style="list-style-type: none"> • Make sure that the power cord is correctly connected to both your TV power connector and power outlet. See Connecting power on page 32. You should see an LED in the front of the TV panel when a button on the remote is pressed. If you see no LED activity, try another outlet or check your fuse box.
	Line-of-sight obstructed	<ul style="list-style-type: none"> • Make sure that no objects (or pets) are obstructing the line-of-sight from the remote control to the remote sensor on the front of your TV. See Aiming the remote control on page 33.
	Remote not responding	<ul style="list-style-type: none"> • Open the battery compartment and make sure that the batteries are seated in the correct positions (+ and - in the correct positions). See Installing remote control batteries on page 33. • Make sure that the batteries are fresh and working correctly. Replace the batteries, if necessary.
	TV frozen	<ul style="list-style-type: none"> • If the front LED is not responding, or abnormally bright, disconnect the power cord from the power outlet, wait a few seconds, then reconnect the power cord.
Trouble programming your existing universal remote control	Remote control may not be programmed correctly	<ul style="list-style-type: none"> • For instructions on programming a universal remote control • Refer to the User Guide that accompanied your universal remote control and contact the manufacturer if problems persist.
	Batteries may be dead	<ul style="list-style-type: none"> • Replace dead batteries with new batteries. Refer to the User Guide that accompanied your universal remote control.

General

Symptom	Possible cause
No power	Power cord may not be connected correctly
	Other devices may be interfering
My TV tuner does not pick up as many over-the-air channels as it should	Antenna may not be placed optimally
	Broadcast TV may not be set up
One or more channels do not display	Channels may be blocked or hidden
	The wrong input may be selected



	You may need to use the remote control that came with the cable or satellite box
I lost my parental control PIN	Need PIN recovery
Some settings cannot be accessed	Not all settings are available for all devices or inputs
TV cabinet creaks	This is normal
Control buttons do not work	TV may be frozen
TV keeps turning off	Sleep timer may be turned on
Some features are not available	The wrong TV mode may be selected

Roku



Symptom	Possible cause	Try this...
How can I find out more about using my TV?		<ul style="list-style-type: none"> • If you need help with using your TV or Roku
I can't turn my TV on with the Roku mobile app	Your TV is "asleep"	<ul style="list-style-type: none"> • You will need to use the physical remote button to "wake up" or turn on your TV.
I can't find my TV with the Roku mobile app	TV and mobile app not on same wireless network	<ul style="list-style-type: none"> • Make sure that your TV and the mobile app are on the same network.
	TV not powered or working normally	<ul style="list-style-type: none"> • Make sure that your TV is connected to a working power outlet and that your TV is turned on. See Connecting power on page 32.

Network



Symptom	Possible cause	Try this...
I cannot connect to the internet	Network connection may not be set up	<ul style="list-style-type: none"> • If you did not connect to the internet when you first set up your TV, set up a network connection.
	Network name or password may have changed	<ul style="list-style-type: none"> • If your network name or password has changed, you need to update your network connection.
Streaming keeps pausing to load more data	Wireless LAN not optimized	<ul style="list-style-type: none"> • Rotate wireless router slightly • Elevate the router • Turn off other wireless connections • Use 5.0Ghz, if possible. Roku TVs support dual band.
	Insufficient broadband speed	<ul style="list-style-type: none"> • Turn off other wireless connections that may also be using bandwidth.

CEC-compatible devices



Symptom	Possible cause
My TV is not displaying the video from the connected CEC device	Cables may not be connected correctly
	Picture settings may be incorrect
	The selected input may be incorrect
	Connected device may not be a CEC device
	CEC control may not be set up correctly
My TV is not playing the audio from the connected CEC device.	Cables may not be connected correctly
	Volume may be too low or muted
	TV speakers may be turned off
	Connected device may not be a CEC device
	CEC control may not be set up correctly



	<p>Connected audio device may not be set up correctly</p>
<p>My TV's remote control does not control the device</p>	<p>Connected device may not be turned on</p> <p>Line-of-sight obstructed</p> <p>Connected device may not support some or all CEC features</p> <p>CEC control may not be set up correctly</p>
<p>The device does not show up in the CEC device list</p> <p>The device does not show up in the CEC device list</p>	<p>Connected device may not be a CEC device</p> <p>Cables may not be connected correctly</p> <p>CEC control may not be set up correctly</p>



My device does not turn off when I turn off my TV	Connected device may not be a CEC device
	Connected device may not support some or all CEC features
	CEC control may not be set up correctly
My TV does not turn on when I turn on my device	Connected device may not be a CEC device
	Connected device may not support some or all CEC features
	CEC control may not be set up correctly

Warning

This content is compiled from multiple sources and is provided for reference purposes only. It may not be complete or fully applicable to all situations. If you are unable to resolve your issue, please contact the product manufacturer or an authorized service provider for official support.