

INSTALLATION INSTRUCTIONS

GAS CONNECTIONS (All Units)

NOTICE TO MASSACHUSETTS APPLIANCE DEALERS:

Be sure this document is included in all gas range appliances sold to consumers in the State of Massachusetts.

NOTICE: Massachusetts law requires the following:

- Appliances must be installed by a licensed plumber or gas fitter.
- Appliances must be connected with three (3) foot (36" maximum length) flexible gas connector and
- A "T" handle type manual gas valve in the gas supply line to the appliance.

Have the dealer where you purchase your new range install it or have him recommend a qualified installer. Installation must conform with local codes. In the absence of local codes, the installation must conform with the National Fuel Gas Code, ANSI Z223.1- Latest Edition in the U.S.A. or the CAN/CGA B149.1 or .2 Installation Codes in Canada.

The range should be connected to the supply line with 1/2-inch black iron pipe or a certified flexible type stove connector. To prevent gas leaks, put an approved sealing compound, which is resistant to liquefied petroleum gases, on all threaded connections.

Important: Do not apply pressure directly to the range manifold pipe when tightening supply connections. The manifold pipe should be held securely at the pressure regulator to prevent twisting. Hold the pressure regulator with a wrench during the tightening of the connection, or the manifold pipe may be twisted and split, and cause a dangerous leak.

The installation of ranges designed for manufactured (mobile) home installation must conform with the Manufactured Construction and Safety, Title 24 CFR, Part 3280, formerly the Federal standard for Mobile Home Construction and Safety, Title 24, HUD Part 280]] in the U.S.A. or C.S.A. Standard CAN/CGA Z240.4.2 in Canada or, when such standards are not applicable with local codes.

The installation of ranges designed for recreational vehicle installation must conform with state or other codes or, in the absence of such codes, with the standard for recreational vehicles. ANSI A119.2.2-1982 in the U.S.A. or CAN/CGA Z240.4.2 in Canada.

The installation of appliances designed for recreational park trailers must conform with state or other codes or, in the absence of such codes, with the standard for recreational park trailers, ANSI A119.5.

Note: Check all piping connections in the unit for leaks. Never use an open flame to check for gas leaks. Use a soap solution. It is not impossible for connections made at the factory to leak, due to vibration encountered in transportation. Make certain you have checked them all, and repair any connections that leak.

The appliance and its individual shut-off valve must be disconnected from the gas supply piping system during any pressure testing of that system at test pressures in excess of 1/2 psig.

The appliance must be isolated from the gas supply piping system by closing its individual manual shut-off valve during any pressure testing of the gas supply piping system at test pressures equal to or less than 1/2 psig

Electrical Connections

All electrical wiring and attachments are 60-cycle, 120 volts, 15 amp max. Your range is grounded with a three-conductor (three-prong plug) supply cord which will ground the range when plugged into a GROUNDED wall receptacle. If the backguard of the range has a clock or light, connect the cord from the backguard into the special terminal block located at the top of the main back directly under the backguard supply cord.

The appliance must be electrically grounded when installed in accordance with local codes, or in the absence of local codes, with the National Electrical Code, ANSI/NFPA No. 70 Latest Edition in the U.S.A. or the Canadian Electrical Code, C22.1; Part 1 in Canada, if an external electrical source is utilized.

BACKGUARD INSTALLATION INSTRUCTIONS

Gas Ranges

- A. Remove main top.
- B. Place the backguard on top of end panels at the rear of range.
- C. Connect the "disconnect plug", for power to backguard if equipped with electrical features. See No. 1.
- D. Insert machine screws through lower inside flange of end caps and end panels. Secure with the hex nuts provided. (See No. 2).
- E. Insert machine screws through elongated holes (See No. 3) at bottom of backguard and side flanges of burner box. Secure with the hex nuts provided. F. Attach lower edge of backguard to vent outlet with two sheet metal screws. (See No.4)

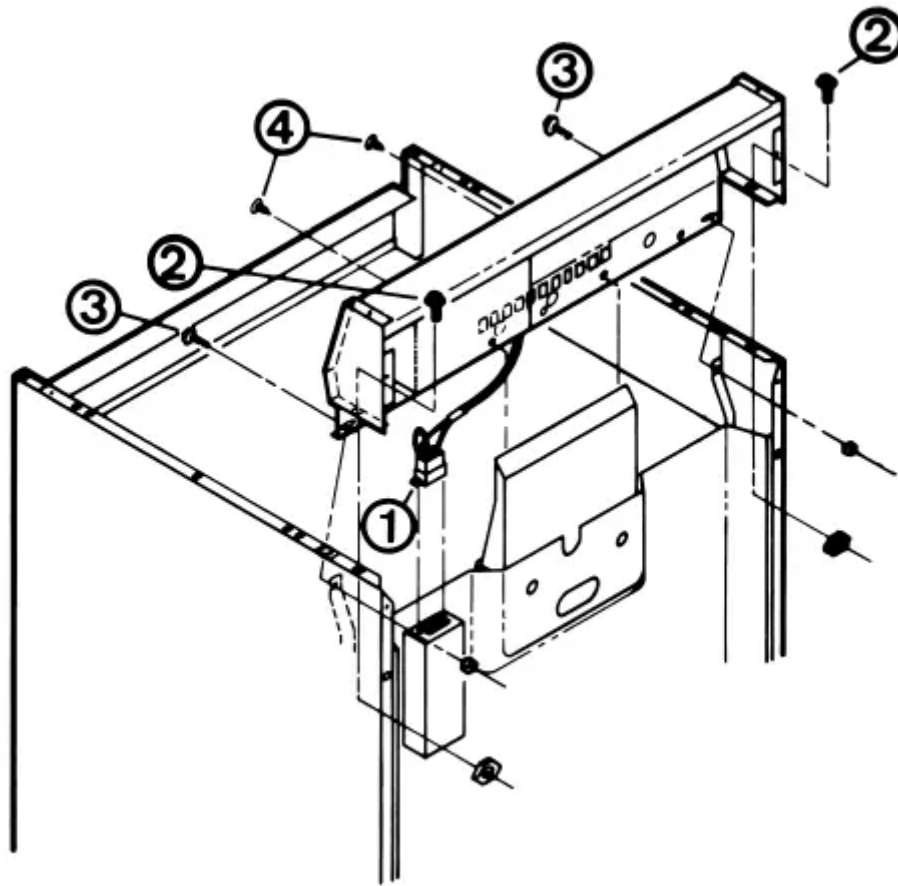

WALL CLEARANCES

All units must be installed in accordance to minimum rear and side wall clearance and clearances extended vertically above cooking top which are stated on the serial plate. (The serial plate is located below the cooktop.)

ANY OPENINGS IN THE WALL BEHIND THE UNIT AND IN THE FLOOR UNDER THE UNIT MUST BE SEALED.

Note. Due to potential hazards it is recommended that storage cabinets not be installed above the cooking surface.

IN THE EVENT OVERHEAD CABINETS ARE INSTALLED, THE MAXIMUM DEPTH OF CABINETS INSTALLED ABOVE COOKING TOPS SHOULD BE 13".

CABINET CUT OUT FOR FREE-STANDING MODELS

RANGE SIZE	"B" DIM.
20"	20 ^{3/8} "
24"	24 ^{3/8} "
30"	30 ^{3/8} "
36"	36 ^{3/8} "

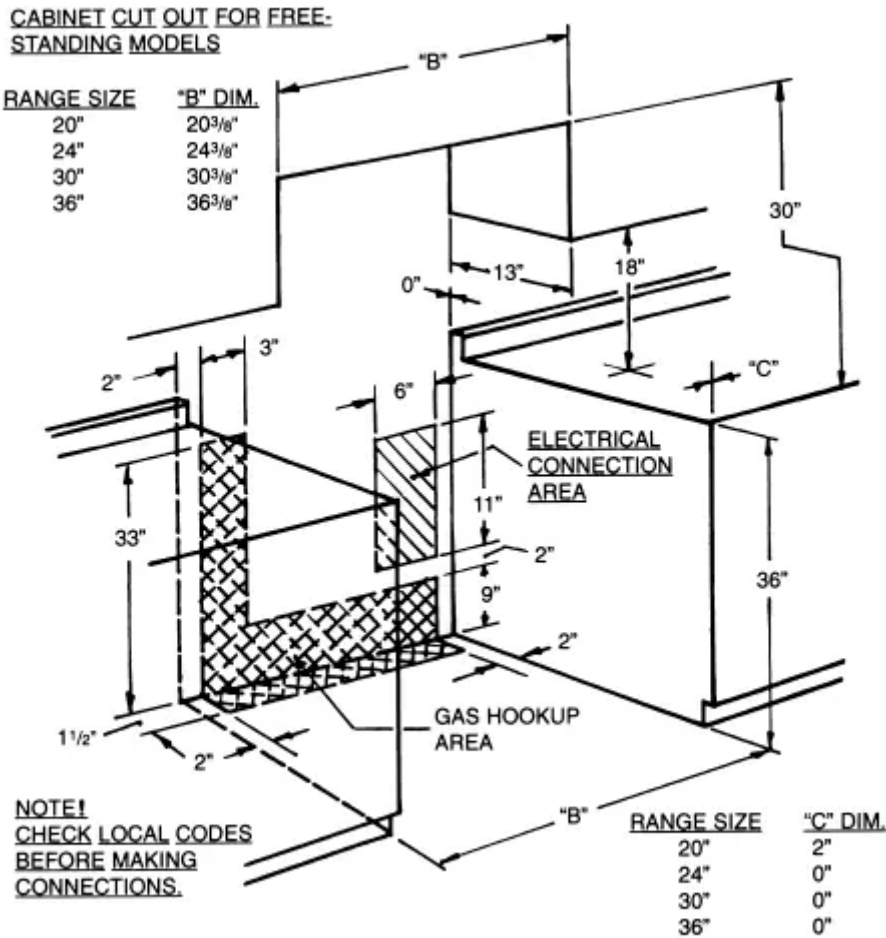

ALIGNMENTS AND ADJUSTMENTS

Installation

It is the responsibility of the installer to make certain that the range is properly adjusted at the time of installation. Situations caused by improper adjustments or improper installation are not covered under the warranty. Any expenses incurred due to such situations will not be paid by the manufacturer of the appliance.

Gas Range Conversion and Adjustment Guide

The range will either be set for use with Liquefied Petroleum (LP) or Natural Gas. The factory setting is indicated on the serial plate. When set for Natural Gas operation, the pressure regulator will regulate the pressure to 4 inches water column. When set for LP Gas operation, the pressure regulator will regulate the gas to 10 inches water column pressure.

On sealed burner models the main top must be removed to adjust regulator, burner orifices and thermostat from NAT to LP (propane) or vice versa. See illustration.

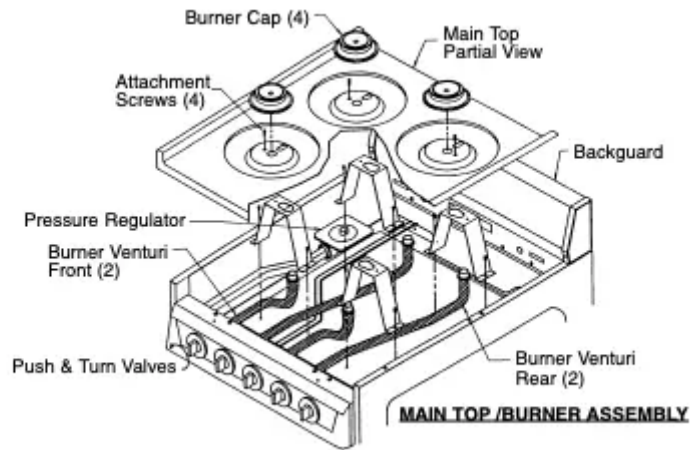

MAIN TOP / BURNER ASSEMBLY

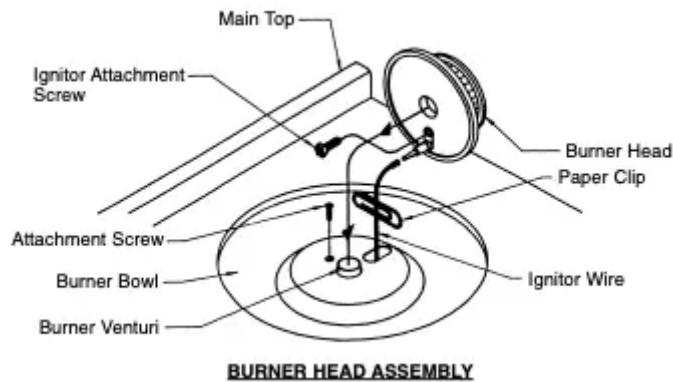

BURNER HEAD ASSEMBLY

To Convert and/or Adjust

1. Convertible Pressure Regulator

The inlet pressure of the gas supply shall be in accordance with the nominal inlet pressure of the regulator used on the range or 1/2 psig maximum. The range should be tested by pressurizing the regulator with an inlet pressure at least 1 inch water column above the manufacturer's specified manifold pressure shown on the serial plate. The range will be equipped with one of the two types of regulators shown.

For a Harper-Wyman regulator, remove converter cap by inserting a coin into slot in top and twisting. Turn cap over and re-install.

On the SCP regulator, unscrew the converter using a 5/8" wrench. Turn the cap over and reinstall.

On the Maxitrol regulator, unscrew the brass converter cap using a 7/8" wrench. Turn the selector pin over and re-install.

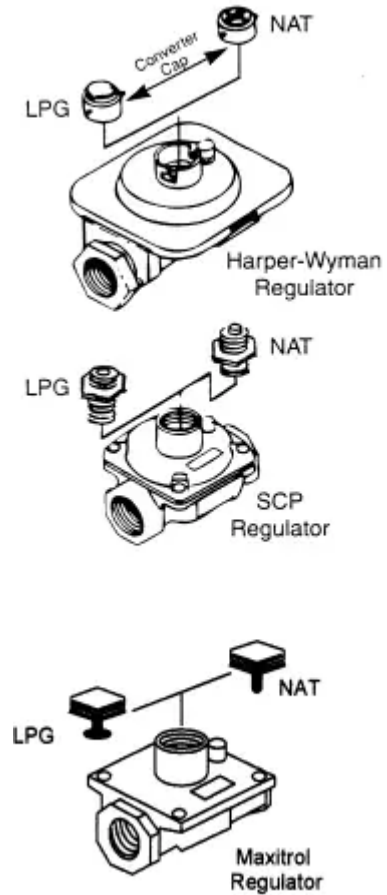

Note: What you read on the converter cap or plunger is the type of gas for which the regulator is set. If yours reads NAT, the regulator is set for natural gas. If yours reads LP, the regulator is set for LP.

2. Top Pilots (Gas)

The top burner pilots on floor mounted ranges can be adjusted by a screw located on the back of the thermostat at the pilot filter. Adjust the pilot flame until there is only a tip of yellow on the flame. Pilots are constant burning. **DO NO BLOW OUT FLAME WITHOUT TURNING OFF PILOT ADJUSTMENT SCREW.**

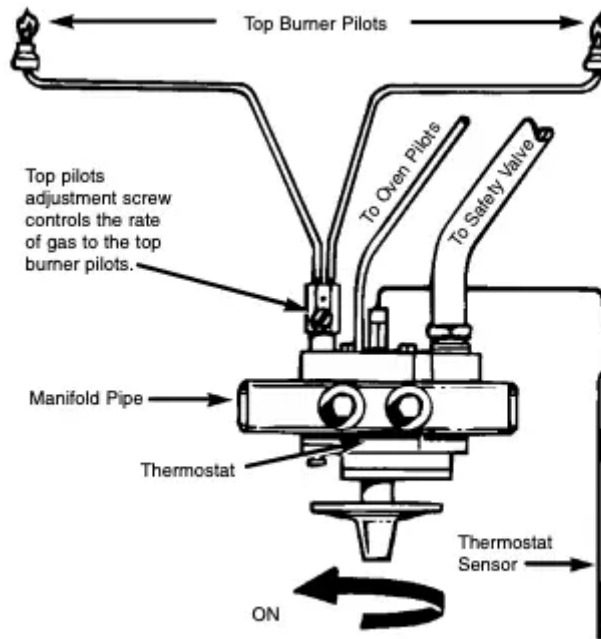

Top Pilots (Electric Ignition)

Ranges equipped with electric ignition will have the top ignitor electrodes in the same LOCATION as the familiar top burner standing pilots except for sealed burner models that employ an ignitor for each burner. (See page 13) When a top burner knob is turned to the LITE position ALL electrodes will spark at a rate of approximately 2 1/2 pulses (sparks) per second.

In the event of a power failure, light the top burners by holding a lighted match near the surface burner and turning on the surface burner.

WARNING

- Keep appliance area clear and free from combustible materials, gasoline, and other flammable vapors and liquids.
- Do not obstruct the flow of air that is necessary for combustion and ventilation.

3. Top Burner Valves

Adjusted by the opening or tightening of the orifice hood which is located on the valve where it attaches to the top burner. When set for LP gas the orifice hoods are screwed snugly on the valves. To adjust for Natural Gas: (A) Unscrew the orifice hoods until the proper flow of gas is obtained. (B) Adjust the air shutter, which is located on the throat of each burner, to obtain the proper mixture of gas and air to create the proper sharp blue flame without a red or yellow tip. The properly adjusted flame is approximately 3/4" high and has three distinct cones; the kindling point, the dark blue center cone, and the outer mantle.

Note: "Full on" flame size illustrated. The three position burner valve flame height in the "Low" position should be approximately 1/8" high. REMOVE SHIPPING SCREWS FROM TOP BURNERS.

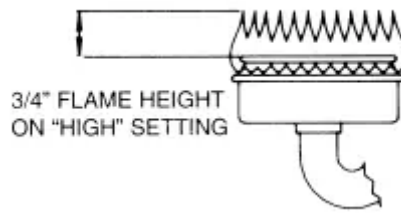

Standard Top Burner Valves

All top burner valves operate counterclockwise to open the valve and clockwise to close the valve. To ignite the gas, depress and turn valve knob all the way to the left to obtain full on" position, where the gas ignites automatically from the pilot flame or electrode.

By turning the valve knob toward "off" position, valve can be adjusted to many different heat settings which should be determined by the amount of food being cooked, the amount of liquid, or the size utensil.

Three Position Top Burner Valves

The range may be equipped with optional three position top burners valves. The three position burner valves have three distinct positions—Low, Medium and High. Adjust the burners in the "High" position for the proper mixture of gas and air as described in "Top Burner Valves." Then set the knob at the "Low" setting. Remove the knob to gain access to the adjustment screw which is located in the valve stem.

Hold the valve stem and turn the adjustment screw until the proper flame of approximately 1/8" is obtained. The adjustment of the "Low" position automatically adjusts the "Med" position.

Top Burner Height

Make sure the top burners are properly positioned. The top of the burner head should be level with the surface of the main top. To check, lay a straight edge such as a 12-inch ruler across the burner bowl opening. The ruler should rest squarely on the top while in contact with the burner head

If the burner is too high (make sure burner is cool), push it down. Supply enough force with the palm of your hand to accomplish this adjustment. To raise, pull up on the burner support at the center of the support.

4. Oven Control (Thermostat)

The oven pilot gas selector screw is located on this control. To change oven pilot gas setting: (A) Remove oven control knob by pulling straight out. The oven gas selector is found in the lower left hand corner indicating "LP" or "N". (B) These letters will appear upside down reading "N" and "LP." (C) Rotate the adjustment screw tab to the proper setting.

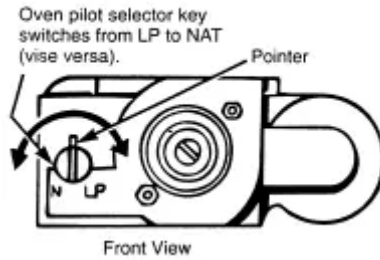

Oven Pilot (Light with the oven control knob in the OFF position). The oven pilot system has both a constant and a heater pilot flame. Because the system is a single pilot tube arrangement, both pilots receive their supply of gas through the same tubing. These pilots are pre-set.

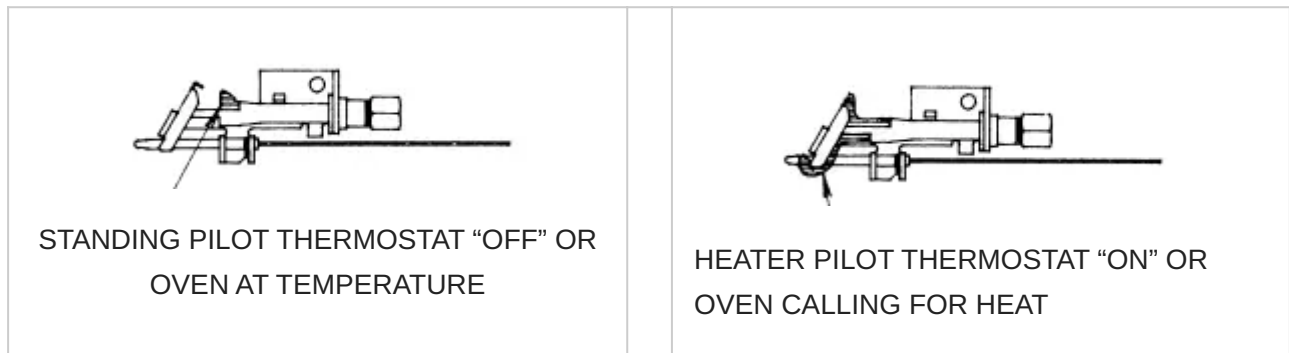

Heater Pilot

The heater pilot is an extension of the constant pilot. When the oven knob is placed in the bake or broil range, gas is increased to the constant pilot causing it to enlarge. It then becomes a heater pilot.

The heater pilot should impinge on the sensor bulb positioned at the pilot bracket. The sensor bulb is part of the automatic safety valve. When heated by the heater pilot (45 to seconds), the sensor should cause gas to be released into the burner and the burner should ignite. If at this point ignition doesn't occur, one of three situations has happened:

- 1. Bulb out of bracket; flame not impinging.
- 2. Burner not in proper position.
- 3. Defective automatic safety valve.

It is essential to maintain the gas pressure constantly at 10 inches water column pressure for ranges set for LP Gas; and 4" water column pressure for ranges set for Natural Gas to get proper pilot performance.

Note: Burner rates specified on the rating plate of your range apply for elevations up to 2,000 feet above sea level. For locations where altitudes are higher than 2,000 feet above sea level the b.t.u. rated input should be reduced four percent for each 1,000 feet higher than 2,000 feet above sea level. If this adjustment is necessary, you should contact a qualified serviceman. **DO NOT ATTEMPT TO SERVICE THE RANGE YOURSELF.**

Ovens with Pilotless Electric Spark Ignition: Free-Standing Ranges

Ranges equipped with the spark ignition system will have an oven pilot ignitor that has a flame sensing" feature that automatically stops the sparking once the oven pilot gas is ignited. Turning the oven control dial on will activate an electronic module and send pulses (sparks) to all electrodes (including the top burner electrodes) at a rate of approximately 1 1/2 pulses (sparks) per second.

MOISTURE: Moisture can have the same effect on the oven ignitor as the pilot flame. If sparking does not occur when the oven thermostat knob is turned on during the initial attempt to use the oven or after several days of non-use, it COULD BE the result of moisture build-up in the ceramic sleeve of the oven electrode. This may happen in areas with high humidity or if food having high water content is cooked. This moisture can be driven out of the ignitor by lighting the pilot and operating the oven for a few minutes. Follow the instructions below for lighting the pilot.

NEVER LEAVE THE CONTROL KNOBS IN ANY POSITION OTHER THAN "OFF" IF THE IGNITORS OR BURNERS AREN'T WORKING PROPERLY.

- With the oven control OFF open the broiler door and position yourself so you can see the oven pilot at the back of the oven burner.
- Next turn any top burner knob to the "LITE" position while watching the oven pilot. Turn the oven control on. If the oven pilot doesn't ignite within five seconds immediately turn the oven control off. If the oven pilot does ignite, the oven burner should ignite within 60 seconds. If not, immediately turn the oven control off and call a serviceman.

If the oven is working, to determine if moisture was the problem wait a few minutes and attempt to light the oven by turning the oven control dial on. If sparking occurs at the oven electrode to ignite the oven pilot and within sixty seconds ignites the oven burner then moisture build-up was the problem. If the oven burner doesn't ignite within 60 seconds turn the oven control off and call the serviceman.

- If for some reason there isn't sparking, indicating the module isn't working, or there is a power failure and oven cooking is necessary you may manually light the oven.

CAUTION: Make certain the oven is cool when manually lighting oven pilot.

- Open broiler door. Oven pilot is located on the left side of the oven burner at the back of the burner.
- Hold a lighted match and reach through the broiler compartment to the oven pilot.
- While holding the lighted match near the tip of the pilot assembly, turn the oven control dial to an ON position. Immediately remove your hand from the broiler compartment after the pilot gas ignites. From 20 to 60 seconds after the pilot ignites, gas will flow to the oven burner and the burner will ignite.
- Close the broiler door.

- Set desired temperature.
- When cooking is finished, turn the Oven Temperature Control to OFF. This will shut off all gas to the oven.

CAUTION : IF THE OVEN BURNER DOES NOT IGNITE WITHIN 20 TO 60 SECONDS AFTER THE PILOT IS LIGHTED, TURN THE OVEN TEMPERATURE CONTROL TO OFF AND WAIT FOR POWER TO BE RESTORED. DO NOT ATTEMPT TO RELIGHT THE PILOT AGAIN.

If the oven does not function properly when the power is restored, or at any other time, call a serviceman to determine the source of the problem. DO NOT ATTEMPT TO SERVICE THE RANGE YOURSELF.

5. Automatic Oven Safety Valve

The orifice hood on the oven safety valve regulates the flow of gas to the oven burner. This valve adjusts in the same manner as the top burner valves and is located at the base of the oven burner in the broiler compartment of the range. To gain access, simply remove the broiler section. When set for LP, the orifice hood is screwed snugly on the valve. To adjust for use on Natural Gas, unscrew the orifice hood until the proper flow of gas is obtained.

6. Oven Burner Air Shutter Adjustment

The oven burner flame should be a clean, blue flame with distinct inner cones approximately 1/2 inch long. A soft, lazy flame with indistinct cones means too much gas or not enough air. A noisy lifting flame means too much air. If adjustments are necessary you must first loosen the lock screw located at the top of the air shutter, then rotate the air shutter to the correct setting, and retighten screw.

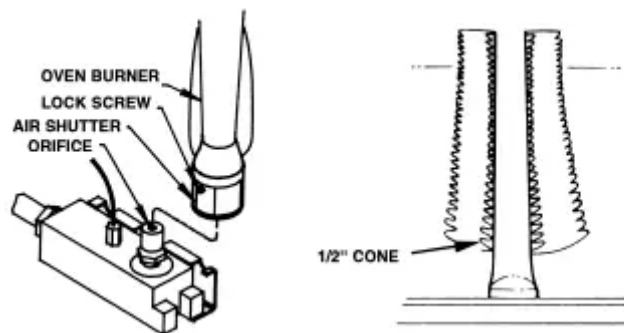

Oven burner flame can be checked as follows (without burner baffle in place):

- To correct a yellow flame-Increase size of air shutter opening.
- To correct a lifting, but distinct, blue flame-Decrease size of air shutter opening.

The air shutter should be set approximately 2/3 open for natural gas, and approximately full open on LP gas.

The oven burner air shutter adjustment is the same on ranges with a gas pilot or electric ignition.

Ovens with Pilotless Electric Ignition: Glow Bar Ignition System (-7 Models)

System Operation

The glow-bar ignition system consists of three main components:

- 1. The thermostat (or range control).
- 2. The glow-bar ignitor.
- 3. The oven gas valve (also called the safety valve).

The thermostat, ignitor and gas valve are wired in series.

When the thermostat knob is turned to a selected setting, this closes a set of electrical contacts in the thermostat applying power to the series circuit.

With power applied, the ignitor begins to heat. The electrical resistance of the ignitor will decrease as the surface temperature of the ignitor increases.

Current flowing in the circuit increases in proportion to the drop in ignitor resistance.

The NORTON ignitor limits the operating current flow in the circuit to 3.3 to 3.6 amps.

When the current has risen high enough to open the valve, the surface temperature of the ignitor is between 1800 to 2500 degrees F.

As gas flows out of the valve and into the burner a portion of the gas flows across the hot ignitor and ignition occurs.

The ignitor will remain energized when the burner is lit. Once the oven reaches the selected temperature, the thermostat contacts will open and remove power from the ignitor/valve circuit. The valve will then close after a few seconds and the burner flame will go out.

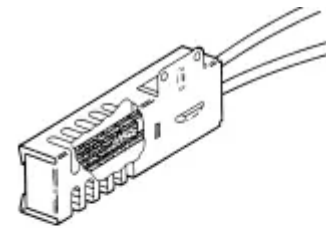

NORTON GLOWBAR

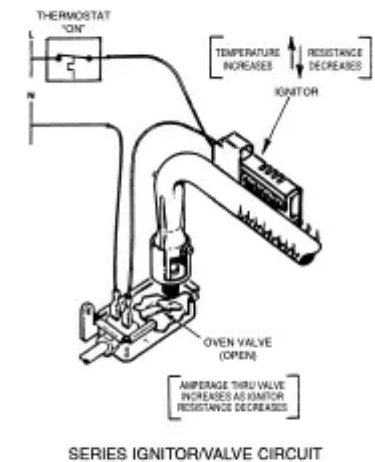

SERIES IGNITOR/VALVE CIRCUIT

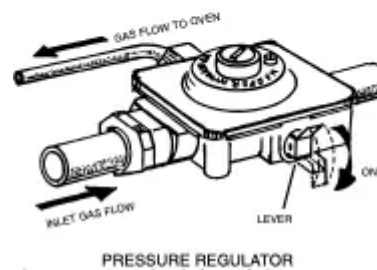

PRESSURE REGULATOR

Pressure Regulator

The pressure regulator, located on the left side of the range, at the inlet of the gas range piping system, serves two functions.

- 1. Controls the flow of gas to the gas piping system. It maintains a constant pressure of 4" water column on natural gas and for LP gas, if equipped, 10" of water column.
- 2. Incorporates a "shut-off" valve on some models on the gas supply system. This valve, located on the opposite side of the oven supply tube incorporates a small "lever." When this lever is "up", no gas will flow to the oven. When "down" oven gas is on. If the ignitor glows and the oven won't come on, check this valve.

NOTE: Sealed burner models have a "shut-off" located at the safety valve in the rear of the broiler area. Turn the handle on the brass valve fully clockwise to close off gas.

OPERATION OF RANGE

Using Your Range

The range may have only part of the features described within this manual. If your range has some features which are not covered in this manual, these features will be covered in other enclosed literature.

Top Burner Operation

Note: When boiling food, the highest temperature that can be reached is the boiling point.

When the liquid starts to boil, decrease the size of the flame until you reach the minimum flame that will hold the boil. This will save gas. It will also lessen the possibility of burning food or boiling food over, and help to keep your kitchen cooler. Use stable utensils with flat bottoms and always place the utensil on the burner grate before lighting the burner. Unstable or rounded bottom utensils will not contact properly with the grate and will affect the cooking efficiency. Select utensils large enough to avoid spills, but remember, over-sized utensils (diameters exceeding 8 1/2") can cause the range finish to discolor, craze or chip. Damage caused by oversized utensils, such as those sometimes used in canning, are not covered by the warranty. The finish has been manufactured to a commercially acceptable standard and its condition is dependent upon the care of the user.

Top Burner Valves

The top burner flame size should be adjusted so that it does not extend beyond the edge of the cooking utensil. As a matter of safety, it's urged that you comply with these instructions.

A high flame on a surface burner is both inefficient and unsafe. The flame should always be adjusted so that it is no larger than the bottom of the pan. Fluctuations in flame size could be caused by pressure variations, improperly positioned burners, damage or debris.

Preheating

Heat the oven to the desired temperature before placing the food in the oven. Preheat for to 12 minutes.

Opening Oven Door

Let hot air or steam escape before removing or replacing food.

Arranging Oven Racks

The oven racks should be arranged before the oven is turned "ON." Place the racks so the food is centered in the oven..

Temperature Selection

It is important to select to proper temperature setting. Never set the dial to a higher degree than needed with the intention of lowering the setting at a later time. This will not speed up the action. It can cause the oven to cycle slower and cause the temperatures to vary so that cooking results may be unsatisfactory. Imagine that the control has three sections: Low Temperature, Bake and Broil.

The Low Temperature setting has a temperature range of 140°F to 200°F. This setting is used to keep food at serving temperature. The bake cycle is from 250°F to 550°F. This can be termed as the very low range (250°F to 275°F) to extremely hot (500° to 525°F). The moderate baking range is 350°F to 425°F.

Baking

When baking follow the recipe instructions. Use correct ingredients, measure them carefully, and use the correct type and size utensil suggested in the recipe. Remember to preheat properly. Avoid frequent opening of the oven door during preheating and baking.

When baking cakes in glass baking dishes, lower the oven temperature 25°F to prevent browning of the bottom and sides before the top becomes brown.

Also when using glass bakeware it would be better to increase the preheat time to have exact stabilization of the oven's temperature. To do so allow 20 minutes time for temperatures up to 350°F and 30 minutes for temperatures up to 425°F. Avoid opening the door as much as possible.

Oven Racks

The oven racks should be arranged before the oven knob is turned to an "ON" position. Place the racks so the food is centered in the oven, not the rack.

When more than one utensil is used, be sure to stagger them allowing space between each one. Do not allow the utensil to touch any part of the oven, especially the glass window. It is best to use two racks and place food so one utensil is not directly over another.

Rack Removal

Pull the oven rack forward and lift up on the front of the rack so it will clear the rack keeper.

To replace the oven rack, guide the angled rear portion of the rack under the rack keeper and slide the rack to the rear.

Never cover the oven racks with aluminum foil. Such practices will trap heat and cause intense heat in spots which usually give poor results. It can damage the porcelain finish as well as glass windows in oven doors (if equipped). 11-97

Removable Oven Bottom

First remove the racks from the oven. The oven bottom lifts from the rear. Grasp each side of the oven bottom and lift upward from the rear until the bottom is clear—lift it to remove from the front.

NOTE: If the oven bottom is replaced incorrectly it may warp and cause undesirable baking results.

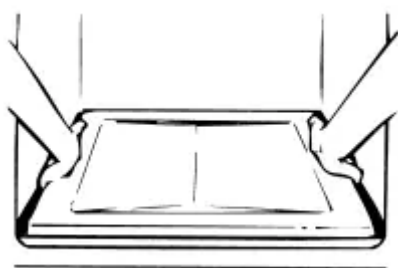

The oven bottom has a porcelain enamel finish. To make cleaning easier, protect the oven bottom from excessive spillovers. This is particularly important when baking a fruit pie or other foods with high acid content. Hot fruit fillings or foods that are acidic in content, such as milk, tomato or sauerkraut, and sauces with vinegar or lemon juice, may cause pitting and damage to the porcelain enamel surface.

To protect the oven bottom surface, place a piece of aluminum foil slightly larger than the baking dish on the rack below to catch any boilovers. It should not completely cover the rack as this would cause uneven heat in the oven. Aluminum foil should not be placed on the oven bottom.

If a spillover does occur on the oven bottom, allow the oven to cool first. You can clean the bottom with soap and water, a mild abrasive cleanser, soap-filler abrasive pads or an oven cleaner following package directions.

Broiler Compartment

The broiler pan is held in place by a wire broiler rack. To open the broiler, gently lift up and pull forward on the drop down broiler door. Pull the broiler pan forward. It will reach a temporary stop

position. Continue to pull forward and the broiler pan will pull out to expose the entire broiler grill surface. Remove the broiler pan from the broiler rack by lifting up on the front of the broiler pan so it will clear the wire rack. Then pull forward slightly and use both hands to lift the pan free of the rack. To return the pan to the broiler rack, pull the wire rack out to the stop position. Insert the pan into the recessed section of the broiler rack. Slide the pan in place under the pan retainers. Push the pan to the rear of the broiler compartment. Close the broiler door.

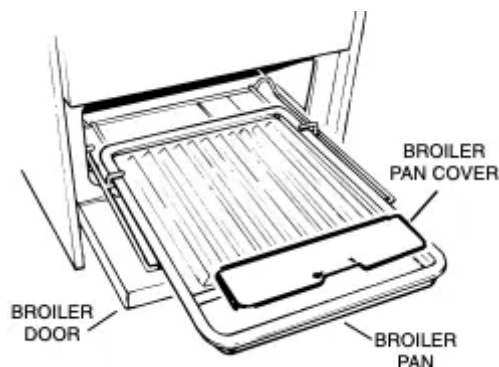

Economy Broiler

Your range may be equipped with this optional broiler. The outward appearance of the range will be the same. To open the broiler door, lift handle up slightly to release the door catch and then lower the door. In the broiler section there are two positions of stamped-in oven rack guides and a broiler pan and grill. When you want to broil, take one of the oven racks and insert it into the rack guide positions. Next, place the broiler pan and grill on the oven rack for broiling.

Broiling

Preheat the broiler area and broil pan for a few minutes. No definite time can be given for broiling meats because of varying thickness, amounts of fat, and personal taste. Be careful when handling hot broiler pans; be careful of the hot grease. Serious injury can result due to spillage of hot grease. Never leave a dirty broil pan in place, always clean it and return it to the broiler assembly. Unauthorized broil pan substitutes should never be used. Excess fat should be trimmed to reduce the possibility of flame up. The meat could be ruined or fire could occur causing loss of property and bodily injury.

When broiling fatty meats, the lowest broil must be used, however, we recommend the lowest positions at all times.

Always broil with the oven door closed. When broiling is completed, turn the dial to OFF and remove the broil pan temporarily for cleaning.

Do not use the broiler area for storage of utensils.

OPTIONAL EQUIPMENT

Continuous Cleaning Feature

If your oven has the continuous cleaning feature, it will have a dull gray finish with white speckles that has been blended with a special catalytic material. (If the oven has a glossy finish, it is standard porcelain enamel without the continuous cleaning feature.)

Before Using Your Oven—Read These Instructions Carefully.

Using The Continuous Cleaning Oven

The catalytic finish will keep your oven presentably clean with some effort on your part. Any time the oven is in use, the catalytic action will be working to eliminate normal cooking spatters. Simply cook as you usually do. Average oven spatters should fade away. If a great deal of spattering occurs during cooking, a small amount may remain on the surface of the oven interior at the end of the cooking time. This is particularly true during a short cooking cycle. The longer the cooking cycle, the better the catalytic action.

Cleaning time depends on the type, size and amount of soil, and oven temperature. The cleaning time will vary from a few minutes to several hours. The oven will never get completely clean—it will appear “presentably clean,” even though some stains or spatters may be present.

Heavy Spillovers—Unusual Stains

The continuous cleaning oven feature will make cleanups easy. However, some spills or food types are harder for the oven to clean without a little assistance. For heavy spillovers, such as from an overfilled fruit pie or casserole, put a cookie sheet or aluminum foil on the oven bottom. Be sure the foil does not cover the air openings, so do not extend foil beyond oven bottom.

If you should get a heavy spillover on the oven bottom:

1. Brush off heavy soil with a nylon brush or plastic pad. DO NOT USE paper toweling, cloths or sponge. Oven walls are porous and particles of these materials will rub off on walls. Rinse area well with clean water only. Do not allow insulation under oven bottom to become wet.
2. If spillovers harden before they can be wiped away, they may become either a brittle crust or a varnish-type coating. The brittle crusts will loosen and flake off in time. This process can be speeded up by GENTLY tapping crust with a wooden or plastic utensil and then brushing crust away.
3. Any remaining soil will gradually reduce with continued oven use at normal baking temperatures.

DO NOT USE ANY TYPE OF OVEN CLEANER, POWERED CLEANSERS, SOAP, DETERGENT OR PASTE ON ANY CONTINUOUS CLEANING SURFACE. ALSO, DO NOT USE ANY

ABRASIVE MATERIALS, STEEL WOOL, SHARP INSTRUMENTS OR SCRAPERS. THEY WILL DAMAGE THE FINISH.

Note: Over a period of time, wear marks may appear on the embossed rack supports. This is normal and results from sliding the oven racks in and out of the oven. Wear marks will not interfere with the overall cleaning action of the oven.

Backguard and Control Panel Features

WARNING Electrical Grounding Instructions: This appliance, when equipped with electrical equipment, has a three-prong grounding plug for your protection and should be plugged directly into a properly grounded receptacle. Do not cut or remove ground prong.

The backguard equipment is optional, depending on model selection. The range you have purchased may or may not be equipped with the features that are illustrated in this section. The clocks have been placed into separate groups.

CLOCK WITH TIMER

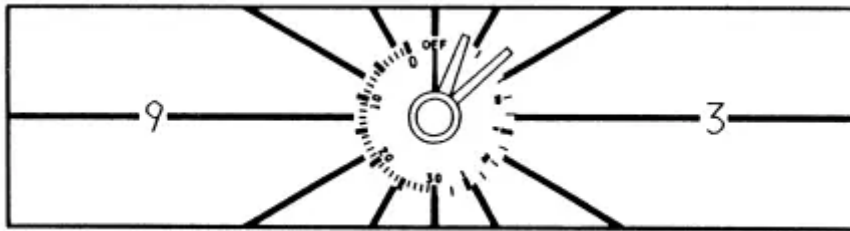

To set a dial type clock, PUSH IN on the knob and turn it to the correct time.

(**NOTE:** Release and then without pushing in rotate so that the timer hand is “OFF.” This should be done after setting the time.) To set timer don’t push in on the knob, simply rotate to the length of time you want. A signal will sound when the time has elapsed. To stop the signal rotate the knob to “OFF.”

DIGITAL CLOCK WITH TIMER

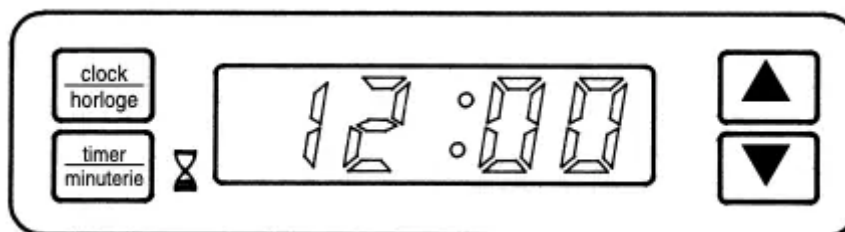

To set “time of day” press CLOCK. Press ▲ or ▼ to set correct time.

To set “cook time” press TIMER (0:00 WILL APPEAR). Press ▲ to set minutes (12 HRS IS MAXIMUM TIMER SETTING). Then press TIMER again. Colon starts blinking indicating timer is counting down.

To clear timer press TIMER.

To return to clock while timer is running, Press CLOCK.

CLEANING THE RANGE

Always keep cleaning materials and chemicals in a safe place and away from children.

Know what you are using. Make sure all parts of the range are COOL before cleaning. Be sure to replace the parts correctly.

Knobs

Pull forward on the knobs to remove them. Wash in a water solution with a mild detergent mix. Do not use an abrasive cleaner or any abrasive action. Abrasive action will scratch away the knob markings.

If the knobs become loose on the valve stem, spread the valve stem slightly with a small screwdriver.

Using Commercial Oven Cleaners

Commercial oven cleaners may be used on porcelain lined ovens; however, many cleaners are very strong, and it's essential to follow instructions carefully. Be sure to wear rubber gloves to protect your hands.

After using such cleaners, thoroughly rinse the oven with a solution of 1 tablespoon vinegar to 1 cup of water.

Oven cleaners can coat or damage the thermostat sensing device (the long tube in the oven) so that it will not respond to temperature accurately. If you use an oven cleaner, do not let it contact the sensing bulb, or any chrome, aluminum, or plastic part of the range. Do not apply or allow the cleaner to come in contact with any parts or surfaces other than the oven interior.

Grates, Main Tops, Surface Burners and Sealed Burners

The grates are made of porcelain coated steel. These materials can be cleaned at the sink with detergent or soap-filled scouring pads. Do not be alarmed when the grate loses its shining finish. The heat from the burners will cause the grates to lose their shining finish.

NOTE: Top burner grates must be seated in the proper position with the retainer lug in the hole provided for it. This will prevent the burner grate from rotating or tilting.

To remove the range top on standard models, first remove the grates. Lift up the front of the main top, then grasp the top at each side and pull it toward you. On sealed burner models, you must first remove the burner grates and burner heads.

When removing the burner head/s, the ignitor wire must be disconnected and secured in some fashion, paper clip, tape, etc., to keep it from falling through the access hole in the main top. Never immerse the ignitor in water. This can cause ignition problems. Clean the burner head with a non-abrasive soap filled scouring pad, rinse thoroughly and dry completely before reassembling. Burner heads can be dried in the oven at about 350 degrees Fahrenheit or in the dishwasher on the dry cycle. If there is a need to remove the main top, remove the four (4) attachment screws shown on page 13. After adjustment or cleaning, replace all parts to their original position. Care should be taken when connecting the ignitor wire as the ceramic ignitor base could be damaged. See page 13 for instructions.

The porcelain finish top can be cleaned with detergent and warm water. A mild glass wax can be used to shine the top.

Range tops finished in brushed chrome should be wiped clean of spatters or soiling after each use. Clean with a paper towel or a damp cloth. For heavy spatters, use a mild detergent and water. Wipe dry with a soft cloth.

A light coat of oil or thin cooking oil should be applied periodically to the chrome top surface and underside. This will help prevent moisture from penetrating the chrome surface.

Products of combustion from the top pilots as well as certain atmospheric conditions can create an oxidation reaction on the underside of the top. This will appear as rust or in the form of a reddish brown deposit. This will NOT AFFECT THE LIFE OF THE TOP in comparison to the general life expectancy of the range itself.

The grate and main top should be removed to gain access to the surface burners. Remove the burner and let it soak in hot sudsy water. Most stains will then wipe off; if not, scrub with a strong but non-abrasive cleaning pad. Rinse the burner thoroughly.

It is very important that the burner be dry before replacing it in the range. A wet burner will not allow the gas to ignite properly. This could result in a build-up of gas which could result in an explosion or fire.

Aluminum Foil in Oven and Broiler

Aluminum foil when used improperly is a cause of many range fires. Make certain that vents or air openings aren't covered by the foil. If the vents located along the sides of the oven bottom are blocked, poor cooking will result.

Never cover a rack completely. A piece of foil slightly larger than the utensil can be placed on the rack beneath the utensil.

Remove and discard aluminum foil after each use. This will help prevent greases and spilled food from accumulating and becoming a fire hazard.

Cleaners and Cleaning Materials

Do not use harsh cleaners or degreasers on or around functional parts (valves, controls, etc., or aluminum tubing). This will damage or drastically reduce the life of the part.

Use only a mild solution of soap and water on backguards, aluminum control panels and painted surfaces. Never use harsh abrasives or cleaning powders that may scratch or mar the surface. Make sure the cleaners and cleaning materials are suitable for use on the area to be cleaned. Always keep cleaning materials in a safe place. Never use a sharp metal scraper to clean glass, porcelain, or painted surfaces.

Repair Parts

When repair parts are needed, contact the dealer from whom the range was purchased. In case your range was purchased from a source other than an appliance dealer you may prefer to contact the manufacturer at the address shown in this manual.

Moisture

During the initial heat-up of your range, the heat mixing with the cooler air in the oven cavity may produce fogging of the door glass or a collection of water on the door. To prevent this, open the oven door for the first few seconds of initial oven heat-up. This will allow the moist air within the oven to escape without the forming of visible moisture on the range. The amount of moisture will depend upon the humidity of the air and water content of the food being cooked. Fogging and even dripping water will usually occur in geographic locations of high humidity

LIFT-OFF DOORS

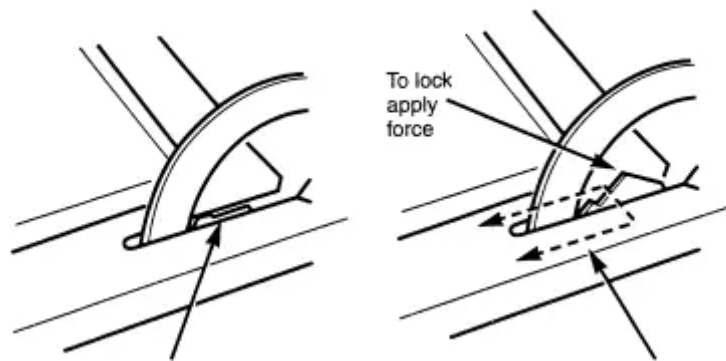

Locking mechanism lever To unlock apply force

Lift-Off Oven Door (on some models)

The oven door is removable (on some models) but it is heavy. You may need help removing and replacing the door.

To remove the door, open it to the full open position. Raise the locking mechanism by applying force to the locking mechanism lever. Close the door until it stops against the locking mechanism. Grasp firmly on each side and lift the door straight up and off the hinges.

To replace the door, position the slots in the bottom of the door squarely over the hinges.

Then lower the door slowly and evenly over both hinges at the same time. Open the door to the full open position and press the locking mechanism back into its original position.

DO NOT ATTEMPT TO CLOSE THE DOOR UNTIL THIS STEP IS COMPLETE. THE HINGE OR DOOR COULD BE DAMAGED.

TROUBLE SHOOTING GUIDE



PROBLEM	CAUSE	CORRECTION
<p>1. Surface burner fails to light.</p>	<p>a. Pilot is out. b. Range not connected to power supply (Solid State Ignition). c. Burner incorrectly rated d. Clogged burner ports. e. Top burner not properly positioned</p>	<p>a. Relight pilot. b. Connect range to wall outlet, check circuit breaker or fuse box. c. Have serviceman rate burner. d. Clean ports in proper position on valve and burner hanger. e. Reposition burner.</p>
<p>2. Uneven flame.</p>	<p>a. Clogged burner ports. b. Uneven burner alignment.</p>	<p>a. Clean ports with straight pin. b. Align burner.</p>
<p>3. Surface burner flames</p> <ul style="list-style-type: none"> •Lifts off port. •Yellow in color. •Noisy when turned off. 	<p>a. Improper air gas mixture.</p>	<p>a. Have serviceman adjust burner -Or- Remove pan from burner. (Pan obstructs free air flow. Try again.)</p>
<p>4. Pilot goes out.</p>	<p>a. Burner and/or pilot incorrectly adjusted.</p>	<p>a. Have serviceman adjust burner.</p>
<p>5. Oven does not light.</p>	<p>a. Pilot is out. b. Range not connected to power supply (Solid State Ignition). c. Moisture build-up in ceramic sleeve of oven electrode.</p>	<p>a. Relight pilot. b. Connect range to wall outlet. Check circuit breaker or fuse box. c. See Moisture in ALIGNMENTS AND ADJUSTMENTS section. d. Check selector screw. See step 4 in ALIGNMENTS AND ADJUSTMENTS section. e. Set indicator in MANUAL (MAN) or OFF position.</p>



	<p>d. Gas selector screw incorrectly set.</p> <p>e. Oven not set correctly.</p> <p>f. Oven calibration or burner out of adjustment.</p>	<p>f. Have servicer adjust burner.</p>
<p>6. Oven Temperature seems inaccurate.</p> <ul style="list-style-type: none"> •Food takes too long. •Food cooks too fast. •Food pale in color. •Overbrowning •Overdone on outside and underdone in center. 	<p>a. Oven was not preheated.</p> <p>b. Incorrect rack position</p> <p>c. Incorrect use of aluminum foil.</p> <p>d. Oven bottom incorrectly in place.</p> <p>e. Used incorrect type of utensil.</p> <p>f. Oven Calibration or burner out of adjustment.</p>	<p>a. Preheat oven 10 minutes.</p> <p>b. Refer to Use of Oven Section.</p> <p>c. Refer to section on aluminum foil.</p> <p>d. Replace oven bottom correctly.</p> <p>e. Use shiny pans for cakes,cookies and biscuits. Use dull or glass utensils for pies and breads. Dark pans absorb heat and cause over-browning.</p> <p>f. Have serviceman calibrate oven and adjust burner.</p>
<p>7. Range clock and/or lights do not work.</p>	<p>a. Range not connected to power supply.</p> <p>b. Burned out bulb.</p> <p>c. Defective switch, starter, or ballast. (Fluorescent bulb.)</p> <p>d. Clock defective, loose wiring or connection.</p>	<p>a. Connect range to outlet, connect backguard plug, check circuit breaker or fuse box.</p> <p>b. Replace bulb.</p> <p>c. Replace starter or ballast. Have serviceman replace switch.</p> <p>d. Have serviceman check clock assembly or loose connection.</p>

Warning



This content is compiled from multiple sources and is provided for reference purposes only. It may not be complete or fully applicable to all situations. If you are unable to resolve your issue, please contact the product manufacturer or an authorized service provider for official support.

Document generated by [ManualsFile](#)

