

## OPERATING INSTRUCTIONS

### Features

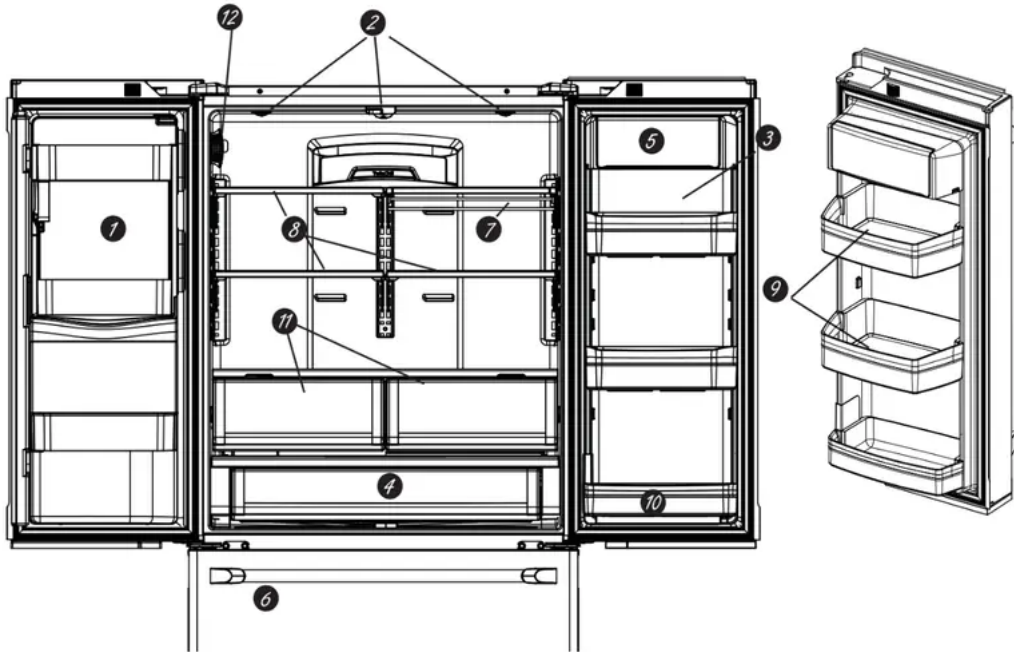

#### **1 Space-saving ice maker\***

Ice maker and bin are located on the door creating more usable storage space.

#### **2 Showcase LED lighting**

LED lighting is positioned throughout the interior to spotlight areas in the refrigerator. LEDs are located under the fresh food door to light the freezer when opened.

#### **3 Drop-down tray\***

Allows for extra door storage when you need it and tucks away when you don't.

#### **4 Full-width temperature controlled drawer**

Adjustable temperature control bin that can accommodate larger items.

#### **5 Dairy bin**

Separate compartment for your items.

#### **6 Ice bin/Ice maker\***

Ice maker with ice storage bins.

#### **7 QuickSpace™ shelf\***

Functions as a normal full-sized shelf when needed and easily slides back to store tall items below.

### **8 Spillproof shelves**

Designed to capture your spills for easier clean up.

### **9 Anti-slip Mat**

Liner that captures spills, keeps containers from shifting when the door is opened and is easily removable for cleaning.

### **10 Removable door bin**

Can be removed for those with a wall limiting the door opening.

### **11 Climate zone bin**

Separate bins for produce storage.

### **12 Water filter**

Filters water and ice.

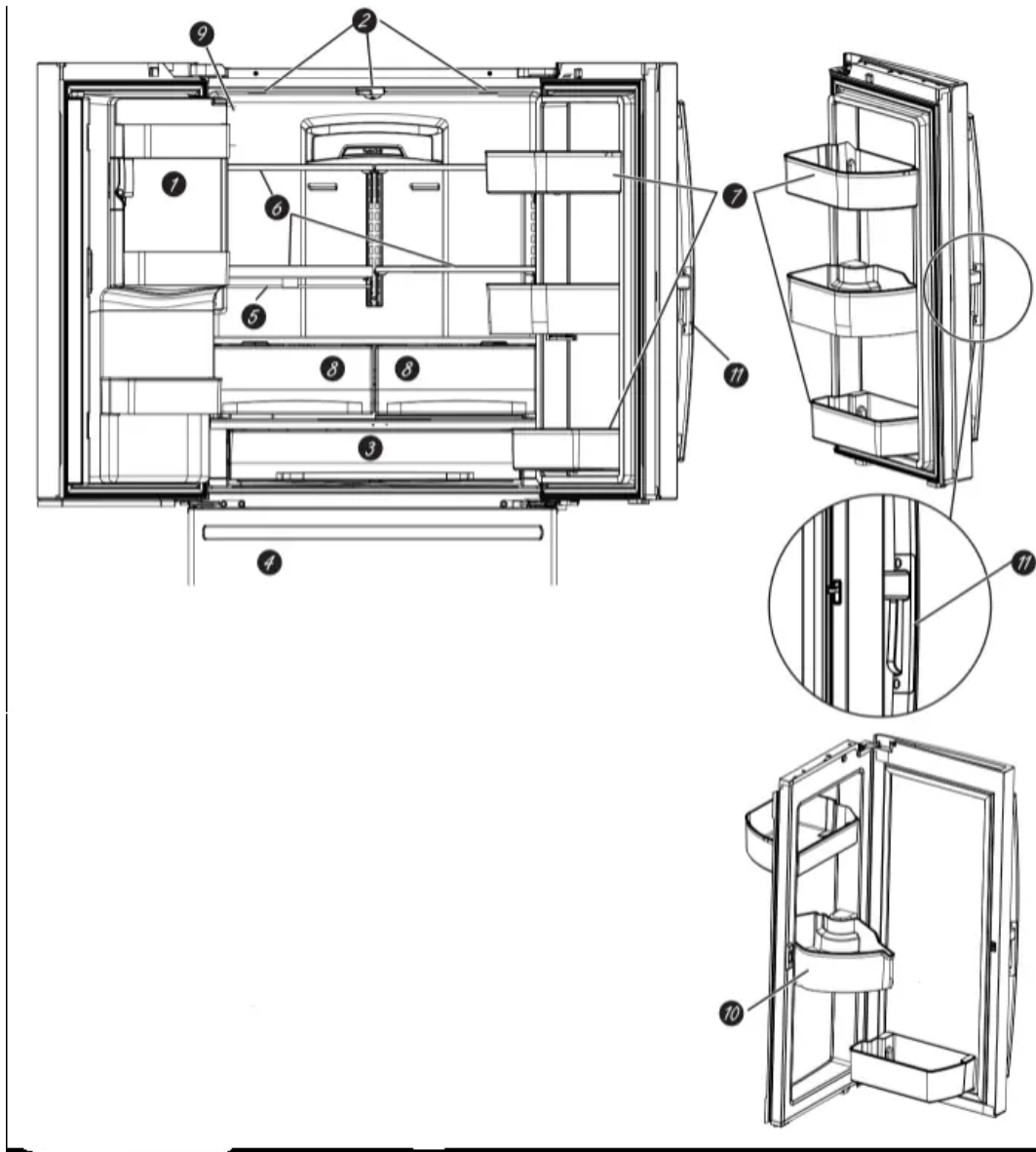

### 1 Space-saving ice maker\*

Ice maker and bin are located on the door creating more usable storage space.

### 2 Showcase LED lighting

LED lighting is positioned throughout the interior to spotlight areas in the refrigerator. LEDs are located under the fresh food door to light the freezer when opened.

### 3 Full-width temperature controlled drawer

Adjustable temperature control bin that can accommodate larger items.

### 4 Freezer Ice maker bin®

An ice maker in both compartments give you more ice whenever you need it Available on Non-Dispense models, also available as a kit for some models.

### 5 QuickSpace™ shelf\*

Functions as a normal full-sized shelf when needed and easily slides back. to store tall items below.

### **6 Spillproof shelves**

Designed to capture your spills for easier clean up.

### **7 Removable door bin**

Can be removed for those with a wall limiting the door opening.

### **8 Climate zone bin**

Separate bins for produce storage.

### **9 Water filter**

Filters water and ice.

### **10 Rotating Bin\***

Can be rotated out for easy access.

### **11 Door in Door Latch\***

Squeeze the latch on the underside of the handle to open the inner door.

### **1 Door ice bin\***

1. Open left fresh food door.
2. Pull down latch to release bin door.
3. Using handhold lift ice bucket up and out to clear locators in bottom of bin.
4. To replace the ice bucket, set it on the guide brackets and push until the ice bucket seats properly.
5. If bucket cannot be replaced, rotate the Ice Bucket Fork 1/4 turn clockwise.

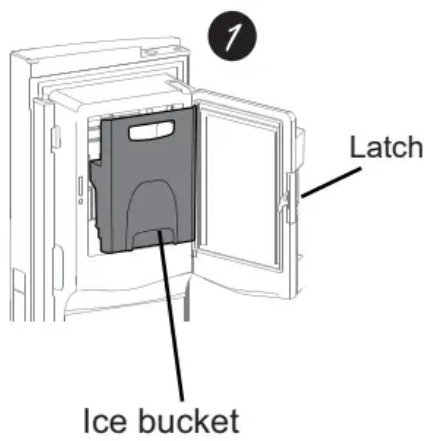

## 2 Ice/water filter

Certified to reduce chlorine-resistant cysts, lead, select pharmaceuticals, and more. For easyfilter replacement instructions see page 17.



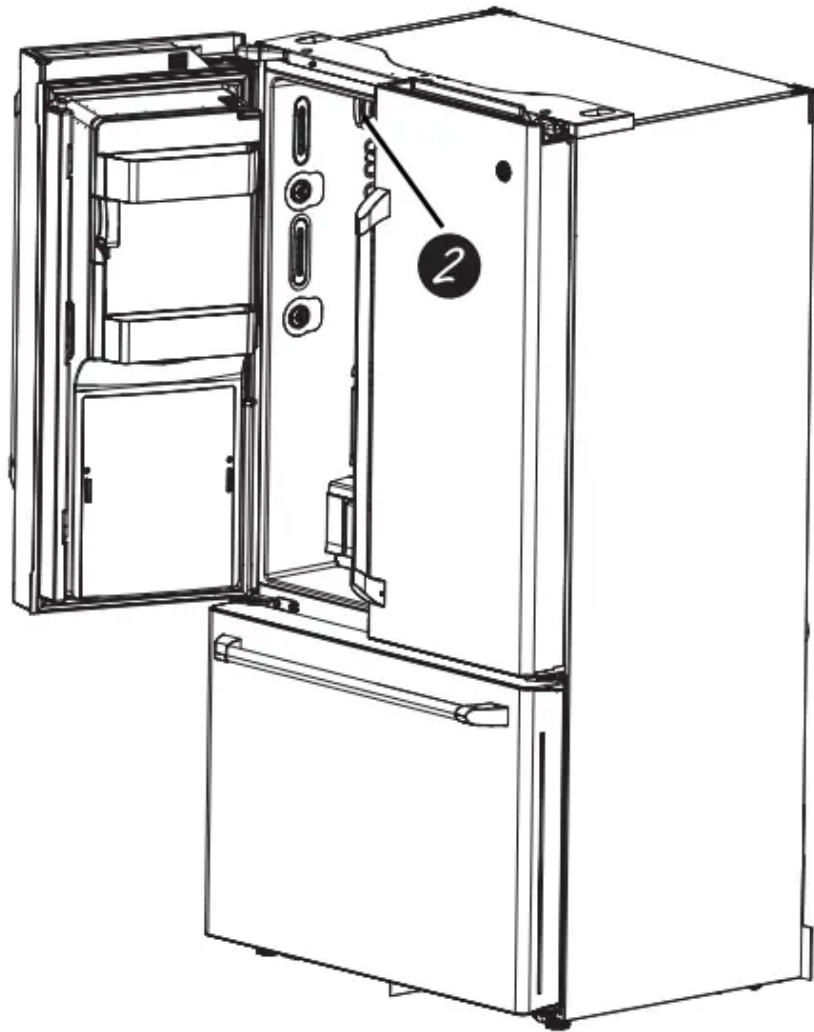

**Controls**

**PFE28P, PYE22P Control Style A, Single Serve Models**

<p><b>Fridge</b> Turbo Cool Hold 3 Sec</p>	<div style="display: flex; justify-content: space-between;"> <div style="text-align: center;"> <p>-88°F 88°C</p> <p>Set Temp</p> </div> <div style="text-align: center;"> <p>88 Oz 88 %</p> <p>Days Remaining Overdue</p> </div> </div> <div style="text-align: center; margin-top: 10px;"> <p>Warning Brew very hot Replace Filter Dispenser Off</p> <p>Ice Maker ON OFF Alarm ON OFF Control Locked Hold for 3 sec</p> <p>Error Cubed Crushed</p> </div> <div style="text-align: center; margin-top: 10px;"> <p>Coffee Cocoa</p> <p>Heating Dispense Error</p> </div>	<p><b>Start Heating</b> Cancel Hold 3 Sec</p>		
<p><b>Freezer</b> Turbo Freeze Hold 3 Sec</p>		<p><b>Brew Size</b> Cocoa Hold 3 Sec</p>		
<p><b>Door Alarm</b> Control Lock Hold 3 Sec</p>	<p><b>Water</b></p>	<p><b>Ice</b> On/Off Hold 3 Sec</p>	<p><b>Light</b></p>	<p><b>Brew Dispense</b> Hold 3 Sec</p>



**PFH28, PFE28K, DFE28, PFD28, PYE22K, PYD22, DYE22**  
Control Style B, AutoFill Models

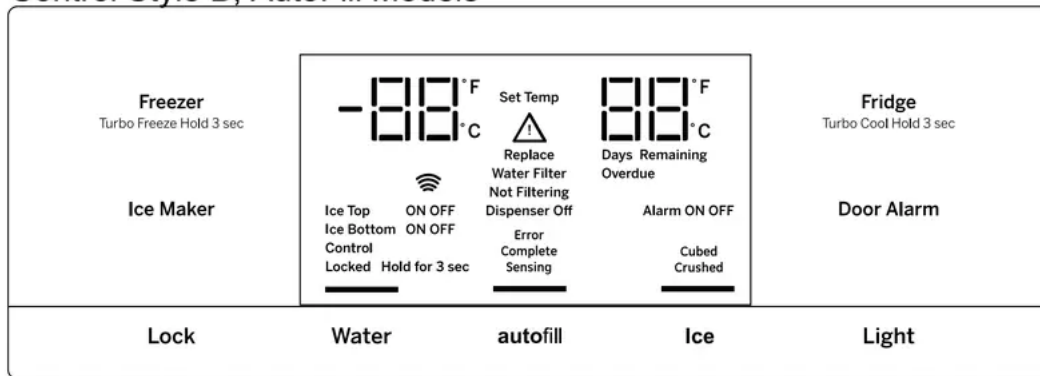

**GFD28, GFE28, GFE26, GFS26, GYS22, GYE22** Control Style C, GE Models

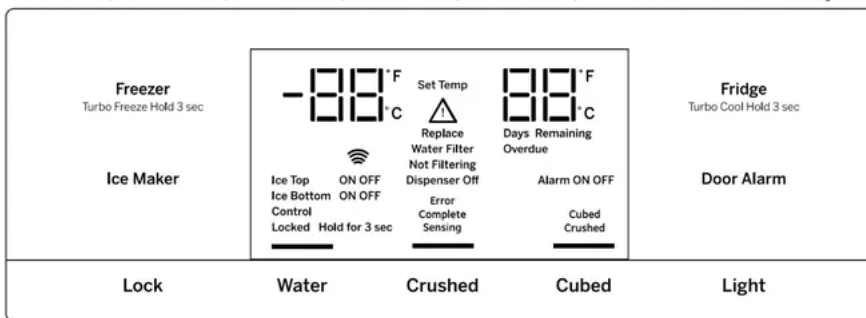

**GNE29, PWE23 Control Style D, Non-Dispense Control**

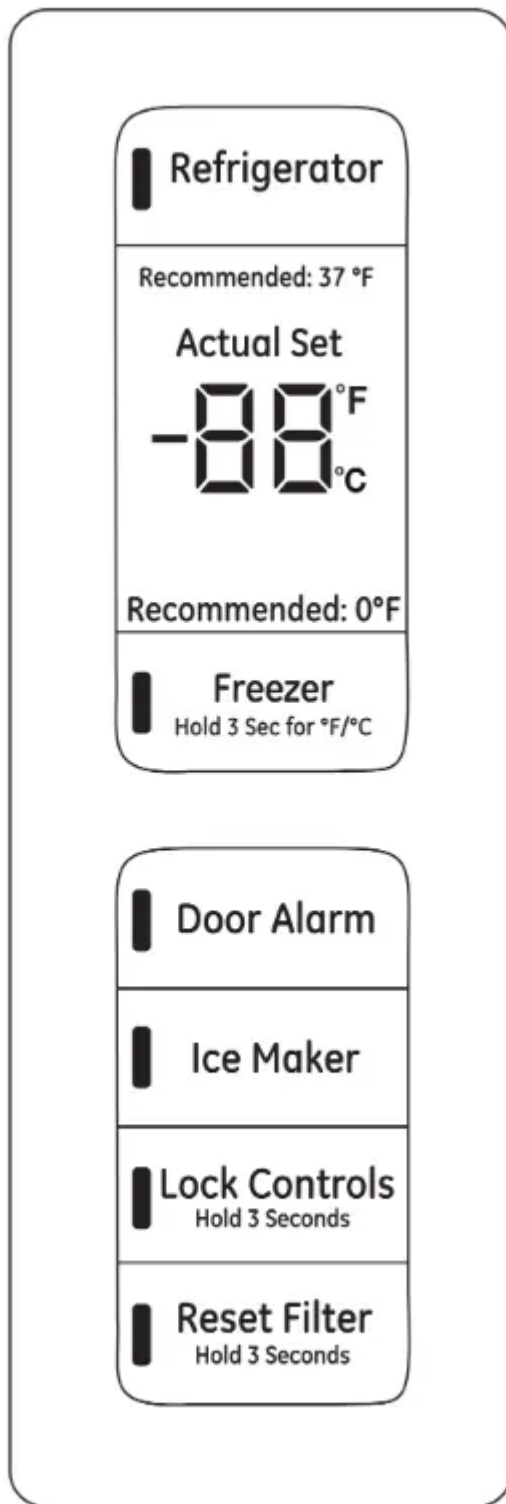

The temperature controls are preset in the factory at 37°F for the refrigerator compartment and 0°F for the freezer compartment. Allow 24 hours for the temperature to stabilize to the preset recommended settings.

**Control Style D:** The temperature controls can display both the SET temperature as well as the actual temperature in the refrigerator and freezer. The actual temperature may vary slightly from the SET temperature based on usage and operating environment (PWE23 and GNE29 only).



## Changing the Temperature for Control Style A

### To Change the Refrigerator Temperature:

Press the **Fridge** button and current set temperature will display. Pressing and releasing the button will cycle through the available temperature settings. Press and hold button for **Turbo Cool** feature. The display will show **tC**.

### To Change the Freezer Temperature:

Press the **Freezer** button and current set temperature will display. Pressing and releasing the button will cycle through the available temperature settings. Press and hold button for **Turbo Freeze** feature. The display will show **tF**.

Cooling system can be turned off by pressing and holding **Freezer** and **Start Heating**. **OFF** will be displayed. To turn on, press **Fridge** or **Freezer**. **ON** will be displayed.

Turning the cooling system off stops the cooling to the refrigerator, but it does not shut off the electrical power.

## Changing the Temperature for Control Styles B and C

To change the temperature, press and release the Freezer or Fridge pad. The display will show the set temperature. To change the temperature, press either the *Freezer* or *Fridge* pad until the desired temperature is displayed. Press and hold button for Turbo Cool feature. The display will show tC. Press and hold button for Turbo Freeze feature. The display will show tF.

To turn off the cooling system press and hold the **Fridge** and **Ice Maker** buttons. To turn on, press **Fridge** or **Freezer**.

Turning the cooling system off stops the cooling to the refrigerator, but it does not shut off the electrical power.

## Changing Temp. for Control Style D

Temperature Display is located on inside of left-hand refrigerator door. **To change the temperature**, press and release the **REFRIGERATOR** or **FREEZER** pad. The **ACTUAL TEMP** light will come on and the display will show the actual temperature. To change the temperature, tap either the **REFRIGERATOR** or **FREEZER** pad until the desired temperature is displayed.

To turn **OFF** cooling system, press and hold the **REFRIGERATOR** and **FREEZER** pads simultaneously for 3 seconds. When cooling system is **OFF** the display should read **OF**. To turn **ON** cooling system, press either **REFRIGERATOR** or **FREEZER** pad. The display will show the preset temperature settings of **37°F (3°C)** for refrigerator and **0°F (-18°C)** for freezer.

Turning the cooling system off stops the cooling to refrigerator, but it does not shut off the electrical power

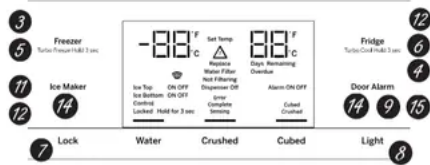
**Control Style A, External Controls PFE28P, PYE22P****Control Style B, External Controls PFH28, PFE28K, DFE28, PFD28, PYE22K, PYD22, DYE22****Control Style C, External Controls GFD28, GFE28, GFE26, GFS26, GYE22, GYS22****1 Hands-free Autofill\***

Hands-free Autofill uses sensors to monitor container height to automatically dispense filtered water without having to activate the paddle.

**2 Start Heating\***

The Start Heating button is used to initiate the water heating for the Single Serve feature. To abort the Start Heating feature, press and hold the Start Heat button for 3 seconds.

**3 Freezer temp control**

Adjust freezer compartment temperature.

**4 Fresh food temp control**

Adjust fresh food compartment temperature.

**5 TurboFreeze™ setting**

Activate TurboFreeze to quickly restore freezer temperatures after frequent door openings.

**6 TurboCool™ setting**

Activate TurboCool to quickly restore fresh food temperature after frequent door openings.

**7 Lock Controls**

Control Style A - Press and hold the Door Alarm pad for 3 seconds to lock out ice and water dispenser and all feature and temperature buttons.

Control Styles B & C - Press Lock pad and hold 3 seconds to lock out ice and water dispenser and all feature and temperature buttons,

**8 Dispenser light**

Lighting that can be turned on/off to light your dispenser.

**9 Door Alarm**

Sounds to alert when the freezer or fresh food doors have been left open. Press and hold Door Alarm pad and it will toggle the sound between low, high, and off.

**10 Brew Size\***

The Brew Size button is used to select the desired cup size for single serve. Press and hold the button for 3 seconds to toggle the brew type between Coffee and Cocoa

### **11 Ice maker setting**

Turn your ice makers on/off.

### **12 Cooling system On/Off**

Control Style A - Press and hold Freezer and Start Heating simultaneously to turn cooling system off. To turn cooling system on press either the Fridge or Freezer.

Control Style B & C - Press and hold Fridge and Ice Maker simultaneously for 3 seconds to turn the cooling system off. To turn cooling system on press either the Fridge or Freezer.

### **13 Brew Dispense**

Press and hold Brew Dispense button for 3 seconds, but no longer than 6 seconds, to dispense coffee or cocoa.

### **14 F°/C°**

Control Style A - Press and hold Freezer and Brew Size to switch between F°/C°

Control Style B & C - Press and hold Ice Maker and Door Alarm simultaneously for 3 seconds to switch between F°/C°

### **15 Sound Control for pad chimes**

Control Style A - Press and hold the Light pad: Once for High to Off, twice for Off to Low and three times for Low to High.

Control Styles B & C - Press and hold the Door Alarm pad: Once for High to Off, twice for Off to Low and three times for Low to High

### **16 High Altitude**

Control Style A (PYE and PFE only) - Press and hold Fridge and Door Alarm for to toggle between Hi AL and Lo AL for high altitude and low altitude.

### **Additional settings:**

- Connected Home ready\* (PFE28P, PYE22P, PFH only)
- Water Filter\* - An indicator will illuminate when the filter needs to be replaced. When a new filter is installed the indicator will go off.

### **Additional Mode:**

#### **• Sabbath Mode**

Control Style A - Press and hold Alarm and Light

simultaneously for 3 seconds to enter/exit Sabbath mode. Control Style B & C - Press and hold Lock and Light simultaneously for 3 seconds to enter/exit Sabbath mode. Sabbath Mode will turn

off or dim interior lights, temperature control and advanced features. Compressor will run on a timed defrost when in Sabbath mode.

## Controls Style D, Internal Controls GNE29, PWE23

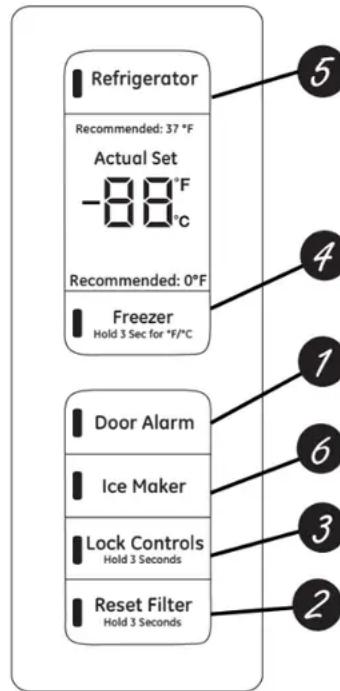

### 1 Door Alarm

Sounds to alert when the freezer or fresh food doors have been left open,

### 2 Reset Filter

Hold for 3 seconds after replacing filter.

### 3 Lock Controls

Press and hold 3 seconds to lock out ice and water dispenser and all feature and temperature buttons.

### 4 Freezer temp control

Adjust freezer compartment temperature

### 5 Refrigerator temp control

Adjust fresh food compartment temperature

### 6 Ice maker setting

Turn your ice maker on/off.

### Additional Mode:

## Sabbath Mode

Press and hold Door Alarm and Ice Maker simultaneously for 3 seconds to enter/exit Sabbath mode.

## Dispenser\*

### To reinstall Dispenser Tray (Type C Only)

Line up the guide on tray bottom with track on dispenser and slide it in until it stops against the back of the dispenser

### Important Facts About Your Dispenser

- Do not add ice from trays or bags to the door ice maker bucket. It may not crush or dispense.
- Avoid overfilling glass with ice and use of narrow glasses. Backed-up ice can jam the chute or cause the door in the chute to freeze shut. If ice is blocking the chute remove the ice bucket, poke it through with a wooden spoon.
- Beverages and foods should not be quick-chilled in the door ice maker bin. Cans, bottles or food packages in the storage drawer may cause the ice maker or auger to jam.
- To keep dispensed ice from missing the glass, put the glass close to, but not touching, the dispenser opening.
- Some crushed ice may be dispensed even though you selected **CUBED ICE**. This happens occasionally when a few cubes accidentally get directed to the crusher.
- After crushed ice is dispensed, some water may drip from the chute.
- Sometimes a small mound of snow will form on the door in the ice chute. This condition is normal and usually occurs when you have dispensed crushed ice repeatedly. The snow will eventually evaporate.

### To Use the Internal Water Dispenser\*

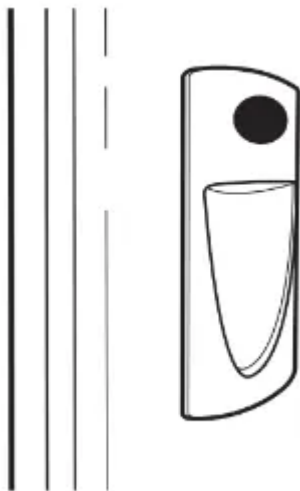

The water dispenser is located on the left wall inside the refrigerator compartment.

**To dispense water:**

1. Hold the glass against the recess.
2. Push the water dispenser button.
3. Hold the glass underneath the dispenser for 2-3 seconds after releasing the dispenser button.

Water may continue to dispense after the button is released.

If no water is dispensed when the refrigerator is first installed, there may be air in the water line system. Press the dispenser button for at least 5 minutes to remove trapped air from the water line and to fill the water system. During this process, the dispenser noise may be loud as the air is purged from the water line system. To flush out impurities in the water line, throw away the first 6 glassfuls of water.

**NOTE:** To avoid water deposits, the dispenser should be cleaned periodically by wiping with a clean cloth or sponge.

**AUTOFILL\***

**To Use HANDS FREE AUTOFILL:**

- Center container on Recess Dispenser Tray as far back as possible without activating paddle and remove hand from container
- Press **AUTOFILL**

**To Stop AUTOFILL**

- Press **AUTOFILL** to stop.

**Important Facts about AUTOFILL**

- For optimum results, use a uniform container between 4-8" (10-20 cm) tall and 2-6" (5-15 cm) wide.
- Fill level and functionality may vary on containers taller than 8" (20 cm) or wider than 6" (15 cm).
- Container volumes may vary, if error message "Not Found" is given, try a different container.
- AUTOFILL will time out.
  - Handles, straws, and garnishes on the rim of the container may cause overflowing or variation in fill volumes.
  - Splashing may occur depending on the location of the container, water flow rate, container shape, and ice cubes.
  - Keep sensors clean with a clean damp cloth, and do not spray liquid or cleaners directly on sensors



- AUTOFILL works best with household water pressure of 60 to 100 psi (414 to 689 kPa).
- Ice in container may affect fill volume. If issues are experienced, use less ice.

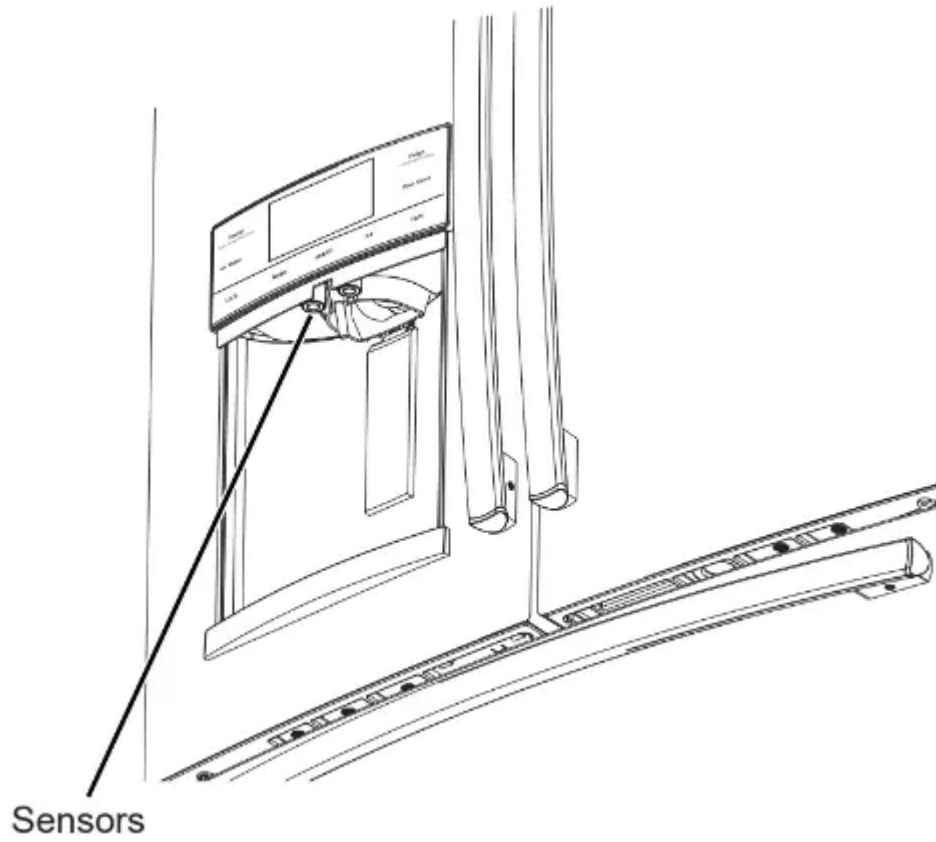

## CARE AND CLEANING

### Cleaning the Outside

#### Directions for Cleaning Outside Surfaces, Door Handles, and Trim

DO USE	DO NOT USE
Soft, clean cloth or sponge	Abrasive cloths, scrubbing sponges, scouring or steel wool pads
<p>Mild detergent mixed with warm water Approved stainless steel cleaners; Visit the GE Appliances parts store for approved stainless steel cleaners: <b>GEAppliancesparts.com</b> or call <b>877.959.8688</b></p> <p>Cleaners with oxalic acid such as Bar Keepers Friend Soft Cleanser™ can be used to remove surface rust, tarnish and small blemishes on stainless steel surfaces only</p>	<p>Abrasive powders or sprays Window Sprays or Ammonia Citrus or plant oil-based cleaners Acidic or vinegar-based cleaners Oven cleaners Cleaners containing acetone (propanone) Any cleaner with WARNING about plastic contact</p>

## Cleaning the Inside

**To help prevent odors**, leave an open box of baking soda in the refrigerator and freezer compartments.

### **Unplug the refrigerator before cleaning.**

If this is not practical, wring excess moisture out of sponge or cloth when cleaning around switches, lights or controls.

Use an appliance wax polish on the inside surface between the doors.

Use warm water and baking soda solution—about a tablespoon (15 ml) of baking soda to a quart (1 liter) of water. This both cleans and neutralizes odors. Rinse and wipe dry.

### **To clean the inside metal panel\***, open the outer door

using the Door in Door Latch. Clean the panel with a mild detergent and then wipe dry with a soft cloth. Do not use any stainless steel cleaner on the panel as it may damage the surrounding plastic.

## Behind the Refrigerator

Be careful when moving the refrigerator away from the wall. All types of floor coverings can be damaged, particularly cushioned coverings and those with embossed surfaces.

Raise the leveling legs located at the bottom front of the refrigerator.

Pull the refrigerator straight out and return it to position by pushing it straight in. Moving the refrigerator in a side direction may result in damage to the floor covering or refrigerator.

Lower the leveling legs until they touch the floor

## **Preparing for Vacation**

For long vacations or absences, remove food and unplug the refrigerator. Clean the interior with a baking soda solution of one tablespoon (15 ml) of baking soda to one quart (1 liter) of water. Leave the doors open.

If the temperature can drop below freezing, have a qualified service technician drain the water supply system to prevent serious property damage due to flooding.

1. Turn refrigerator off or unplug the refrigerator.
2. Empty ice bucket
3. Turn water supply off

**If you cut the water supply off, turn off the ice maker.**

Upon returning from vacation:

1. Replace the water filter.
2. Run 2 gallons (7.57 liters) of water through the cold water dispenser (about 5 minutes) to flush the system.

## **Preparing to Move**

Secure all loose items such as shelves and drawers by taping them securely in place to prevent damage.

When using a hand truck to move the refrigerator, do not rest the front or back of the refrigerator against the hand truck. This could damage the refrigerator.

Handle only from the sides of the refrigerator.

Be sure the refrigerator stays in an upright position during moving.

## **Replacing the Lights**

### **Refrigerator Lights (LEDs)**

Appearance may vary by model.

There is LED lighting in fresh food compartment and on the bottom of the fresh food doors to light the freezer compartment.\*

An authorized technician will need to replace the LED light.

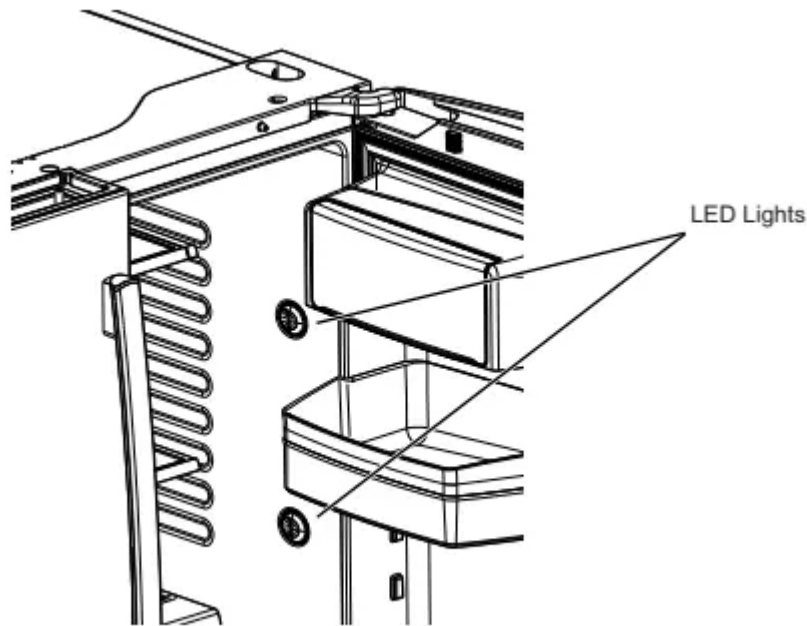

## TROUBLESHOOTING TIPS

### Normal Operating Conditions.

Do you hear what I hear? These conditions are normal.

**HUMMM...**  
**WHOOSH...**

- The new high efficiency compressor may run faster and longer than your old refrigerator and you may hear a high-pitched hum or pulsating sound while it is operating.
- You may hear a whooshing sound when the doors close. This is due to pressure equalizing within the refrigerator.
- After dispensing ice, a motor will close the ice chute to keep warm room air from entering the ice bucket, maintaining ice at a freezing temperature.

The hum of the motor closing the ice chute is normal, shortly after dispensing ice.

**CLICKS, POPS,**  
**CRACKS and SNAPS**

- You may hear cracking or popping sounds when the refrigerator is first plugged in. This happens as the refrigerator cools to the correct temperature.
- The compressor may cause a clicking or chirping sound when attempting to restart (this could take up to 5 minutes).

- Expansion and contraction of cooling coils during and after defrost can cause a cracking or popping sound.
- On models with an ice maker, after an ice making cycle, you may hear the ice cubes dropping into the ice bucket.
- After dispensing ice, a motor will close the ice chute to keep warm room air from entering the ice bucket, maintaining ice at a freezing temperature.

### **START UP COOLING**

It can take up to 24 hours for the refrigerator and freezer temperatures to match the display. During that time refrigerator and freezer door openings should be minimized.

### **TIPS**

- Freezer cools first.
- Refrigerator compartment cools last; it may take several hours after the freezer.
- Turning off ice maker makes both fresh food and freezer food cool faster.



- You may hear the fans spinning at high speeds. This happens when the refrigerator is first plugged in, when the doors are opened frequently or when a large amount of food is added to the refrigerator or freezer compartments. The fans are helping to maintain the correct temperatures.
- The fans change speeds in order to provide optimal cooling and energy savings.

### **WATER SOUNDS**



- The flow of refrigerant through the cooling coils may make a gurgling noise like boiling water.
- Water dropping on the defrost heater can cause a sizzling, popping or buzzing sound during the defrost cycle.
- A water dripping noise may occur during the defrost cycle as ice melts from the evaporator and flows into the drain pan.
- Closing the door may cause a gurgling sound due to pressure equalization.

## Before you call for service



Problem	Possible Causes	What to Do
Water filter indicated as installed incorrectly or a leak is present on cap control panel.	Water filter installed backward or is leaking.	Check for leak. If no leak is present, remove filter/ bypass plug**, rotate 180° and reinstall.
“Warning Triangle” is lit Replace Filter/Replace Water Filter is lit Over Due light is lit	Water filter leaking or needs replacing Water filter backwards	Replace water filter, check for leak Remove filter, rotate 180° and reinstall
Dispenser Off is lit	Control A, B & C Wrong filter installed	Replace filter with proper filter Remove filter, rotate 180° and reinstall
Not filtering	Filter bypass installed Controls B & C	Install correct waterfilter
Reset Filter is lit	Water filter leaking or needs replacing	Replace water filter, or install filter bypass **  Press and hold Reset Filter for 3 seconds to reset (Control D only)
Water filter indicator light is not lit	This is normal. This indicator will turn on to tell you that you need to replace the filter soon.	See <i>About the Water Filter</i> for more information.
Handle is loose/handle has a gap.	Handle needs adjusting	See <i>Attach Fresh Food Handle</i> and <i>Attach the Freezer Handle</i> sections for detailed instructions.
Refrigerator beeping	This is door alarm	-Turn off or disable with door closed



		-If door open and alarm is sounding, you can only snooze the alarm
Not cooling	The cooling system is off	See <i>About Controls</i> .
Water has poor taste/odor*	Water dispenser has not been used for a long time	Dispense water, until all water in system is replenished.
Water in glass is warm*	Normal when refrigerator is first installed	Wait 24 hours for the refrigerator to completely cool down
	Water dispenser has not been used for a long time	Dispense water, until all water in system is replenished
	Water system has drained	Allow several hours for replenished supply to chill
Water dispenser does not work*	Water supply line turned off or not connected	See <i>Installing the Water Line</i>
	Water filter clogged or filter/bypass plug not installed	Replace filter cartridge or remove filter and install bypass plug**
	Air may be trapped in the water system	Press the dispenser arm for at least 5 minutes.
	Water in reservoir is frozen because the controls are set too cold	Set the refrigerator control to a warmer setting and wait 24 hours. If the water does not dispense after 24 hours, call for service

Water spurting from dispenser*	Newly installed filter cartridge	Run water from the dispenser for 5 minutes (about 2 gallons)
No water or ice cube production*	Supply line or shutoff valve is clogged	Call a plumber
	Water filter is clogged	Replace filter cartridge or remove filter and install bypass plug**
	Filter cartridge not properly installed	Remove and reinstall filter cartridge, being certain that it locks in place.
	Ice maker is turned off	Check that the ice maker is turned on. See <b><i>About the Automatic Ice Maker.</i></b>
Water is leaking from dispenser*	Air may be present in the water line system, causing water to drip after being dispensed	Dispense water for at least 5 minutes to remove air from system
<b>AUTO FILL</b> under fill/no fill*	Not all containers work with <b>AUTO FILL</b>	Try different container
	Error message	See page 14 Clean sensor. See page 14.
<b>AUTO FILL</b> overfills*	Not all containers work with <b>AUTO FILL</b>	Try different container



Freezer cooling, fresh food not cooling	Normal, when refrigerator first plugged in or after extended power outage	Wait 24 hours for temperature in both compartments to reach selected temperatures.
Ice dispenser opens after closing freezer drawer *	Normal	The ice dispenser door may open after closing freezer door to allow access
Low brewing flow rate	There may have been a dent at the bottom of K-Cup causing the pin to pierce the filter allowing coffee grounds clogging the bottom pin	Avoid using damaged/dented K-cups, and clean the lower needle before next brew
Low brewing flow rate / water drips from inner door	Top needle of the brewer clogged	Unclog the top needle holes using a paper clip and rinse brewer. Rinse brewer after every use.
Brewer is not detected or hot water leaking from top of the brewer	Incorrect assembly of brewer in the bracket	Make sure the Keurig Logo is in the front. Push brewer all the way in the brackets
Coffee dispensed with splash or bubble bursting	Blocked vent hole in the brewer	Make sure the vent hole at the bottom of the brewer is clear from food or any other contamination
Beverage quality not as expected	You may be using non-standard or out dated K-Cups	Recommend using official Keurig K-cups that are not past expiration and have not been damaged
Liquid drips from the brewer after brewer cycle is	It is possible for liquids to be retained by the	Use a cloth or container to capture the drips when brewer is removed

completed and the brewer is removed from the bracket	brewer and drip when it is removed	
Delay when using Keurig K-cup Pod dispenser	To ensure a quality beverage is delivered, a short delay is required to ensure the refrigerator is operating correctly	Ensuring consistent, quality operation requires the refrigerator to delay dispense for a short period of time
After brewing, my powdered beverage is not fully cleared from the used pod	Depending on size selected, the powder may not dissolve fully.  Some powdered beverages develop into 'clumps' when left sitting for some time	Shake the powdered pods before brewing to break up these clumps and allow better clearing. For powdered beverage with no filter, use the Cocoa cycle selection
Brewer lid is difficult to close	K-cup is not fully seated	Press K-cup all the way down into the brewer prior to closing the lid. Lower needle must puncture K-cup before closing the brewer lid
Brewer leaks during the brew cycle	Trouble in closing brewer lid or damaged K-cup	Press K-cup all the way down into the brewer prior to closing the lid. Lower needle must puncture K-cup before closing the brewer lid. Recommend using official Keurig K-cups that have not been damaged and have a good seal between the top cover and plastic bottom

## Truth or Myth



Truth or Myth?	Answer	Explanation
The refrigerator water filter may require replacement prior to six months	TRUE	The water filter indicator will indicate the need to replace the water filter every six months or 170 gallons of water dispensed (select models only). Water quality varies from city to city. If water flow from the dispenser slows, or ice production decreases, the water filter should be replaced, even though the filter indicator may not indicate the need for replacement
The automatic ice maker in my refrigerator will produce ice when the refrigerator is plugged into a power receptacle.	MYTH	The refrigerator must be connected to water, and the ice maker must be turned on. Make sure the ice maker is turned on, only after the water line is connected and water is turned on. The ice maker can be turned <i>on/off</i> from the controls and ensure the ice maker is on, as indicated on the refrigerator control panel. See <i>About the Automatic Ice Maker</i> .
After the refrigerator has been plugged in and connected to water, I will immediately have unlimited chilled water available from the water dispenser.	MYTH	The water dispenser tank located inside the refrigerator stores water for dispensing. The water in this tank requires 24 hours to chill after installation. High usage conditions will not allow time for the water to chill.
After water dispenses, a few drops of water are normal.	TRUE	A few drops of water may fall from the dispenser, after the dispenser paddle has been released. To minimize the drops, remove the glass slowly from the dispenser.
	MYTH	



<p>I will never see frost inside the freezer compartment.</p>		<p>Frost inside the freezer typically indicates that the door is not properly sealed, or has been left open. If frost is found, clear the frost using a plastic spatula and towel, then check to ensure that no food packages or containers are preventing the freezer door from closing. Check the refrigerator control panel to ensure the door alarm is on.</p>
<p>When the refrigerator is installed, or after replacing the water filter, 1 must dispense water for five minutes.</p>	<p>TRUE</p>	<p>A newly installed refrigerator or water filter contains air in the water lines. Press the dispenser paddle and dispense cold water for at least 5 minutes to remove air from the water line, and flush the filter.</p>
<p>To fill the ice bucket to the maximum capacity, 1 should dispense 12 and 18 hours after installation.</p>	<p>TRUE</p>	<p>Dispensing 3-4 cubes 12 hours and 18 hours after installation, allows ice to disperse within the ice bucket, which in turns calls on the ice maker to produce additional ice. Normal ice production = 100 cubes in 24 hours.</p>
<p>I can use the water filter bypass plug to determine if the filter requires replacement.</p>	<p>TRUE</p>	<p>Decrease in flow from the water dispenser, or decreased ice production, may indicate the need to replace the water filter. Install the water filter bypass plug (provided with the refrigerator on some models*), and check flow from the dispenser. If water flow returns to normal with the bypass plug in place, replace the water filter.</p>
<p>The top of the refrigerator doors will always be aligned</p>	<p>MYTH</p>	<p>Several things can affect the fresh food door alignment, including the floor the refrigerator is installed on and loading of doors. If the top of the fresh food doors are not aligned, use a 1/4"</p>



		alien wrench to adjust the right/left hand door. The adjustment screw is located on the bottom right or left hand side of the door; open the freezer door to access the screw.
Refrigerator door handles can be easily tightened.	TRUE	If door handles are loose or have a gap, the handle can be adjusted using a 1/8" alien wrench, on set screws located on the ends of the handles.
There may be odor and taste problems with your ice	TRUE	After starting the ice maker, throw away 24 hours of ice production to avoid odor and taste problems.
I can make fine adjustments to the fresh food doors to align them.	TRUE	If the fresh food doors are not aligned, use a 1/4" Allen wrench to adjust the right hand door. The adjustment screw is located on the bottom of the right/left hand door. Open the freezer door to access.
Door handles should always be removed for installation.	MYTH	If the doors must be removed do not remove the handles, or if the refrigerator will fit easily through the passage way opening. Adjust handles that are loose or have a gap, by adjusting 1/8" set screws on either end of handles.
Door removal is always required for installation	MYTH	Check chart on reverse side of this instruction. Doors should only be removed when necessary to prevent damage from passage way or access to final location.
Refrigerator doors that won't close after installation, can be	TRUE	Door mechanism works best if installed at 90°+. If installed at 180°, remove the door from the mid hinge, and swing the door 180° before

adjusted to close properly.		reinstalling. See <i>Reinstalling the Refrigerator Doors</i> .
There is an adjustment to rear wheels.	MYTH	Front leveling legs are adjustable and should be used to balance the refrigerator. Leveling legs are used to make initial fresh food door adjustment.
Check for leaks after all water connections are made.	TRUE	While purging the air from the water system, check all water line connections for leaks. Check the connection to the household water supply at back of refrigerator, and door water line connect.
Any packaging residue can be cleaned off the refrigerator using any cleaner.	MYTH	Do not use wax, polish, bleach, or other products containing chlorine on Stainless Steel panels, door handles and trim. Check this instruction under "Cleaning the Outside" for full details.

### Warning

This content is compiled from multiple sources and is provided for reference purposes only. It may not be complete or fully applicable to all situations. If you are unable to resolve your issue, please contact the product manufacturer or an authorized service provider for official support.