

## PRODUCT OVERVIEW

The images in this guide may be different from the actual components and accessories, which are subject to change by the manufacturer without prior notice for product improvement purposes.

### Exterior

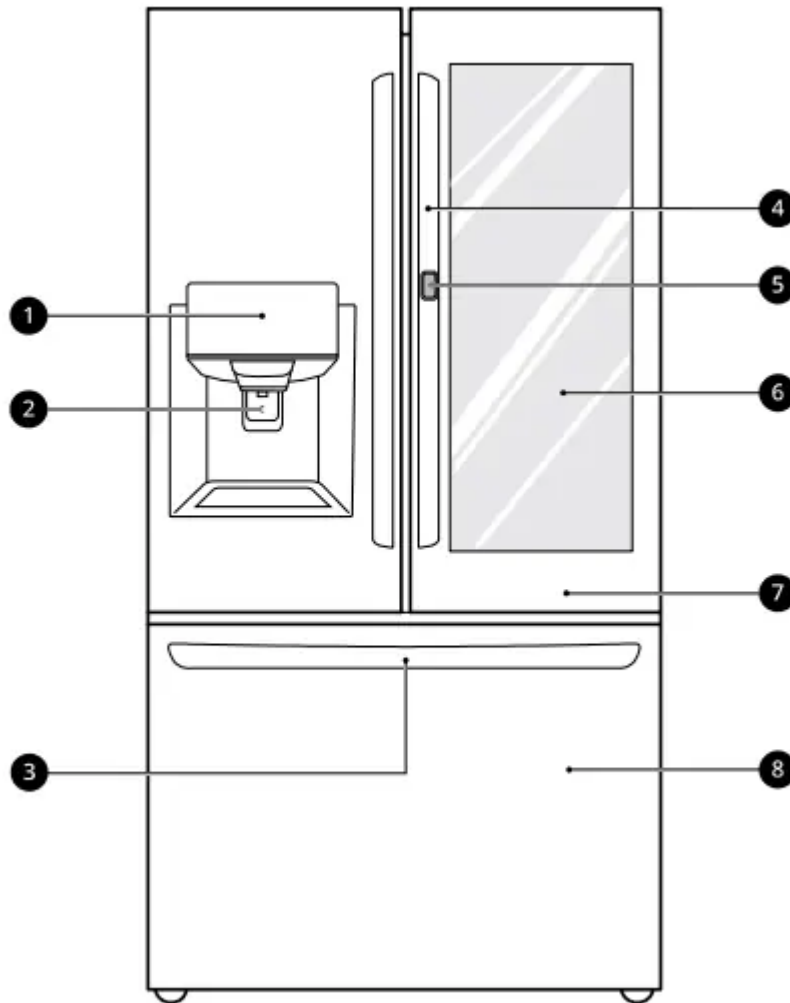

**1. Control Panel**

Sets the refrigerator temperature and freezer temperature, the water filter condition and the dispenser mode.

**2. Filtered Water and Ice Dispenser**

Dispenses purified water and ice.

**3. SmartPull Handle**

Easily opens the freezer door.

**4. Handle**

Opens and closes the refrigerator door.

## 5. Door Button

Opens the Door-in-Door Compartment.

## 6. InstaView Door-in-Door

The InstaView Door-in-Door compartment allows for easy access to commonly used food items.

## 7. Refrigerator

Fresh food compartment

## 8. Freezer

Frozen food compartment

## Interior

### Door-in-Door:

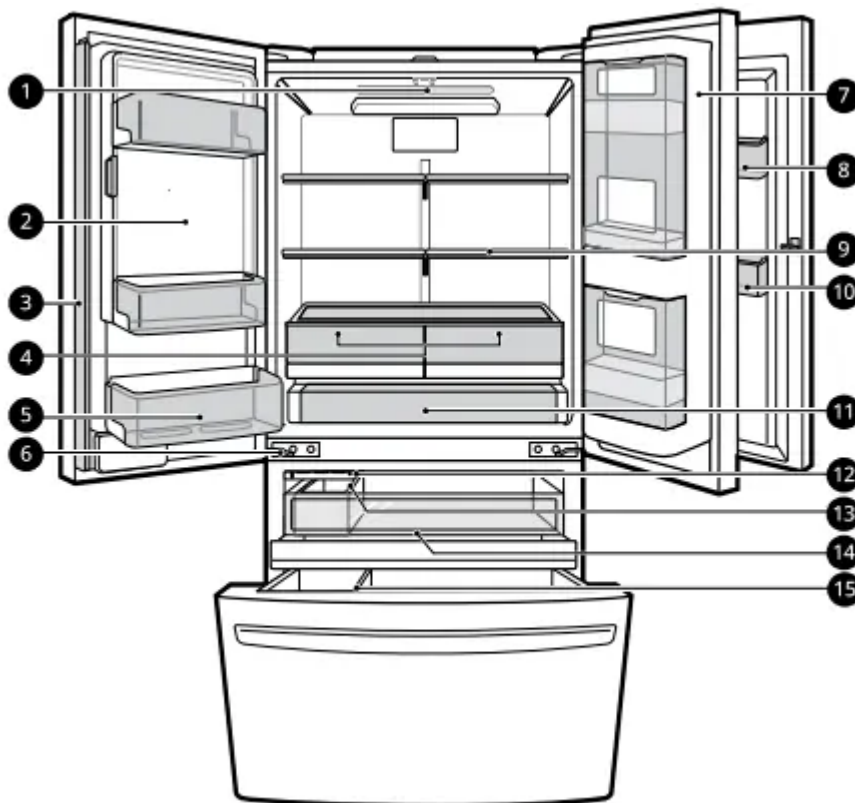

### 1. LED Interior Lighting

Light up the inside of the refrigerator.

### 2. In-Door Icemaker (Refrigerator)

This is where ice is automatically produced and stored.

### 3. Door Mullion

Prevents the cold air in the refrigerator from escaping when the doors are closed.

### CAUTION :

To reduce the risk of scratching the door or breaking the center door mullion, make sure

that the folding door mullion is folded in before closing the left-hand door.

The door alarm will sound every 30 seconds if the door remains open longer than one minute.

**4. Humidity Controlled Crisper**

Helps vegetables and fruit to stay crisp and controls humidity.

**5. Fixed Door Bin**

Store chilled food or drinks.

**6. Auto-Closing Hinge**

The refrigerator doors and freezer drawers close automatically when pushed slightly. (The door only closes automatically when it is open at an angle of less than 30°.)

**7. Door-in-Door Case**

A convenient storage area for frequently-used items that require easy access.

**8. Cheese & Butter and Condiment Bins**

Cheese & Butter and Condiment bins are specially designed for these items, making spreading butter and slicing cheese easier.

**9. Adjustable Refrigerator Shelf**

The refrigerator shelves are adjustable to meet individual storage needs.

**10. Modular Door Bin**

Interchangeable bins can be arranged to suit storage needs.

**11. Glide'N'Serve**

Store food items at a different temperature than the regular refrigerator area.

**12. Automatic Icemaker (Freezer)**

Dispenses ice automatically.

**13. Ice Bin**

The ice is automatically produced by the icemaker in the freezer and stored in an ice bin in the freezer.

**14. Pullout Drawer**

Provides extra storage within the freezer compartment.

**15. Durabase and Durabase Divider**

Provides storage for large food items.

## OPERATION

### Before Use

#### Checklist

**Clean the refrigerator.**



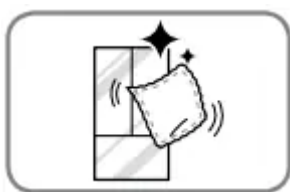

Clean the refrigerator thoroughly and wipe off all dust that accumulated during shipping.

**CAUTION**

- Do not scratch the refrigerator with a sharp object or use a detergent that contains alcohol, a flammable liquid or an abrasive when removing any tape or adhesive from the refrigerator. Remove adhesive residue by wiping it off with your thumb or dish detergent.
- Do not peel off the model or serial number label or the technical information on the rear surface of the refrigerator.

**Open refrigerator doors and freezer drawers to ventilate the interior.**

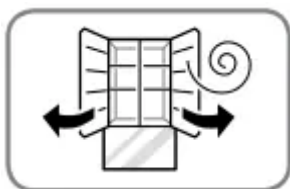

The inside of the refrigerator may smell like plastic at first. Remove any adhesive tape from inside the refrigerator and open the refrigerator doors and the freezer drawers for ventilation.

**Connect the power supply.**

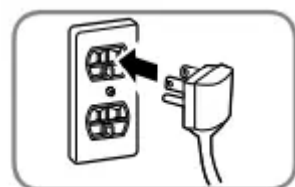

Check if the power supply is connected before use.

**Turn off the icemaker.**



Turn off the icemaker if the refrigerator is not yet connected to the water supply.

**NOTE:** The icemaker water valve may buzz if the icemaker is turned on while the refrigerator is not connected to the water supply.

**Wait for the refrigerator to cool.**



Allow the refrigerator to run for at least two to three hours before putting food in it. Check the flow of cold air in the freezer compartment to ensure proper cooling.

**CAUTION:** Putting food in the refrigerator before it has cooled could cause the food to spoil, or a bad odor to remain inside the refrigerator.

**The refrigerator makes a loud noise after initial operation.**

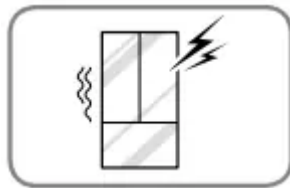

This is normal. The volume will decrease as the temperature decreases.

## Control Panel

### Control Panel Features

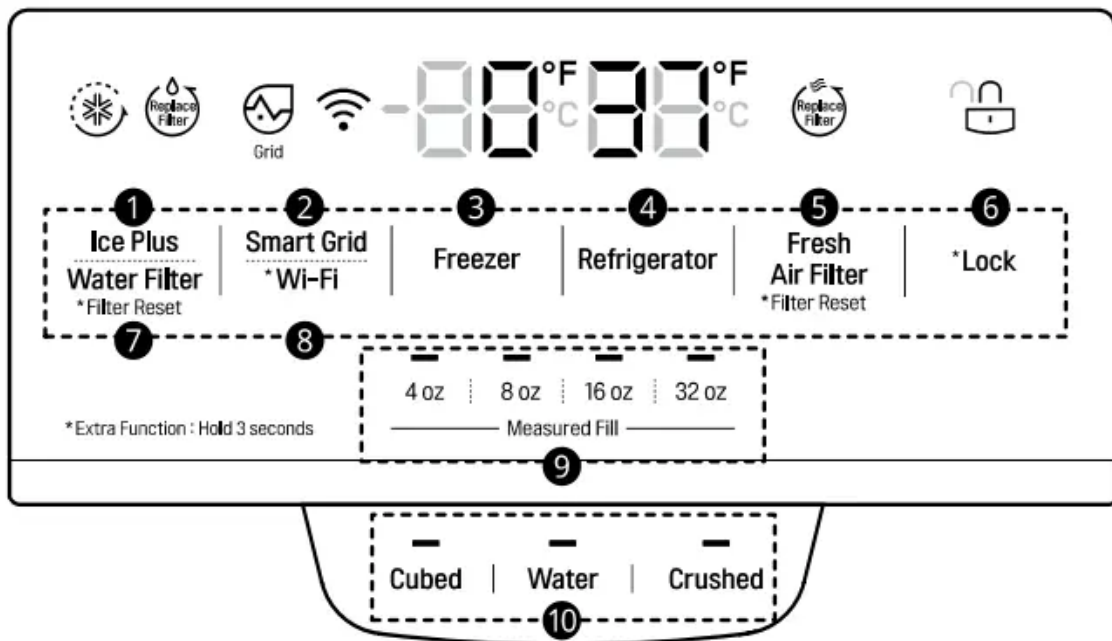

#### 1. Ice Plus

This function increases both ice making and freezing capabilities.

Press the Ice Plus button to illuminate the icon and activate the function for 24 hours. The function automatically shuts off after 24 hours. Stop the function manually by pressing the button once more.

## 2. Smart Grid

Press the Smart Grid button to turn the function On/Off. When the function is on, the icon illuminates. The function automatically turns on when the refrigerator is connected to the Wi-Fi network.

When the refrigerator is responding to a Demand Response (DR) message from the electric company, the Grid text illuminates.

## 3. Freezer

Indicates the set temperature of the freezer compartment in Celsius (°C) or Fahrenheit (°F). The default freezer temperature is 0°F (-18 °C). Press the Freezer button repeatedly to select a new set temperature from - 7 °F to 5 °F (-23 °C to -15 °C).

## 4. Refrigerator

Indicates the set temperature of the refrigerator compartment in Celsius (°C) or Fahrenheit (°F). The default refrigerator temperature is 37 °F (3 °C). Press the Refrigerator button repeatedly to select a new set temperature from 33 °F to 43 °F (1 °C to 7 °C).

### NOTE

- To change the temperature mode from °F to °C (or vice versa) press and hold the Refrigerator and Freezer buttons simultaneously for approximately five seconds. The temperature indicator on the display window switches between Celsius and Fahrenheit.
- The displayed temperature is the target temperature, and not the actual temperature of the refrigerator. The actual refrigerator temperature depends on the food inside the refrigerator.

## 5. Fresh Air Filter

The Fresh Air Filter helps remove odors from the refrigerator.

**NOTE:** Replace the air filter when the  icon turns on. After replacing the air filter, press and hold the Fresh Air Filter button for three seconds to turn the icon light off. Replace the air filter approximately every six months.

## 6. Lock

The lock function disables every other button on the display.

- When power is initially connected to the refrigerator, the lock function is off.
- To lock the control panel buttons, press and hold the Lock button until the  icon appears in the display and the function is activated.

- To disable the function, press and hold the Lock button for approximately three seconds.

## 7. Water Filter



Replace the water filter when the  icon turns on. After replacing the water filter, press and hold the Water Filter button for three seconds to turn the icon light off. Replace the water filter approximately every six months.

## 8. Wi-Fi

The Wi-Fi button, when used with the LG ThinQ app, allows the refrigerator to connect to a home Wi-Fi network. Refer to Smart Functions for information on the initial setup of the application.

The  icon shows the status of the refrigerator's network connection. The icon illuminates when the refrigerator is connected to the Wi-Fi network.

Press and hold the Wi-Fi button for 3 seconds to connect to the network. The icon blinks while the connection is being made, then turns on once the connection is successfully made.

## 9. Measured Fill

The measured fill function dispenses premeasured amounts of water automatically.

## 10. Water & Ice Type

Select the desired dispenser mode from the buttons on the dispenser control panel. Press the dispenser switch with a glass or other container to dispense cubed ice, water or crushed ice.

### Changing the Craft Ice Mode

#### NOTE:

- This feature is only available on some models.
- The Freezer button can also be used to set the Craft Ice mode to either 3 ICE or 6 ICE. The default mode is 3 ICE

1. Touch any button on the control panel to activate it.
2. Press and hold the Freezer button for 3 seconds until the control panel beeps and the current ice mode appears.

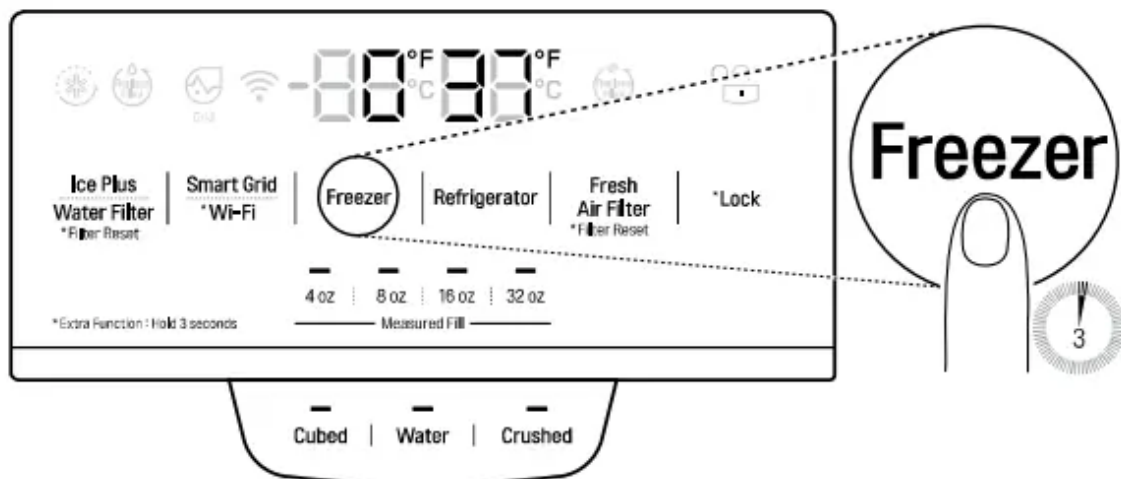

3. Press the Freezer button repeatedly to toggle between the 3 ICE and 6 ICE modes. After 5 seconds of idle time, the last mode set will be saved, and the display will return to normal.

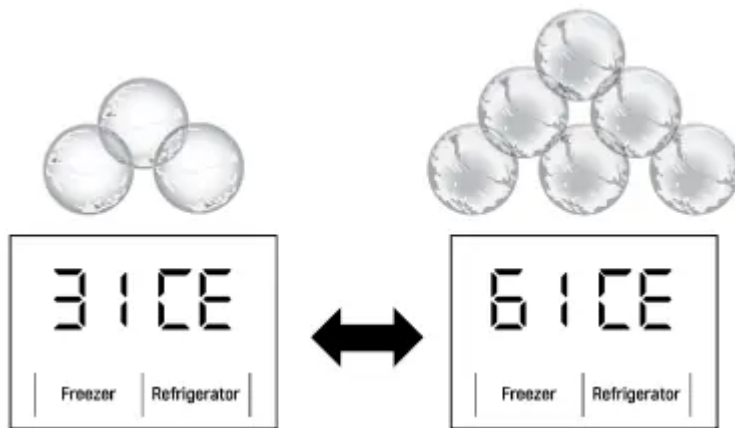

**NOTE:** For more ice, select the 6 ICE mode. For clearer ice, select the 3 ICE mode.

**NOTE:**

### Display Mode and InstaView Display Mode (For Store Use Only)

- The Display Mode disables all cooling in the refrigerator and freezer sections to conserve energy while on display in a retail store. When activated, OFF is displayed on the control panel and the display remains on for 20 seconds.
  - To deactivate/activate the Display Mode:  
Open either refrigerator door. Press the Ice Plus button 3 times while pressing and holding the Refrigerator button. The control panel beeps and the temperature settings display to confirm that Display Mode is deactivated. Use the same procedure to activate Display Mode.
- The InstaView Display Mode automatically turns the LED light inside the InstaView Door-in-Door on and off in cycles of 10 seconds ON and 2 minutes 50 seconds OFF.
  - To activate the InstaView Display Mode:  
Activate the Display Mode first. Then open all refrigerator and freezer doors and within 5 seconds knock 3 times on the door glass.

- To deactivate the InstaView Display Mode:

Open all refrigerator and freezer doors and within 5 seconds knock 3 times on the door glass. The refrigerator is now in Display Mode.

• To deactivate the Display Mode and InstaView Display Mode at once:

Open either refrigerator door. Press the Ice Plus button 3 times while pressing and holding the Refrigerator button.

**NOTE:** When the refrigerator is in the Power Saving Mode, the display remains off until a door is opened or a button is pressed. Once on, the display remains on for 20 seconds.

## **Sabbath Mode**

### **Using the Sabbath Mode**

Sabbath mode is used on the Jewish Sabbath and holidays.

- To turn Sabbath mode on, touch the display to activate it, then press and hold the Freezer and Wi-Fi buttons for 3 seconds until sb appears in the display.
- To turn Sabbath mode off manually, press and hold the Freezer and Wi-Fi buttons for 3 seconds.

#### **NOTE:**

- Sabbath mode automatically turns off after 96 hours.
- Once turned on, Sabbath mode is maintained even after a power outage.
- Selecting Sabbath mode automatically turns off the Alarm functions.
- The dispenser or InstaView is disabled in Sabbath Mode. This information is only available on models with the dispenser or InstaView.

## **Ice and Water Dispenser**

### **Before Using the Ice and Water Dispenser**

#### **CAUTION:**

- Keep children away from the dispenser. Children may play with or damage the controls.
- Throw away the first bin full of ice (about 140- 160 cubes) after installation. The first ice and water dispensed may include particles or odor from the water supply line or the water tank. This is also necessary if the refrigerator has not been used for a long time.
- Dispense and throw away 2.5 gallons of water (flush for approximately 5 minutes) after installation. Do not dispense the entire 2.5 gallon amount continuously. Press and release the dispenser pad for cycles of 30 seconds ON and 60 seconds OFF. This is also necessary if the refrigerator has not been used for a long time.

- If ice or water dispenses unexpectedly, turn off the water supply and contact an LG Electronics Customer Information Center.
- Never use a glass that is exceptionally narrow or deep. Ice may jam in the ice passage and refrigerator performance may be affected.
- When dispensing ice from the dispenser, do not use a fragile container.

**NOTE:**

- The dispenser will not operate when either of the refrigerator doors is open.
- If discolored ice is dispensed, check the water filter and water supply. If the problem continues, contact an LG Electronics Customer Information Center. Do not use the water or ice until the problem is corrected.
- Dispense ice into a glass before filling it with water or other beverages. Splashing may occur if ice is dispensed into a glass that already contains liquid.
- Some dripping may occur after dispensing. Hold the cup beneath the dispenser for a few seconds after dispensing to catch all of the drops.
- Keep containers at an appropriate distance from the dispensers. Tall, narrow glasses should be held far enough from the ice outlet to prevent ice from jamming in the ice chute. A container with a very small opening should be held as close to the dispenser as possible to avoid spilling.

**Using the Ice and Water Dispenser**

1. Press the button for the desired dispenser mode on the dispenser control panel. The LED lights up when the mode is selected.
2. Press the dispenser paddle (1) with a glass or other container to dispense cubed ice, water or crushed ice.

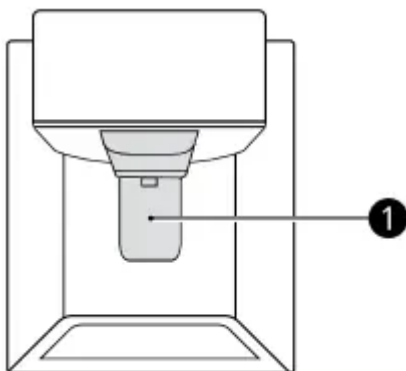

**Using the Measured Fill**

The Measured Fill function dispenses premeasured amounts of water automatically.

1. Select the desired amount from the Measured Fill buttons on the dispenser control panel.

2. Press the dispenser paddle with a container.
3. To stop the measured fill, release the dispenser paddle.

### **Locking the Ice and Water Dispenser**

Press and hold the Lock button for three seconds to lock the dispenser and all the control panel functions. Follow the same instructions to unlock.

### **Ice Compartment**

**CAUTION:** Keep hands and tools out of the ice compartment door and dispenser chute. Failure to do so may result in damage or personal injury.

Keep the ice compartment door closed tightly. If the ice compartment door is not closed tightly, the cold air in the ice bin will freeze food in the refrigerator compartment. This could also cause the icemaker to stop producing ice.

### **In-Door Ice Bin**

The icemaker stops producing ice when the indoor ice bin is full. To make room for additional ice, empty the ice bin into an extra ice bin in the freezer compartment. During use, the ice may stack unevenly in the bin, causing the icemaker to misread the number of ice cubes and stop producing ice. Shaking the ice bin to level the ice within it can reduce this problem

#### **CAUTION:**

- When handling the ice bin, keep hands away from the icemaker tray area to avoid personal injury.
- Storing cans or other items in the ice bin will damage the icemaker.
- Never use thin crystal glasses or containers to collect ice. Such containers may chip or break resulting in glass fragments in the ice.

If the icemaker is turned OFF for an extended period of time, the ice compartment will gradually warm up to the temperature of the refrigerator compartment. To prevent ice cubes from melting and leaking from the dispenser, ALWAYS empty the ice bin when the icemaker is turned OFF for more than a few hours.

The ice passage may become blocked with frost if only crushed ice is used. Remove the frost that accumulates by removing the ice bin and clearing the passage with a rubber spatula. Dispensing cubed ice can also help prevent frost buildup.

### **Detaching the In-Door Ice Bin**

**CAUTION:** Only qualified service personnel from an LG Electronics service center should disassemble or repair the icemaker.

1. Gently pull the handle to open the ice compartment.

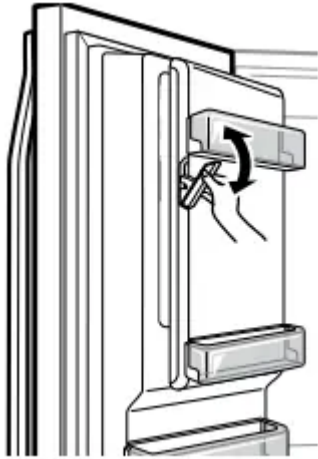

2. To remove the in-door ice bin, grip the front handle, slightly lift the bottom, and slowly pull out the bin as shown.

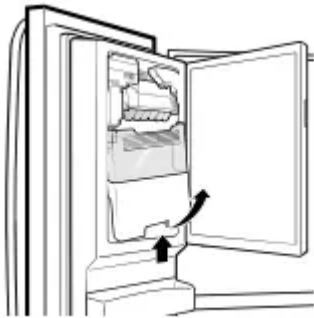

### Assembling the In-Door Ice Bin

#### CAUTION:

- When handling the ice bin, keep hands away from the icemaker tray area to avoid personal injury.
- Avoid touching the auto shutoff (feeler arm) when replacing the ice bin. See the label on the ice compartment door for details.



1. Carefully insert the in-door ice bin, slanting the top slightly to fit it under the icemaker.

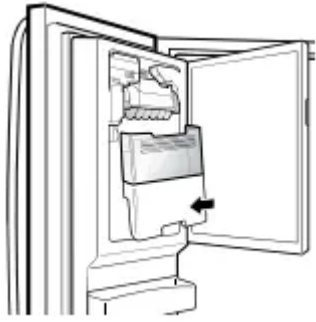

2. Gently push the handle to close the ice compartment.

## Automatic Icemaker

### WARNING:

- DO NOT place fingers in the automatic icemaker when the refrigerator is plugged in.
- Avoid contact with any moving parts of the ejector mechanism or with the heater that releases the ice cubes.

### Before Using the In-Door Icemaker

#### NOTE:

- Ice is made in the automatic in-door icemaker and sent to the dispenser. The icemaker produces 70 - 182 cubes in a 24-hour period, depending on freezer compartment temperature, room temperature, number of door openings and other operating conditions.
- It takes about 12 to 24 hours for a newly installed refrigerator to begin making ice.
- Ice-making stops when the in-door ice bin is full. When full, the in-door ice bin holds approximately 6 to 8 (12-16 oz.) glasses of ice.
- Foreign substances or frost on the ice-detecting sensor can interrupt ice production. Make sure the sensor area is clean at all times for proper operation.
- To increase ice production, use the Ice Plus function. The function increases both ice making and freezing capabilities.

## In-Door Icemaker

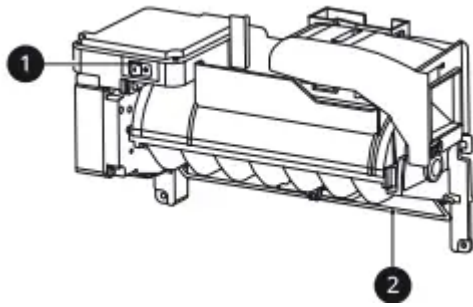

(1) Power switch

(2) Auto shutoff (feeler arm)

## Before Using the Freezer Icemaker

This feature is only available on some models.

The feature may vary depending on model purchased.

### NOTE:

- Throw away the first bin full of ice after installation. This is also necessary if the refrigerator has not been used for a long time.
- The icemaker begins producing ice approximately 48 hours after the appliance is initially installed.
- The sound of ice dropping into the ice bin is normal.
- If the ice bin is completely filled with ice, ice production will stop.
- The amount and shape of ice may vary according to the environment (ambient temperature around the appliance, frequency of the door being opened, amount of food stored in the appliance, water pressure, etc.).
- In the event of a power outage, throw away the ice stored in the ice bin.

## Freezer Icemaker (Cubed Ice)

This feature is only available on some models.

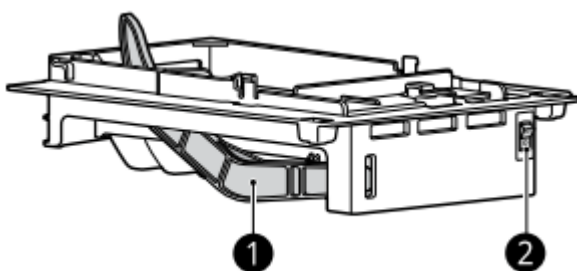

- (1) Feeler Arm
- (2) Power Switch

**NOTE:**

- This automatic freezer icemaker produces 12 cubes at a time, 50-110 pieces within a 24 hour period if conditions are favorable. This amount may vary according to the environment (ambient temperature around the appliance, frequency of the door being opened, amount of food stored in the appliance, etc.).
- Ice cubes which are stored in the ice bin for a long time may clump together and be difficult to separate. If this happens, empty the ice bin completely and clean it before reinstalling it.

### Freezer Icemaker (Craft Ice™)

This feature is only available on some models.

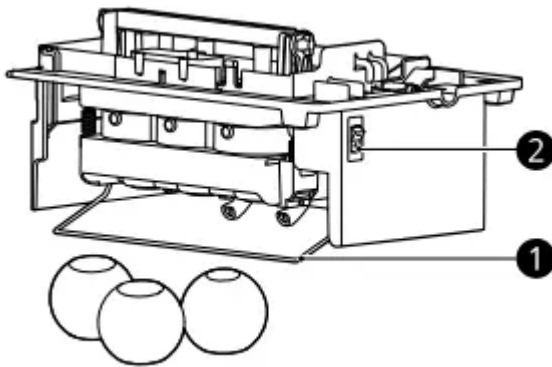

- (1) Feeler Arm
- (2) Power Switch

**CAUTION:** Do not insert round ice into the in-door ice bin, as it can damage the ice and water dispenser.

**NOTE:**

- The icemaker begins producing ice approximately 48 hours after the appliance is initially installed. The first batches of ice may not be round and clear.
- Following installation or water filter replacement, the first few batches of ice may be semicircular or contain air bubbles.
- If the water pressure is less than 20 psi (138 kPa) or a reverse osmosis system is used, the shape of the ice may vary.
- The ice may look cloudy depending on the water quality in the installation location and the operating conditions.

- Throw away any shards of ice you may find in the ice bin, as they may stick to the ice stored in the ice bin.
- After a short term power outage, it will take longer to make the first batch of ice, and the ice may not be round. If the power will be out for a longer period, throw away the ice stored in the ice bin.
- The Craft Ice icemaker produces 1 batch of round ice (3 pieces) at a time.
- In 3 ICE mode (default setting), the Craft Ice icemaker produces 1 batch of round ice (3 pieces) about every 24 hours. In 6 ICE mode, the Craft Ice icemaker produces 2 batches of round ice (6 pieces total) in the same period.
- For more ice, select the 6 ICE mode. For clearer ice, select the 3 ICE mode.
- The time needed to make ice may vary according to operating conditions.
- The ice bin stores 20 - 30 pieces of round ice.

### Turning the Icemaker On/Off

To turn the automatic icemaker On/Off, press the power switch on the icemaker to the ON ( | ) or OFF (O) position.

### Normal Sounds You May Hear

- Keeping the power turned on to the icemaker before the water line is connected can damage the icemaker.
- The icemaker water valve buzzes as the icemaker fills with water. If the icemaker power button is in the ON position, it will buzz even if it has not yet been hooked up to water. To stop the buzzing, press the icemaker power button to turn it off.
- You will hear the sound of ice dropping into the bin and water running in the pipes as the icemaker refills.

### Preparing for Vacation

Set the icemaker power button to OFF and shut off the water supply to the refrigerator

**NOTE:** The ice bin should be emptied any time the icemaker power button is turned to the OFF position.

If the ambient temperature will drop below freezing, have a qualified technician drain the water supply system to prevent serious property damage due to flooding caused by ruptured water lines or connections.

## Humidity Controlled Crispers

### Using the Humidity Controlled Crispers

This feature is only available on some models.

The crispers provide fresher tasting fruit and vegetables by letting you easily control humidity inside the drawer.

You can control the amount of humidity in the moisture-sealed crispers by adjusting the control to any setting between Vegetables and Fruit.

- Vegetables keeps moist air in the crisper for best storage of fresh, leafy vegetables.
- Fruit lets moist air out of the crisper for best storage of fruit.

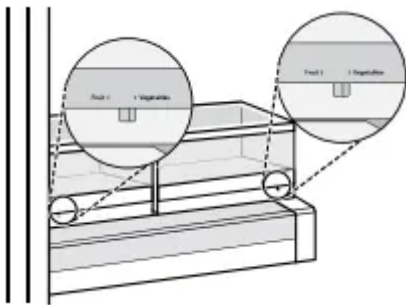

### Removing/Assembling the Humidity Controlled Crispers

1. Open the doors completely and remove the contents of the Door-in-Door case. Lift up and pull out the Door-in-Door case.

**NOTE:** The Door-in-Door feature is only available on some models.

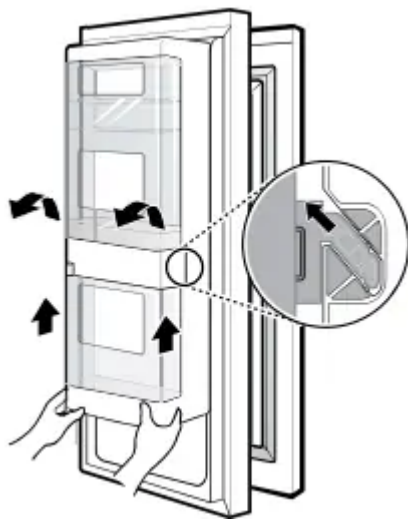

2. Pull out the crisper to full extension, lift the front up, and pull straight out.

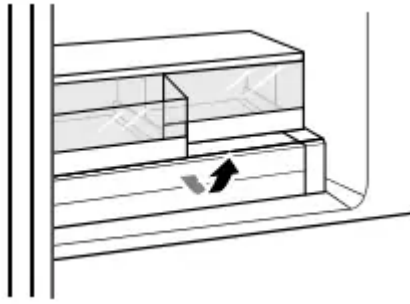

3. To reassemble, slightly tilt up the front, insert the crisper into the frame and push it back into place.

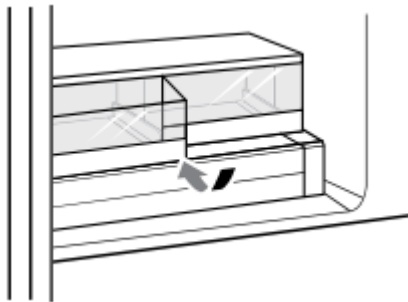

4. Line up the tabs on the Door-in-Door case with the slots on the door and push down until it snaps into place.

**NOTE:** The Door-in-Door feature is only available on some models.

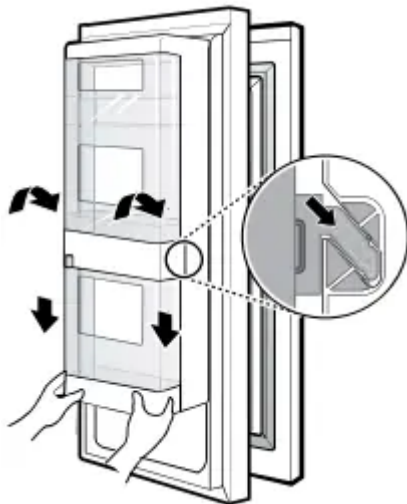

## Glide'N'Serve

### Using the Glide'N'Serve

This function provides storage space with a variable temperature control that can keep the compartment at a slightly different temperature than the refrigerator section. This drawer can be used for large party trays, deli items and beverages. (This drawer should not be used to store vegetables that require high humidity.)

Press the Select button to choose between Produce (Cold), Deli (Colder) and Meat (Coldest).

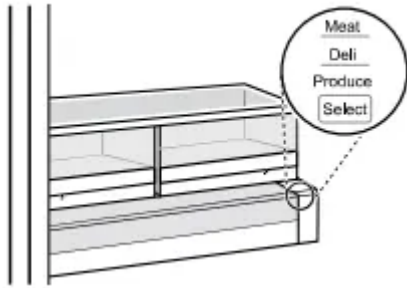

**CAUTION:** Do not place any items on the Glide'N'Serve cover.

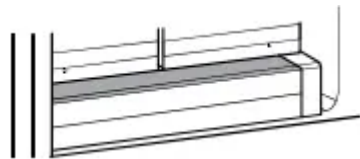

### Detaching/Assembling the Glide'N'Serve

1. To remove the Glide'N'Serve, pull out the drawer until it stops, lift the front up, and pull straight out.

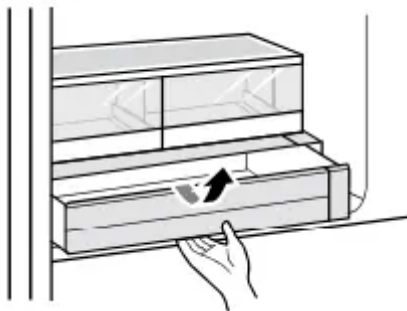

2. To assemble, slightly tilt up the front, insert the drawer into the frame and push it back into place.

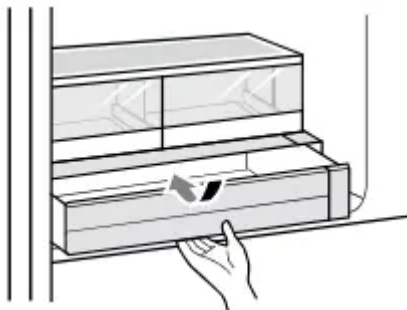

### Refrigerator Shelves

The shelves in the refrigerator are adjustable to meet individual storage needs.

Adjusting the shelves to fit items of different heights will make finding the exact item you want easier.

### Using the Folding Shelf

This feature is only available on some models. Store taller items, such as a gallon container or bottles, by pushing the front half of the shelf underneath the back half of the shelf. Pull the front of the shelf forward to return to a full shelf.

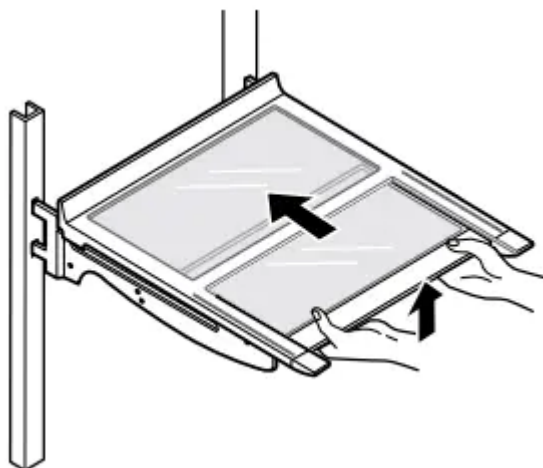

#### CAUTION:

- Glass shelves are heavy. Use special care when removing them.
- Do not clean glass shelves with warm water while they are cold. Shelves may break if exposed to sudden temperature changes or impact.

### Detaching/Assembling the Shelf

**CAUTION:** Do not clean glass shelves with warm water while they are cold. Shelves may break if exposed to sudden temperature changes or impact.

1. To detach, tilt up the front of the shelf and lift the shelf straight up.
2. Pull the shelf out.

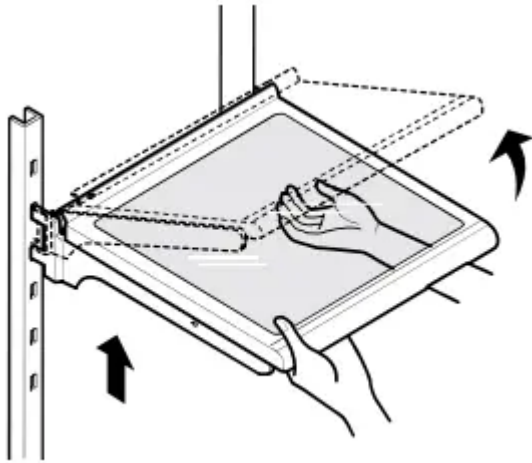

3. To assemble, tilt the front of the shelf up and guide the shelf hooks into the slots at a desired height.

4. Lower the front of the shelf so that the hooks drop into the slots.

**CAUTION:** Make sure that shelves are level from one side to the other. Failure to do so may result in the shelf falling or spilled food.

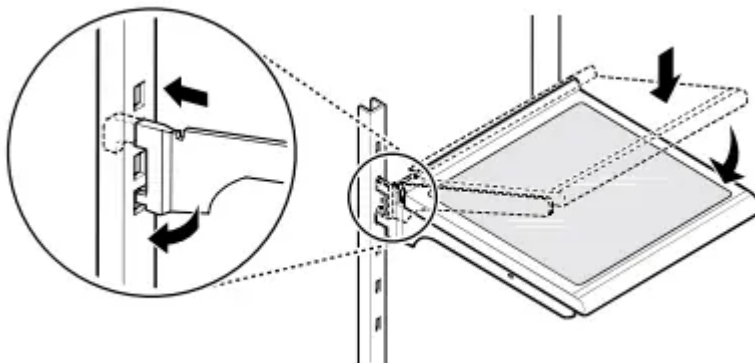

## Door-in-Door

This feature is only available on some models.

The Door-in-Door compartment allows for easy access to commonly used food items.

## Door-in-Door Compartment

This feature is only available on some models.

To access the Door-in-Door compartment, lightly press the button on the right refrigerator door handle.

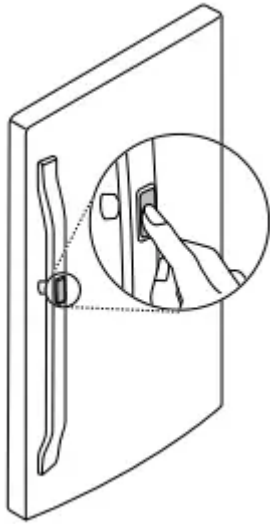

### **Door-in-Door Bin**

The Door-in-Door inner and outer door bins are removable for easy cleaning.

1. To remove the door bins, lift up and pull out.

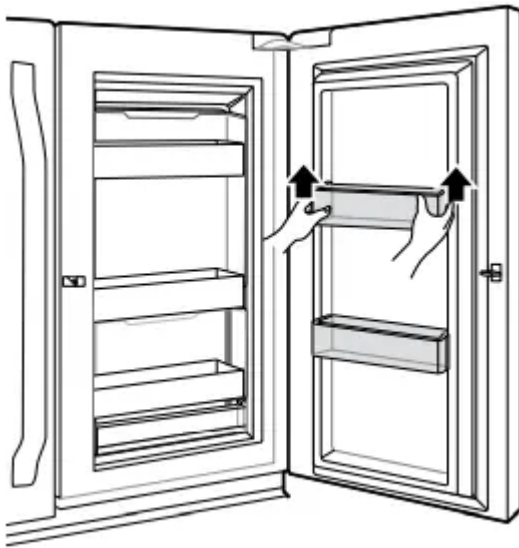

2. To replace the door bins, slide the door bin in above the desired support and push down until it snaps into place.

### **InstaView Door-in-Door**

Knock twice on the glass to turn the LED light inside the InstaView on or off. The LED light turns off automatically after 10 seconds.



**NOTE:**

- The LED light does not turn on if the right refrigerator door is open.
- The InstaView function will not activate for two seconds after closing the door.
- The InstaView function is disabled when the ice dispenser is in use.

**InstaView Door-in-Door Compartment**

The InstaView function on the Door-in-Door compartment lets you view the contents of the compartment without opening the door.

To access the InstaView Door-in-Door compartment, lightly press the button on the right refrigerator door handle.

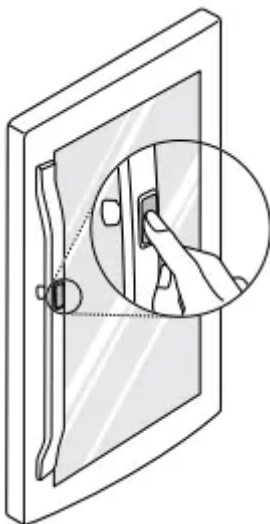

**Door-in-Door Case**

To open the Door-in-Door case, press on the area marked Pull to open. The case is removable for easy cleaning and adjustment.



1. To remove the case, lift up and pull out.

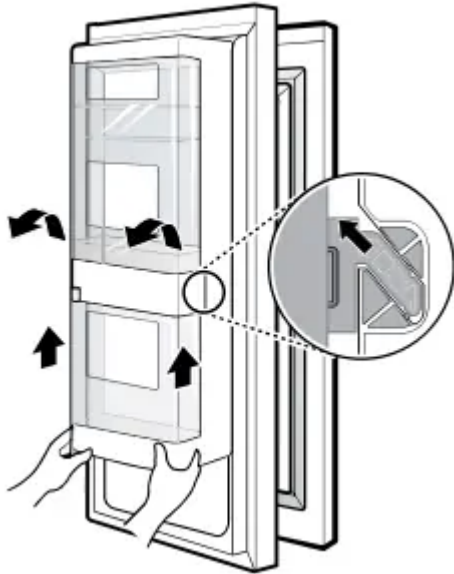

2. To replace the case, line up the tabs on the case with the slots on the door and push down until it snaps into place.

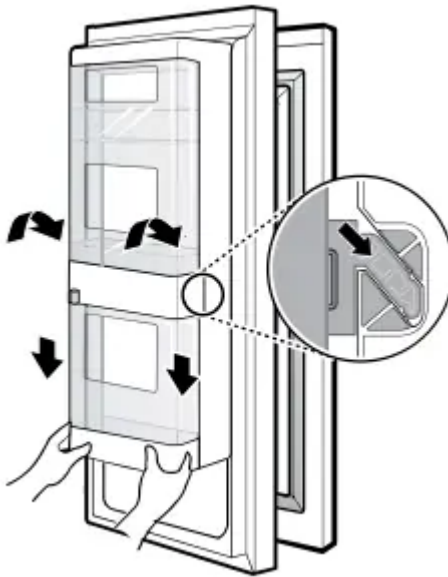

## Door Bins

### Detaching/Assembling Door Bins

The door bins are removable for easy cleaning and adjustment.

1. To remove the bin, simply lift the bin up and pull straight out.

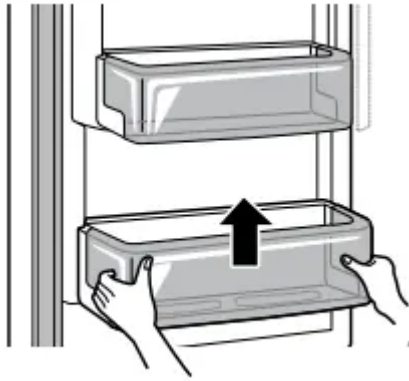

2. To assemble the bin, slide it in above the desired support and push down until it snaps into place.

**CAUTION:**

- Regularly detach and wash the storage bins and shelves; they can become easily contaminated by food.
- Do not apply excessive force while detaching or assembling the storage bins.
- Do not use the dishwasher to clean the storage bins and shelves.

**Durabase**

**Durabase Using the Durabase**

The Durabase divider allows you to organize the Durabase area into 2 sections. It can be adjusted from side to side to accommodate items of different sizes.

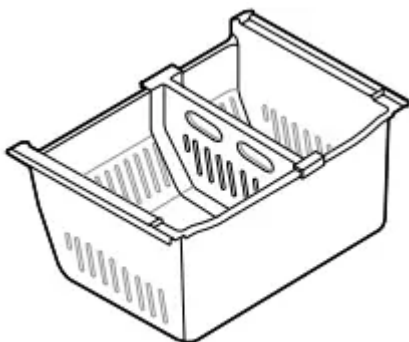

**WARNING:** If the Durabase divider is removed, there is enough open space for children or pets to crawl inside. To prevent accidental child and pet entrapment or suffocation risk, DO NOT allow children or pets to touch or go near the drawer.



# SMART FUNCTIONS

## LG ThinQ Application

This feature is only available on models with Wi-Fi.

The LG ThinQ application allows you to communicate with the appliance using a smartphone.

### LG ThinQ Application Features

- Smart Care+
  - Provides a more personalized experience based on an analysis of your usage patterns.
- Smart Sabbath
  - Activates or deactivates the Sabbath mode and sets the schedule for the mode activation.
- Energy Monitoring
  - This feature keeps track of the refrigerator's power consumption and the number of door openings.
- Remote Control
  - Controls the Refrigerator Temperature, Fresh Air Filter and Ice Plus from the smartphone app.
- Push Messages
  - If the door remains open for more than ten minutes, you will receive a push message. When Ice Plus is finished, you will receive a push message.
- Smart Diagnosis
  - This function provides useful information for diagnosing and solving issues with the appliance based on the pattern of use.
- Settings
  - Allows you to set various options on the refrigerator and in the application.

#### NOTE:

- If you change your wireless router, Internet service provider, or password, delete the registered appliance from the LG ThinQ application and register it again.
- This information is current at the time of publication. The application is subject to change for product improvement purposes without notice to users.

### Before Using LG ThinQ Application

1. Use a smartphone to check the strength of the wireless router (Wi-Fi network) near the appliance.

If the distance between the appliance and the wireless router is too far, the signal becomes weak. It may take a long time to register or fail to install the application.

2. Turn off the Mobile data or Cellular Data on your smartphone.

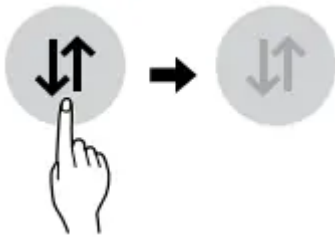

3. Connect your smartphone to the wireless router.

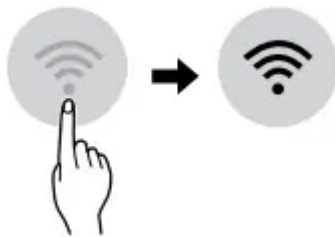

**NOTE:**

- To verify the Wi-Fi connection, check that  icon on the control panel is lit.
- The appliance supports 2.4 GHz Wi-Fi networks only. To check your network frequency, contact your Internet service provider or refer to your wireless router manual.
- LG ThinQ is not responsible for any network connection problems or any faults, malfunctions, or errors caused by network connection.
- The surrounding wireless environment can make the wireless network service run slowly.
- If the appliance is having trouble connecting to the Wi-Fi network, it may be too far from the router. Purchase a Wi-Fi repeater (range extender) to improve the Wi-Fi signal strength.
- The network connection may not work properly depending on the Internet service provider.
- The Wi-Fi may not connect or the connection may be interrupted because of the home network environment.
- If the appliance cannot be registered due to problems with the wireless signal transmission, unplug the appliance and wait about a minute before trying again.
- If the firewall on your wireless router is enabled, disable the firewall or add an exception to it.
- The wireless network name (SSID) should be a combination of English letters and numbers. (Do not use special characters.)

- Smartphone user interface (UI) may vary depending on the mobile operating system (OS) and the manufacturer.
- If the security protocol of the router is set to WEP, network setup may fail. Change the security protocol (WPA2 is recommended), and register the product again.

## Installing the LG ThinQ Application

Search for the LG ThinQ application from the Google Play Store or Apple App Store on a smartphone. Follow instructions to download and install the application.

## Connecting to Wi-Fi

The Wi-Fi button, when used with the LG ThinQ application, allows the appliance to connect to a home Wi-Fi network. The  icon shows the status of the appliance's network connection. The icon illuminates when the appliance is connected to the Wi-Fi network.

- Initial Appliance Registration

Run the LG ThinQ application and follow the instructions in the application to register the appliance.

- Re-registering the Appliance or Registering Another User

Press and hold the Wi-Fi button for 3 seconds to temporarily turn it off. Run the LG ThinQ application and follow the instructions in the application to register the appliance.

**NOTE:** To disable the Wi-Fi function, press and hold the Wi-Fi button for 3 seconds. The  icon will be turned off.

## Wireless LAN Module Specifications

The Wi-Fi module specifications can be found on the label inside the appliance.

## LCW-004†

<b>Model</b>	LCW-004
<b>Frequency Range</b>	2412 - 2462 MHz
<b>Output Power (Max)</b>	< 30 dBm

## LCW-007†

<b>Model</b>	LCW-007
<b>Frequency Range</b>	2412 - 2462 MHz
<b>Output Power (Max)</b>	< 30 dBm

† This feature is only available on some models.

### FCC Notice

The following notice covers the transmitter module contained in this product.

This equipment has been tested and found to comply with the limits for a Class B digital device, pursuant to Part 15 of the FCC Rules. These limits are designed to provide reasonable protection against harmful interference in a residential installation. This equipment generates, uses, and can radiate radio frequency energy and, if not installed and used in accordance with the instructions, may cause harmful interference to radio communications. However, there is no guarantee that interference will not occur in a particular installation. If this equipment does cause harmful interference to radio or television reception, which can be determined by turning the equipment off and on, the user is encouraged to try to correct the interference by one or more of the following measures:

- Reorient or relocate the receiving antenna.
- Increase the separation between the equipment and the receiver.
- Connect the equipment into an outlet on a circuit different from that to which the receiver is connected.
- Consult the dealer or an experienced radio/TV technician for help.

This device complies with part 15 of the FCC Rules. Operation is subject to the following two conditions:

- (1) This device may not cause harmful interference and
- (2) This device must accept any interference received, including interference that may cause undesired operation.

Any changes or modifications in construction of this device which are not expressly approved by the party responsible for compliance could void the user's authority to operate the equipment.

### **FCC RF Radiation Exposure Statement**

This equipment complies with FCC radiation exposure limits set forth for an uncontrolled environment. This transmitter must not be collocated or operating in conjunction with any other antenna or transmitter.

This equipment should be installed and operated with a minimum distance of 20 cm (7.8 inches) between the antenna and your body. Users must follow the specific operating instructions for satisfying RF exposure compliance.

### **Industry Canada Statement**

This device contains licence-exempt transmitter(s)/ receiver(s) that comply with Innovation, Science and Economic Development Canada's licence-exempt RSS(s). Operation is subject to the following two conditions:

- (1) This device may not cause interference.
- (2) This device must accept any interference, including interference that may cause undesired operation of the device.

### **IC Radiation Exposure Statement**

This equipment complies with IC radiation exposure limits set forth for an uncontrolled environment.

This equipment should be installed and operated with a minimum distance of 20 cm (7.8 inches) between the antenna and your body.

**NOTE:** THE MANUFACTURER IS NOT RESPONSIBLE FOR ANY RADIO OR TV INTERFERENCE CAUSED BY UNAUTHORIZED MODIFICATIONS TO THIS EQUIPMENT. SUCH MODIFICATIONS COULD VOID THE USER'S AUTHORITY TO OPERATE THE EQUIPMENT.

## Open Source Software Notice Information

To obtain the source code under GPL, LGPL, MPL, and other open source licenses, that is contained in this product, please visit <http://opensource.lge.com>. In addition to the source code, all referred license terms, warranty disclaimers and copyright notices are available for download.

LG Electronics will also provide open source code to you on CD-ROM for a charge covering the cost of performing such distribution (such as the cost of media, shipping, and handling) upon email request to [opensource@lge.com](mailto:opensource@lge.com). This offer is valid for a period of three years after our last shipment of this product. This offer is valid to anyone in receipt of this information.

## Smart Grid Function

When the refrigerator operates in Smart Grid mode, the Smart Refrigerator function can control energy usage or delay the operation of some functions to save energy during peak usage periods.

- You can override the Smart Grid function any time (using the Smart Grid button or application).
- To use the Smart Grid function, you need to register your application with your electric utility company, provided that your electric utility company supports the function. In other words, the Smart Grid function will not be available if your electric utility company does not support the function or does not have the capability to support the function.

## Smart Grid Application Features

- Smart Saving\_Demand Response
  - You can lower energy usage based on Demand Response (DR) signals from the utility company. If the refrigerator is operating in Smart Saving mode according to the DR signal, you can see a pop up.
- Seasonal Energy Savings
  - Lower energy usage based on time period.

## Using the Smart Grid Function

This feature responds to notification events from your utility company to run high energy consuming tasks during off-peak periods when demand is lower. These notification events are known as Demand Response signals.

If the refrigerator receives a Demand Response signal from the utility company, the refrigerator will turn on the Grid LED on the refrigerator display and control its power consumption according to the signal. The refrigerator will respond to the signals received from the utility company as long as product performance is maintained.

If the refrigerator receives a Demand Response signal, the refrigerator will operate in Delay Appliance Load (DAL) or Temporary Appliance Load Reduction (TALR) mode.

### **Delay Appliance Load (DAL)**

The refrigerator responds to a DAL signal by providing a moderate load reduction for the duration of the delay period.

This mode controls functions that consume a lot of energy such as adjusting the cooling system, running the defrost cycle, and making ice.

- When the refrigerator operates in DAL mode, the Grid LED is illuminated on the refrigerator display.
- DAL mode is automatically deactivated after the period stipulated by the DAL signal (max. 4 hours) or when you override the Smart Grid function.

### **Temporary Appliance Load Reduction (TALR)**

The refrigerator responds to a TALR signal by aggressively reducing the load for a short time period, typically 10 minutes. This mode reduces energy consumption by stopping the compressor and controlling the functions that consume a lot of energy such as the defrost cycle and fan.

- When the refrigerator operates in TALR mode, the Grid LED is illuminated on the refrigerator display.
- TALR mode is automatically deactivated after the received duration (max. 10 minutes), or when you override the Smart Grid function. The mode is immediately deactivated and the refrigerator returns to its normal state when the door is opened or closed, or the dispenser is used.

### **Override Smart Grid Mode**

To ignore the Demand Response signal from the utility company and override the Smart Grid function, push the Smart Grid button while the refrigerator is in Smart Grid mode.

When you override the Smart Grid function, the refrigerator ignores the Demand Response signal and is no longer controlled by the utility company until the next Demand Response signal is sent. You can also override the Smart Grid function using the smart phone app.

### **LG Open API**

You can manage Smart Grid features for the LG Smart Refrigerator.



Please check the detailed specifications

#### **API List**

- Demand Response
  - Send demand response signal

- Power Saving
  - Set saving mode
  - Get schedule of DR/Delay Defrost
- Energy Monitoring
  - Get door open event
  - Get energy consumption
- Delay Defrost Capability
  - Insert a delay defrost schedule event
  - Update a delay defrost schedule event
  - Delete a delay defrost schedule event
  - Get the delay defrost schedule

## Smart Diagnosis Feature

This feature is only available on models with the  or  logo.

Use this feature to help you diagnose and solve problems with your appliance.

### NOTE

- For reasons not attributable to LGE's negligence, the service may not operate due to external factors such as, but not limited to, Wi-Fi unavailability, Wi-Fi disconnection, local app store policy, or app unavailability.
- The feature may be subject to change without prior notice and may have a different form depending on where you are located

## Using LG ThinQ to Diagnose Issues

If you experience a problem with your Wi-Fi equipped appliance, it can transmit troubleshooting data to a smartphone using the LG ThinQ application.

Launch the LG ThinQ application and select the Smart Diagnosis feature in the menu.

Follow the instructions provided in the LG ThinQ application.

## Using Audible Diagnosis to Diagnose Issues

Follow the instructions below to use the audible diagnosis method.

Launch the LG ThinQ application and select the Smart Diagnosis feature in the menu.

Follow the instructions for audible diagnosis provided in the LG ThinQ application.

1. Hold the Lock button for three seconds.

If the display has been locked for over five minutes, you must deactivate the lock and then reactivate it.

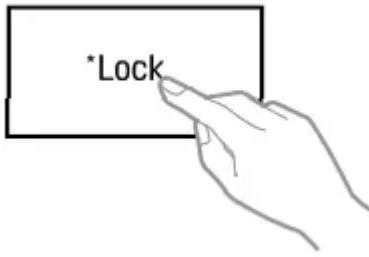

2. Open the right refrigerator door.
3. Hold the mouthpiece of your phone in front of the speaker that is located on the right hinge of the refrigerator door.

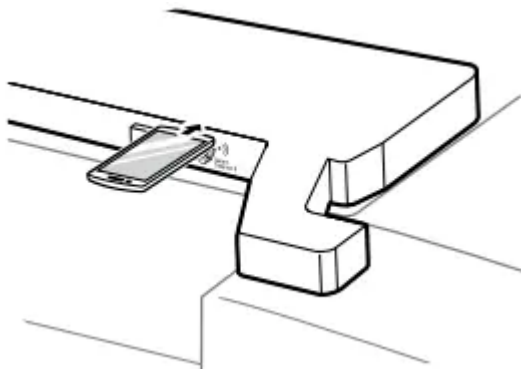

4. Press and hold the Freezer button for three seconds while continuing to hold your phone to the speaker.



5. After you hear three beeps, release the Freezer button.
6. Keep the phone in place until the tone transmission has finished. The display will count down the time. Once the countdown is over and the tones have stopped, the diagnosis will be displayed in the application.

**NOTE:** For best results, do not move the phone while the tones are being transmitted.

## MAINTENANCE

### Cleaning

**WARNING:** Use non-flammable cleaner. Failure to do so can result in fire, explosion, or death.

**CAUTION:**

- Do not use an abrasive cloth or sponge when cleaning the interior and exterior of the refrigerator.
- Do not place your hand on the bottom surface of the refrigerator when opening and closing the doors.

**General Cleaning Tips**

- Both the refrigerator and freezer sections defrost automatically; however, clean both sections once a month to prevent odors.
- Wipe up spills immediately.
- Unplug the refrigerator or disconnect power before cleaning.
- Remove all removable parts, such as shelves.
- Use a clean sponge or soft cloth and a mild detergent in warm water. Do not use abrasive or harsh cleaners.
- Hand wash, rinse and dry all surfaces thoroughly.

**Exterior**

For products with black stainless steel exterior, spray glass cleaner on a clean microfiber cloth and rub in direction of grain. Do not spray glass cleaner directly at the display panel. Do not use harsh or abrasive cleaners.

For products with a standard stainless steel exterior, use a damp microfiber cloth and rub in the direction of the grain. Dry with a paper towel to avoid streaks. For stubborn stains and fingerprints, use a few drops of liquid dish soap in water, and rinse with hot water before drying. Do not use abrasive or harsh cleaners.

**Inside Walls**

Allow freezer to warm up so the cloth will not stick.

To help remove odors, wash the inside of the refrigerator with a mixture of baking soda and warm water. Mix 2 tablespoons of baking soda to 1 quart of water (26 g soda to 1 liter water.) Be sure the baking soda is completely dissolved so it does not scratch the surfaces of the refrigerator.

**Door Liners and Gaskets**

Use a clean sponge or soft cloth and a mild detergent in warm water. Do not use cleaning waxes, concentrated detergents, bleaches, or cleaners containing petroleum on plastic refrigerator parts.

## Plastic Parts (Covers and Panels)

Use a clean sponge or soft cloth and a mild detergent in warm water. Do not use glass cleaners, abrasive cleansers, or flammable fluids. These can scratch or damage the material.

## Condenser Coils

Use a vacuum cleaner with a brush or crevice attachment to clean the condenser cover and vents. Do not remove the panel covering the condenser coil area.

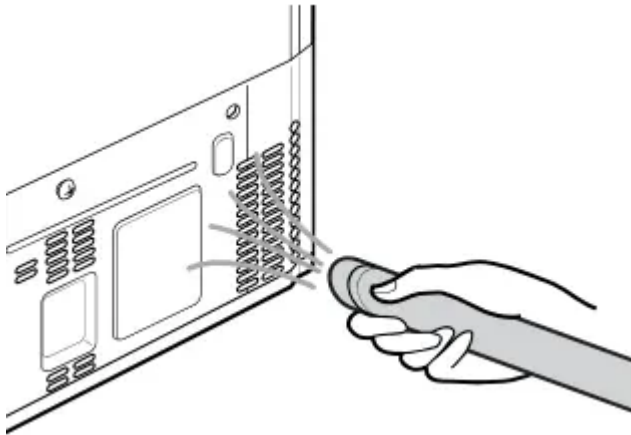

## Air Filter

### Replacing the Fresh Air Filter

Replace the Fresh Air Filter:

- Approximately every six months.
- When the Replace Filter  icon turns on.
- Use replacement air filter: LT120F

1. Rotate the filter cover counterclockwise to release the tabs, and remove the cover.

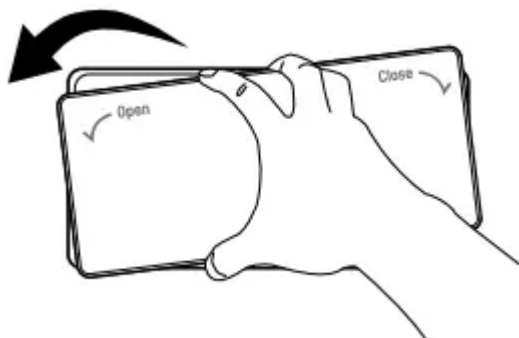

2. Remove the filter from the inside of the cover by pressing the side of the filter in and pulling the center out.

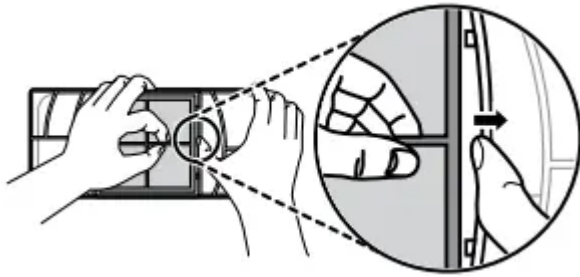

3. Place the new filter inside of the cover with the side that says FRONT facing outward.

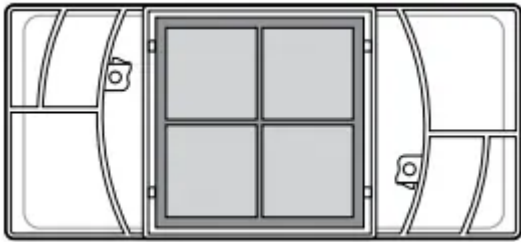

4. Align tabs 1 on the filter cover with hooks 2 on the refrigerator wall.

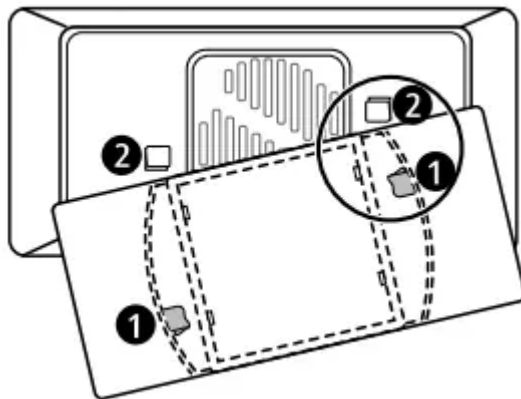

5. Rotate the air filter cover clockwise until the hooks engage and the cover locks in place.

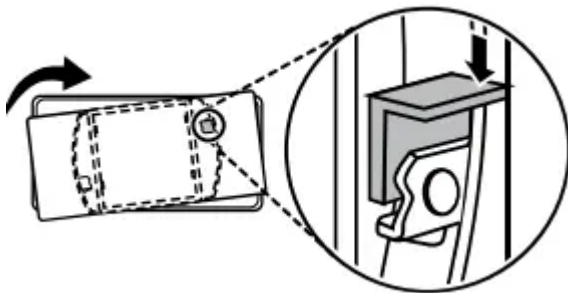

6. Press and hold the Fresh Air Filter button on the control panel for 3 seconds to reset the filter sensor.



## Water Filter

### Before Replacing the Water Filter

#### WARNING:

To reduce the risk associated with choking, do not allow children under 3 years of age to have access to small parts during the installation of this product.

To reduce the risk associated with the ingestion of contaminants, do not use with water that is microbiologically unsafe or of unknown quality without adequate disinfection before or after the system. Systems certified for cyst reduction may be used on disinfected water that may contain filterable cysts.

Use of unauthorized water filters may result in product malfunction, water leakage or water quality issues, which will not be covered under the product warranty.

#### CAUTION:

- Read and follow Use Instructions before installation and use of this system.
- Installation and use MUST comply with all state and local plumbing codes.
- Do not install if water pressure exceeds 120 psi (827 kPa). If your water pressure exceeds 80 psi, you must install a pressure limiting valve. Contact a plumber if uncertain how to check your water pressure.
- Do not install where water hammer conditions may occur. If water hammer conditions exist you must install a water hammer arrester. Contact a plumbing professional if you are uncertain how to check for this condition.
- Do not install on hot water supply lines. The maximum operating water temperature of this filter system is 100 °F (37.8 °C).
- Protect filter from freezing. Drain filter when temperatures drop below 40 °F (4.4 °C).
- The disposable filter cartridge MUST be replaced every 6 months, at the rated capacity or if a noticeable reduction in flow rate occurs.
- To protect it from freezing, remove filter cartridge when temperatures are expected to drop below 33° F.
- Do not install systems in areas where ambient temperatures may go above 110° F (43.3° C).
- Where a backflow prevention device is installed on a water system, a device for controlling pressure due to thermal expansion must be installed.
- Ensure all tubing and fittings are secure and free from leaks

## Replacing the Water Filter

Replace the water filter:

- Approximately every six months.
- When the Replace Filter  icon turns on.
- When the water dispenser output decreases.

To purchase a replacement water filter:

- Visit your local dealer or distributor
- Search using "water filter" on lg.com
- Use replacement cartridge: LT1000P, LT1000PC, LT1000PCS or ADQ747935\*\*

1. Remove the door bin.

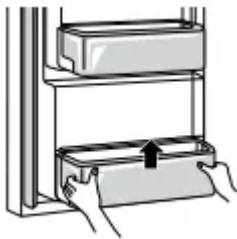

2. Remove the disposable water filter.

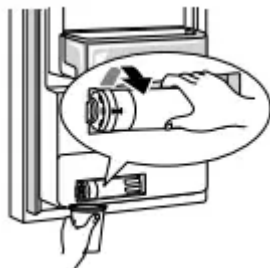

### NOTE:

- Replacing the water filter causes a small amount of water (around 1 oz. or 25 cc) to drain.
  - Wrap a cloth around the front end of the water filter cover to collect any leaking water. Hold the water filter upright, once it is removed, to prevent any remaining water from spilling out of the water filter.
3. Replace with a new water filter. Insert the new filter into the filter head and rotate it clockwise until the arrow on the new filter lines up with the arrow on the filter head. Swing the filter back into the compartment.

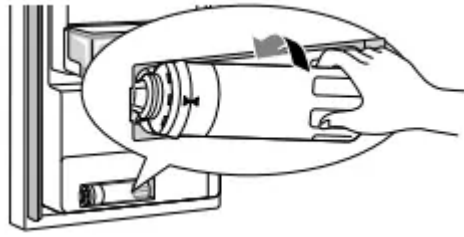

4. Replace the door bin.

5. After changing the filter, press and hold the Water Filter button for three seconds to reset the indicator light.

6. After the water filter is replaced, dispense 2.5 gallons of water (flush for approximately 5 minutes) to remove trapped air and contaminants from the system.

**NOTE:** Do not dispense the entire 2.5 gallon amount continuously. Press and release the dispenser pad for cycles of 30 seconds ON and 60 seconds OFF.

**CAUTION:** LG strongly recommends that you use LG authorized water filters to prevent water quality issues, water leakage and appliance malfunction.

## TROUBLESHOOTING

### FAQs

**Q: What are the best temperature settings for my refrigerator and freezer?**

A: The default setting for the refrigerator is 37° Fahrenheit (3° Celsius). The default setting for the freezer is 0° Fahrenheit (-18° Celsius). Adjust these settings as necessary to keep food at desired temperatures. Milk should be cold when stored on the inner shelf of the refrigerator. Ice cream should be firm and ice cubes should not melt in the freezer. To switch the display from Fahrenheit to Celsius, press and hold the Freezer and Refrigerator buttons until you hear a beep and the settings in the display change.

**Q: How do I set the refrigerator and freezer temperatures?**

A: Continually press the Refrigerator or Freezer button on the control panel until the desired temperature appears. The numbers will cycle from highest to lowest and then return to the highest again with continuous pressing.

**Q: Why do I hear a buzzing noise from my refrigerator periodically?**

A: This may happen if you do not have a water source attached to your refrigerator and the icemaker is turned on. If you do not have a water source attached to the back of the refrigerator you should turn the icemaker off.

**Q: Why does the icemaker tray look crooked?**

A: This is a normal part of the icemaker cycle. The icemaker tray may appear level or with a slight tilt. The change in position is to assist in the freezing process.

**Q: My refrigerator is powered on and the controls are working, but it is not cooling and the display shows OFF (see below). What is wrong?**

A: The refrigerator is in Display Mode. The Display Mode disables all cooling in the refrigerator and freezer sections to conserve energy while on display in a retail store. When activated, OFF is displayed on the control panel and the display remains on for 20 seconds. With either refrigerator door opened, press the Ice Plus button 3 times consecutively while pressing the Refrigerator button. The control panel beeps and the temperature settings display to confirm that Display Mode is deactivated. Use the same procedure to activate Display Mode.



## Before Calling for Service

Review this section before calling for service; doing so will save you both time and money.

## Cooling



Problem	Possible Cause & Solution
<p><b>Refrigerator is not cooling or has no power.</b></p>	<p><b>A fuse in your home may be blown or the circuit breaker tripped. Or the appliance is connected to a GFCI (Ground Fault Circuit Interrupter) outlet, and the outlet circuit breaker has tripped.</b></p> <ul style="list-style-type: none"> <li>• Check the main electrical box and replace the fuse or reset the circuit breaker. Do not increase fuse capacity. If the problem is a circuit overload, have it corrected by a qualified electrician.</li> <li>• Reset the circuit breaker on the GFCI. If the problem persists, contact an electrician.</li> </ul>
	<p><b>The refrigerator control is set to OFF (some models).</b></p> <ul style="list-style-type: none"> <li>• Turn the control ON. Refer to the Setting the Controls section for proper temperature settings.</li> </ul>
	<p><b>Refrigerator is set to Demo Mode.</b></p> <ul style="list-style-type: none"> <li>• Demo Mode allows the lights and control display to work normally while disabling cooling, to save energy while the refrigerator is on the showroom floor. See the Features section of this manual for instructions on how to disable Demo Mode.</li> </ul>
	<p><b>Refrigerator is in the defrost cycle.</b></p> <ul style="list-style-type: none"> <li>• During the defrost cycle, the temperature of each compartment may rise slightly. Wait 30 minutes and confirm the proper temperature has been restored once the defrost cycle has completed.</li> </ul>
	<p><b>Refrigerator was recently installed.</b></p> <ul style="list-style-type: none"> <li>• It may take up to 24 hours for each compartment to reach the desired temperature.</li> </ul>
	<p><b>Refrigerator was recently relocated.</b></p> <ul style="list-style-type: none"> <li>• If the refrigerator was stored for a long period of time or moved on its side, it is necessary for the refrigerator to stand upright for 24 hours before connecting it to power.</li> </ul>
<p><b>Cooling system runs too much.</b></p>	<p><b>Refrigerator is replacing an older model.</b></p> <ul style="list-style-type: none"> <li>• Modern refrigerators require more operating time but use less energy due to more efficient technology.</li> </ul>



Problem	Possible Cause & Solution
	<p data-bbox="587 277 1334 309"><b>Refrigerator was recently plugged in or power restored.</b></p> <ul data-bbox="587 338 1334 369" style="list-style-type: none"> <li data-bbox="587 338 1334 369">• The refrigerator will take up to 24 hours to cool completely.</li> </ul> <hr/> <p data-bbox="587 450 1570 481"><b>The door is opened often or a large amount of food / hot food was added.</b></p> <ul data-bbox="587 510 1596 719" style="list-style-type: none"> <li data-bbox="587 510 1596 719">• Adding food and opening the door warms the refrigerator, requiring the compressor to run longer in order to cool the refrigerator back down. In order to conserve energy, get everything you need out of the refrigerator at once, keep food organized so it is easy to find, and close the door as soon as the food is removed. (Refer to the Food Storage Guide.)</li> </ul> <hr/> <p data-bbox="587 799 1031 831"><b>Doors are not closed completely.</b></p> <ul data-bbox="587 860 1596 936" style="list-style-type: none"> <li data-bbox="587 860 1596 936">• Firmly push the doors shut. If they will not shut all the way, the "Doors will not close correctly or pop open" section in Troubleshooting.</li> </ul> <hr/> <p data-bbox="587 1016 1136 1048"><b>Refrigerator is installed in a hot location.</b></p> <ul data-bbox="587 1077 1596 1240" style="list-style-type: none"> <li data-bbox="587 1077 1596 1240">• The compressor will run longer under warm conditions. At normal room temperature (70 °F or 21 °C) expect your compressor to run about 40 % to 80 % of the time. Under warmer conditions, expect it to run even more often. The refrigerator should not be operated above 110 °F (43 °C).</li> </ul> <hr/> <p data-bbox="587 1321 1062 1352"><b>Condenser / back cover is clogged.</b></p> <ul data-bbox="587 1382 1596 1458" style="list-style-type: none"> <li data-bbox="587 1382 1596 1458">• Use a vacuum cleaner with an attachment to clean the condenser cover and vent. Do not remove the panel covering the condenser coil area.</li> </ul>
<p data-bbox="252 1525 480 1601"><b>Interior moisture buildup.</b></p>	<p data-bbox="587 1541 1273 1572"><b>Doors are opened often or for long periods of time.</b></p> <ul data-bbox="587 1601 1596 1720" style="list-style-type: none"> <li data-bbox="587 1601 1596 1720">• When the doors are opened often or for long periods of time, warm, humid air enters the compartment. This raises the temperature and moisture level within the compartment. To lessen the effect, reduce the frequency and duration of door openings.</li> </ul> <hr/> <p data-bbox="587 1800 1002 1832"><b>Doors are not closed correctly.</b></p> <ul data-bbox="587 1861 1353 1892" style="list-style-type: none"> <li data-bbox="587 1861 1353 1892">• See the "Doors will not close correctly or pop open" section.</li> </ul>



Problem	Possible Cause & Solution
	<p><b>Weather is humid.</b></p> <ul style="list-style-type: none"> <li>Humid weather allows additional moisture to enter the compartments when the doors are opened leading to condensation or frost. Maintaining a reasonable level of humidity in the home will help to control the amount of moisture that can enter the compartments.</li> </ul> <p><b>Defrost cycle recently completed.</b></p> <ul style="list-style-type: none"> <li>During the defrost cycle, the temperature of each compartment may rise slightly and condensation may form on the back wall. Wait 30 minutes and confirm that the proper temperature has been restored once the defrost cycle has completed.</li> </ul> <p><b>Food is not packaged correctly.</b></p> <ul style="list-style-type: none"> <li>Food stored uncovered or unwrapped, and damp containers can lead to moisture accumulation within each compartment. Wipe all containers dry and store food in proper packaging to prevent condensation and frost.</li> </ul>
<p><b>Food is freezing in the refrigerator compartment.</b></p>	<p><b>Food with high water content was placed near an air vent.</b></p> <ul style="list-style-type: none"> <li>Rearrange items with high water content away from air vents.</li> </ul> <p><b>Refrigerator temperature control is set incorrectly.</b></p> <ul style="list-style-type: none"> <li>If the temperature is too cold, adjust the control one increment at a time and wait for the temperature to stabilize. Refer to the Control Panel section for more information.</li> </ul> <p><b>Refrigerator is installed in a cold location.</b></p> <ul style="list-style-type: none"> <li>When the refrigerator is operated in temperature below 41 °F (5 °C), food can freeze in the refrigerator compartment. The refrigerator should not be operated in temperatures below 55 °F (13 °C).</li> </ul>
<p><b>Refrigerator or Freezer section is too cold.</b></p>	<p><b>Incorrect temperature control settings.</b></p> <ul style="list-style-type: none"> <li>If the temperature is too cold, adjust the control one increment at a time and wait for the temperature to stabilize. Refer to the Control Panel for more information.</li> </ul>



Problem	Possible Cause & Solution
<b>Frost or ice crystals form on frozen food (inside of sealed package).</b>	<p><b>Condensation from food with a high water content has frozen inside of the package.</b></p> <ul style="list-style-type: none"> <li>• This is normal for food items with a high water content.</li> </ul>
	<p><b>Food has been left in the freezer for a long period of time.</b></p> <ul style="list-style-type: none"> <li>• Do not store food items with high water content in the freezer for a long period of time.</li> </ul>
<b>Frost or ice crystals form on frozen food (outside of package).</b>	<p><b>Door is opened frequently or for long periods of time.</b></p> <ul style="list-style-type: none"> <li>• When the doors are opened often or for long periods of time, warm, humid air enters the compartment. This raises the temperature and moisture level within the compartment. Increased moisture will lead to frost and condensation. To lessen the effect, reduce the frequency and duration of door openings.</li> </ul>
	<p><b>Door is not closing properly.</b></p> <ul style="list-style-type: none"> <li>• Refer to the "Doors will not close correctly or pop open" section in the Troubleshooting section.</li> </ul>
<b>Refrigerator or Freezer section is too warm.</b>	<p><b>Refrigerator was recently installed.</b></p> <ul style="list-style-type: none"> <li>• It may take up to 24 hours for each compartment to reach the desired temperature.</li> </ul>
	<p><b>The air vents are blocked. Cold air circulates from the freezer to the fresh food section and back again through air vents in the wall dividing the two sections.</b></p> <ul style="list-style-type: none"> <li>• Locate air vents by using your hand to sense airflow and move all packages that are blocking the vents and restrict airflow. Rearrange items to allow air to flow throughout the compartment.</li> </ul>
	<p><b>Doors are opened often or for long periods of time.</b></p> <ul style="list-style-type: none"> <li>• When the doors are opened often or for long periods of time, warm, humid air enters the compartment. This raises the temperature and moisture level within the compartment. To lessen the effect, reduce the frequency and duration of door openings.</li> </ul>
	<p><b>Unit is installed in a hot location.</b></p> <ul style="list-style-type: none"> <li>• The refrigerator should not be operated in temperatures above 110 °F (43 °C).</li> </ul>



Problem	Possible Cause & Solution
	<p><b>A large amount of food or hot food was added to either compartment.</b></p> <ul style="list-style-type: none"> <li>• Adding food warms the compartment requiring the cooling system to run. Allowing food to cool to room temperature before putting it in the refrigerator will reduce the effect.</li> </ul>
	<p><b>Doors are not closed correctly.</b></p> <ul style="list-style-type: none"> <li>• See the "Doors will not close correctly or pop open" section in the Troubleshooting section.</li> </ul>
	<p><b>Temperature control is not set correctly.</b></p> <ul style="list-style-type: none"> <li>• If the temperature is too warm, adjust the control one increment at a time and wait for the temperature to stabilize.</li> </ul>
	<p><b>Defrost cycle has recently completed.</b></p> <ul style="list-style-type: none"> <li>• During the defrost cycle, the temperature of each compartment may rise slightly and condensation may form on the back wall. Wait 30 minutes and confirm the proper temperature has been restored once the defrost cycle has completed.</li> </ul>

## Craft Ice

Problem	Possible Cause & Solution
<p><b>Icemaker is not making ice.</b></p>	<p><b>Refrigerator was recently installed or icemaker recently connected.</b></p> <ul style="list-style-type: none"> <li>• The icemaker begins producing ice approximately 48 hours after the appliance is initially installed. The first batches of ice may not be round and clear.</li> </ul>
<p><b>Icemaker is not making enough ice.</b></p>	<p><b>In 3 ICE mode (default setting), the Craft Ice icemaker produces 1 batch of ice about every 24 hours.</b></p> <ul style="list-style-type: none"> <li>• For more ice, select the 6 ICE mode.</li> </ul>

Ice



Problem	Possible Cause & Solution
<p><b>Icemaker is not making enough ice.</b></p>	<p><b>Demand exceeds ice storage capacity.</b></p> <ul style="list-style-type: none"> <li>• The icemaker will produce approximately 70-184 cubes in a 24 hour period.</li> </ul>
	<p><b>House water supply is not connected, valve is not turned on fully, or valve is clogged.</b></p> <ul style="list-style-type: none"> <li>• Connect the refrigerator to a cold water supply with adequate pressure and turn the water shutoff valve fully open. If the problem persists, it may be necessary to contact a plumber.</li> </ul>
	<p><b>Water filter has been exhausted.</b></p> <ul style="list-style-type: none"> <li>• Replacing the water filter is recommended: <ul style="list-style-type: none"> <li>- Approximately every six months.</li> <li>- When the water filter indicator turns on.</li> <li>- When the water dispenser output decreases.</li> <li>- When the ice cubes are smaller than normal.</li> </ul> </li> </ul>
	<p><b>Low house water supply pressure.</b></p> <ul style="list-style-type: none"> <li>• The water pressure must be between 20 and 120 psi (138 and 827 kPa) on models without a water filter and between 40 and 120 psi (276 and 827 kPa) on models with a water filter. If the problem persists, it may be necessary to contact a plumber.</li> </ul>
	<p><b>Reverse osmosis filtration system is used.</b></p> <ul style="list-style-type: none"> <li>• Reverse osmosis filtration systems can reduce the water pressure below the minimum amount and result in icemaker issues. (Refer to the Connecting the Water Line section for more information.)</li> </ul>
	<p><b>Tubing connecting refrigerator to house supply valve is kinked.</b></p> <ul style="list-style-type: none"> <li>• The tubing can kink when the refrigerator is moved during installation or cleaning, resulting in reduced water flow. Straighten or repair the water supply line and arrange the tubing to prevent future kinks.</li> </ul>
	<p><b>Doors are opened often or for long periods of time.</b></p>



Problem	Possible Cause & Solution
	<ul style="list-style-type: none"> <li>• If the doors of the unit are opened often, ambient air will warm the refrigerator and will prevent the unit from maintaining the set temperature. Lowering the refrigerator temperature can help, as well as not opening the doors as frequently.</li> </ul> <p><b>Doors are not closed completely.</b></p> <ul style="list-style-type: none"> <li>• If the doors are not properly closed, ice production will be affected. See the "Doors not close correctly or pop open" section in Parts &amp; Features Troubleshooting for more information.</li> </ul> <p><b>The temperature setting for the freezer is too warm.</b></p> <ul style="list-style-type: none"> <li>• The recommended temperature for the freezer compartment for normal ice production is 0 °F (-18 °C). If the freezer temperature is warmer, ice production will be affected.</li> </ul>
<p><b>Icemaker is not making ice</b></p>	<p><b>Refrigerator was recently installed or icemaker recently connected.</b></p> <ul style="list-style-type: none"> <li>• It may take up to 24 hours for each compartment to reach the desired temperature for the icemaker to begin making ice.</li> </ul> <p><b>Icemaker is not turned on.</b></p> <ul style="list-style-type: none"> <li>• Locate the icemaker ON/OFF and confirm that it is turned on.</li> </ul> <p><b>The ice detecting sensor is obstructed.</b></p> <ul style="list-style-type: none"> <li>• Foreign substances or frost on the ice-detecting sensor can interrupt ice production. Make sure that the sensor area is clean at all times for proper operation.</li> </ul> <p><b>The refrigerator is not connected to a water supply or the supply shutoff valve is not turned on.</b></p> <ul style="list-style-type: none"> <li>• Connect the refrigerator to the water supply and turn the water shutoff valve fully on.</li> </ul> <p><b>Icemaker shutoff (arm or sensor) obstructed.</b></p> <ul style="list-style-type: none"> <li>• If your icemaker is equipped with an ice shutoff arm, make sure that the arm moves freely. If your icemaker is equipped with the electronic ice shutoff sensor, make sure there is a clear path between the two sensors.</li> </ul>



Problem	Possible Cause & Solution
	<p><b>Reverse osmosis water filtration system is connected to your cold water supply.</b></p> <ul style="list-style-type: none"> <li>Reverse osmosis filtration systems can reduce the water pressure below the minimum amount and result in icemaker issues. (Refer to the Connecting the Water Line section for more information.)</li> </ul>
<p><b>Ice has bad taste or odor.</b></p>	<p><b>Water supply contains minerals such as sulfur.</b></p> <ul style="list-style-type: none"> <li>A water filter may need to be installed to eliminate taste and odor problems. Note that in some cases, a filter may not help. It may not be possible to remove all minerals/odors from the water supply. Taste in all water supplies.</li> </ul>
	<p><b>Icemaker was recently installed.</b></p> <ul style="list-style-type: none"> <li>Ice that has been stored for too long will shrink, become cloudy, and may develop a stale taste. Throw away old ice and make a new supply.</li> </ul>
	<p><b>The food has not been stored properly in either compartment.</b></p> <ul style="list-style-type: none"> <li>Rewrap the food. Odors may migrate to the ice if food is not wrapped properly.</li> </ul>
	<p><b>The interior of the refrigerator needs to be cleaned.</b></p> <ul style="list-style-type: none"> <li>See the Maintenance section for more information.</li> </ul>
	<p><b>The ice storage bin needs to be cleaned.</b></p> <ul style="list-style-type: none"> <li>Empty and wash the bin (discard old cubes). Make sure that the bin is completely dry before reinstalling it.</li> </ul>
<p><b>Icemaker is making too much ice.</b></p>	<p><b>Icemaker shutoff (arm/ sensor) is obstructed.</b></p> <ul style="list-style-type: none"> <li>Empty the ice bin. If your icemaker is equipped with an ice shutoff arm, make sure the arm moves freely. If your icemaker is equipped with the electronic ice shutoff sensor, make sure that there is a clear path between the two sensors. Reinstall the ice bin and wait 24 hours to confirm proper operation.</li> </ul>
<p><b>Ice is not dispensing.</b></p>	<p><b>Unable to hear the sound of ice coming out?</b></p> <ul style="list-style-type: none"> <li>In the control panel, select the modes for cubed ice and crushed ice alternately to dispense the ice.</li> </ul>



Problem	Possible Cause & Solution
	<p><b>Doors are not closed completely.</b></p> <ul style="list-style-type: none"> <li>• Ice will not dispense if any of the refrigerator doors are left open.</li> </ul>
	<p><b>Infrequent use of the dispenser.</b></p> <ul style="list-style-type: none"> <li>• Infrequent use of the ice dispenser will cause the cubes to stick together over time, which will prevent them from properly dispensing. Check the ice bin for ice cubes that are clumping/ sticking together. If they are, break up the ice cubes to allow for proper operation.</li> </ul>
	<p><b>The delivery chute is clogged with frost or ice fragments.</b></p> <ul style="list-style-type: none"> <li>• Eliminate the frost or ice fragments by removing the ice bin and clearing the chute with a plastic utensil. Dispensing cubed ice can also help prevent frost or ice fragment buildup.</li> </ul>
	<p><b>The dispenser display is locked.</b></p> <ul style="list-style-type: none"> <li>• Press and hold the Lock button for three seconds to unlock the control panel and dispenser.</li> </ul>
	<p><b>Ice bin is empty.</b></p> <ul style="list-style-type: none"> <li>• It may take up to 24 hours for each compartment to reach the desired temperature for the icemaker to begin making ice. Make sure that the shutoff (arm/sensor) is not obstructed. Once the ice supply in the bin has been completely exhausted, it may take up to 90 minutes before additional ice is available, and approximately 24 hours to completely refill the bin.</li> </ul>



**Water**



Problem	Possible Cause & Solution
<p><b>Water is dispensing slowly.</b></p>	<p><b>Water filter has been exhausted.</b></p> <ul style="list-style-type: none"> <li>• Replacing the water filter is recommended: <ul style="list-style-type: none"> <li>- Approximately every six months.</li> <li>- When the water filter indicator turns on.</li> <li>- When the water dispenser output decreases.</li> <li>- When the ice cubes are smaller than normal.</li> </ul> </li> </ul>
	<p><b>Reverse osmosis filtration system is used.</b></p> <ul style="list-style-type: none"> <li>• Reverse osmosis filtration systems can reduce the water pressure below the minimum amount and result in icemaker issues. If the problem persists, it may be necessary to contact a plumber.</li> </ul>
	<p><b>Low house water supply pressure.</b></p> <ul style="list-style-type: none"> <li>• The water pressure must be between 20 and 120 psi on models without a water filter and between 40 and 120 psi on models with a water filter. If the problem persists, it may be necessary to contact a plumber.</li> </ul>
<p><b>Water is not dispensing.</b></p>	<p><b>New installation or water line recently connected.</b></p> <ul style="list-style-type: none"> <li>• Dispense 2.5 gallons of water (flush for approximately 5 minutes) to remove trapped air and contaminants from the system. Do not dispense the entire 2.5 gallon amount continuously. Depress and release the dispenser pad for cycles of 30 seconds ON/60 seconds OFF.</li> </ul>
	<p><b>The dispenser panel is locked.</b></p> <ul style="list-style-type: none"> <li>• Press and hold the <b>Lock</b> button for three seconds to unlock the control panel and dispenser.</li> </ul>
	<p><b>The dispenser is not set for water dispensing.</b></p> <ul style="list-style-type: none"> <li>• The dispenser can be set for ice or water. Make certain that the control panel is set for the proper operation. <b>Press</b> the <b>Water</b> button on the control panel to dispense water.</li> </ul>



Problem	Possible Cause & Solution
	<p data-bbox="587 277 1299 309"><b>Refrigerator or freezer doors are not closed properly.</b></p> <ul data-bbox="587 338 1445 369" style="list-style-type: none"> <li>• Water will not dispense if any of the refrigerator doors are left open.</li> </ul> <hr/> <p data-bbox="587 450 1273 481"><b>Water filter has been recently removed or replaced.</b></p> <ul data-bbox="587 510 1596 674" style="list-style-type: none"> <li>• After the water filter is replaced, dispense 2.5 gallons of water (flush for approximately five minutes) to remove trapped air and contaminants from the system. Do not dispense the entire 2.5 gallon amount continuously. Depress and release the dispenser panel for several cycles of 30 seconds ON and 60 seconds OFF.</li> </ul> <hr/> <p data-bbox="587 754 1437 786"><b>Tubing connecting refrigerator to house supply valve is kinked.</b></p> <ul data-bbox="587 815 1596 936" style="list-style-type: none"> <li>• The tubing can kink when the refrigerator is moved during installation or cleaning. Resulting in reduced water flow. Straighten or repair the water supply line and arrange the tubing to prevent future kinks.</li> </ul> <hr/> <p data-bbox="587 1016 1596 1093"><b>The house water supply is not connected, the valve is not turned on fully, or the valve is clogged.</b></p> <ul data-bbox="587 1122 1596 1198" style="list-style-type: none"> <li>• Connect the refrigerator to the water supply and turn the water shutoff valve fully. If the problem persists, it may be necessary to contact a plumber.</li> </ul>
<p data-bbox="252 1263 491 1339"><b>Dispensing warm water.</b></p>	<p data-bbox="587 1272 1059 1303"><b>Refrigerator was recently installed.</b></p> <ul data-bbox="587 1332 1565 1364" style="list-style-type: none"> <li>• Allow 24 hours after installation for the water storage tank to cool completely.</li> </ul> <hr/> <p data-bbox="587 1444 1596 1476"><b>The water dispenser has been used recently and the storage tank was exhausted.</b></p> <ul data-bbox="587 1505 1565 1581" style="list-style-type: none"> <li>• Depending on your specific model, the water storage capacity will range from approximately 20 to 30 oz.</li> </ul> <hr/> <p data-bbox="587 1662 1225 1693"><b>Dispenser has not been used for several hours.</b></p> <ul data-bbox="587 1722 1596 1798" style="list-style-type: none"> <li>• If the dispenser has not been used for several hours, the first glass dispensed may be warm. Discard the first 10oz.</li> </ul> <hr/> <p data-bbox="587 1879 1251 1910"><b>Refrigerator is connected to the hot water supply.</b></p> <ul data-bbox="587 1939 1410 1971" style="list-style-type: none"> <li>• Make sure that the refrigerator is connected to a cold water pipe.</li> </ul>



Problem	Possible Cause & Solution
	<p><b>WARNING: Connecting the refrigerator to a hot water line may damage the icemaker.</b></p>
<p><b>Water has bad taste or odor.</b></p>	<p><b>Water supply contains minerals such as sulfur.</b></p> <ul style="list-style-type: none"> <li>• A water filter may need to be installed to eliminate taste and odor problems.</li> </ul> <hr/> <p><b>Water filter has been exhausted.</b></p> <ul style="list-style-type: none"> <li>• Replacing the water filter is recommended: <ul style="list-style-type: none"> <li>- Approximately every six months.</li> <li>- When the water filter indicator turns on.</li> <li>- When the water dispenser output decreases.</li> <li>- When the ice cubes are smaller than normal.</li> </ul> </li> </ul> <hr/> <p><b>Refrigerator was recently installed.</b></p> <ul style="list-style-type: none"> <li>• Dispense 2.5 gallons of water (flush for approximately 5 minutes) to remove trapped air and contaminants from the system. Do not dispense the entire 2.5 gallon amount continuously. Depress and release the dispenser pad for cycles of 30 seconds ON 60 seconds OFF.</li> </ul>



## Parts & Features



Problem	Possible Cause & Solution
<p><b>Doors will not close correctly or pop open.</b></p>	<p><b>Food packages are blocking the door open.</b></p> <ul style="list-style-type: none"> <li>• Rearrange food containers to clear the door and door shelves.</li> </ul>
	<p><b>Ice bin, crisper cover, pans, shelves, door bins, or baskets are out of position.</b></p> <ul style="list-style-type: none"> <li>• Push bins all the way in and put crisper cover, pans, shelves and baskets into the correct positions. See the Operation section for more information.</li> </ul>
	<p><b>The doors were removed during product installation and not properly replaced.</b></p> <ul style="list-style-type: none"> <li>• Remove and replace the doors according to the Removing and Replacing Refrigerator Handles and Doors section.</li> </ul>
	<p><b>Refrigerator is not leveled properly.</b></p> <ul style="list-style-type: none"> <li>• See Door Alignment in the Refrigeration Installation section to level refrigerator.</li> </ul>
<p><b>Doors are difficult to open.</b></p>	<p><b>The gaskets are dirty or sticky.</b></p> <ul style="list-style-type: none"> <li>• Clean the gaskets and the surfaces that they touch. Rub a thin coat of appliance polish or kitchen wax on the gaskets after cleaning.</li> </ul>
	<p><b>Door was recently closed.</b></p> <ul style="list-style-type: none"> <li>• When you open the door, warmer air enters the refrigerator. As the warm air cools, it can create a vacuum. If the door is hard to open, wait one minute to allow the air pressure to equalize, then see if it opens more easily.</li> </ul>
<p><b>Refrigerator wobbles or seems unstable</b></p>	<p><b>Leveling legs are not adjusted properly.</b></p> <ul style="list-style-type: none"> <li>• Refer to the Leveling and Door Alignment section.</li> </ul>
	<p><b>Floor is not level.</b></p> <ul style="list-style-type: none"> <li>• It may be necessary to add shims under the leveling legs or rollers to complete installation.</li> </ul>



Problem	Possible Cause & Solution
<p><b>Lights do not work.</b></p>	<p><b>LED interior lighting failure.</b></p> <ul style="list-style-type: none"> <li>• The refrigerator compartment lamp is LED interior lighting, and service should be performed by a qualified technician.</li> </ul>
<p><b>Refrigerator has an unusual odor.</b></p>	<p><b>The Air Filter may need to be set to the MAX setting or replaced.</b></p> <ul style="list-style-type: none"> <li>• Set the Air Filter to the MAX setting. If the odor does not go away within 24 hours, the filter may need to be replaced. See the Replacing the Air Filter section for replacement instructions.</li> </ul>
<p><b>The interior of the refrigerator is covered with dust or soot.</b></p>	<p><b>The refrigerator is located near a fire source, such as a fireplace, chimney, or candle.</b></p> <p>Make sure that the refrigerator is not located near a fire source, such as a fireplace, chimney or candle.</p>



## Noises



Problem	Possible Cause & Solution
<b>Clicking</b>	<p><b>The defrost control will click when the automatic defrost cycle begins and the thermostat control (or refrigerator control on some models) will also click when cycling on and off.</b></p> <ul style="list-style-type: none"> <li>• Normal Operation</li> </ul>
<b>Rattling</b>	<p><b>Rattling noises may come from the flow of refrigerant, the water line on the back of the unit, or items stored on top of or around the refrigerator.</b></p> <ul style="list-style-type: none"> <li>• Normal Operation</li> </ul> <p><b>Refrigerator is not resting solidly on the floor.</b></p> <ul style="list-style-type: none"> <li>• Floor is weak or uneven or leveling legs need to be adjusted. See the Leveling and Door Alignment section.</li> </ul> <p><b>Refrigerator with linear compressor was jarred while running.</b></p> <ul style="list-style-type: none"> <li>• Normal Operation</li> </ul>
<b>Whooshing</b>	<p><b>Evaporator fan motor is circulating air through the refrigerator and freezer compartments.</b></p> <ul style="list-style-type: none"> <li>• Normal Operation</li> </ul> <p><b>Air is being forced over the condenser by the condenser fan.</b></p> <ul style="list-style-type: none"> <li>• Normal Operation</li> </ul>
<b>Gurgling</b>	<p><b>Refrigerant flowing through the cooling system.</b></p> <ul style="list-style-type: none"> <li>• Normal Operation</li> </ul>
<b>Popping</b>	<p><b>Contraction and expansion of the inside walls due to changes in temperature.</b></p> <ul style="list-style-type: none"> <li>• Normal Operation</li> </ul>
<b>Sizzling</b>	<p><b>Water dripping on the defrost heater during a defrost cycle.</b></p> <ul style="list-style-type: none"> <li>• Normal Operation</li> </ul>
<b>Vibrating</b>	<p><b>If the side or back of the refrigerator is touching a cabinet or wall, some of the normal vibrations may make an audible sound.</b></p>



Problem	Possible Cause & Solution
	<ul style="list-style-type: none"> <li>• To eliminate the noise, make sure that the sides and back cannot vibrate against wall or cabinet.</li> </ul>
Dripping	<p><b>Water running into the drain pan during the defrost cycle.</b></p> <ul style="list-style-type: none"> <li>• Normal Operation</li> </ul>
Pulsating or high-pitched sound	<p><b>Your refrigerator is designed to run more efficiently to keep your food items at the desired temperature. The high efficiency compressor may cause your new refrigerator to run longer than your old one, but it is still more energy efficient than previous models. While the refrigerator is running, it is normal to hear a pulsating or high-pitched sound.</b></p> <ul style="list-style-type: none"> <li>• Normal Operation</li> </ul>



## Wi-Fi

Problem	Possible Cause & Solution
<b>Trouble connecting appliance and smartphone to Wi-Fi network</b>	<b>The password for the Wi-Fi network was entered incorrectly.</b> <ul style="list-style-type: none"><li>• Delete your home Wi-Fi network and begin the registration process again.</li></ul>
	<b>Mobile data for your smartphone is turned on.</b> <ul style="list-style-type: none"><li>• Turn off the <b>Mobile data</b> on your smartphone before registering the appliance.</li></ul>
	<b>The wireless network name (SSID) is set incorrectly.</b> <ul style="list-style-type: none"><li>• The wireless network name (SSID) should be a combination of English letters and numbers. (Do not use special characters.)</li></ul>
	<b>The router frequency is not 2.4 GHz.</b> <ul style="list-style-type: none"><li>• Only a 2.4 GHz router frequency is supported. Set the wireless router to 2.4 GHz and connect the appliance to the wireless router. To check the router frequency, check with your Internet service provider or the router manufacturer.</li></ul>
	<b>The distance between the appliance and the router is too far.</b> <ul style="list-style-type: none"><li>• If the appliance is too far from the router, the signal may be weak and the connection may not be configured correctly. Move the router closer to the appliance or purchase a Wi-Fi extender and install a Wi-Fi repeater.</li></ul>

### Warning

This content is compiled from multiple sources and is provided for reference purposes only. It may not be complete or fully applicable to all situations. If you are unable to resolve your issue, please contact the product manufacturer or an authorized service provider for official support.