

USING YOUR OVEN

Features

Throughout this manual, features and appearance may vary from your model.

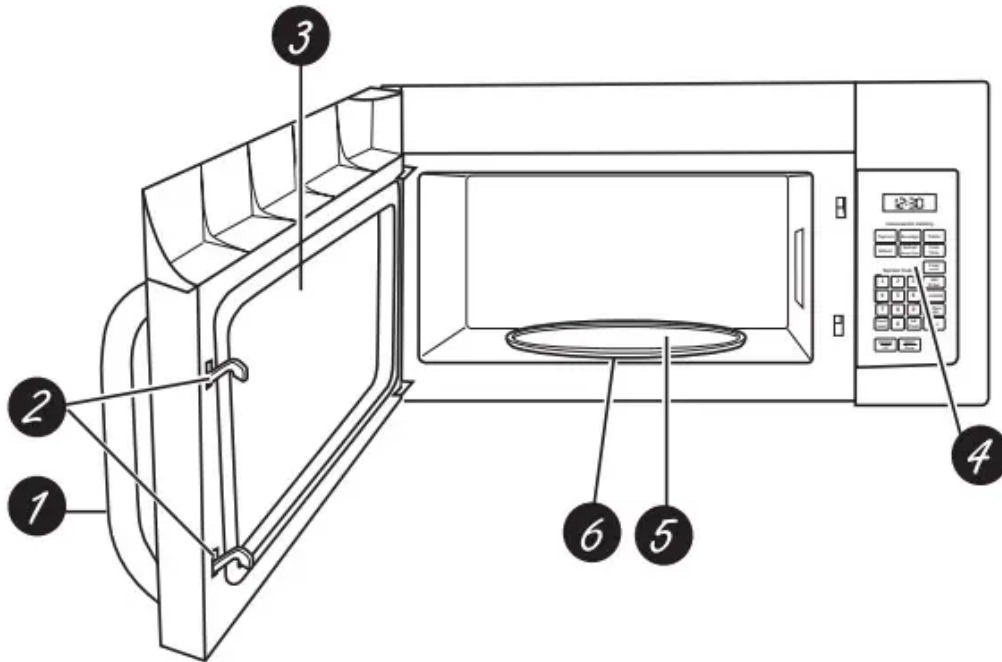

1 Door Latches

2 Window with Metal Shield. Screen allows cooking to be viewed while keeping microwaves confined in the oven.

3 Window with Metal Shield. Screen allows cooking to be viewed while keeping microwaves confined in the oven.

4 Control Panel.

5 Removable Turntable. Turntable and support must be in place when using the oven. The turntable may be removed for cleaning.

6 Removable Turntable Support. The turntable support must be in place when using the oven.

Changing the power level

Changing the Power Level: The power level may be entered or changed before or during cooking. Power Level is set for Level 10 (High) unless it is changed.

1. Press Power Level button.

2. Enter new power level by using the number pads or press the Power Level button multiple times until you find the level you want.
3. After you have selected the power level, wait five seconds. The display will go back to the Cook Time screen.
4. Enter cooking time and press START.

OR

1. Press Cook Time button.
2. Enter your cooking time.
3. Press Power Level button.
4. Enter new power level by using the number pads or press the Power Level button multiple times until you find the level you want.
5. After you have selected the power level, wait five seconds. The display will go back to the Cook Time (Enter Time) screen.
6. Press START

Variable power levels add flexibility to microwave cooking. The power levels on the microwave oven can be compared to the surface units on a range. Each power level gives you microwave energy a certain percent of the time. Power level 7 is microwave energy 70% of the time. Power level 3 is energy 30% of the time. Most cooking will be done on High (power level 10) which gives you 100% power. Power level 10 will cook faster but food may need more frequent stirring, rotating or turning over. A lower setting will cook more evenly and need less stirring or rotating of the food. Some foods may have better flavor, texture or appearance if one of the lower settings is used. Use a lower power level when cooking foods that have a tendency to boil over, such as scalloped potatoes and some casseroles.

Rest periods (when the microwave energy cycles off) give time for the food to “equalize” or transfer heat to the inside of the food. An example of this is shown with Power level 3—the defrost cycle. If microwave energy did not cycle off, the outside of the food would cook before the inside was defrosted.

Here are some examples of uses for various power levels:

- High 10 (100%): Fish, bacon, vegetables, boiling liquids.
- Med-High 7 (70%): Gentle cooking of meat and poultry; baking casseroles and reheating.
- Medium 5 (50%): Slow cooking and tenderizing for stews and less tender cuts of meat.
- Low 2 or 3 (20 or 30%): Defrosting; simmering; delicate sauces.
- Warm 1 (10%): Keeping food warm; softening butter.
- NOTE: You can also change the power level during many cooking modes by pressing the power level button entering a valid power level.

About the features

Cook Time

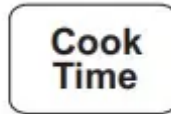

- Allows you to microwave from 1 second to 99 minutes and 99 seconds.
- Power level 10 (HIGH) is automatically set, but you may change it for more flexibility.
 1. Press Cook Time.
 2. Enter cooking time.
 3. Press START. Cooking will start when the countdown begins in the display.
- You may open the door during Cook Time to check the food. Close the door and press START to resume cooking

Express Cook

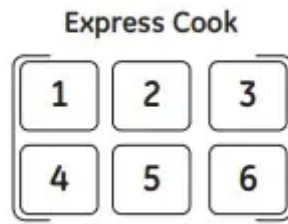

- This is a quick way to set cooking time from 1-6 minutes.
 1. Press one of the Express Cook pads (from 1-6) for 1-6 minutes of cooking at power level 10. For example, press the 2 pad for 2 minutes of cooking time.
- The power level can be changed as time is counting down. Press POWER LEVEL and enter 1-10.
- NOTE: Express Cook function pertains to pads 1-6 only.

Add 30 Sec

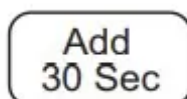

- It will add 30 seconds to the time counting down each time the pad is pressed. Each touch will add 30 seconds, up to 99 minutes and 99 seconds.

- Add 30 sec can also be used like an express 30 seconds button. The microwave oven will start immediately when pressed.

Popcorn



Use only with prepackaged
microwave popcorn weighing
2.5 to 3.0 ounces.

- To use the Popcorn feature:
 1. Press the POPCORN button once for 2.0 ounce bag, twice for 2.5 ounce bag, or three times for a 3.0 ounce bag.
 2. Press START. Cooking will start when the countdown begins in the display. You can not change the selection or quantity after the feature has started.
- IMPORTANT: Do not use the sensor features twice in succession on the same food portion. If food is undercooked after the first countdown, use Cook Time for additional time.
- If food is undercooked after the countdown, use Cook Time for additional cooking time. We recommend 30 seconds and watch carefully.

Reheat

- The Reheat feature reheats servings of previously cooked foods or a plate of leftovers.
- Place the cup of liquid or covered food in the oven.
 1. Press the REHEAT button up to six times to choose the correct selection. Press once for a pizza. Press twice for vegetables. Press three times for a plate of leftovers. Press four times for soup. Press five times for meat. Press six times for pasta.
 2. Press the reheat pad again after food type has been entered in order to select quantity.
 3. Press START.
- Cooking will start when the countdown begins in the display.

Reheat

- After removing food from the oven, stir, if possible, to even out the temperature. Reheated foods may have wide variations in temperature. Some areas of food may be extremely hot.
- If food is not hot enough after the countdown use Cook Time for additional reheating time.
- Some Foods Not Recommended for Use With Reheat
- It is best to use Cook Time for these foods:
 - Bread products.
 - Foods that must be reheated uncovered.
 - Foods that need to be stirred or rotated.
 - Foods calling for a dry look or crisp surface after reheating.
- NOTE: Do not use this feature twice in succession on the same food portion—it may result in severely overcooked or burnt food.

Beverage

Use the Beverage feature to heat various amounts of liquids measured in ounces: Place the liquid into the microwave oven.

4 oz.	1/2 cup
8 oz.	1 cup
12 oz.	1-1/2 cups
16 oz.	2 cups

1. Press the Beverage button up to four times to choose the correct selection. Press once for a 4 ounce beverage. Press twice for a 8 ounce beverage. Press three times for a 12 ounce beverage. Press four times for a 16 ounce beverage.
2. Press START. Cooking will start when the countdown begins in the display

Beverage

Potato

To use the Potato feature: Place the potato(es) into the oven

1. Press the Potato button up to four times to choose the correct selection. Press once for 1 item. Press twice for 2 items. Press three times for 3 items. Press four times for 4 items.
2. Press START.

Cooking will start when the countdown begins in the display.

NOTE: Do not use this feature twice in succession on the same food portion. It may result in severely overcooked or burnt food.



Defrosting

Weight Defrost



Use Weight Defrost for meat, poultry and fish. Use Time Defrost for most other frozen foods. (Time Defrost is explained on page 13.)

1. Press DEFROST once for Weight Defrost.
2. Enter the weight in pounds.
3. Press START. Cooking will start when the countdown begins in the display.

Defrosting Tips

- Remove meat from package and place on microwavesafe dish.
- When the oven signals, turn the food over. Remove defrosted meat or shield warm areas with small pieces of foil.
- After defrosting, most meats need to stand 5 minutes to complete defrosting. Large roasts should stand for about 30 minutes.

Conversion Guide

If the weight of food is stated in pounds and ounces, the ounces must be converted to tenths (.1) of a pound.

Ounces	Pounds
1-2	.1
3	.2
4-5	.3
6	.4
7-8	.5
9-10	.6
11	.7
12-13	.8
14-15	.9

Time Defrost

Allows you to defrost for a selected length of time. See the Defrosting Guide on page 14 for



suggested times (Weight Defrost is explained on page 12).

1. Press DEFROST twice for Time Defrost.
2. Enter defrosting time in minutes and seconds.
3. Press START. Cooking will start when the countdown begins in the display. At one half of selected defrosting time, turn food over and break apart or rearrange pieces for more even defrosting. Shield any warm areas with small pieces of foil. The oven will continue to defrost if you don't open the door and turn the food. Noises may be heard during defrosting. This is normal when oven is not operating at High power.

Defrosting Tips

- Foods frozen in paper or plastic can be defrosted in the package. Closed packages should be slit, pierced or vented AFTER food has partially defrosted. Plastic storage containers should be partially uncovered.
- Family-size, prepackaged frozen dinners can be defrosted and microwaved. If the food is in a foil container, transfer it to a microwave-safe dish.
- Foods that spoil easily should not be allowed to sit out for more than one hour after defrosting. Room temperature promotes the growth of harmful bacteria.

- For more even defrosting of larger foods, such as roasts, use Time Defrost. Be sure large meats are completely defrosted before cooking.
- When defrosted, food should be cool but softened in all areas. If still slightly icy, return to the microwave very briefly, or let it stand a few minutes.

About the other features

Clock



To change the time of day.

1. Press the Set Clock button. (The microwave should not be running.)
2. Enter the appropriate time of day. Clock is on a 12-hour scale.
3. Press Set Clock or Start to accept the time.

Pause

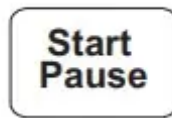

- In addition to starting many functions, START/PAUSE allows you to stop cooking without opening the door or clearing the display and resume cooking later.

Child Lock-Out



- Press the CANCEL/OFF button to stop and cancel cooking at any time

Control Lock-Out



- You may lock the control panel to prevent the oven from being accidentally started during cleaning or being used by children.

- To lock or unlock the controls, press and hold the CANCEL/ OFF button for three seconds. When the control panel is locked, LOCKED will be displayed briefly anytime a button or dial is pressed. “L” will show in the display.

Surface Light

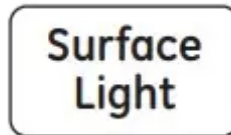

- Press SURFACE LIGHT once for bright light, twice for the night light or a third time to turn the light off.

Timer



- NOTE: The Timer indicator will be lit while the timer is operating.
- Timer: The Timer operates as a minute timer and can be used at any time, even when the oven is operating.
 1. Press the Timer button.
 2. Enter a time.
 3. Press the Timer 3 Start button to start.
- To cancel, press the Timer button or Cancel button.
- NOTE: If you press the Cancel button to cancel the timer and you are cooking at the same time, it will cancel your cooking selection also. When time is up, the oven will signal. To turn off the timer signal, press Timer or Cancel

Display

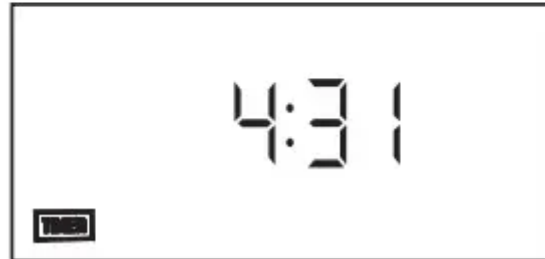

- If you have the Timer counting down and you are using the Cook Time at the same time, you can change the display to show either the timer or the cook time countdown.
- If the display shows the time for the Timer and you would like to view the Cook Time, press the COOK TIME button.
- If the display shows the time for the Cook Time and you would like to view the Timer, press the TIMER button

Turntable



- For best cooking results, leave the turntable on. It can be turned off for large dishes.
- Press the Turntable pad once to turn the turntable off. Press again to turn the turntable back on.
- Sometimes the turntable can become too hot to touch. Be careful touching the turntable during and after cooking.
- Turntable can be turned off during the Cook Time or Express Cook features by pressing the Turntable pad. Note: At the conclusion of the Cook Time and Express Cook features, the turntable will automatically return to ON.

Vent Fan

Vent Fan

- The vent fan removes steam and other vapors from surface cooking.
- Press Vent Fan once for high fan speed, twice for low fan speed or three times to turn the fan off.

Automatic Fan

- An automatic fan feature protects the microwave from too much heat rising from the cooktop below it. It automatically turns on if it senses too much heat.
- If you have turned the fan on you may find that you cannot turn it off. The fan will automatically turn off when the internal parts are cool. It may stay on for 30 minutes or more after the cooktop and microwave controls are turned off.

Insert Food Reminder

- A reminder will show on the display if the user tries to start the cooking cycle without placing food inside the microwave oven within 5 minutes prior to starting the cooking cycle.

Cooking Complete Reminder

- To remind you that you have food in the oven, the oven will display “Food is ready” and beep once a minute until you either open the oven door or press the CANCEL/OFF button.

Care and Cleaning

Helpful Hints



- An occasional thorough wiping with a solution of baking soda and water keeps the inside fresh.
- Unplug the cord before cleaning any part of this oven.

How to Clean the Inside

Walls, Floor, Inside Window, Metal and Plastic Parts on the Door

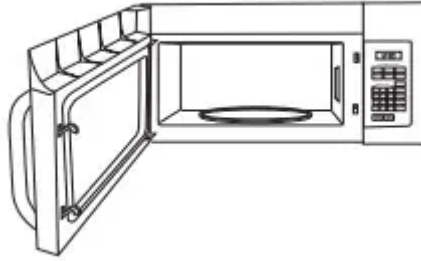

- Some spatters can be removed with a paper towel; others may require a damp cloth. Remove greasy spatters with a sudsy cloth, then rinse with a damp cloth. Do not use abrasive cleaners or sharp utensils on oven walls.
- Never use a commercial oven cleaner on any part of your microwave.

Removable Turntable and Turntable Support

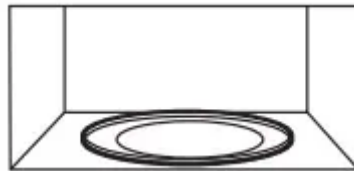

- To prevent breakage, do not place the turntable into water just after cooking. Wash it carefully in warm, sudsy water or in the dishwasher. The turntable and support can be broken if dropped. Remember, do not operate the oven in the microwave mode without the turntable and support seated and in place.

How to Clean the Outside

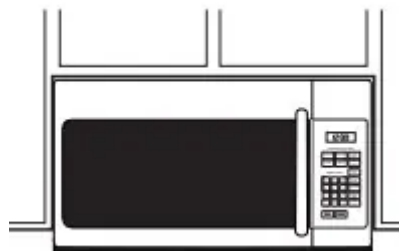

- We recommend against the use of spray cleaners and using cleaners with ammonia or alcohol, as they can damage the appearance of the microwave oven. If you choose to use a common household cleaner, first apply the cleaner directly to a clean cloth, then wipe the soiled area.
- Case: Clean the outside of the microwave with a sudsy cloth. Rinse and then dry. Wipe the window clean with a damp cloth.

- Control Panel: Wipe with a damp cloth. Dry thoroughly. Do not use cleaning sprays, large amounts of soap and water, abrasives or sharp objects on the panel—they can damage it. Some paper towels can also scratch the control panel.
- Door Panel: Before cleaning the front door panel, make sure you know what type of panel you have. Refer to the eighth digit of the model number. “S” is stainless steel “B”, “W” or “C” are plastic colors.
- Stainless Steel (on some models): The stainless steel panel can be cleaned with Stainless Steel Magic or a similar product using a clean, soft cloth. Apply stainless cleaner carefully to avoid the surrounding plastic parts. Do not use appliance wax, polish, bleach or products containing chlorine on Stainless Steel finishes.
- Plastic Color Panels: Use a clean, soft, lightly dampened cloth, then dry thoroughly.
- Door Seal: It’s important to keep the area clean where the door seals against the microwave. Use only mild, non-abrasive detergents applied with a clean sponge or soft cloth. Rinse well.
- Bottom: Clean off the grease and dust on the bottom often. Use a solution of warm water and detergent.

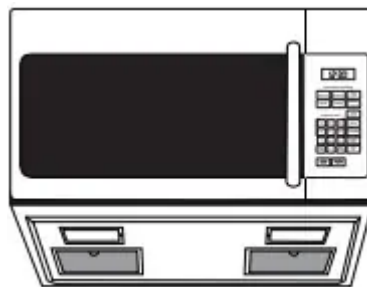

Removing and Cleaning the Filters

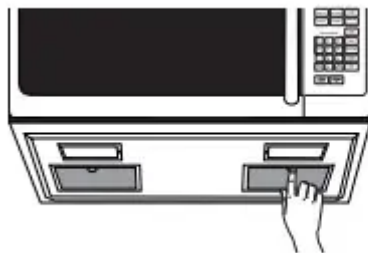

- To remove, slide them to the rear using the tabs. Pull down and out.
- To clean the vent filters, soak them and then swish around in hot water and detergent. Don’t use ammonia or ammonia products because they will darken the metal. Light brushing can be used to remove embedded dirt.
- Rinse, shake and let dry before replacing.

- To replace, slide the filters into the frame slots on the back of each opening. Press up and to the front to lock into place.

Charcoal Filter

- The charcoal filter cannot be cleaned. It must be replaced. Order Part No. WB02X11550 from your GE supplier. If the model is not vented to the outside, the air will be recirculated through a disposable charcoal filter that helps remove smoke and odors.
- The charcoal filter should be replaced when it is noticeably dirty or discolored (usually after 6 to 12 months, depending on usage).

To Remove the Charcoal Filter

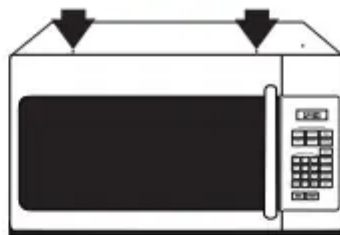

Remove 2 grille screws to
remove the grille.

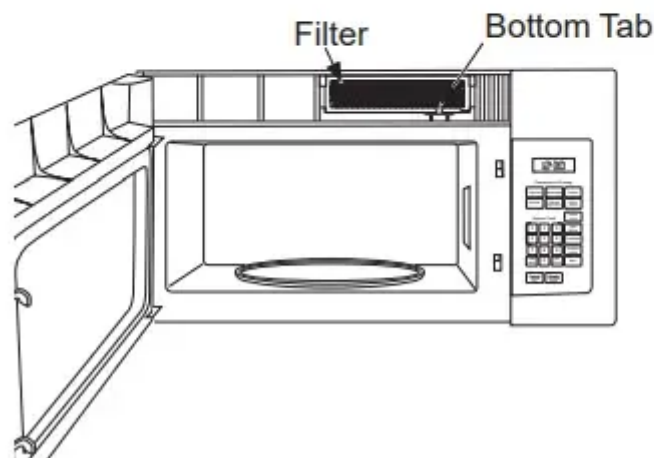

- To remove the charcoal filter, first disconnect power at the main fuse or circuit breaker, or pull the plug. Remove the top grille by removing only the two screws that hold it in place, as shown.
- You may need to open the cabinet doors to remove the screws.
- Press back on the top of the filter with both hands until the filter lays down almost horizontal. Lift the filter at the bottom until it comes free of the tabs. Slide the filter down and out.

Replacing the Oven Cavity Lamp

1. Disconnect power at the main fuse or circuit breaker panel.

2. Remove the top grill by removing the two screws that hold it in place.
3. Remove charcoal filter if present. NOTE: Charcoal filter is an optional kit, you may not have one.
4. Press the retainer holding the lamp shield in place.
5. Pull the lamp shield out. Unscrew the light bulb out and replace with the 120V-130V, 30W incandescent bulb. Order WB25X10029 from your GE supplier.
6. Return the lamp and lamp shield to original position and replace charcoal filter.
7. Replace the grill and 2 screws. Reconnect power to the oven.

Cooktop Lights/Nite Lights

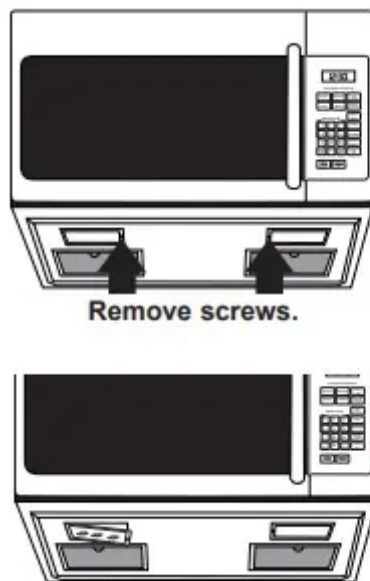

Replace with 120 volt, 40 watt (max) incandescent bulbs. Order WB25X10030 from your GE supplier.

1. To replace the cooktop lights/nite lights, first disconnect the power at the main fuse or circuit breaker panel, or pull the plug.
2. One side at a time, remove the screw from the side of the light compartment cover and lower the cover until it stops.
3. Be sure the bulb is cool before removing. Break the adhesive seal by gently unscrewing the bulb.
4. Screw in the new bulb, then raise the light cover and replace the screw. Repeat for the other light. Connect electrical power to the oven.

Vent Fan

- The vent fan has two metal reusable vent filters. Models that recirculate air back into the room also use a charcoal filter.

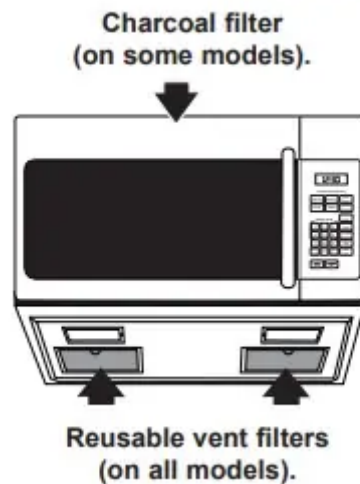

Reusable Vent Filters

- The metal filters trap grease released by foods on the cooktop. They also prevent flames from foods on the cooktop from damaging the inside of the oven.
- For this reason, the filters must always be in place when the hood is used. The vent filters should be cleaned once a month, or as needed.

To Install the Charcoal Filter

- To install a new charcoal filter, remove plastic and other outer wrapping from the new filter.
- Insert the top of the filter up and into the grooves on both sides of the inside of the top opening. Once you have cleared the bottom tab, push the bottom of the filter in until it rests in place vertically behind the tab

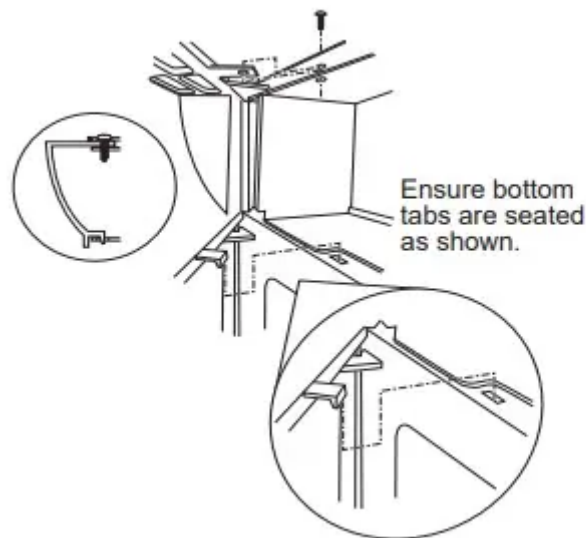

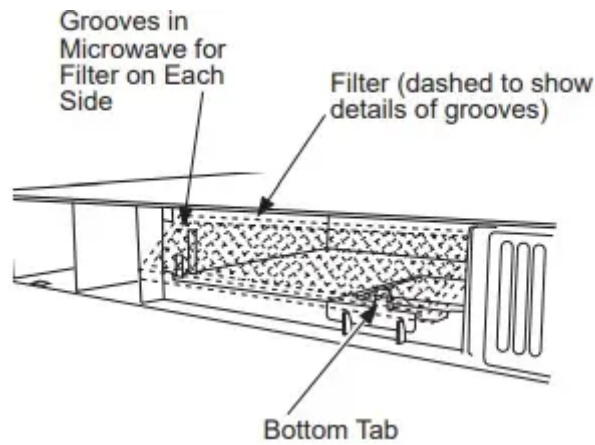

TROUBLESHOOTING TIPS

Microwave Terms

Term	Definition
Arcing	<p>Arcing is the microwave term for sparks in the oven. Arcing is caused by:</p> <ul style="list-style-type: none"> • metal or foil touching the side of the oven. • foil that is not molded to food (upturned edges act like antennas). • metal such as twist-ties, poultry pins, gold-rimmed dishes. • recycled paper towels containing small metal pieces. • plates or dishes with a metallic trim or glaze with a metallic sheen.
Covering	<p>Covers hold in moisture, allow for more even heating and reduce cooking time. Venting plastic wrap or covering with wax paper allows excess steam to escape</p>
Shielding	<p>In a regular oven, you shield chicken breasts or baked foods to prevent over-browning. When microwaving, you use small strips of foil to shield thin parts, such as the tips of wings and legs on poultry, which would cook before larger parts</p>
Standing Time	<p>When you cook with regular ovens, foods such as roasts or cakes are allowed to stand to finish cooking or to set. Standing time is especially important in microwave cooking. Note that a microwaved cake is not placed on a cooling rack</p>
Venting	<p>After covering a dish with plastic wrap, you vent the plastic wrap by turning back one corner so excess steam can escape</p>

Problem	Possible Cause	What To Do
Oven will not start	<p>A fuse in your home may be blown or the circuit breaker tripped.</p> <p>Power surge.</p> <p>Plug not fully inserted into wall outlet</p> <p>Door not securely closed.</p>	<p>Replace fuse or reset circuit breaker.</p> <p>Unplug the microwave oven, then plug it back in</p> <p>Make sure the 3-prong plug on the oven is fully inserted into wall outlet.</p> <p>Open the door and close securely</p>
Control panel lighted, yet oven will not start	<p>Door not securely closed.</p> <p>START/PAUSE button not pressed after entering cooking selection</p> <p>Another selection entered already in oven and CANCEL/OFF button not pressed to cancel it</p> <p>Cooking time not entered after pressing COOK TIME</p> <p>CANCEL/OFF was pressed accidentally.</p>	<p>Open the door and close securely</p> <p>Press START/PAUSE.</p> <p>Press CANCEL/OFF.</p> <p>Make sure you have entered cooking time after pressing COOK TIME.</p> <p>Reset cooking program and press START/PAUSE.</p>
CONTROL LOCKED appears on display	The control has been locked	Press and hold CANCEL/OFF for about 3 seconds to unlock the control.
Floor of the oven is warm even when the oven has not been used	The cooktop light is located below the oven floor. When light is on, the heat it produces may make the oven floor get warm.	This is normal.
You hear an unusual low-tone beep	You have tried to change the power level when it is not allowed	Many of the oven's features are preset and cannot be changed.
Vent fan comes on automatically	The vent fan automatically turns on to protect the microwave if it senses too	This is normal.

	much heat rising from the cooktop below	
--	--	--

Things That Are Normal With Your Microwave Oven

- Moisture on the oven door and walls while cooking. Wipe the moisture off with a paper towel or soft cloth.
- Moisture between the oven door panels when cooking certain foods. Moisture should dissipate shortly after cooking is finished.
- Steam or vapor escaping from around the door.
- Light reflection around door or outer case.
- Dimming oven light and change in the blower sound at power levels other than high.
- Noises while oven is operating.
- TV/radio interference might be noticed while using the microwave. Similar to the interference caused by other small appliances, it does not indicate a problem with the microwave. Plug the microwave into a different electrical circuit, move the radio or TV as far away from the microwave as possible, or check the position and signal of the TV/ radio antenna.

Warning

This content is compiled from multiple sources and is provided for reference purposes only. It may not be complete or fully applicable to all situations. If you are unable to resolve your issue, please contact the product manufacturer or an authorized service provider for official support.