

Connections and Setup

Remote Control Functions

Most of your television's functions are available via the menus that appear on the screen. The remote control supplied with your set can be used to navigate through the menus and to configure all the general settings.

Note: figures and illustrations in this operation manual are provided for reference only and may differ from actual product appearance. Certain function may not be available for some models, e.g. GUIDE/SUBTITLE functions are only available under DTV source. And DTV is not available for certain model.



RC802N

- To switch the sound off and back on.
- Standby / quit standby.
- Numeric buttons** To enter channel numbers or a digit.
- To access T recommended apps.
- LIST** To display the channel list.
- To control the volume.
- To display programme information, if available.
- To display the Settings menu.
- P** To change channels.
- To access the Smart TV homepage.
- To display the Option menu.
- ▲/▼/◀/▶** Navigation direction buttons.
- OK** To confirm an entry or selection.
- To return to the previous menu or quit an app.
- To select input source.
- EXIT** To exit the Settings menu.
- LANG** To select an audio language available for selected digital TV programme.
- GUIDE** To toggle the Electronic Programme Guide on or off. *(only available for digital channels.)*
- TEXT** To toggle Teletext on or off.
- SUBT.** To select a subtitle language available for selected digital TV programme.
- Colour buttons** To select tasks or Teletext pages; to be used for HbbTV function.
 - To start fast reverse.
 - To pause playback.
 - To start fast forward.
 - To record programmes under DTV source.
 - To start playback.
 - To stop playback.
 - NETFLIX** To access the NETFLIX application. *(Not available for some models.)*

Installing Batteries



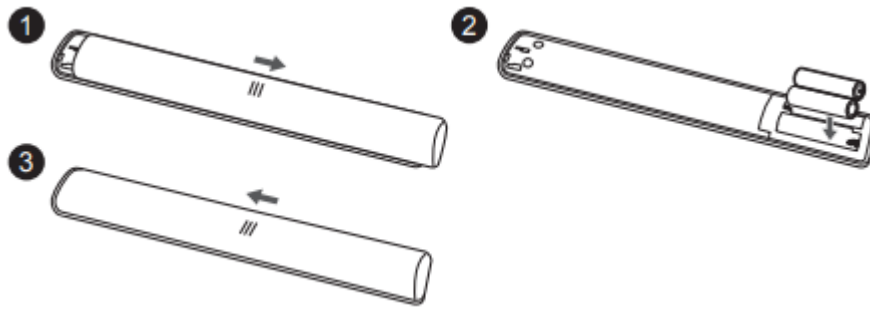









1. Push to open the back cover as illustrated.
2. Insert two AAA batteries according to the polarities marked on the battery case.
3. Replace the back cover as illustrated.



Exclusive Remote Control



RC802V

	Standby / quit standby..
	To display the Settings menu.
	To access the Smart TV homepage.
	To display the Option menu.
	Navigation direction buttons. The ▲/▼ buttons are also used to change channels in TV mode.
OK	To confirm an entry or selection. The button is also used to display the channel list in TV mode.
	To return to the previous menu or quit an app.
	To select input source.
	Press the Assistant button on your remote to talk to the Google Assistant. <i>(Available only when the network connection works normally.)</i>
	To pop up the virtual remote control keyboard when available.
	To control the volume.
	To change channels.
NETFLIX	To access Netflix. <i>(Not available for some models.)</i>
	To access T recommended apps.

Google and Android TV are trademarks of Google LLC.

How to Use the Remote Control

When using the Google Assistant button for the first time, you will be prompted to pair the remote with the TV.

- Keep the remote control and TV in 1 meter, please follow the on-screen guide for pairing instructions. You can use the Google Assistant button after activating successfully.
- The Google Assistant is only available for content search from certain apps.
- Set languages in the settings to your local language or official language to enhance voice search successfully

Installing Batteries

1. Push to open the back cover as illustrated.
2. Insert two AAA batteries according to the polarities marked on the battery case.
3. Replace the back cover as illustrated.

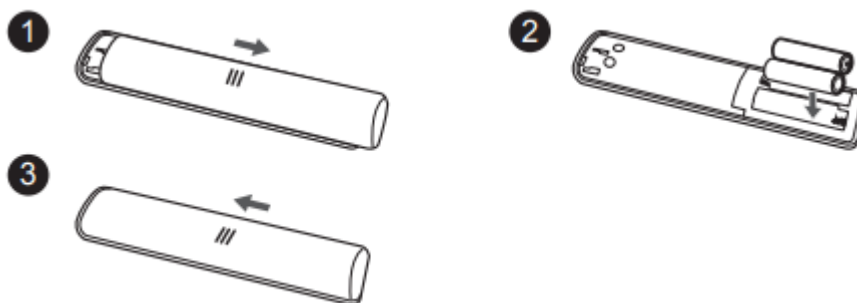

Network Connection

Your TV will require an internet connection to operate all functions. Data usage charges may apply. Please refer to your Internet Service Provider (ISP) for additional information.

To access the internet, you must subscribe to high speed broadband internet service from your internet service provider.

Your TV can be connected to your home network in two ways:

- Wired, using the RJ45 (LAN) connector on the back panel.
- Wireless, using the internal wireless or external wireless USB adapter and your home wireless network.

Note: the following instructions are just the usual ways to connect your TV to the wired or wireless network. The connection method may be different depending on your actual network configuration. If you have any questions about your home network, please refer to your ISP(Internet Service Provider).

Connecting to a wired Network

To connect to a wired network:

1. Ensure you have:
 - An Ethernet cable long enough to reach your TV
 - A router or modem with an available Ethernet port.
 - A high-speed internet connection.
 - An Ethernet (LAN) port on the back of the TV.
2. Connect your Ethernet cable to the router and to the Ethernet port on the back of the TV.
3. Use the Network & Internet menu to configure the TV.

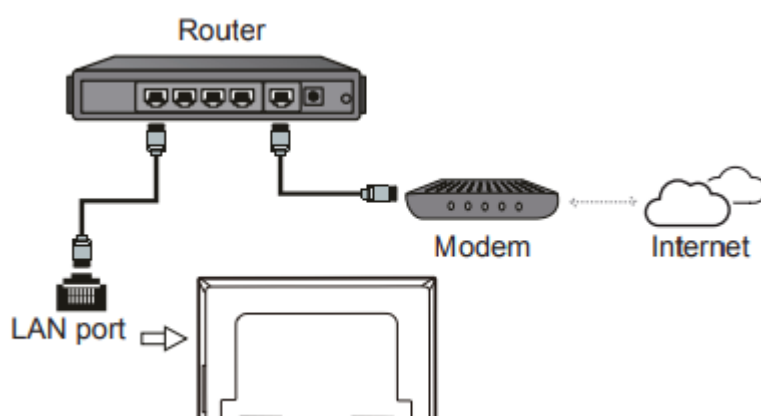

Connecting to a Wireless Network

To connect to a wireless network



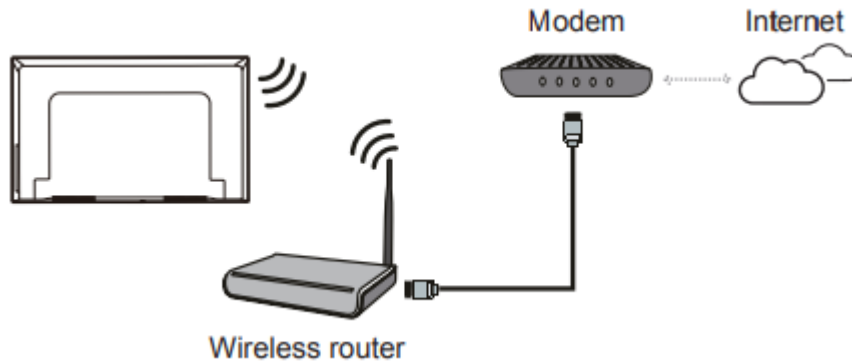

1. Ensure you have:

- A router broadcasting a high-speed wireless signal
- A high-speed internet connection

2. Use the Network & Internet menu to configure the TV.



Note: please follow below steps to enter the Network & Internet menu.



1. Press  on the remote control to display the Smart TV homepage.
2. Press  to move the cursor to  (Settings) on the right top of the screen and press OK to enter.
3. Press  to select Network & Internet, then press OK to enter the submenu and follow the on-screen guidance to set up your network.

Basic TV Operations



Accessing Channels

- Using the RC802N Remote Control

Using the numeric buttons: press the corresponding numeric buttons on the remote control to access the channels.



Using the P  buttons: press the P  buttons on the remote control to scroll through the channels. Using the LIST button: press the LIST button to display the channel list and press  and OK to select channels

- Using the RC802V Remote Control



Using the  buttons: press the  buttons on the remote control to scroll through the channels.







Using the OK button: press the OK button to display the channel list and press  and OK to select channels.

Using the P +/- buttons: press the P +/- buttons on the remote control to scroll through the channels.

Using the  button: press  to display the virtual remote control keyboard, then you can use the numeric buttons or the LIST button to operate accordingly.



Watching Connected Devices

Press  on the remote control to display the source list. Press / to select TV or other input sources and press OK to confirm.

You can also press  on the remote control to display the homepage, press // to move the cursor to the  (Inputs) area on the right top of the screen, and press OK to enter. Then press / and OK to select the input source.

Adjusting Volume

Volume control: press the  buttons on the remote control or the corresponding buttons on the TV set to increase or decrease the volume.

Sound mute: press the  button to temporarily mute the sound. Press this button again or the  button to restore the sound. (Available for RC802N remote control only.)

Accessing Smart TV Homepage



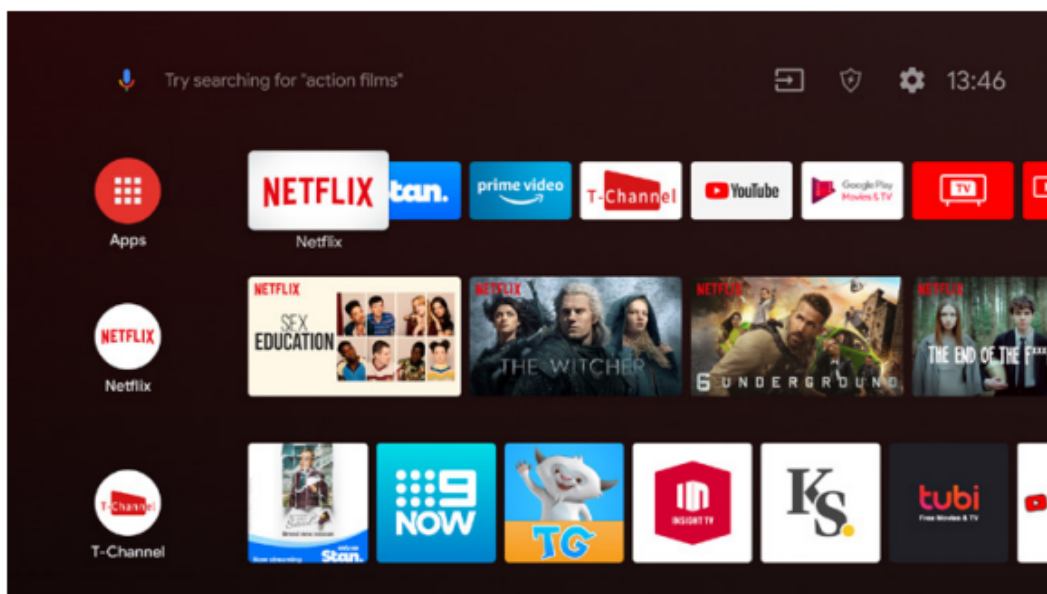



Allows you to enjoy Internet Applications (Apps) and specially adapted Internet websites, and perform system settings for your TV. You can make controlling with the TV remote control.



WARNING:

- Configure the network settings before using Smart TV applications.
- Slow responses and/or interruptions may occur, depending on your network conditions.

- If you experience a problem using an application, please contact the content provider.
- According to circumstances of the content provider, an application's updates or the application itself may be discontinued.
- Depending on your country's regulations, some applications may have limited service or not be supported.
- Changes in application content may be made without prior notice by the service provider.





1. Press  on the remote control to display the Smart TV homepage.
2. Press  and OK to enter the desired apps, functions or settings.
3. Press  to return to the homepage.
4. To exit the homepage, press  to move the cursor to the  (Inputs) area on the right top of the screen, press OK to enter and then press  and OK to select your desired input source.

Note: since the connection with Internet takes time, it's recommended that you wait a few minutes to use the Smart TV feature after activation of TV from standby.

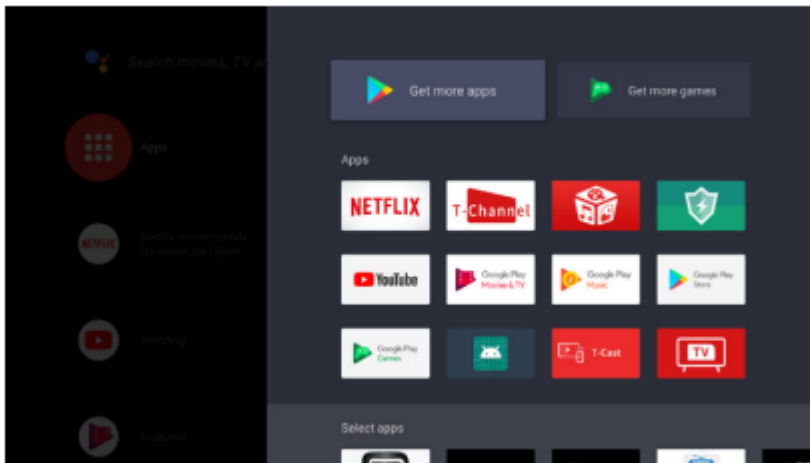
Accessing Google Play

Google Play is your entertainment unbound. It brings together all of the entertainment you love and helps you explore it in new ways, anytime, anywhere. We've brought the magic of Google to music, movies, TV, books, magazines, apps and games, so you get more from your content every day.







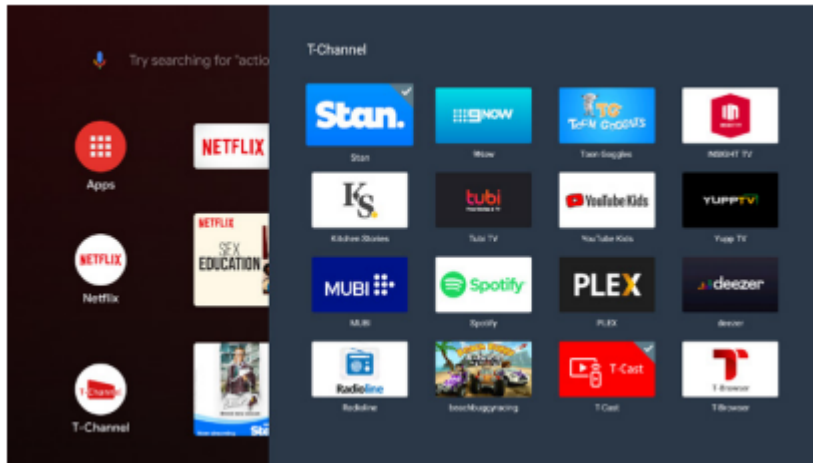

1. Press  on the remote control to display the Smart TV homepage.
2. Press  to select the Apps, and press OK to enter. Then press  and OK to enter the desired apps.
3. Press  to return to the homepage.

Accessing T-Channel

Allows you to enjoy Internet Applications (Apps).









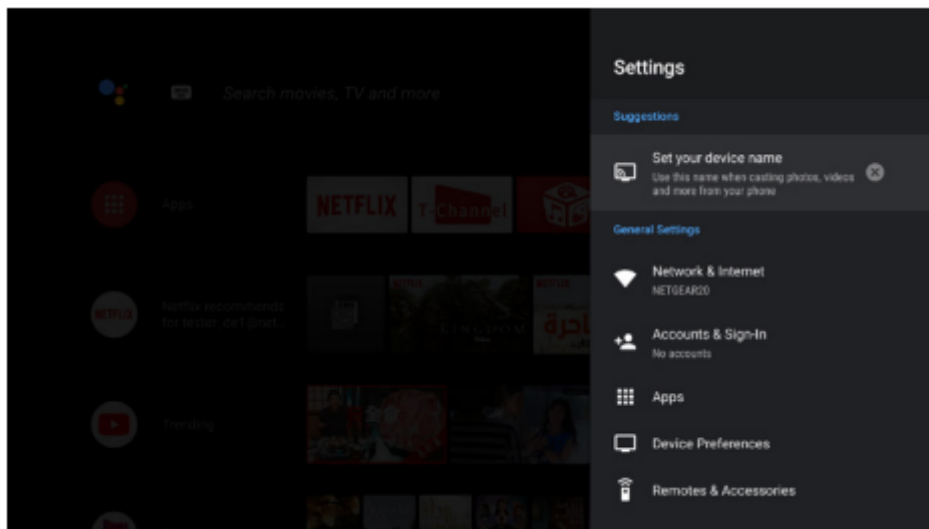

1. Press  on the remote control to display the recommended apps.
2. Press /// and OK to enter the desired apps. For the first time, the apps will be downloaded automatically.
3. Press  to return to the recommend page and exit.

Using System Settings menu

Allows you to not only adjust device settings, such as Network & Internet, Accounts & Sign-In, Apps and Device Preferences, etc., but also set preferences.









1. Press  on the remote control to display the Smart TV homepage.
2. Press /// to move the cursor to  (Settings) on the right top of the screen and press OK to enter the system settings.
3. Press / to choose the items and press OK to enter.
4. Press  to return to previous interface.

5. Press EXIT to close the menu.

Using Instant Power On







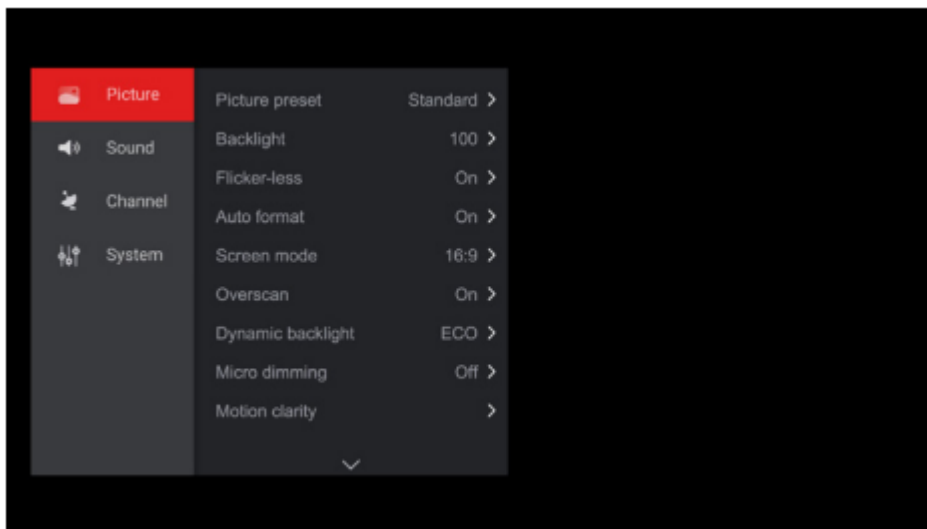

It enables you to turn on your TV faster from standby mode than turning this function off, but it will also increase standby power consumption.

1. Press  on the remote control to display the homepage, Press // to select  (Settings) > Device Preferences > Power > Instant power on and press OK to toggle between On and Off.
2. Press  to return to previous interface.

Using TV Options menu

Allows you to adjust TV settings, such as picture and sound.



1. Press  on the remote control to display the Settings menu.
2. Press / to select the desired item, then press OK/ to enter the corresponding submenu.
3. In submenus, press / to select menu options, then press OK/ to enter the option list, the adjustment interface, or the corresponding submenu.
4. Press  to return to the previous menu.
5. Press EXIT or  to close the menu.

Notes:



- You can also press on the remote control, select Settings (if available) and press OK to enter the Settings menu. Some options may not be available for certain signal sources.
- Setting LED Motion clear on will make fast moving images clearer by controlling the LED backlight, but the picture will be darker and more flickering than with LED Motion clear off.

Using more of your TV

Installing Channels

This section describes how to search and store channels automatically. This may be done in any of the cases below:

- you are prompted that there are no channels in TV mode;
- you want to update your channels.

1. In TV mode, press  on the remote control and select Channel > Channel scan. Press OK/▶ to enter.
2. The TV installs and arranges channels according to your country or region. Press ▲/▼ to select Country/Region, and press OK/▶ to enter. Enter the default password 1234 or your own password in case you have changed the password in the System > Lock menu. Press ▲/▼ to select your country or region and press OK to confirm.
3. Press ▲/▼ to select Automatic search and press OK/▶ to enter.
4. Press ▲/▼ to select Channel type and press ◀/▶ to select Digital, Analogue or Digital&Analogue.
5. After configuration is completed, press ▼ to select Search and press OK to start scanning channels.
6. The channel search may take a few minutes. After the automatic search, channels are arranged in a preset order. If you wish to hide or move channels, press  on the remote control, select Channel > Channel organizer and press OK/▶ to enter.

Note: If the channel search retrieved only the analogue channels it could be caused by poor broadcasting and therefore is not covered by manufacturer warranty. Manufacturers cannot be held responsible for lack of or poor broadcasting in some areas.

Using Subtitles

You can enable subtitles for each TV channel. Subtitles are broadcast via Teletext or DVB-T digital broadcasts. With digital broadcasts, you have the additional option of selecting a preferred subtitle language.



Note: some options are available only when Subtitle is set to On.

Turning On/Off Subtitles

1. Press  on the remote control, select Channel > Subtitle and press OK/▶ to enter.
2. Select the Subtitle option, press OK/▶ to enter, press ▲/▼ to select On or Off and press OK to confirm.



3. Press EXIT or  to close the menu.

Enabling Subtitle Languages on digital TV Channels

1. Press  on the remote control, select Channel > Subtitle > Digital subtitle language 1st and press OK/▶ to enter.
2. Press ▲/▼ to select a subtitle language as your preferred language and press OK to confirm.
3. Press ▲/▼ to select Digital subtitle language 2nd and press OK/▶ to enter.
4. Press ▲/▼ to select a secondary subtitle language and press OK to confirm.
5. Press EXIT or  to close the menu.



Shortcut operation: Press SUBT. on the remote control to directly select a subtitle language available for the selected digital TV programme. (Available for RC802N remote control only.)

Selecting a Subtitle Type on Digital TV Channels

1. Press  on the remote control, select Channel > Subtitle > Subtitle type and press OK/▶ to enter.
2. Press ▲/▼ to select a subtitle type and press OK to confirm. You can select Hearing impaired to display the hearing impaired subtitles with your selected language.
3. Press EXIT or  to close the menu.

Using Teletext

Selecting Decoding Page Language

1. Press  on the remote control, select Channel > Teletext > Decoding page language and press OK/▶ to enter.
2. Press ▲/▼ to select a proper type of language in which Teletext will display and press OK to confirm.
3. Press EXIT or  to close the menu.

Digital Teletext Language



On digital TV channels, depending on the broadcaster, you may be able to enjoy a service with multiple initial Teletext pages in different languages. This function allows you to select an available language as primary language, which relates to different initial Teletext pages.

1. Press  on the remote control, select Channel > Teletext > Digital teletext language and press OK/▶ to enter.
2. Press ▲/▼ to select a language and press OK to confirm.

3. Press EXIT or  to close the menu.



Network Wake Up

This function allows you to turn on your TV from standby mode via a network. To use this function, please make sure:

1. Your TV is connected to an effective home network;
2. The desired controller, such as a smartphone, is connected to the same network as your TV;
3. An app which supports network waking up function, such as YouTube, has been installed into the controller;
4. Networked standby is set to On in the Network menu under homepage by pressing  >  (Settings) > Network & Internet and use  to select Networked standby and press OK to activate.

When the TV is in networked standby mode, you can use the app to wake up the TV remotely



Notes:

- This feature is disabled if you press and hold the  button on the remote control and confirm to shut the TV down
- Before using the feature of network wake up, make sure  (Settings) > Device Preferences > Power > Instant power on is set to on.

T-Link

Use this function to search for CEC devices connected to the HDMI sockets in your TV and enable auto power on and auto standby between the TV and CEC devices.

Enabling or Disabling T-Link

1. Press  on the remote control, select System > T-Link and press OK/▶ to enter.
2. Press ▲/▼ to select T-Link and press OK/▶ to enter.
3. Press ▲/▼ to select On or Off and press OK to confirm.
4. Press EXIT or  to close the menu.

Using Auto Power On

Enables the TV to automatically power on when you power on a CEC device (e.g. DVD) with the device's remote. Select On to enable this function.

Using Auto Standby



Enables all CEC devices to automatically go to the standby mode when you turn off the TV with the TV remote. Select On to enable this function.



Note: the CEC functions depend on the devices connected and it is possible that some devices may not interoperate correctly when connected to this TV. The user manual or the manufacturer of the problematic devices should be consulted for further information.

Time Shift

(* not available for some models)

Allows you to pause, fast forward and rewind live TV, so you don't have to miss any part of your favourite programmes. Before you use the function, connect a USB drive to the TV first. For the first time, you should complete the disk setup for the USB drive.

Press  on the remote control and select Time shift, then press OK/▶ to confirm. (Note: this option is available only when Time shift is set to On: press  on the remote control, press ▲/▼ to select Settings> Channel> Time Shift, press OK/▶ to enter and use ▲/▼ to set Time Shift to On or Off.)

1. Follow the directions on the screen to do the disk setup if you use time shift for the first time.
 2. After the disk setup is done, time shift will start, and the time shift menu displays on the screen.
 3. For later use, press and select Time shift. press  OK to display the time shift menu and operate according to the on-screen prompt.
 4. Pressing  button on the remote control stops the time shift and exits.(for RC802V, you can find  button on the virtual remote control keyboard.)
- When the time shift menu disappears and only the timing of the time shift remains on the screen, you can press OK to call out the time shift menu.

Notes:

- Before you plug the USB drive to TV, make sure you have backed up the data on the drive to avoid unforeseen malfunction and data loss.
- We recommend that you use a USB drive with at least 1GB free space and a disk speed faster than 5.0MB/sec.









The bigger the USB drive free space for time shift, the bigger the recording length.

Quick Access of Time Shift

Insert a USB disk, press PAUSE() on the remote control, it will access time shift automatically. (Available for RC802N remote control only.)

Reset Shop

Allows you to reset the TV to factory default settings.

1. Press  on the remote control to display the homepage, Press // to select  (Settings) > Device Preferences > Reset and press OK/ to enter.
2. Press / to select Factory data reset and press OK to enter. Then select Erase everything and press OK to confirm.
3. Enter 1234 or the PIN according to the on-screen prompt.
4. Select OK and press OK to confirm.
5. The Initial setup wizard appears. Follow the instructions in the section Initial setup.



Password in Parental Control

- The default password is 1234. You can change it to a new one.
- The super password is 0423. If you forget your code, enter the super password to override any existing codes.

Using the Hands-free TV Voice Control

(* not available for some models)

Before using the hands-free TV voice control, connect the TV to the network and make sure it can access the Google website first. Then follow the steps below to access.

1. Turn the built-in MIC switch (next to the power button) to on before using this function.
2. Access the Android TV homepage by pressing  on the remote control.
3. Select  (Settings) > Quick Settings > 'Ok Google' detection and press OK to turn it on. You can also set it by selecting  (Settings) > Device Preferences > Google Assistant > 'Ok Google' detection.
4. Say "OK Google" to activate it.

Notes:

- The availability of hands-free TV voice control depends on your region/country/language and your model. For details, please refer to your local dealer.
- A quiet surrounding is required for better function when using it. The recommended using distance is within 2 meters in front of TV set.
- Turn the built-in MIC switch to off if you are not going to use it. Or set the 'Ok Google' detection to off.
- Standby power consumption will increase because the built-in MIC is always listening when the Google Assistant or voice control with the built-in MIC is enabled.

Other Information

Problems & Solutions

Note: problems & solutions 1 to 2 are for the TV models which have network functions, so users of non-connected TV models can disregard them.

1. Fail to link to the network.

- Check if your TV is connected with the network;
- Reboot your TV;
- Consult your internet service provider, to confirm if access of your router is supported. Refer to the operation manual of your router.
- Make sure your TV is connected to a router, and make sure your router is powered on. Check that your router/modem has an internet connection, and that your Ethernet cables/wireless connection is OK. Test your connection with a computer to make sure it is OK. Should the problem persist, contact customer service.

2. The video could not be played smoothly.

- Videos from your USB flash drive --- It may result from data transmission, or its code flow is far beyond the supported formats of this TV set.
- Videos downloaded from internet, or online videos.

a. It may be caused by the lower bandwidth of your network. A high network speed is required to handle online videos.

b. Peak internet usage times may affect the bandwidth.

c. Check if any other computers on the same network are also operating, as they may be using up bandwidth. Especially if they are downloading or playing on-line videos.

d. The video may not be smooth itself, it is not the problem of your TV or network.

3. When two mobile hard disks are connected with the TV at the same time, they will not be recognized some times.

- All mobile hard disks consume a lot of power, which may result in power supply problems. We recommend inserting only one hard disk, or a low power consumption mobile hard disk.

4. The video from a mobile hard disk (USB) is playing with no sound.

- The audio format of the video in your mobile hard disk is not supported by the TV player.

5. Some videos fail to play.

- The formats of the videos may not be supported by the TV, especially videos shot by certain kinds of cameras, generally with their private protocol of formats, which are not compatible with your TV.

6. Video stops playing midway.

- Mistakes may occur when videos are copied or compressed, so they may automatically stop playing during playback.

7. What should I pay attention to, when I do SW updating?

- No power cuts when SW updating;
- Avoid any operations with your remote control when SW updating;
- Depending on your internet connection speed, the software updating process may take some time.

8. There are no distinct changes of TV interface after SW updating.

- Under certain conditions, SW updating may not only update or add new functions but also improve the performance of the TV set, without distinct changes to the user interface. Also, there may be no changes to the user interface at all.

9. What should I do when SW updating process stops due to a sudden power-off?

- If you do SW updating by USB, do not pluck the USB from your TV, and restart your TV to continue SW updating; If you do SW updating by Network, also restart your TV and check if it is well functioned.

10. With a USB device being inserted into the TV in advance, I am prompted that no USB devices are detected after I access Media, why?

- There may be something wrong with your mobile hard disk(s), damaged or with low voltage. You could increase power supply by inserting the two plugs on one end on the USB wire into TV's USB port simultaneously.

11. External device cannot be recognized.

- Some external devices (e.g. webcam, smart phone, tablet, game handle, and external wireless adapter) may not be compatible with the TV and cannot be supported for certain functions (nScreen, wireless display, gesture control, face recognition, if any). Please try a similar device. If it does not work, contact your local dealer.

12. Voice search does not work.

- Check if your remote control has been successfully paired with your TV.
- Check if the language setting is correct.
- Check if Google server is available and stable.

Troubleshooting

Most problems you encounter with your TV can be corrected by consulting the following troubleshooting list.

No picture, no sound

1. Check if the fuse or circuit breaker is working.
2. Plug another electrical device into the outlet to make sure it is working or turned on.
3. Power plug is in a bad contact with the outlet.
4. Check the signal source.

No colour

1. Change the colour system.
2. Adjust the saturation.
3. Try another channel. Black-white programme may be received.

Remote control does not work

1. Change the batteries.
2. Batteries are not installed correctly.
3. Main power is not connected.

No picture, normal sound

1. Adjust the brightness and contrast.
2. Broadcasting failure may happen.

Normal picture, no sound

1. Press the VOLUME UP button to increase volume.
2. Volume is set to mute, press the Mute button to restore sound. (Available for RC802N remote control only.)
3. Change the sound system.
4. Broadcasting failure may happen.

Unorderly ripples on the picture

It is usually caused by local interference, such as cars, daylight lamps and hair driers. Adjust the antenna to minimize the interference.

Snowy dots and interference

If the antenna is located in the fringe area of a television signal where the signal is weak, the picture may be marred by dots. When the signal is extremely weak, it may be necessary to install a special antenna to improve the reception.

1. Adjust the position and orientation of the indoor/ outdoor antenna.
2. Check the connection of antenna.
3. Fine tune the channel.
4. Try another channel. Broadcasting failure may happen.

Ignition

Black spots or horizontal streaks appear, or the picture flutters or drifts. This is usually caused by interference from car ignition system, neon lamps, electric drills, or other electrical appliance.

Ghost

Ghosts are caused by the television signal following two paths. One is the direct path, the other is reflected from tall buildings, hills, or other objects. Changing the direction or position of the antenna may improve the reception.

Radio frequency interference

This interference produces moving ripples or diagonal streaks, and in some case, loss of contrast in the picture. Find out and remove the radio interference source.

**To bring you better visual experience, please remove all labels, if any, from TV front panel and screen before use.*

**Figures and illustrations in this User Manual are provided for reference only and may differ from actual product appearance. Product design and specifications may be changed without notice.*

Warning

This content is compiled from multiple sources and is provided for reference purposes only. It may not be complete or fully applicable to all situations. If you are unable to resolve your issue, please contact the product manufacturer or an authorized service provider for official support.