

USING YOUR OVEN

Features

Throughout this manual, features and appearance may vary from your model.

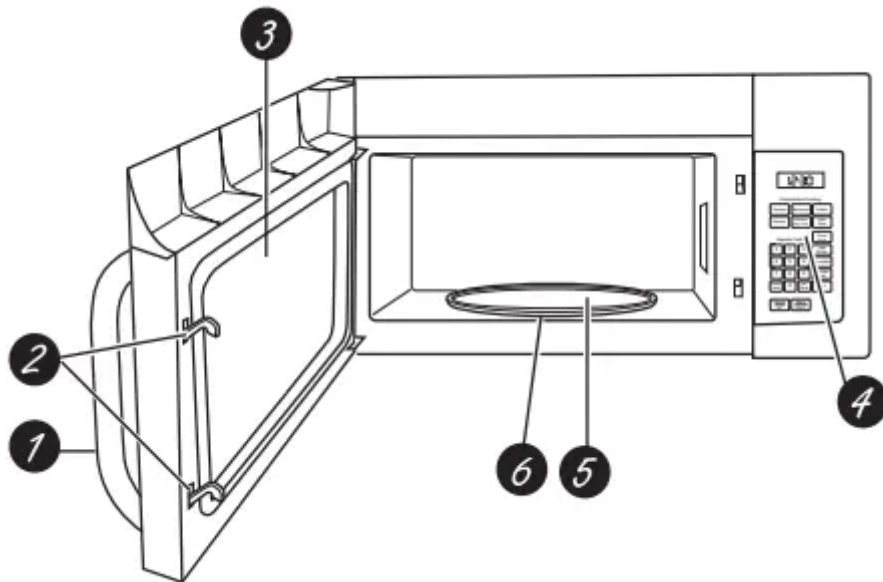

1. Door Latches
2. Window with Metal Shield. Screen allows cooking to be viewed while keeping microwaves confined in the oven.
3. Window with Metal Shield. Screen allows cooking to be viewed while keeping microwaves confined the oven.
4. Control Panel.
5. Removable Turntable. Turntable and support must be in place when using the oven. The turntable may be removed for cleaning.
6. Removable Turntable Support. The turntable support must be in place when using the oven.

Changing the power level

Changing the Power Level: The power level may be entered or changed before or during cooking. Power Level is set for Level 10 (High) unless it is changed.

1. Press Power Level button.
2. Enter new power level by using the number pads or press the Power Level button multiple times until you find the level you want.

3. After you have selected the power level, wait five seconds. The display will go back to the Cook Time screen.
4. Enter cooking time and press START.

OR

1. Press Cook Time button.
2. Enter your cooking time.
3. Press Power Level button.
4. Enter new power level by using the number pads or press the Power Level button multiple times until you find the level you want.
5. After you have selected the power level, wait five seconds. The display will go back to the Cook Time (Enter Time) screen.
6. Press START

Variable power levels add flexibility to microwave cooking. The power levels on the microwave oven can be compared to the surface units on a range. Each power level gives you microwave energy a certain percent of the time. Power level 7 is microwave energy of the time. Power level 3 is energy 30% of the time. Most cooking will be done on High (power level 10) which gives you 100% power. Power level 10 will cook faster but food may need more frequent stirring, rotating or turning over. A lower setting will cook more evenly and need less stirring or rotating of the food. Some foods may have better flavor, texture or appearance if one of the lower settings is used. Use a lower power level when cooking foods that have a tendency to boil over, such as scalloped potatoes and some casseroles. Rest periods (when the microwave energy cycles off) give time for the food to “equalize” or transfer heat to the inside of the food. An example of this is shown with Power level 3—the defrost cycle. If microwave energy did not cycle off, the outside of the food would cook before the inside was defrosted.

Here are some examples of uses for various power levels:

High 10 (100%): Fish, bacon, vegetables, boiling liquids.

Med-High 7 (70%): Gentle cooking of meat and poultry; baking casseroles and reheating.

Medium 5 (50%): Slow cooking and tenderizing for stews and less tender cuts of meat.

Low 2 or 3 (20 or 30%): Defrosting; simmering; delicate sauces.

Warm 1 (10%): Keeping food warm; softening butter

About the features

Cook Time

Allows you to microwave from 1 second to 99 minutes and seconds.

Power level 10 (HIGH) is automatically set, but you may change it for more flexibility.



1. Press Cook Time.
2. Enter cooking time.
3. Press START.

Cooking will start when the countdown begins in the display.

You may open the door during Cook Time to check the food. Close the door and press START to resume cooking.

Express Cook

This is a quick way to set cooking time from 1-6 minutes.

1. Press one of the Express Cook pads (from 1-6) for 1-6 minutes of cooking at power level 10. For example, press the 2 pad for 2 minutes of cooking time.

The power level can be changed as time is counting down. Press POWER LEVEL and enter 1-10.

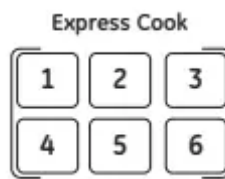

Add 30 Sec

It will add 30 seconds to the time counting down each time the pad is pressed. Each touch will add 30 seconds, up to minutes and 99 seconds.

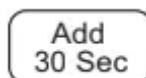

Add 30 sec can also be used like an express 30 seconds button. The microwave oven will start immediately when pressed

Popcorn

To use the Popcorn feature:

1. Press the POPCORN button once for 2.0 ounce bag, twice for ounce bag, or three times for a 3.0 ounce bag.
2. Press START.



Cooking will start when the countdown begins in the display.

You can not change the selection or quantity after the feature has started.

If food is undercooked after the countdown, use Cook Time for additional cooking time. We recommend 30 seconds and watch carefully.

Reheat

The Reheat feature reheats servings of previously cooked foods or a plate of leftovers.

Place the cup of liquid or covered food in the oven.

1. Press the REHEAT button up to six times to choose the correct selection.

Press once for a pizza.

Press twice for vegetables.

Press three times for a plate of leftovers.

Press four times for soup.

Press five times for meat.

Press six times for pasta.

2. Press the reheat pad again after food type has been entered in order to select quantity.

3. Press START.

Cooking will start when the countdown begins in the display



After removing food from the oven, stir, if possible, to even out the temperature. Reheated foods may have wide variations in temperature. Some areas of food may be extremely hot.

If food is not hot enough after the countdown use Cook Time for additional reheating time.

Some Foods Not Recommended for Use With Reheat

It is best to use Cook Time for these foods:

- Bread products.
- Foods that must be reheated uncovered.
- Foods that need to be stirred or rotated.
- Foods calling for a dry look or crisp surface after reheating

Beverage

Use the Beverage feature to heat various amounts of liquids measured in ounces: Place the liquid into the microwave oven

4 oz.	1/2 cup
8 oz.	1 cup
12 oz.	1-1/2 cups
16 oz.	2 cups

1. Press the Beverage button up to four times to choose the correct selection.

Press once for a 4 ounce beverage.

Press twice for a 8 ounce beverage.

Press three times for a 12 ounce beverage.

Press four times for a 16 ounce beverage.

2. Press START.

Cooking will start when the countdown begins in the display.



Potato

To use the Potato feature:

Place the potato(es) into the oven.

1. Press the Potato button up to four times to choose the correct selection.

Press once for 1 item.

Press twice for 2 items.

Press three times for 3 items.

Press four times for 4 items.

2. Press START.

Cooking will start when the countdown begins in the display.



Defrosting

Weight Defrost

Use Weight Defrost for meat, poultry and fish. Use Time Defrost for most other frozen foods. (Time Defrost is explained on page 13)



1. Press DEFROST once for Weight Defrost.
2. Enter the weight in pounds.
3. Press START.

Cooking will start when the countdown begins in the display.

Defrosting Tips

- Remove meat from package and place on microwavesafe dish.
- When the oven signals, turn the food over. Remove defrosted meat or shield warm areas with small pieces of foil.
- After defrosting, most meats need to stand 5 minutes to complete defrosting. Large roasts should stand for about 30 minutes.

Conversion Guide

If the weight of food is stated in pounds and ounces, the ounces must be converted to tenths (.1) of a pound.	
Ounces	Pounds
1-2	.1
3	.2
4-5	.3
6-7	.4
8	.5
9-10	.6
11	.7
12-13	.8
14-15	.9

Time Defrost

Allows you to defrost for a selected length of time. See the Defrosting Guide on page for suggested times (Weight Defrost is explained on page 12).



1. Press DEFROST twice for Time Defrost.
2. Enter defrosting time in minutes and seconds.
3. Press START.

Cooking will start when the countdown begins in the display.

At one half of selected defrosting time, turn food over and break apart or rearrange pieces for more even defrosting.

Shield any warm areas with small pieces of foil. The oven will continue to defrost if you don't open the door and turn the food.

Noises may be heard during defrosting. This is normal when oven is not operating at High power.

Defrosting Tips

- Foods frozen in paper or plastic can be defrosted in the package. Closed packages should be slit, pierced or vented AFTER food has partially defrosted. Plastic storage containers should be partially uncovered.
- Family-size, prepackaged frozen dinners can be defrosted and microwaved. If the food is in a foil container, transfer it to a microwave-safe dish.
- Foods that spoil easily should not be allowed to sit out for more than one hour after defrosting. Room temperature promotes the growth of harmful bacteria.
- For more even defrosting of larger foods, such as roasts, use Time Defrost. Be sure large meats are completely defrosted before cooking.
- When defrosted, food should be cool but softened in all areas. If still slightly icy, return to the microwave very briefly, or let it stand a few minutes.

Defrosting Guide

<i>Food</i>	<i>Time</i>	<i>Comments</i>
Breads, Cakes <i>Bread, buns, or rolls</i> (1 piece) <i>Sweet rolls</i> (approx. 12 oz.)	1/4 min. 2 to 4 min.	Rearrange after half the time.
Fish and Seafood <i>Filletts, frozen</i> (1 lb.) <i>Shellfish, small pieces</i> (1 lb.)	6 to 9 min. 3 to 7 min.	Place block in casserole. Turn over and break up after half the time.
Fruit <i>Plastic pouch—1 or 2</i> (10-oz. package)	1 to 5 min.	
Meat <i>Bacon</i> (1 lb.) <i>Franks</i> (1 lb.) <i>Ground meat</i> (1 lb.) <i>Roast: beef, lamb, veal, pork</i>	2 to 5 min. 2 to 5 min. 4 to 6 min. 9 to 13 min. per lb.	Place unopened package in oven. Let stand 5 minutes after defrosting. Place unopened package in oven. Microwave just until franks can be separated. Let stand 5 minutes, if necessary, to complete defrosting. Turn meat over after first half of time. Use power level 10.
Steaks, chops and cutlets	4 to 8 min. per lb.	Place unwrapped meat in cooking dish. Turn over after first half of time and shield warm areas with foil. After second half of time, separate pieces with table knife. Let stand to complete defrosting.
Poultry <i>Chicken, broiler-fryer, cut up</i> (2½ to 3 lbs.) <i>Chicken, whole</i> (2½ to 3 lbs.) <i>Cornish hen</i> <i>Turkey breast</i> (4 to 6 lbs.)	14 to 20 min. 20 to 25 min. 7 to 13 min. per lb. 3 to 8 min. per lb.	Place wrapped chicken in dish. Unwrap and turn over after first half of time. After second half of time, separate pieces and place in cooking dish. Microwave 2 to 4 minutes more, if necessary. Let stand a few minutes to finish defrosting. Place wrapped chicken in dish. After half the time, unwrap and turn chicken over. Shield warm areas with foil. To complete defrosting, run cold water in the cavity until giblets can be removed. Place unwrapped hen in the oven breast-side-up. Turn over after first half of time. Run cool water in the cavity until giblets can be removed. Place unwrapped breast in microwave-safe dish breast-side-down. After first half of time, turn breast-side-up and shield warm areas with foil. Defrost for second half of time. Let stand 1 to 2 hours in refrigerator to complete defrosting.



About the other features

Clock



To change the time of day.

1. Press the Set Clock button. (The microwave should not be running.)
2. Enter the appropriate time of day. Clock is on a 12-hour scale.
3. Press Set Clock or Start to accept the time.

Pause

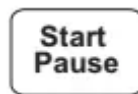

In addition to starting many functions, START/PAUSE allows you to stop cooking without opening the door or clearing the display and resume cooking later.

Child Lock-Out



Press the CANCEL/OFF button to stop and cancel cooking at any time.

Control Lock-Out



You may lock the control panel to prevent the oven from being accidentally started during cleaning or being used by children.

To lock or unlock the controls, press and hold the CANCEL/ OFF button for three seconds. When the control panel is locked, LOCKED will be displayed briefly anytime a button or dial is pressed. "L" will show in the display.

Surface Light

Press SURFACE LIGHT once for bright light, twice for the night light or a third time to turn the light off.

Timer

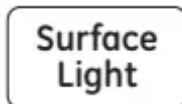

The Timer operates as a minute timer and can be used at any time, even when the oven is operating.

1. Press the Timer button.
2. Enter a time.
3. Press the Timer 3 Start button to start.

To cancel, press the Timer button or Cancel button.

Display

If you have the Timer counting down and you are using the Cook Time at the same time, you can change the display to show either the timer or the cook time countdown.

If the display shows the time for the Timer and you would like to view the Cook Time, press the COOK TIME button.



If the display shows the time for the Cook Time and you would like to view the Timer, press the TIMER button

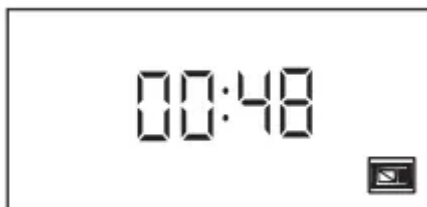

Turntable

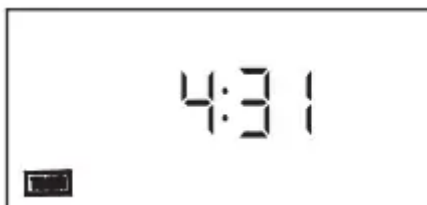

For best cooking results, leave the turntable on. It can be turned off for large dishes.

Press the Turntable pad once to turn the turntable off.

Press again to turn the turntable back on.

Sometimes the turntable can become too hot to touch. Be careful touching the turntable during and after cooking.

Turntable can be turned off during the Cook Time or Express Cook features by pressing the Turntable pad.

Vent Fan

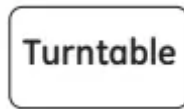

The vent fan removes steam and other vapors from surface cooking.

Press Vent Fan once for high fan speed, twice for low fan speed or three times to turn the fan off.

Automatic Fan

An automatic fan feature protects the microwave from too much heat rising from the cooktop below it. It automatically turns on if it senses too much heat.

If you have turned the fan on you may find that you cannot turn it off. The fan will automatically turn off when the internal parts are cool. It may stay on for 30 minutes or more after the cooktop and microwave controls are turned off

Insert Food Reminder

A reminder will show on the display if the user tries to start the cooking cycle without placing food inside the microwave oven within 5 minutes prior to starting the cooking cycle.

Cooking Complete Reminder

To remind you that you have food in the oven, the oven will display "Food is ready" and beep once a minute until you either open the oven door or press the CANCEL/OFF button.

Care and Cleaning

Helpful Hints

An occasional thorough wiping with a solution of baking soda and water keeps the inside fresh.

Unplug the cord before cleaning any part of this oven.

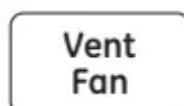

How to Clean the Inside

Walls, Floor, Inside Window, Metal and Plastic Parts on the Door

Some spatters can be removed with a paper towel; others may require a damp cloth. Remove greasy spatters with a sudsy cloth, then rinse with a damp cloth.

Do not use abrasive cleaners or sharp utensils on oven walls.

Never use a commercial oven cleaner on any part of your microwave.



Removable Turntable and Turntable Support

To prevent breakage, do not place the turntable into water just after cooking. Wash it carefully in warm, sudsy water or in the dishwasher. The turntable and support can be broken if dropped. Remember, do not operate the oven in the microwave mode without the turntable and support seated and in place.

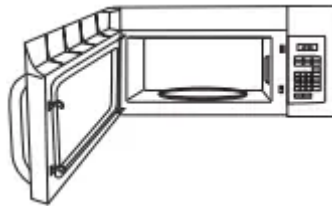

How to Clean the Outside

We recommend against the use of spray cleaners and using cleaners with ammonia or alcohol, as they can damage the appearance of the microwave oven. If you choose to use a common household cleaner, first apply the cleaner directly to a clean cloth, then wipe the soiled area.



Case

Clean the outside of the microwave with a sudsy cloth.

Rinse and then dry. Wipe the window clean with a damp cloth.

Control Panel

Wipe with a damp cloth. Dry thoroughly. Do not use cleaning sprays, large amounts of soap and water, abrasives or sharp objects on the panel—they can damage it. Some paper towels can also scratch the control panel.

Door Panel

Before cleaning the front door panel, make sure you know what type of panel you have. Refer to the eighth digit of the model number. “S” is stainless steel “B”, “W” or “C” are plastic colors.

Stainless Steel (on some models)

The stainless steel panel can be cleaned with Stainless

Steel Magic or a similar product using a clean, soft cloth.

Apply stainless cleaner carefully to avoid the surrounding plastic parts. Do not use appliance wax, polish, bleach or products containing chlorine on Stainless Steel finishes.

Plastic Color Panels

Use a clean, soft, lightly dampened cloth, then dry thoroughly.

Door Seal

It's important to keep the area clean where the door seals against the microwave. Use only mild, non-abrasive detergents applied with a clean sponge or soft cloth. Rinse well.

Bottom

Clean off the grease and dust on the bottom often. Use a solution of warm water and detergent.

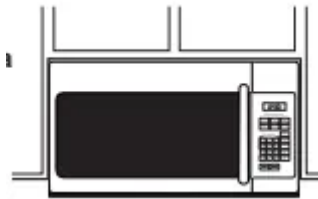

Removing and Cleaning the Filters

To remove, slide them to the rear using the tabs. Pull down and out.

To clean the vent filters, soak them and then swish around in hot water and detergent. Don't use ammonia or ammonia products because they will darken the metal. Light brushing can be used to remove embedded dirt.

Rinse, shake and let dry before replacing.

To replace, slide the filters into the frame slots on the back of each opening. Press up and to the front to lock into place.

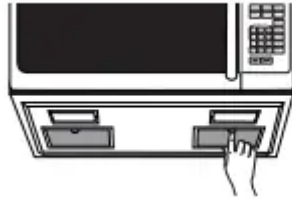

Charcoal Filter

The charcoal filter cannot be cleaned. It must be replaced. Order Part No. WB02X11550 from your GE supplier.

If the model is not vented to the outside, the air will be recirculated through a disposable charcoal filter that helps remove smoke and odors.

The charcoal filter should be replaced when it is noticeably dirty or discolored (usually after 6 to 12 months, depending on usage).

To Remove the Charcoal Filter

To remove the charcoal filter, first disconnect power at the main fuse or circuit breaker, or pull the plug. Remove the top grille by removing only the two screws that hold it in place, as shown.

You may need to open the cabinet doors to remove the screws.

Press back on the top of the filter with both hands until the filter lays down almost horizontal. Lift the filter at the bottom until it comes free of the tabs. Slide the filter down and out.

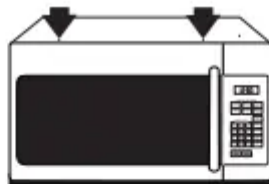

Remove 2 grille screws to remove the grille.

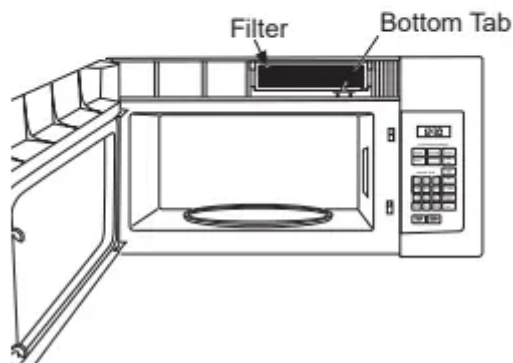

Replacing the Oven Cavity Lamp

1. Disconnect power at the main fuse or circuit breaker panel.
2. Remove the top grill by removing the two screws that hold it in place.
3. Remove charcoal filter if present. NOTE: Charcoal filter is an optional kit, you may not have one.
4. Press the retainer holding the lamp shield in place.
5. Pull the lamp shield out. Unscrew the light bulb out and replace with the 120V-130V, 30W incandescent bulb. Order WB25X10029 from your GE supplier.
6. Return the lamp and lamp shield to original position and replace charcoal filter.
7. Replace the grill and 2 screws. Reconnect power to the oven.

Cooktop Lights/Nite Lights

Replace with 120 volt, 40 watt (max) incandescent bulbs. Order WB25X10030 from your GE supplier.

1. To replace the cooktop lights/nite lights, first disconnect the power at the main fuse or circuit breaker panel, or pull the plug.
2. One side at a time, remove the screw from the side of the light compartment cover and lower the cover until it stops.
3. Be sure the bulb is cool before removing. Break the adhesive seal by gently unscrewing the bulb.
4. Screw in the new bulb, then raise the light cover and replace the screw. Repeat for the other light. Connect electrical power to the oven.



Vent Fan

The vent fan has two metal reusable vent filters.

Models that recirculate air back into the room also use a charcoal filter.

Reusable Vent Filters

The metal filters trap grease released by foods on the cooktop. They also prevent flames from foods on the cooktop from damaging the inside of the oven.

For this reason, the filters must always be in place when the hood is used. The vent filters should be cleaned once a month, or as needed.

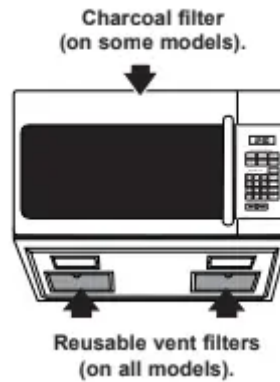

To Install the Charcoal Filter

To install a new charcoal filter, remove plastic and other outer wrapping from the new filter.

Insert the top of the filter up and into the grooves on both sides of the inside of the top opening. Once you have cleared the bottom tab, push the bottom of the filter in until it rests in place vertically behind the tab.

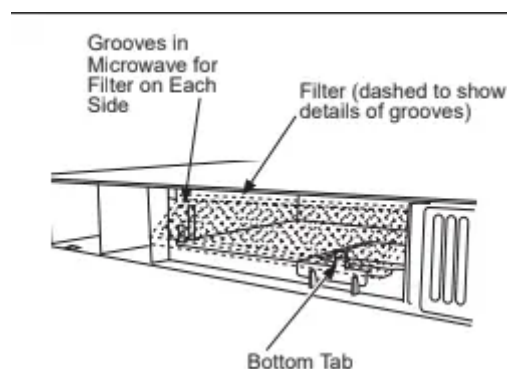
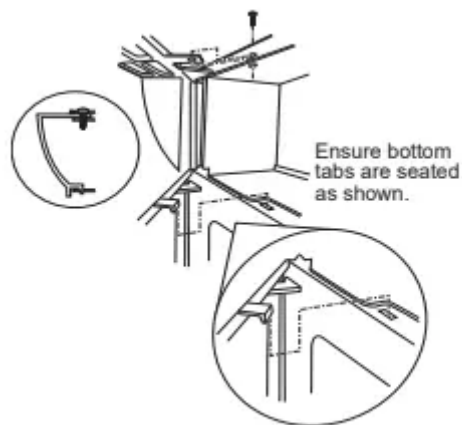

TROUBLESHOOTING TIPS

Microwave Terms

- Arcing
 - Arcing is the microwave term for sparks in the oven. Arcing is caused by:
 - metal or foil touching the side of the oven.
 - foil that is not molded to food (upturned edges act like antennas).
 - metal such as twist-ties, poultry pins, gold-rimmed dishes.
 - recycled paper towels containing small metal pieces.
 - plates or dishes with a metallic trim or glaze with a metallic sheen.
- Covering
 - Covers hold in moisture, allow for more even heating and reduce cooking time. Venting plastic wrap or covering with wax paper allows excess steam to escape.
- Shielding
 - In a regular oven, you shield chicken breasts or baked foods to prevent over-browning. When microwaving, you use small strips of foil to shield thin parts, such as the tips of wings and legs on poultry, which would cook before larger parts.
- Standing Time
 - When you cook with regular ovens, foods such as roasts or cakes are allowed to stand to finish cooking or to set. Standing time is especially important in microwave cooking. Note that a microwaved cake is not placed on a cooling rack.
- Venting
 - After covering a dish with plastic wrap, you vent the plastic wrap by turning back one corner so excess steam can escape.

Oven will not start

- A fuse in your home may be blown or the circuit breaker tripped.
 - Replace fuse or reset circuit breaker.
- Power surge.
 - Unplug the microwave oven, then plug it back in.

- Plug not fully inserted into wall outlet
 - Make sure the 3-prong plug on the oven is fully inserted into wall outlet.
- Door not securely closed.
 - Open the door and close securely.

Control panel lighted, yet oven will not start

- Door not securely closed.
 - Open the door and close securely.
- START/PAUSE button not pressed after entering cooking selection.
 - Press START/PAUSE.
- Another selection entered already in oven and CANCEL/OFF button not pressed to cancel it.
 - Press CANCEL/OFF.
- Cooking time not entered after pressing COOK TIME
 - Make sure you have entered cooking time after pressing COOK TIME.
- CANCEL/OFF was pressed accidentally.
 - Reset cooking program and press START/ PAUSE.

CONTROL LOCKED appears on display

- The control has been locked.
 - Press and hold CANCEL/OFF for about 3 seconds to unlock the control.

Floor of the oven is warm even when the oven has not been used

- The cooktop light is located below the oven floor. When light is on, the heat it produces may make the oven floor get warm.
 - This is normal.

You hear an unusual low-tone beep

- You have tried to change the power level when it is not allowed
 - Many of the oven's features are preset and cannot be changed.

Vent fan comes on automatically

- The vent fan automatically turns on to protect the microwave if it senses too much heat rising from the cooktop below.
 - This is normal.

Things That Are Normal With Your Microwave Oven

- Moisture on the oven door and walls while cooking. Wipe the moisture off with a paper towel or soft cloth.
- Moisture between the oven door panels when cooking certain foods. Moisture should dissipate shortly after cooking is finished.
- Steam or vapor escaping from around the door.
- Light reflection around door or outer case.
- Dimming oven light and change in the blower sound at power levels other than high.
- Noises while oven is operating.
- TV/radio interference might be noticed while using the microwave. Similar to the interference caused by other small appliances, it does not indicate a problem with the microwave. Plug the microwave into a different electrical circuit, move the radio or TV as far away from the microwave as possible, or check the position and signal of the TV/radio antenna.

Warning

This content is compiled from multiple sources and is provided for reference purposes only. It may not be complete or fully applicable to all situations. If you are unable to resolve your issue, please contact the product manufacturer or an authorized service provider for official support.