

Installation

The docking station must be plugged in and turned on at all times.

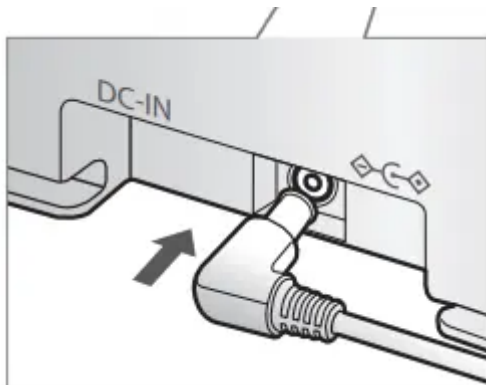

1. Connect the battery charger jack to the docking station

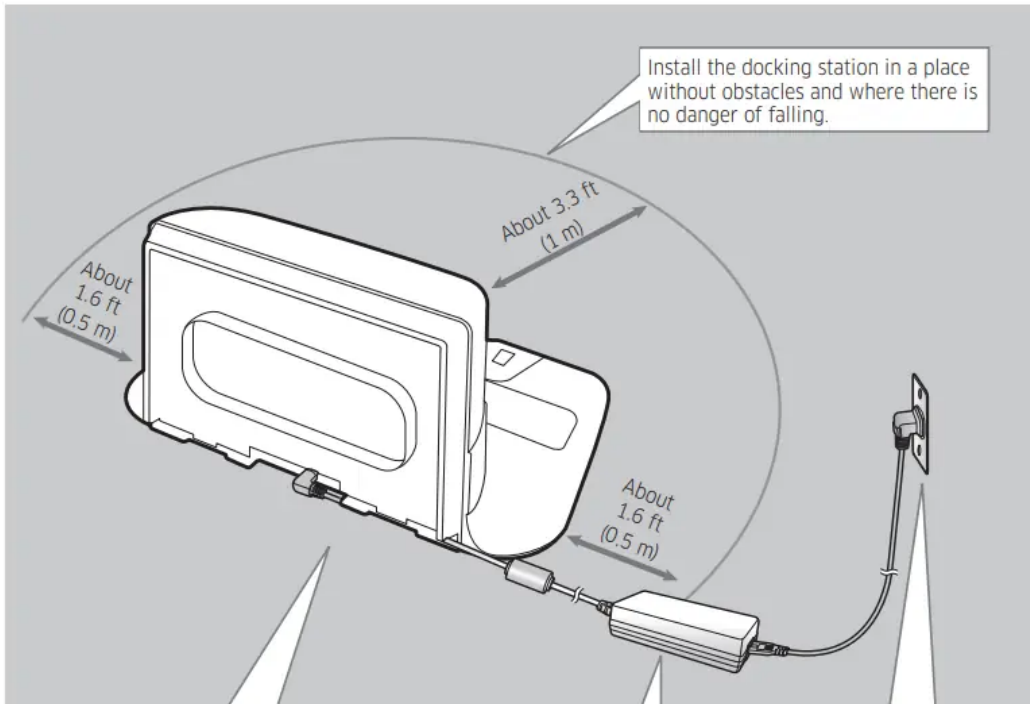
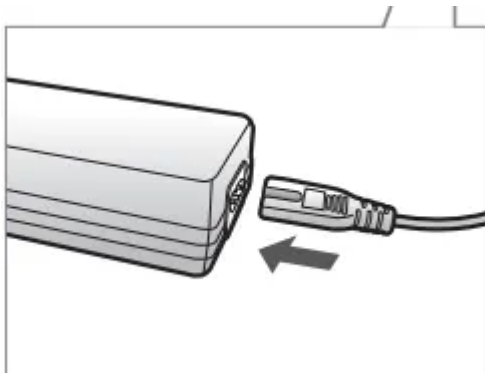



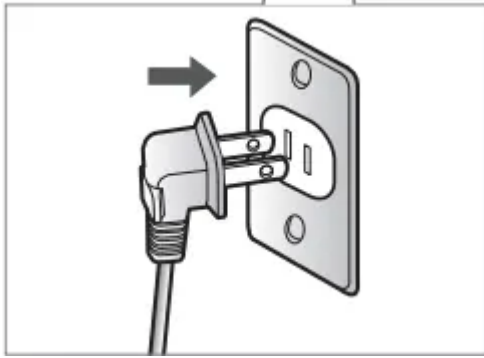

2. Connect the power cord to the battery charger

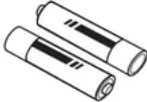
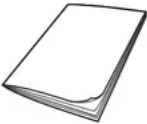
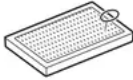

3. Connect the power plug to the outlet

Accessories

 <p>or</p> <p>Remote control (Optional)</p>	 <p>Batteries (AAA type) (Optional)</p>	 <p>User manual</p>	 <p>Spare filter (Optional)</p>
 <p>Docking station</p>	 <p>Power cord</p>	 <p>Battery charger</p>	 <p>Boundary markers (Optional)</p>

* Accessories may differ depending on the models.

* Refer to page 17 for the installation of boundary markers.

Installation note

Note

- Install the docking station in a place where the floor is level and the wall is straight.
- It is best to install the docking station along the grain of wooden floors.
- If the emergency switch is off, the POWERbot will not charge even if it is docked in the docking station.
- Always turn on the power of the docking station.
- If power is not supplied to the docking station, the POWERbot cannot find it and cannot automatically recharge.
- If the POWERbot is left detached from the docking station, the battery will drain.

- If the POWERbot is in sleep mode, power will not come on even if the emergency switch is turned off and then on. Press and hold the [Start/Stop] button on the POWERbot to turn the sleep mode off.

Using POWERbot

You must turn on the emergency switch on the bottom of the unit before using POWERbot

Turning the power on/off



Press the button for more than 3 seconds



When POWERbot is not used for 30 min.;

SR1AM70**U* / SR2AM70**U* series: Enters energy-saving mode.

SR1AM70**W* / SR2AM70**W* series: Automatically returns to the docking station to be charged.

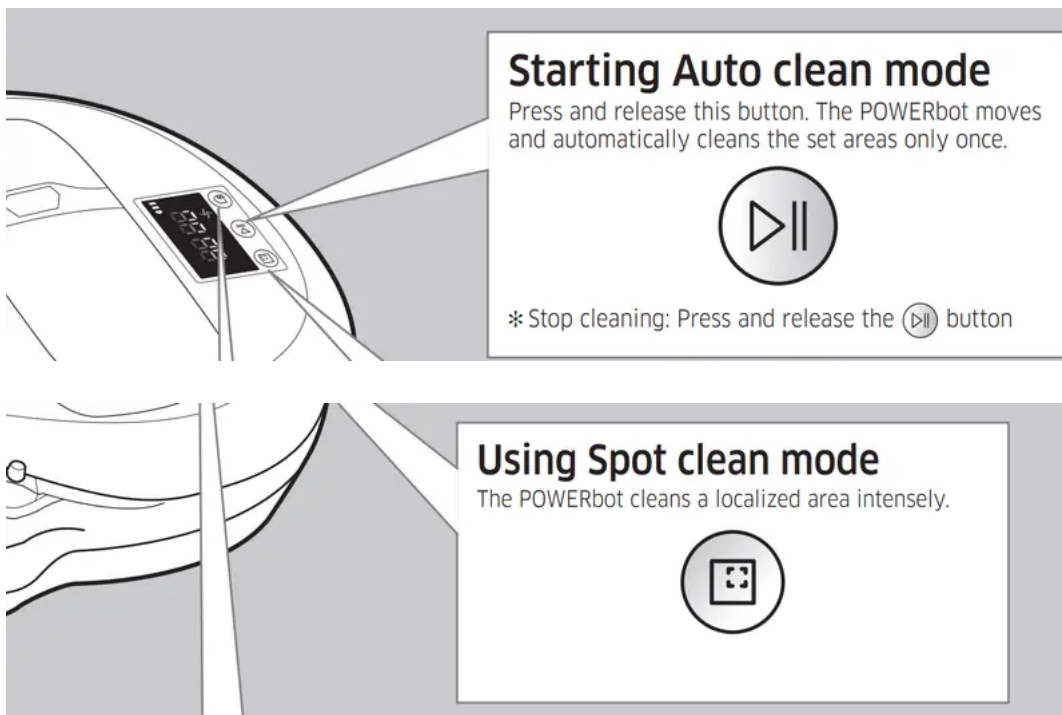

Recharging/Energy-saving mode

▶ Recharging

You can command POWERbot to recharge at the docking station automatically while it is cleaning by pressing this button.

▶ Energy-saving mode

Refer to page 17.



Selecting cleaning modes

Cleaning mode	How to select	Displayed icons	
		SR1AM7040W* SR2AM70****	SR1AM7010U*
Auto clean			
Spot clean			
Repeat clean	* Press the [A,B type], [C type] on the remote controller first, and then press the [Start/Stop].		-
Manual clean	* You can select manual clean mode using the direction control buttons on the remote control.		-

* If POWERbot fails to return to the docking station, it will enter energy-saving mode and the display panel will be turned off.

* To exit the energy-saving mode, press the [Start/Stop] or [Power] button on the main body or the remote control.

* If cleaning in Auto clean mode is completed within 15 minutes, POWERbot cleans 1 more time.

Cleaning method for each mode

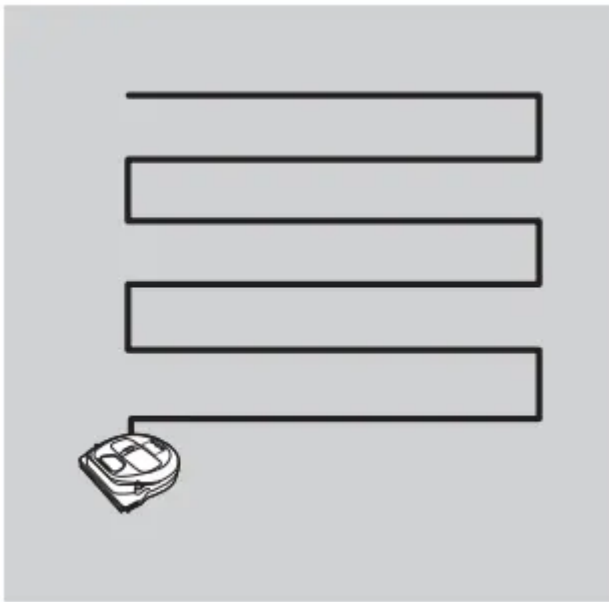

Auto clean

Automatically cleans the set areas only once.

* SR1AM7010U* series : Cleans repeatedly until the battery is depleted.

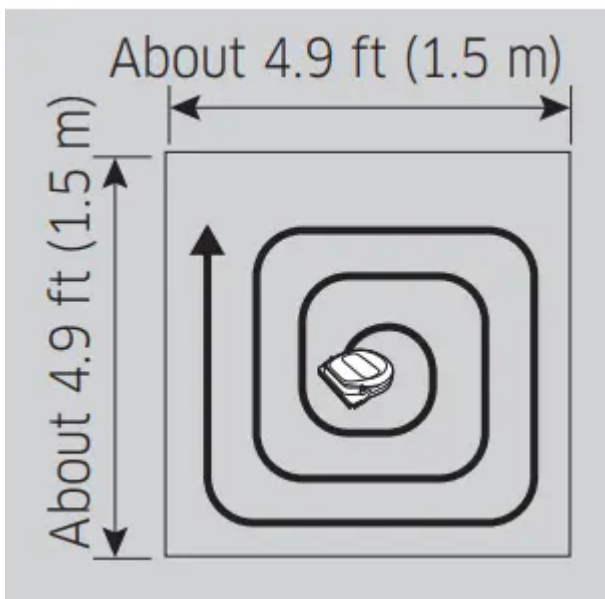

Spot clean

Cleans a localized area intensely. It can be used to clean bread or cookie crumbs.



Manual clean

You can move POWERbot with the remote control to clean the desired spot.

* This function is not available on the SR1AM7010U* series.

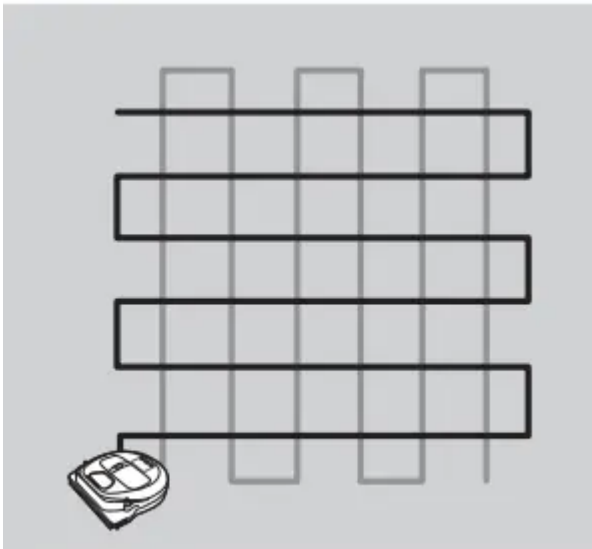

Repeat clean





Cleans repeatedly until the battery is depleted.

* This function is not available on the SR1AM7010U* series.

Note

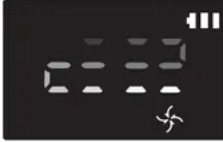
- If you select Auto clean or Repeat clean, the POWERbot cleans the area near the docking station first

Using special cleaning functions

Cleaning function	Operation	Displayed icons	
		SR1AM7040W* SR2AM70****	SR1AM7010U*
Intelligent power control	* When the POWERbot detects a carpet in normal mode, it will automatically operate with stronger suction power.		
Edge clean master	* When the POWERbot detects an edge or corner in Auto clean or Spot clean, the auto shutter tool operates and approaches the edge or corner section to clean. ▶ Straight edge (One time cleaning) ▶ Corner (Cleans twice)		

About the boundary markers



To prevent the POWERbot from entering the following areas, place the boundary markers on the floor in a shape at intervals of about 5.9 in (15 cm).

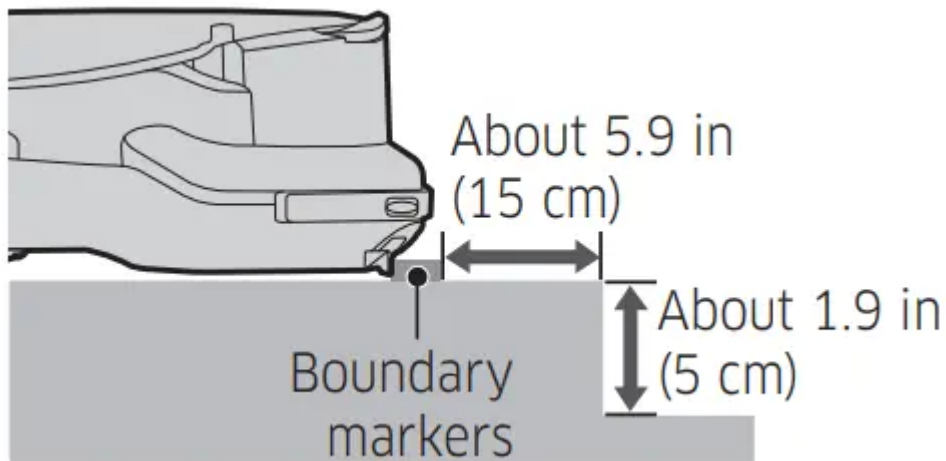

Where a raised spot exceeds 1.9 in (5 cm)

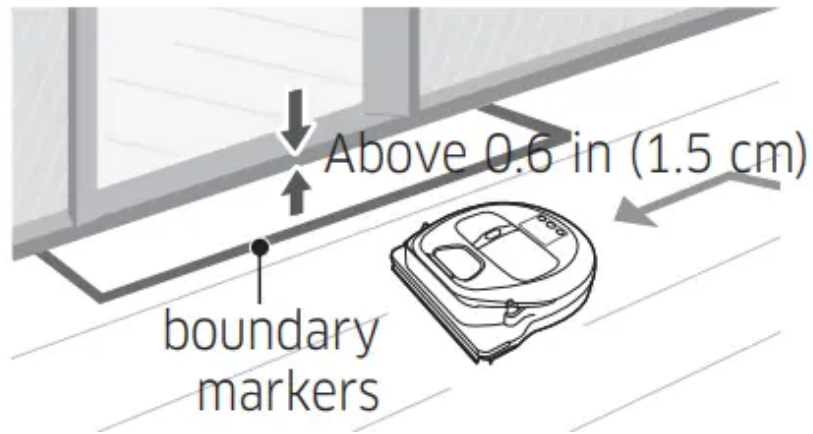

Where a threshold is higher than 0.6 in (1.5 cm)

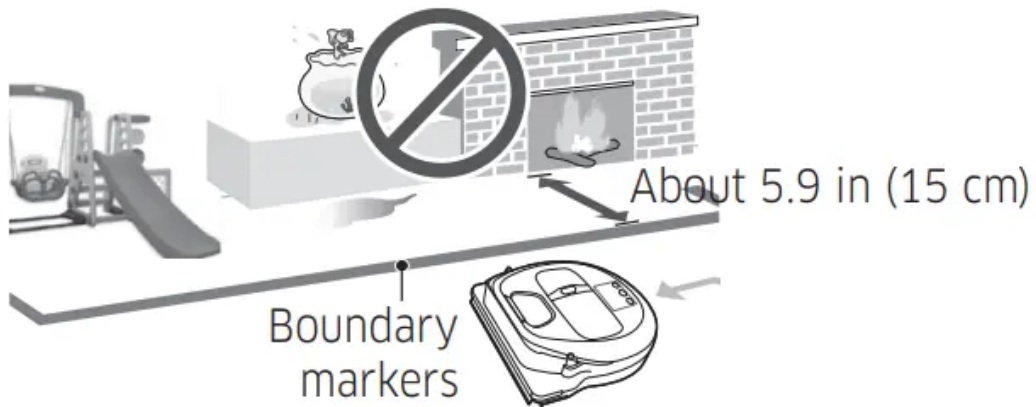

Where there is a slide, swing, fireplace, or any flammable substance or moisture.

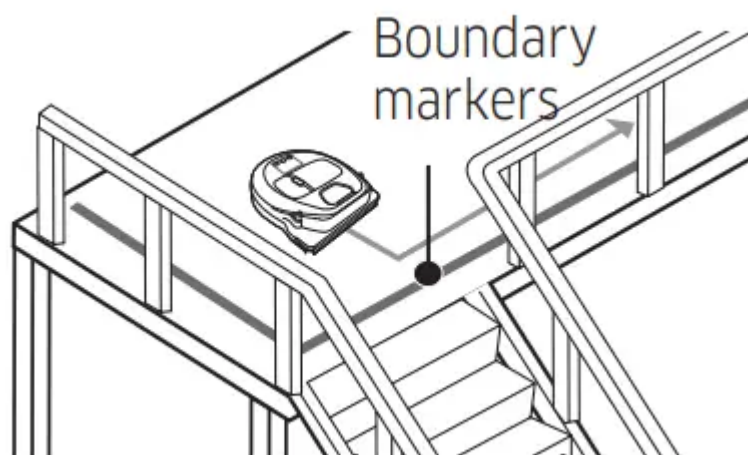

Where there is risk of falling such as near stairs, porches, or guardrails.

Using Energy-saving mode

ou can select the Energy-saving mode to save energy during battery charging. Energy-saving mode turns off all functions except battery charging. Use it to reduce power consumption while you are away from home for an extended period of time.

How to select or cancel		Displayed icon	
	Press  for 5 sec.		<p><SR1AM7010U* series only></p>  Blinking Blinking

Note

- If you select the Auto/Max/Manual clean mode or press the Point cleaning button, the Energy-saving mode will be cancelled.
- When Energy-saving mode is on, setting the schedule will cancel Energy-saving mode. – If you select the Energy-saving mode after setting the schedule, the schedule will not be cancelled.
- If the docking station is off, Energy-saving mode will be cancelled.
- If the battery is completely flat, place the POWERbot on the docking station, and then press the [Start/Stop] button on the main body

Using the remote control

[A Type]

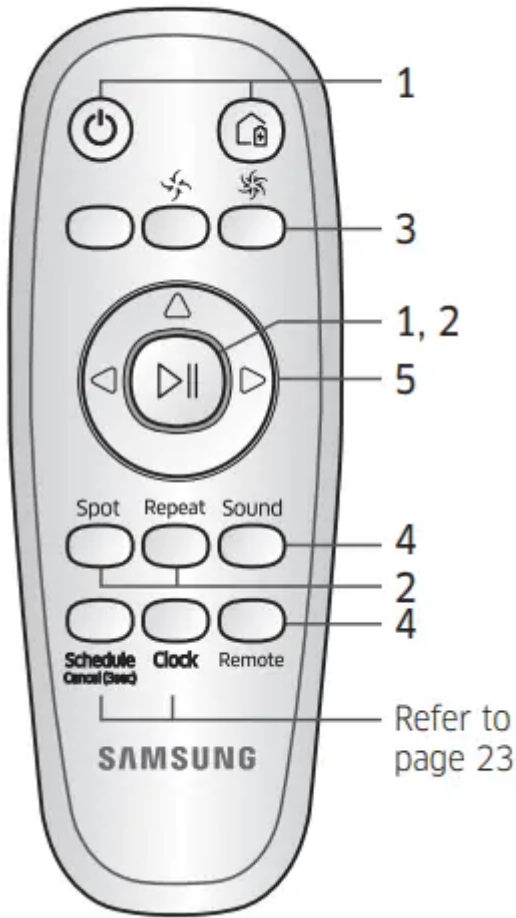

[B Type]

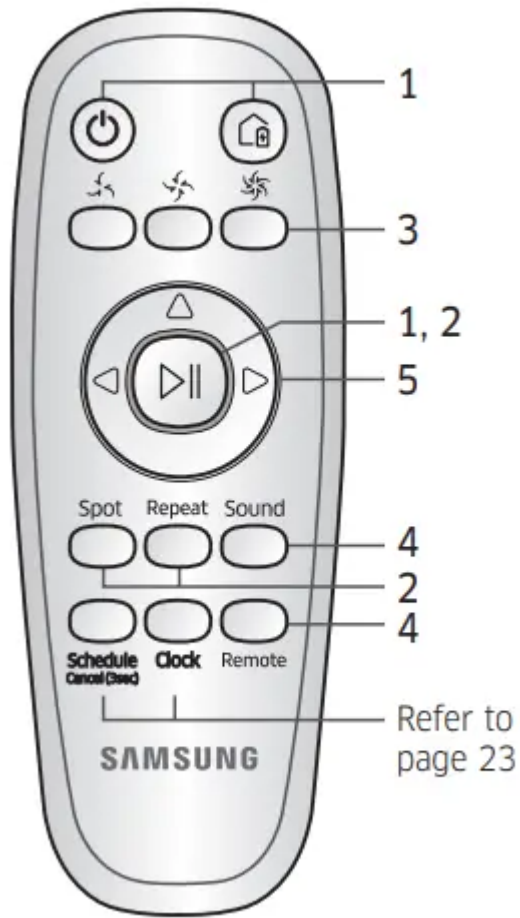

[C Type]

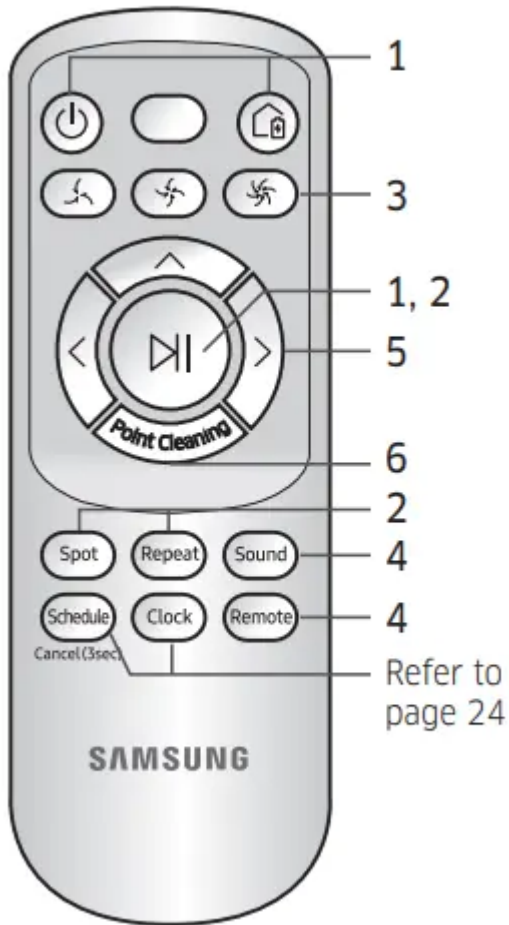









1 Power / Recharging / Start/Stop

Power				Turn POWERbot's power on/off
Recharging				Select to recharge POWERbot at the docking station automatically
Start/Stop				Select to start or stop the cleaning process







2 Cleaning modes

Auto clean				Select to clean all set areas only once and then have the POWERbot automatically return to the docking station.
Spot clean				Select to clean a localized area intensely
Repeat clean				Select to clean repeatedly until the battery becomes very low and the battery level indicator blinks

3 Suction power

Turbo mode				Select to clean with the strongest suction power
Normal mode				Select to clean with moderate suction power
Quiet mode				Select to clean with lower operational noise









4 Additional function

Sound				Each time you press this button, Sound Effects → Mute is selected in sequence <SR1AM7040W9 series only> Star wars → Sound Effects → Mute
Remote control				Select to turn the Wi-Fi function on or off

* SR1AM7010U5 series only: Star wars (Mute function is not available.)

* Turning the emergency switch off and then on will not cancel or change the settings

5 Manual clean mode & Direction control

Move forward				Select to move forward
Turn left				Select to turn left
Turn right				Select to turn right

* Moving backward is not available.

6 Point cleaning

Available only with C type remote controllers.

You can use the remote control to direct the POWERbot to clean a desired spot while the POWERbot is cleaning.

Point the red light on the floor within 1.6 ft (0.5 m) of the POWERbot's location.

Press and hold the Point cleaning button to move the red light to the desired spot. The POWERbot will follow the light while cleaning

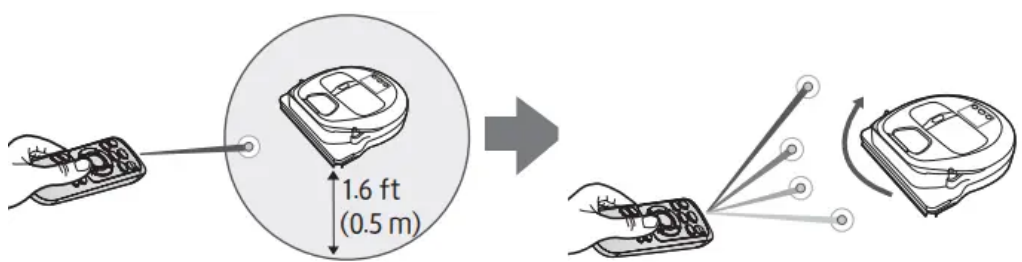

Operating distance of the remote control

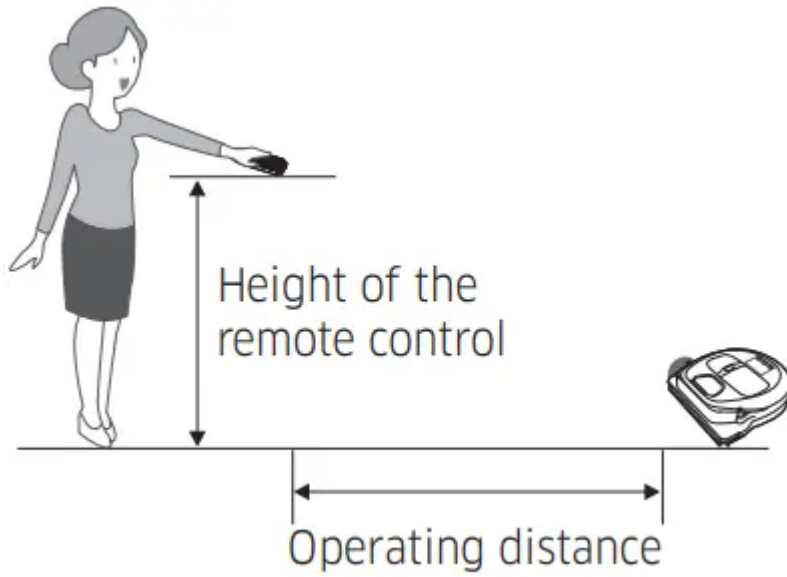

Height of the remote control	1.6 ft (0.5 m)	3.3 ft (1 m)	4.9 ft (1.5 m)
Operating distance	About 4.9 ft (1.5 m)	About 6.6 ft (2 m)	About 9.8 ft (3 m)

Inserting batteries

Open the battery cover by lifting it up while pressing the locking tab. Insert the batteries as shown in the illustration, and then close the cover until it clicks into place.

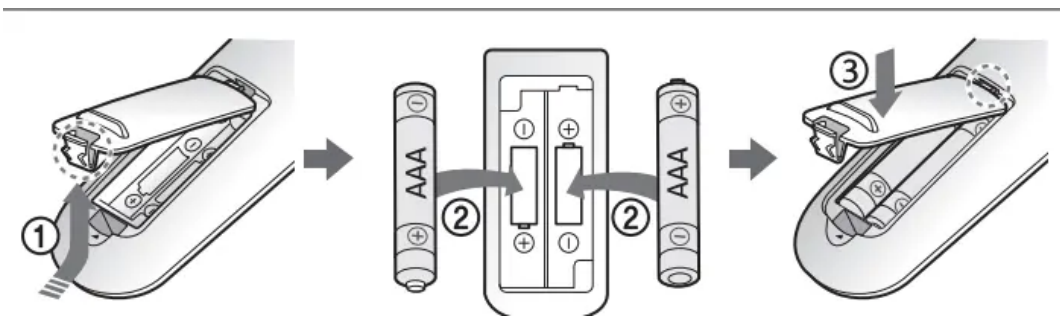

Name of each part

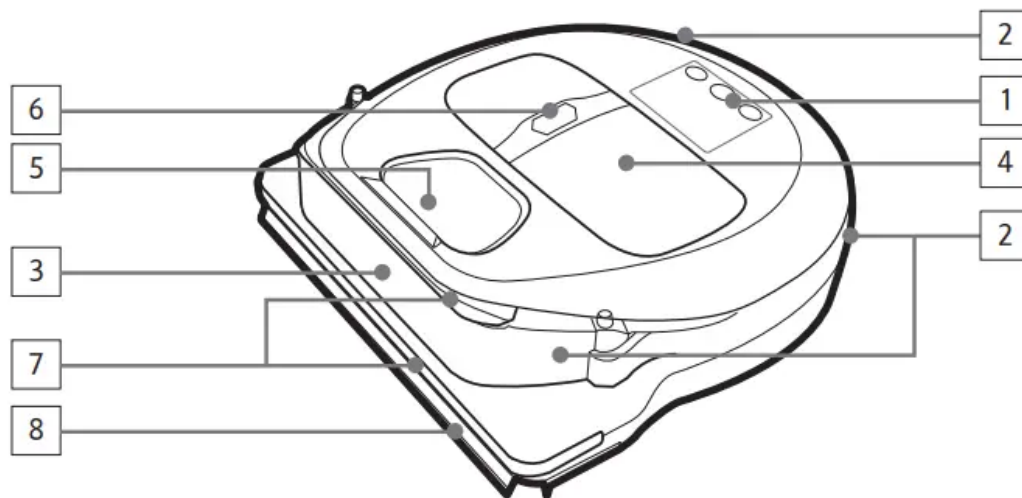

Top

1. Display panel
2. Remote control signal receiver
3. Obstacle sensor
4. Dustbin
5. Camera
6. Dustbin button
7. Bumper sensor
8. Auto shutter tool

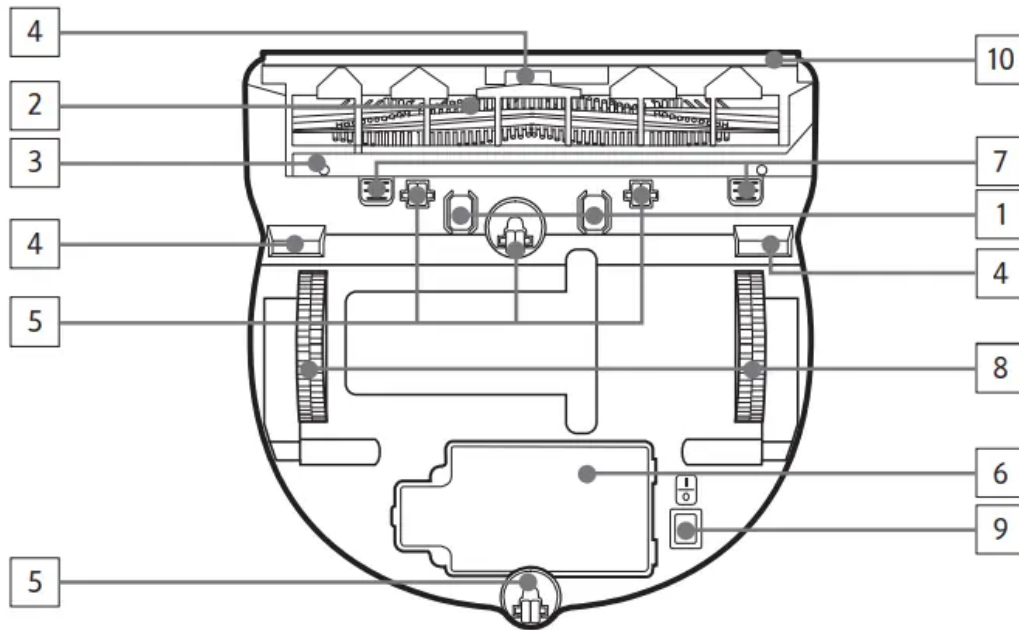

Bottom

- 1. Charging pins
- 2. Brush
- 3. Brush cover
- 4. Cliff sensor
- 5. Roller
- 6. Battery cover
- 7. Brush cover button
- 8. Driving wheel
- 9. Emergency switch
- 10. Auto shutter tool



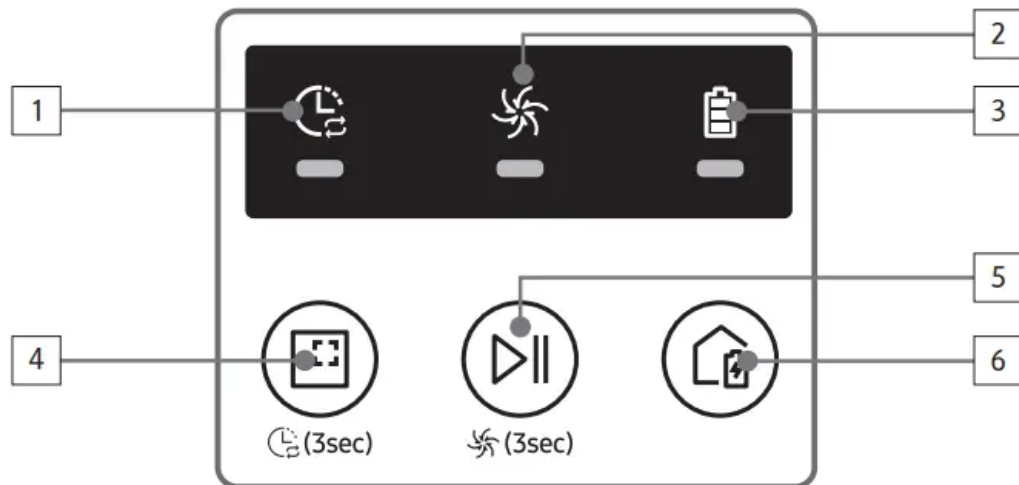

Display panel

1. Daily schedule
2. Normal/Turbo mode
3. Battery indicator
4. Spot cleaning button, daily schedule (3sec)
5. Start/Stop button, Turbo mode (3sec)
6. Recharging button

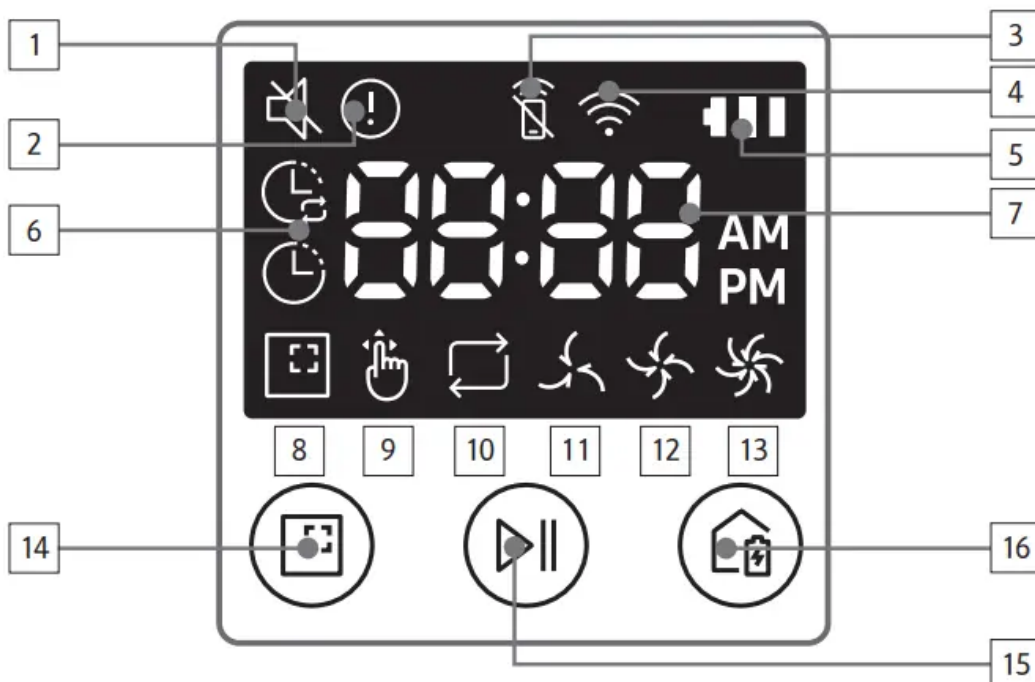

1. Mute
2. Information Indicator
3. *Smart Control Off/On indicator
4. *Wi-Fi
5. Battery indicator
6. One-time/Daily schedule
7. Number display
8. Spot clean mode
9. Manual clean mode
10. Repeat clean mode
11. Quiet mode
12. Normal mode
13. Turbo mode
14. Spot cleaning button
15. Start/Stop button
16. Recharging button

* SR1AM70**W* / SR2AM70**W* : Wi-Fi supported model

Setting time/schedule

[A Type, B Type] Only Auto clean mode can be scheduled.

Setting the time

You must set the current time before using the One-time/daily schedule function.

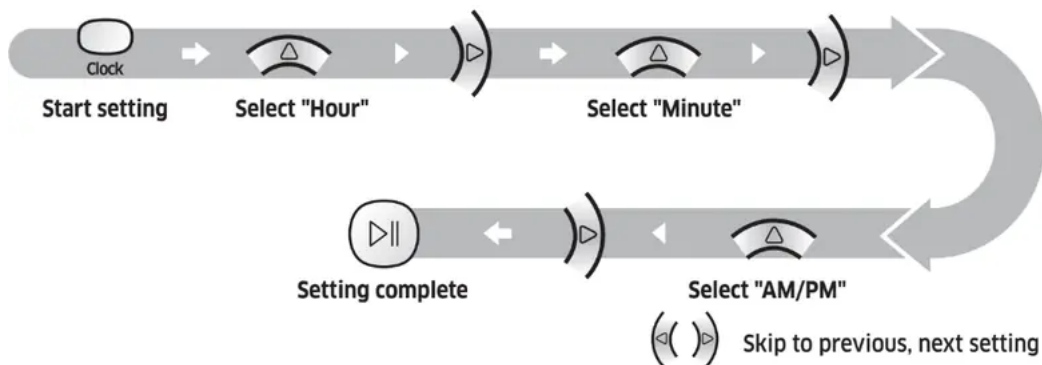

Setting the schedule

You can set/cancel the schedule only when the POWERbot is docked in the docking station.

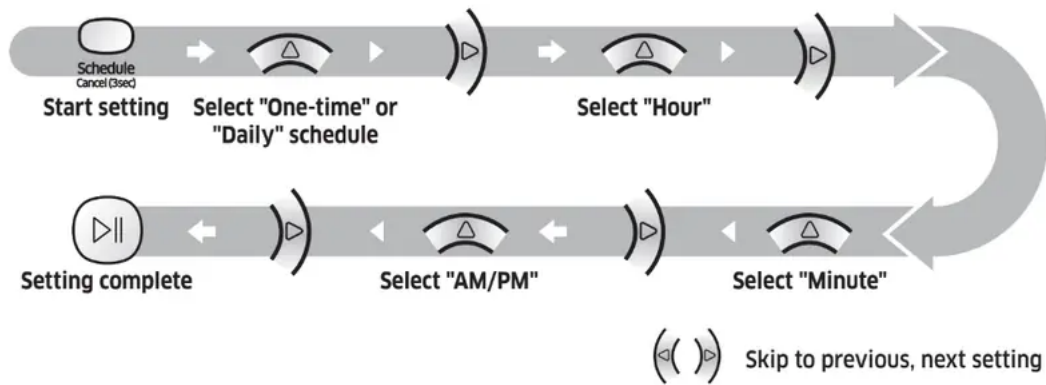

Canceling during setup

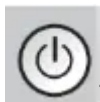

The setting will be canceled automatically if there's no input for 7 seconds

Canceling One-time/Daily schedule

When both One-time/Daily schedule is set	→ or → or
When either one of One-time or Daily schedule is set	
	Press for 3 sec.
	Select the schedule
	Cancel complete
	Press for 3 sec.

[C Type] Only Auto clean mode can be scheduled.

Setting the time

You must set the current time before using the One-time/daily schedule function.

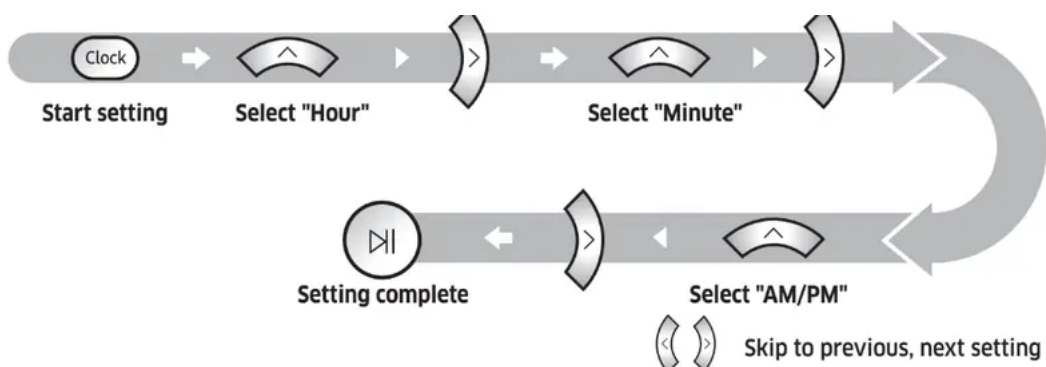

Setting the schedule

You can set/cancel the schedule only when the POWERbot is docked in the docking station.

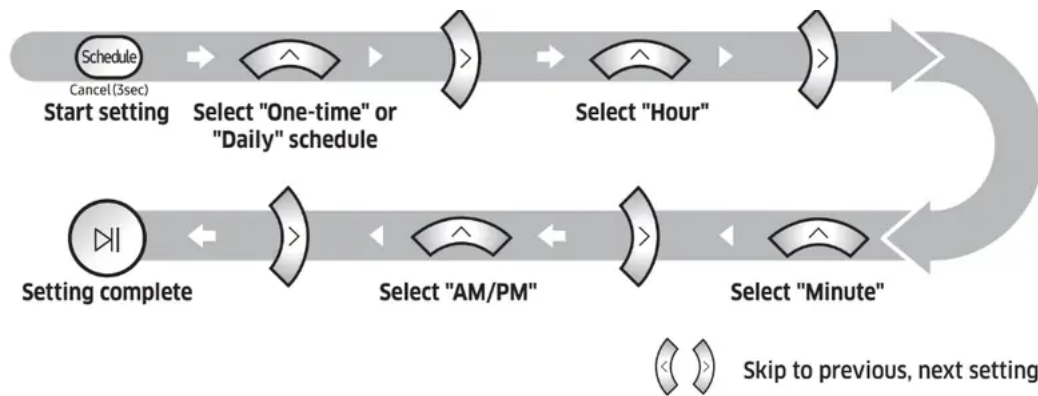

Cancelling during setup

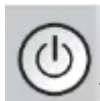

The setting will be canceled automatically if there's no input for 7 seconds

Cancelling One-time/Daily schedule

cancelling one-time/daily schedule

When both One-time/ Daily schedule is set	→ or → or
When either one of One-time or Daily schedule is set	

Press for 3 sec. Select the schedule Cancel complete

[SR1AM7010U* series] For the models which do not include a remote control, you can set a daily schedule as described below.

Setting the schedule

You can set/cancel the schedule only when the POWERbot is docked in the docking station.



Press for 3 seconds.

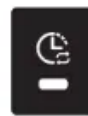

When the schedule LED is turned on, the daily schedule is set.

* The time you pressed the button will be set as the time that the POWERbot is scheduled to begin cleaning. The POWERbot will automatically begin cleaning every day at that scheduled time.





Cancelling daily schedule

When a daily schedule is set	 <p>Press for 3 seconds.</p>
------------------------------	--

Cleaning and maintaining

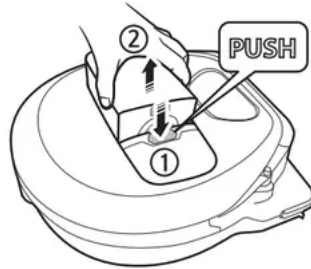
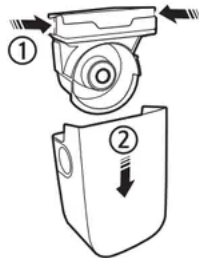

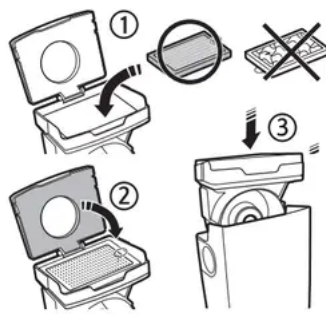
You must turn off the emergency switch before cleaning the POWERbot.

Cleaning the dustbin

 <p>1 Press the button to remove the dustbin</p>	 <p>2 Remove the dustbin cover</p>	 <p>3 Remove dust in the dustbin and cyclone unit</p>
 <p>4 Detach the cyclone unit from the dustbin cover, and then wash the dustbin and the filter</p>	 <p>5 Reassemble the dustbin</p>	 <p>6 Reinsert the dustbin into the main body until it clicks</p>

Cleaning the sensors and the camera

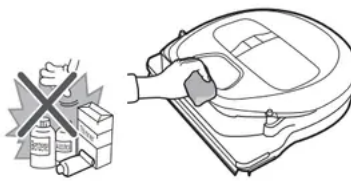
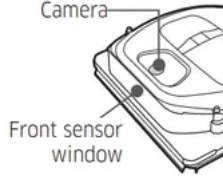
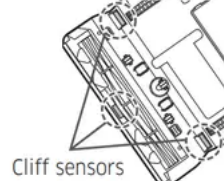
Lightly wipe with a soft cloth. Do not use water or cleaning solutions

	 <p>Camera</p> <p>Front sensor window</p>	 <p>Cliff sensors</p>	 <p>Rear sensor window</p>
---	--	---	---

Cleaning the brush and Auto shutter tool

Brush design may differ depending on the model

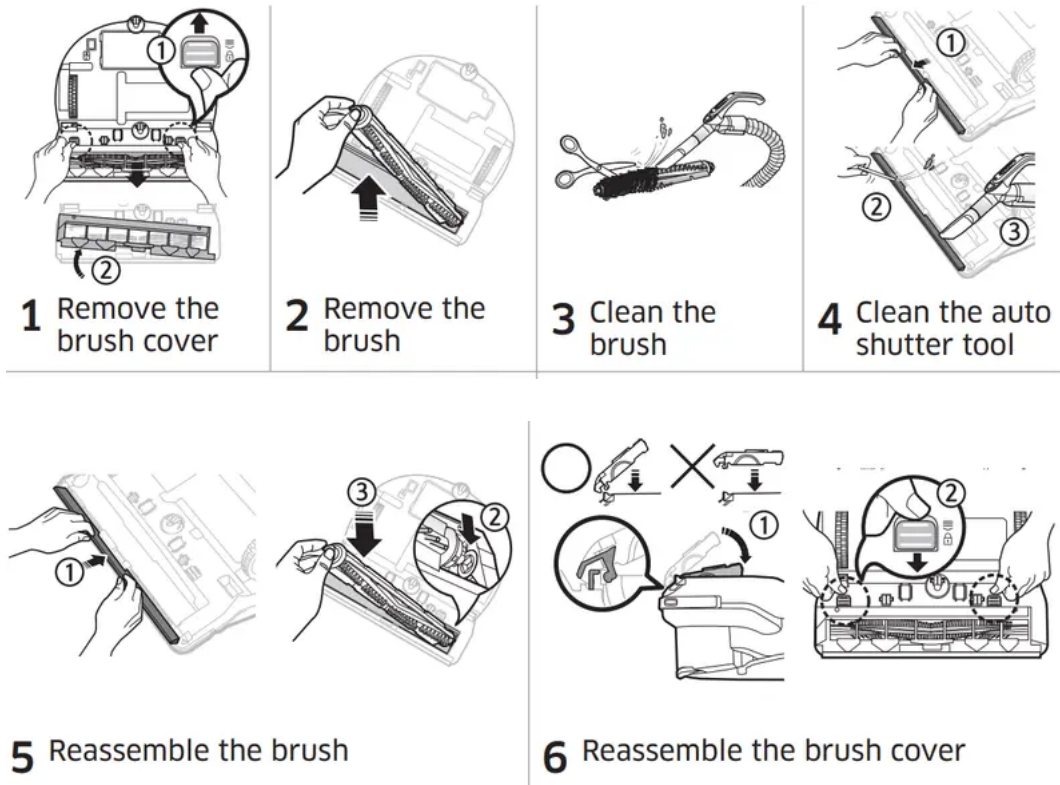

Cleaning the Driving wheel

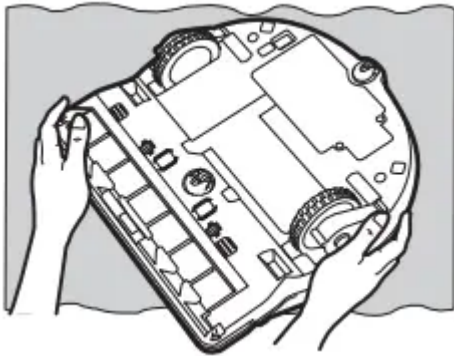

1 Put a soft cloth on the floor and place POWERbot upside-down on the cloth

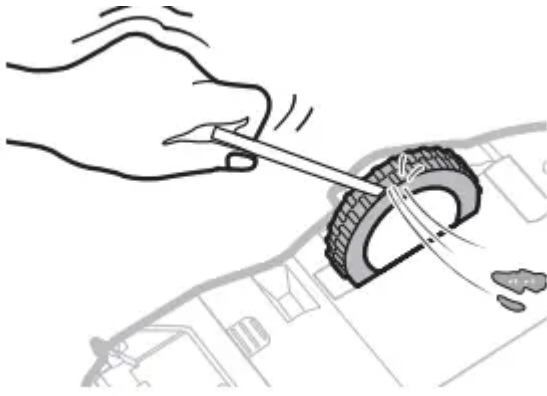

2 Use a blunt rod or tweezers to remove foreign matter.

Troubleshooting



Symptom	Checklist
<p>The POWERbot is not working at all.</p>	<p>Check if the emergency switch is on.</p> <p>Check if all the icons are displayed on the display panel.</p> <p>Check if the POWERbot's battery is depleted.</p> <ul style="list-style-type: none"> – If "Lo" is displayed, place the POWERbot in the docking station to charge it. – If the battery indicator is blinking, manually place the POWERbot in the docking station to charge. <p>(SR1AM7010U* series only) fReplace the batteries (AAA type) if the remote control is not working</p>
<p>The POWERbot has stopped during cleaning.</p>	<p>If "Lo" is displayed on the display panel, place the POWERbot in the docking station to charge it.</p> <p>If the battery indicator is blinking, manually place the POWERbot in the docking station to charge.</p> <p>(SR1AM7010U* series only)</p> <p>If the POWERbot is immobilized by an obstacle such as a cord, threshold etc, pick it up and move it away from the obstacle.</p> <ul style="list-style-type: none"> – If any fabric or string is caught in a drive wheel, turn off the emergency switch and remove the fabric or string.
<p>Suction power is weak.</p>	<p>When there's too much dust in the dustbin, suction power may be weakened. Turn off the emergency switch, and then empty the dustbin.</p> <p>If the intake (on the bottom of the POWERbot) is blocked by foreign matter, turn off the emergency switch, and then remove the foreign matter from the intake.</p> <p>When noise suddenly increases, turn off the emergency switch, and then empty the dustbin.</p>
<p>The POWERbot cannot find the docking station.</p>	<p>Check if there's a power failure or whether the power plug is unplugged.</p>

	<p>Remove any obstacles around the docking station that may prevent the POWERbot from returning to the docking station.</p> <p>If there's foreign matter on the charging pins, charging can be affected. Clean the foreign matter off the pins.</p>
The POWERbot suddenly cleans diagonally	<p>Check if the docking station is installed along the grain of a wooden or tile floor.</p> <p>The POWERbot may clean in a diagonal direction if it is moving to another area using the shortest route. It may also move at a diagonal if it made contact with an obstacles at that angle, if it was charged at the docking station at an angle, or if the grain of the wooden/tile floor is skewed in that direction.</p>
Point cleaning is not working.	<p>If you point the red light directly at the POWERbot, it may not move in desired direction. – Point the red light on the floor within 1.6 ft (0.5 m) of the POWERbot.</p> <p>* Do not use point cleaning in direct sunlight, under bright light, or on dark floors</p>
I have installed the SmartThings app, but the POWERbot fails to connect.	<p>You can use the SmartThings app with the POWERbot only after connecting the wireless router and the POWERbot through the EasySetup procedure. See pages 28 through 31.</p>
I cannot log into my Samsung account.	<p>Check your ID and password on the screen of the Samsung account</p>
A message appears saying there is a failure during Easy-Setup.	<p>You may have failed temporarily due to the distance from the wireless router or other obstacles. Please try again after a while.</p>
The SmartThings app does not work even though your smart phone is normally connected to the POWERbot.	<p>Turn off the SmartThings app and then run it again, or disconnect the smart phone from the wireless router and then connect it again. Or turn off the power supply of the POWERbot, turn it on, wait for a minute or longer, and then run the SmartThings app again.</p>
	<p>Check if the POWERbot's Smart control blocking function is On. (When Smart control is blocked, the Wi-</p>

The functions of the SmartThings App do not work.	Fi indicator is turned off. You can only use the remote control to control the POWERbot remotely.)
The SmartThings Robot Vacuum App fails to start.	Check if the POWERbot is connected to the wireless router
The POWERbot is not connected to Wi-Fi.	Check the setting status of the wireless router.
The Intelligent Power Control function works on a normal floor. (It should only work on carpets.)	<p>Check whether the floor is uneven and whether the POWERbot works with its body a bit lifted up.</p> <p>Check whether there is any foreign matter on the cliff sensor which is on the bottom of the POWERbot.</p> <p>Check whether the floor color is dark.</p>
The Intelligent Power Control function does not work.	When the POWERbot cleans a carpet with short fibers and bright color, it may recognize the carpet as a floor and then the Intelligent Power Control function may not work.
The Edge Clean Master function does not work.	<p>If the POWERbot cannot recognize a wall, the Edge clean master may not work:</p> <ul style="list-style-type: none"> – When an obstacle made of reflective material is in front of the wall – When the wall itself is made of reflective material – When the wall is a dark color
The Edge Clean Master function works though there is no wall or corner.	<p>Check whether small obstacles are arranged in a narrow space.</p> <p>If the POWERbot recognizes the front obstacle as a wall, the Edge clean master function may work</p>
The Edge Clean Master function works though the POWERbot has not approached a wall or corner.	If the degree of the angle of a corner which the POWERbot detects is large, the Edge clean master function may work even though the POWERbot has not approached the wall or corner.

<p>SmartThings App cannot be installed.</p>	<p>SmartThings App operates on Android OS 6.0 or later, iOS 10 or later.</p> <p>The supporting OS version for SmartThings App may change later.</p> <p>For rooted smart devices, standard installation and use will not be guaranteed.</p>
<p>A message of product registration failure appears.</p>	<p>Try the product registration procedure again by referring to the popup messages.</p> <p>Please refer to the "Setting up the wireless router" in the user manual.</p> <p>Please refer to the steps for completing the product registration in the user manual section "Adding a device to the SmartThings APP".</p> <p>When the product registration fails repeatedly, reset the POWERbot and Smartphone, run the SmartThings App again and try the product registration.</p> <p>The same Samsung account should be used for the login of App and product registration.</p> <p>All users should use the Samsung account issued by the same country.</p>
<p>During product registration, recharging button is pressed and held as instructed but the next step does not appear.</p>	<p>Press the recharging button until you hear it beep.</p> <p>If the next step does not appear within several seconds, press the recharging button one more time</p>
<p>During product registration, the wireless router I want to connect cannot be searched.</p>	<p>Cancel the product registration, run the SmartThings App again, and try the product registration again.</p>
<p>During product registration, the AP password 1111122222 is not input correctly.</p>	<p>Press and hold the "[robot vacuum] Samsung" on the network list and delete the network to initialize the password.</p>



<p>During product registration, the password of the connecting wireless router is not input correctly.</p>	<p>Cancel the product registration, run the SmartThings App again, and try the product registration again.</p> <p>Press and hold the wireless router you want to connect on the network list, and delete the network to initialize the password.</p>
<p>A connection cut between the SmartThings App and the POWERbot occurs though the product registration is completed.</p>	<p>Refresh the screen and wait.</p> <p>Run the SmartThings App again.</p> <p>Check whether there is an internet connection problem. Especially, a firewall may interrupt standard operation.</p>
<p>A connection cut between the SmartThings App and the POWERbot suddenly occurs during normal operation of the app.</p>	<p>If the POWERbot is distant from a wireless router, connection cut may occur.</p> <p>Reset the POWERbot and the smart phone, and check the connection again.</p> <p>If the connection cut occurs repeatedly, try the product registration again.</p> <p>When the SSID/password of a wireless router is changed, try the product registration again.</p>
<p>Controlling with SmartThings App does not work since the remote control function is disabled.</p>	<p>Remote control function is disabled status. Make the remote control function enabled status with a remote controller.</p>







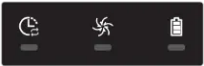

Information codes

<SR1AM7010U* series>

- 1 The three indicators below blink and an information codes alarm sounds.
- 2 Turn off the emergency switch, check the instructions below, and then take appropriate action.
- 3 The information code will disappear when you turn on the emergency switch

Information codes animation



Information codes	Checklist
	<p>The POWERbot is caught, stuck or trapped while moving. Turn off the emergency switch, and then move the POWERbot to another area.</p>
	<p>Foreign matter is caught in the brush. Turn off the emergency switch, and then remove the foreign matter from the brush.</p>
	<p>Foreign matter is caught in the left Driving wheel. Turn off the emergency switch, and then remove the foreign matter from the Driving wheel.</p>
	<p>Foreign matter is caught in the right Driving wheel. Turn off the emergency switch, and then remove the foreign matter from the Driving wheel.</p>
	<p>The bumper sensor needs to be checked. Turn off the emergency switch, and then turn it back on. If the information code does not disappear, check if there's any foreign matter between the bumper and the main body. If there is, pull the bumper slightly, and then remove the foreign matter.</p>
	<p>Foreign matter has accumulated on the obstacle sensor. Turn off the emergency switch, and then clean the front and rear sensor with a soft cloth.</p>
	<p>Foreign matter has accumulated on the cliff sensor. Turn off the emergency switch, and then clean the cliff sensor with a soft cloth.</p>
	<p>Main PCB needs to be checked. Turn off and restart the product. If the same problem occurs repeatedly, a service check is required.</p>

<SR1AM7040W* / SR2AM70**** series>

- 1 The three indicators below blink and an information codes alarm sounds.
- 2 Turn off the emergency switch, check the instructions below, and then take appropriate action.
- 3 The information code will disappear when you turn on the emergency switch

Information codes	Checklist
	<p>The POWERbot is caught, stuck or trapped while moving.</p> <p>Turn off the emergency switch, and then move the POWERbot to another area.</p>
C01	<p>Foreign matter is caught in the brush.</p> <p>Turn off the emergency switch, and then remove the foreign matter from the brush.</p>
C02	<p>Foreign matter is caught in the left Driving wheel.</p> <p>Turn off the emergency switch, and then remove the foreign matter from the Driving wheel.</p>
C03	<p>Foreign matter is caught in the right Driving wheel.</p> <p>Turn off the emergency switch, and then remove the foreign matter from the Driving wheel.</p>
C05	<p>The bumper sensor needs to be checked.</p> <p>Turn off the emergency switch, and then turn it back on.</p> <p>If the information code does not disappear, check if there's any foreign matter between the bumper and the main body. If there is, pull the bumper slightly, and then remove the foreign matter.</p>
C06	<p>Foreign matter has accumulated on the obstacle sensor.</p> <p>Turn off the emergency switch, and then clean the front and rear sensor with a soft cloth.</p>
C07	<p>Foreign matter has accumulated on the cliff sensor.</p> <p>Turn off the emergency switch, and then clean the cliff sensor with a soft cloth.</p>
C011	<p>Main PCB needs to be checked.</p> <p>Turn off and restart the product. If the same problem occurs repeatedly, a service check is required.</p>



Warning

This content is compiled from multiple sources and is provided for reference purposes only. It may not be complete or fully applicable to all situations. If you are unable to resolve your issue, please contact the product manufacturer or an authorized service provider for official support.

Document generated by [ManualsFile](#)