

REFRIGERATOR USE

Using the Controls

Using the Controls The refrigerator and freezer controls are located on the dispenser panel.

IMPORTANT: The display screen on the dispenser control panel will turn off automatically and enter “sleep” mode when the control buttons and dispenser pad have not been used for 2 minutes or more. While in “sleep” mode, the first press of a control button will only reactivate the display screen without changing any settings.

■ Touch any control button on the dispenser panel to activate the display screen. The home screen will appear as shown.

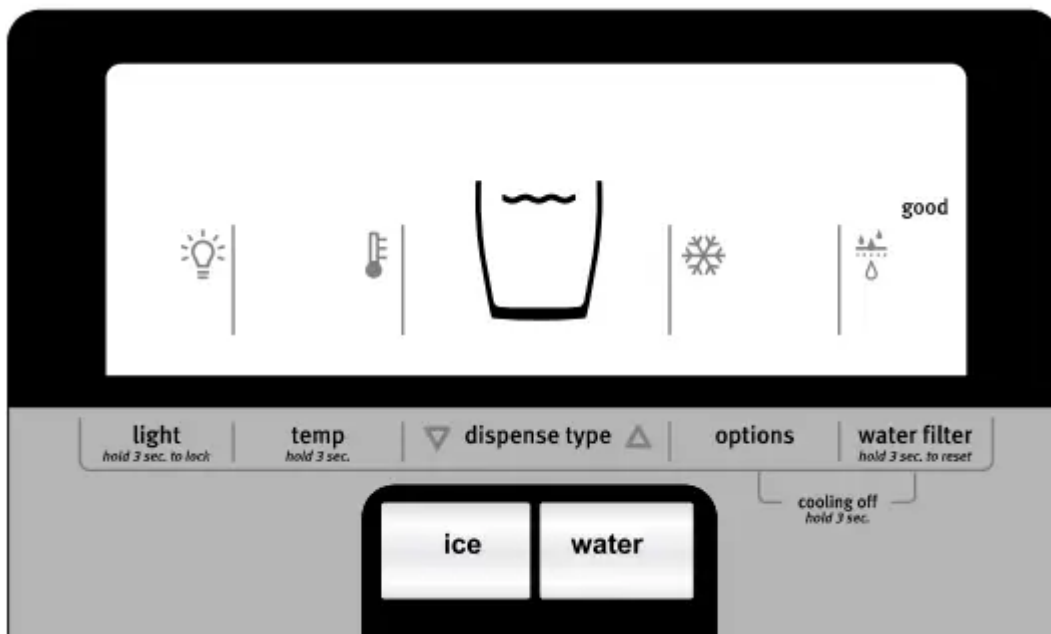

Adjusting the Controls

For your convenience, your refrigerator and freezer controls are preset at the factory. When you first install your refrigerator, make sure that the controls are still set to the “mid-settings.” The factory recommended set points are 37°F (3°C) for the refrigerator and 0°F (-18°C) for the freezer.

IMPORTANT:

■ Wait 24 hours before you put food into the refrigerator. If you add food before the refrigerator has cooled completely, your food may spoil.

NOTE: Adjusting the set points to a colder-thanrecommended setting will not cool the compartments any faster.

- If the temperature is too warm or too cold in the refrigerator or freezer, first check the air vents to be sure they are not blocked before adjusting the controls.
- The preset settings should be correct for normal household usage. The controls are set correctly when milk or juice is as cold as you like and when ice cream is firm.
- Wait at least 24 hours between adjustments. Recheck the temperatures before other adjustments are made. To view and adjust the set points, press and hold the Temp button for 3 seconds. When Adjust mode is activated, adjusting information will appear on the display screen.

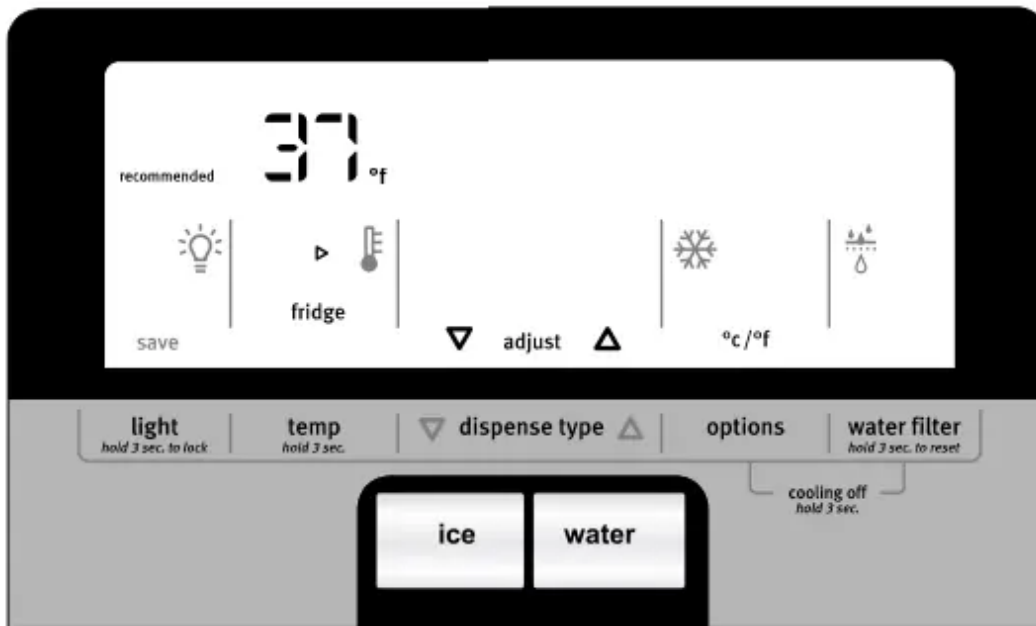

NOTE: To view Celsius temperatures, press the Options button when Adjust mode is activated. To return the display setting to Fahrenheit, press OPTIONS again.

- When Adjust mode is activated, the display screen shows the refrigerator set point and “Fridge” appears.
- Press the Dispense Type arrows to raise or lower the set point.
- When you have finished viewing (and adjusting if desired) the refrigerator set point, press TEMP to change the display to show the freezer set point. When the zone has been changed, “Freezer” appears on the display screen.
- Press the Dispense Type arrows to raise or lower the set point.
- When you have finished viewing (and adjusting if desired) both the refrigerator and freezer set points, press LIGHT to save the settings.

NOTE: To exit without saving changes, allow about 60 seconds of inactivity and Adjust mode will turn off automatically. When adjusting temperature set points, use the following chart as a guide.

When adjusting temperature set points, use the following chart as a guide.

CONDITION:	TEMPERATURE ADJUSTMENT:
REFRIGERATOR too cold	REFRIGERATOR setting 1° higher
REFRIGERATOR too warm	REFRIGERATOR setting 1° lower
FREEZER too cold	FREEZER setting 1° higher
FREEZER too warm/ Too little ice	FREEZER setting 1° lower

The set point range for the refrigerator is 33°F to 45°F (0°C to 7°C). The set point range for the freezer is -5°F to 5°F (-21°C to -15°C).

Cooling On/Off

Your refrigerator and freezer will not cool when cooling is turned off.

- To turn cooling off, press and hold OPTIONS and FILTER at the same time for 3 seconds.

IMPORTANT: To avoid unintentionally locking the dispenser or changing other settings, be sure to press both buttons at exactly the same time. When cooling is OFF, “Cooling Off” will appear on the display screen.

- Press and hold OPTIONS and FILTER for 3 seconds again to turn cooling back on.

Additional Features

Fast Ice and PowerCold®

The Fast Ice feature assists with temporary periods of heavy ice use by increasing ice production over a 24-hour period. The PowerCold® feature assists with periods of heavy ice usage, full grocery loads, or temporarily warm room temperatures.

- To turn on the Fast Ice feature, press OPTIONS. “Fast Ice” will appear on the display screen. The Fast Ice feature will remain on for 24 hours unless manually turned off.
- To turn on the PowerCold® feature, press OPTIONS a second time. The Fast Ice feature will turn off and the PowerCold® feature will turn on. “PowerCold®” will appear on the display screen. The PowerCold® feature will remain on for 24 hours unless manually turned off.
- To turn on both the Fast Ice and PowerCold® features at the same time, press OPTIONS a third time. Both “Fast Ice” and “PowerCold®” will appear on the display screen. Both features will remain on for 24 hours unless manually turned off.
- To turn both features off, press OPTIONS a fourth time. Both “Fast Ice” and “PowerCold®” will disappear from the display screen. When Fast Ice and/or PowerCold® are active, the temperature



displays will not change. After 24 hours, the refrigerator returns to the previous temperature set points.

NOTE: If increased ice production is desired at all times, change the freezer control to a lower setting. Setting the freezer to a colder temperature may make some foods, such as ice cream, harder.

Door Ajar Alarm

The Door Ajar Alarm feature sounds an alarm when the refrigerator or freezer door is open for 5 minutes and the product cooling is turned on. The alarm will repeat every 2 minutes. Close both doors to turn it off. The feature then resets and will reactivate when either door is left open again for 5 minutes.

NOTE: To mute the audible alarm while keeping the doors open, such as while cleaning the inside of the refrigerator, press any button on the control panel. The alarm sound will be temporarily turned off, but “Door Ajar” will still be displayed on the dispenser control panel.

Disabling Sounds

- To turn off all control and dispenser sounds, press and hold LIGHT and FILTER at the same time for 3 seconds.
- To turn all sounds back on, press and hold LIGHT and FILTER at the same time for 3 seconds again.

Dual Evaporator (on some models)

Some models come equipped with a dual sequential evaporation system which includes two separate evaporators for the refrigerator and freezer compartments. Dual evaporation results in higher humidity which helps keep foods in the refrigerator from spoiling as quickly and improves food quality and freshness in the freezer due to decreased freezer burn. In addition, the dual evaporation system helps keep food smells in the refrigerator from transferring to ice in the freezer.

NOTE: The dual evaporation system is always activated when your refrigerator is operating. You do not need to press any buttons to turn it on.

Water and Ice Dispensers

Flush the Water System

NOTES:

- The dispensing system will not operate when either door (refrigerator or freezer) is open.
- Allow 24 hours for the refrigerator to cool down and chill water.
- Allow 24 hours to produce the first batch of ice. Discard the first three batches of ice produced. Wait 72 hours for full ice production.

■ The display screen on the dispenser control panel will turn off automatically and enter “sleep” mode when the control buttons and dispenser pad have not been used for 2 minutes or more. While in “sleep” mode, the first press of a control button will only reactivate the display screen without changing any settings.

Flush the Water System

Air in the water dispensing system can cause the water dispenser to drip. After connecting the refrigerator to a water source or replacing the water filter, flush the water system. Flushing the water dispensing system forces air from the water line and filter and prepares the water filter for use.

NOTE: As air is cleared from the system, water may spurt out of the dispenser.

1. Using a sturdy container, depress and hold the water dispenser pad for 5 seconds, then release it for 5 seconds.
2. Repeat Step 1 until water begins to flow.
3. Once water begins to flow, continue depressing and releasing the dispenser pad (5 seconds on, 5 seconds off) until a total of 3 gal (12 L) has been dispensed. Additional flushing may be required in some households.

The Water Dispenser

IMPORTANT:

- Dispense at least 1 qt (1 L) of water every week to maintain a fresh supply.
- If the flow of water from the dispenser decreases, it could be caused by low water pressure.
 - With the water filter removed, dispense 1 cup (237 mL) of water. If 1 cup of water is dispensed in 8 seconds or less, the water pressure to the refrigerator meets the minimum requirement.
 - If it takes longer than 8 seconds to dispense 1 cup of water, the water pressure to the refrigerator is lower than recommended. See “Water Supply Requirements” or the “Problem Solver” section for suggestions.

To Dispense Water:

1. Press the Dispense Type arrows on the dispenser control panel, until “Water” is selected.
2. To dispense water, press a sturdy glass against the dispenser pad or press the Water button. Hold the glass close to the water dispenser spout to ensure that the water dispenses into the glass.

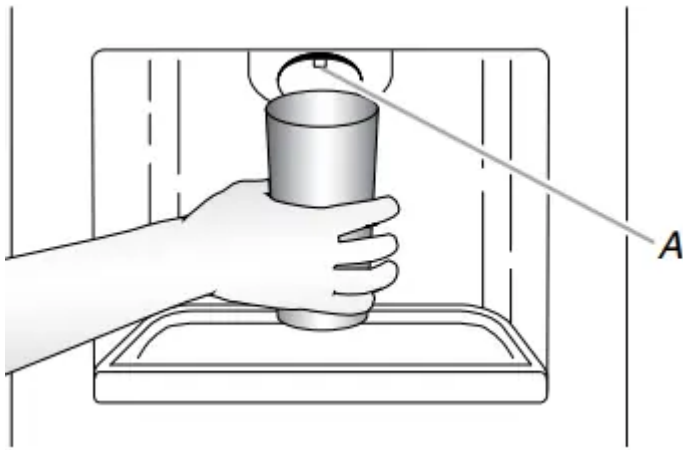

A. Water dispenser spout

3. To stop dispensing, remove the glass from the dispenser pad or release the Water button.

The Ice Dispenser

Ice dispenses from the ice maker storage bin in the freezer when the dispenser pad is pressed.

Your ice maker can produce both crushed and cubed ice. Before dispensing ice, select which type of ice you prefer by pressing the Dispense Type arrows.

The display screen indicates which type of ice is selected.

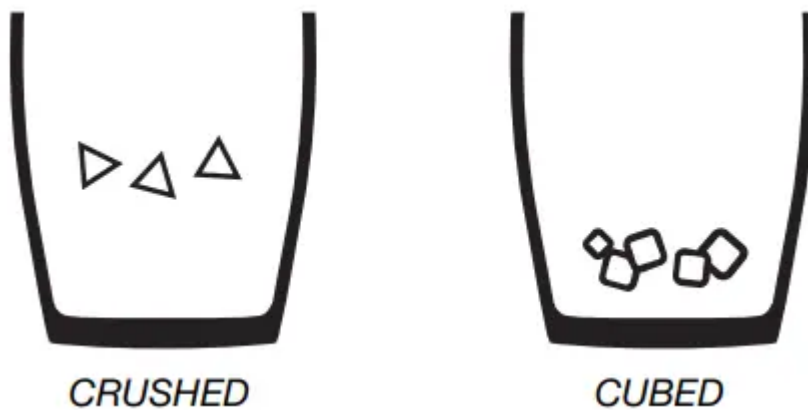

For crushed ice, cubes are crushed before being dispensed. This may cause a slight delay when dispensing crushed ice. Noise from the ice crusher is normal and pieces of ice may vary in size. When changing from crushed to cubed, a few ounces of crushed ice will be dispensed along with the first cubes.

To Dispense Ice:

1. Make sure the desired type of ice is selected. To switch between cubed and crushed, press the Dispense Type arrows.
2. To dispense ice, press a sturdy glass against the dispenser pad or press the Ice button. Hold the glass close to the ice guide to ensure that the ice dispenses into the glass.

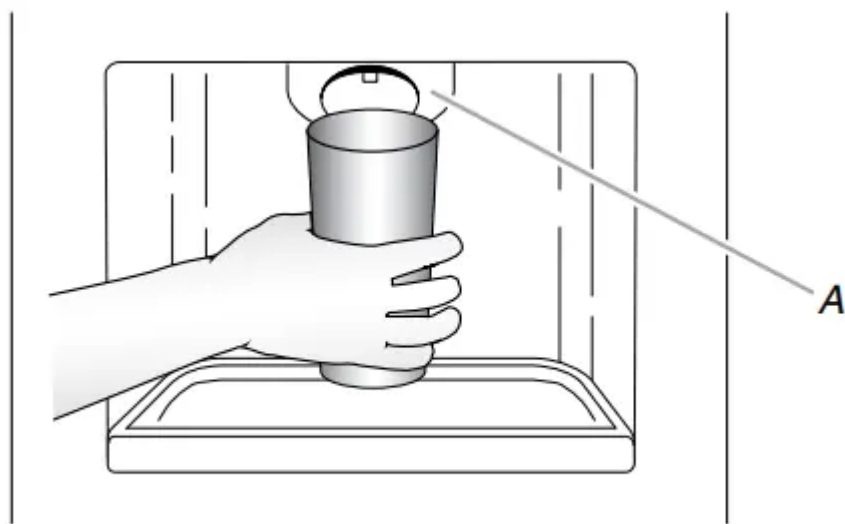

A. Ice guide

IMPORTANT: You do not need to apply a lot of pressure to the pad in order to activate the ice dispenser. Pressing hard will not make the ice dispense faster or in greater quantities.

3. To stop dispensing, remove the glass from the dispenser pad or release the Ice button.

NOTE: Ice may continue to dispense for several seconds after removing the glass from the pad. The dispenser may continue to make noise for a few seconds after dispensing.

The Dispenser Light

When you use the dispenser, the light will automatically turn on. If you want the light to be on continuously, you may choose either ON or DIM.

- ON: Press LIGHT to turn the dispenser light on. "On" will appear on the display screen.
- DIM: Press LIGHT a second time to select DIM mode. "Dim" will appear on the display screen. The dispenser light will remain on, but at a lower intensity.
- OFF: Press LIGHT a third time to turn the dispenser light off.

The dispenser lights are LEDs that cannot be changed. If it appears that your dispenser lights are not working, see the "Problem Solver" section for more information.

The Dispenser Lock

The dispenser can be turned off for easy cleaning or to avoid unintentional dispensing by small children and pets.

NOTE: The lock feature does not shut off power to the refrigerator, to the ice maker, or to the dispenser light. It simply deactivates the controls and dispenser pad. T

- Press and hold LIGHT for 3 seconds to lock the dispenser. "Dispenser Locked" will appear on the display screen.
- Press and hold LIGHT a second time to unlock the dispenser

Ice Maker and Storage Bin

- Allow 24 hours to produce the first batch of ice. Discard the first three batches of ice produced.
- The quality of your ice will be only as good as the quality of the water supplied to your ice maker. Avoid connecting the ice maker to a softened water supply. Water softener chemicals (such as salt) can damage parts of the ice maker and lead to poor quality ice. If a softened water supply cannot be avoided, make sure the water softener is operating properly and is well maintained.
- Do not use anything sharp to break up the ice in the storage bin. This can cause damage to the ice container and the dispenser mechanism.
- Do not store anything on top of or in the ice maker or storage bin.

Style 1

Turning the Ice Maker On/Off:

The On/Off switch, located on the left wall of the freezer door, can only be accessed when the ice storage bin has been removed. See the following section for bin removal instructions.

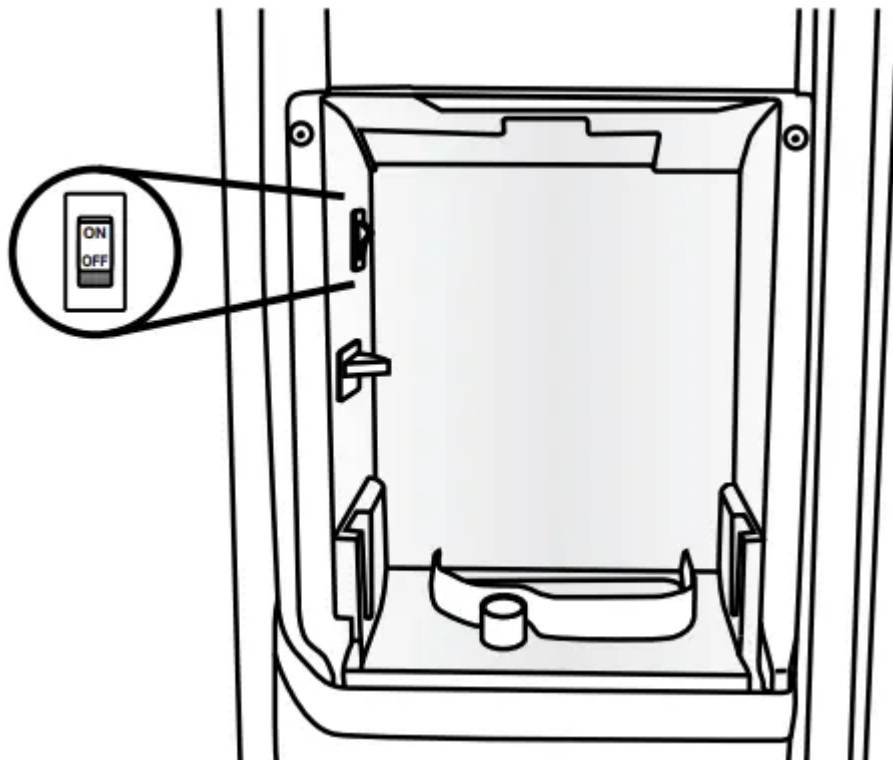

- To turn on the ice maker, flip the switch to the on (up) position.
- To manually turn off the ice maker, flip the switch to the off (down) position.

NOTE: The ice maker has an automatic shutoff to keep the storage bin from overflowing during normal operation. As ice is made, the ice cubes will fill the ice storage bin, and the ice cubes will raise the shut-off arm to the off (arm up) position. When the storage bin is at full capacity, the ice

maker will automatically stop ice production, but the ice maker On/Off switch will remain in the on (up) position.

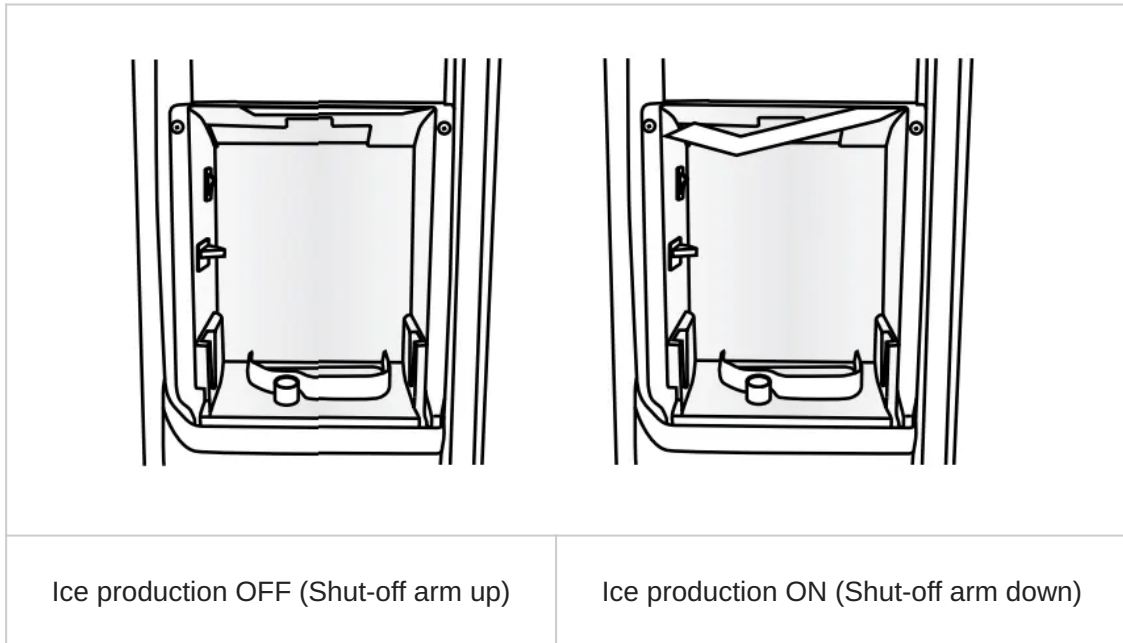

Removing and Replacing the Ice Storage Bin:

1. Press the release lever down and tilt the bucket outward. Use both hands to hold the base of the storage bin, then lift it up and out.

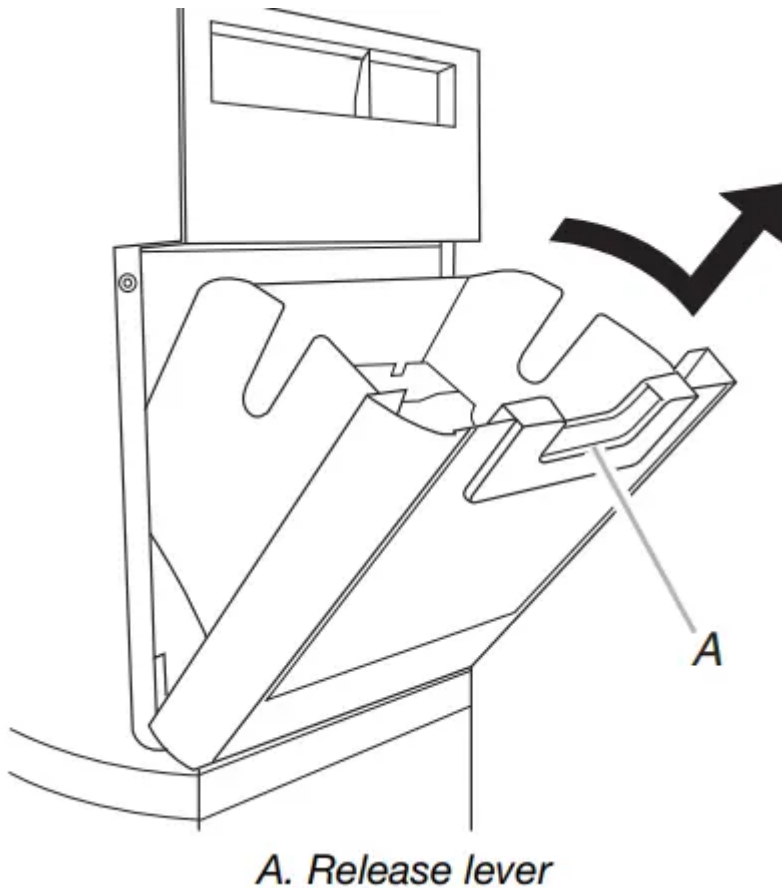

NOTE: It is not necessary to flip the ice maker On/Off switch to the off (down) position when removing the storage bin. The storage bin sensor, located on the left wall of the freezer door, stops the ice maker from producing ice if the door is open or the storage bin is removed.

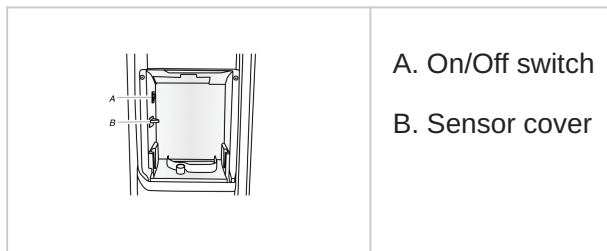

2. Replace the bin by sliding it onto the door, then tilting it back into an upright position. The release lever will click when the bin is securely in place.

Style 2

Turning the Ice Maker On/Off:

- To turn on the ice maker, simply lower the wire shut-off arm.
- To manually turn off the ice maker, lift the wire shut-off arm to the Off (arm up) position and listen for the click. Ice can still be dispensed, but no more can be made.

NOTE: The ice maker has an automatic shutoff to keep the storage bin from overflowing during normal operation. As ice is made, the ice cubes will fill the ice storage bin and the ice cubes will raise the wire shut-off arm to the OFF (arm up) position. Do not force the wire shut-off arm up or down.

Removing and Replacing the Ice Storage Bin:

1. Pull the covering panel up from the bottom.
2. Lift the wire shut-off arm so it clicks into the Off (up) position.
3. Lift up the front of the storage bin and pull it out.

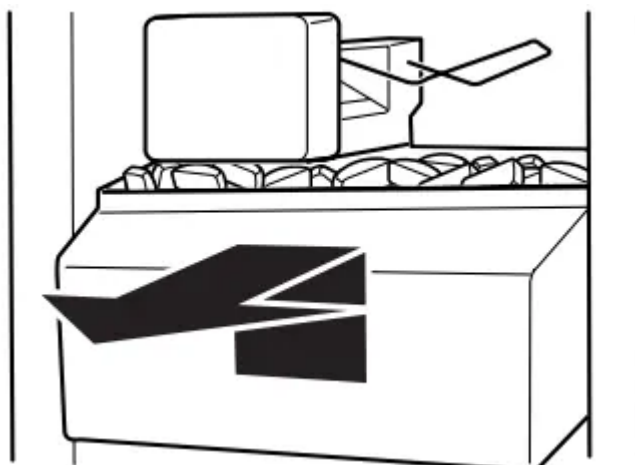

4. Replace the bin by pushing it in all the way or the dispenser will not work.

5. To restart ice production, lower the wire shut-off arm into

Water Filtration System

Do not use with water that is microbiologically unsafe or of unknown quality without adequate disinfection before or after the system. Systems certified for cyst reduction may be used on disinfected waters that may contain filterable cysts.

Water Filter Status Light

The water filter status light will help you know when to change your water filter.

- When the dispenser control panel's water filter status display changes to "ORDER," this tells you that it is almost time to change the water filter cartridge.
- Replace the water filter cartridge when the water filter status display changes to "REPLACE."

NOTE: If water flow to your water dispenser or ice maker decreases noticeably, change the filter sooner. The filter should be replaced at least every 6 months, depending on your water quality and usage.

Resetting the Filter Status

- After changing the water filter, reset the status light by pressing and holding the Filter button for 3 seconds. When the system is reset, the "ORDER" and "REPLACE" icons will disappear from the display screen.

Changing the Water Filter

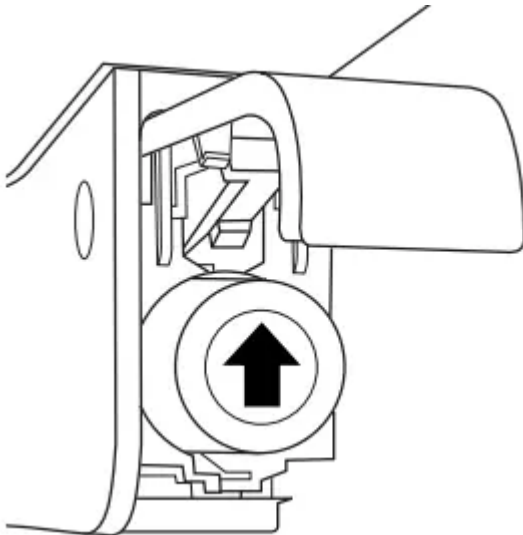

1. Locate the water filter in the top-right corner of the refrigerator compartment.
2. Lift open the filter cover door. The filter will be released and then be ejected as the door is opened.
3. When the door is completely open, pull the filter straight out.

NOTE: There may be some water in the filter. Some spilling may occur. Use a towel to wipe up any spills.

4. Take the new filter out of its packaging and remove the cap. Be sure the O-rings are still in place after the cap is removed.

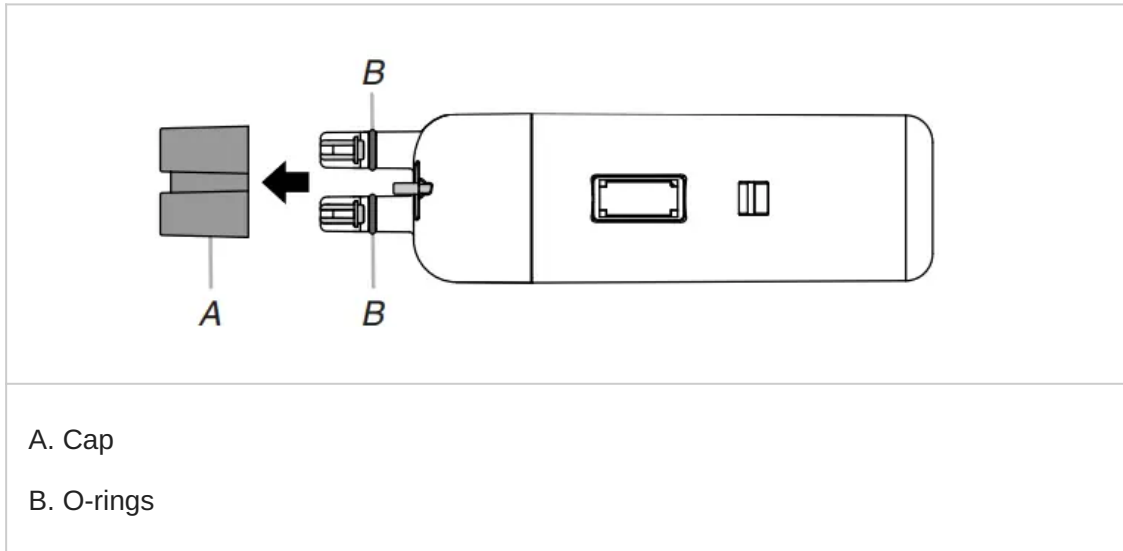

5. With the arrow pointing up, align the new filter with the filter housing and slide it into place. The filter cover door will automatically begin to close as the new filter is inserted.

6. Close the filter cover door completely in order to snap the filter into place. You may need to press hard.

7. Flush the water system.

REFRIGERATOR CARE

Cleaning

Both the refrigerator and freezer sections defrost automatically. However, clean both sections about once a month to avoid buildup of odors. Wipe up spills immediately.

IMPORTANT: Because air circulates between both sections, any odors formed in one section will transfer to the other. You must thoroughly clean both sections to eliminate odors. To avoid odor transfer and drying out of food, wrap or cover foods tightly.

Clean Your Refrigerator:

NOTE: Do not use abrasive or harsh cleaners such as window sprays, scouring cleansers, flammable fluids, cleaning waxes, concentrated detergents, bleaches, or cleansers containing petroleum products on plastic parts, interior and door liners or gaskets. Do not use paper towels, scouring pads, or other harsh cleaning tools. Stainless steel models has coating, Do Not Use regular stainless steel cleaning products. Do Not Use stainless steel Cleaner or Polish and use only mild soap, water, and soft microfiber cloth to avoid damage to the stainless steel protective

coating. Paper towels scratch and may dull the clear coat of the painted door. To avoid possible damage, use only clean cloths to polish and wipe the door.

1 Unplug refrigerator or disconnect power.

2 Hand wash, rinse, and dry removable parts and interior surfaces thoroughly. Use a clean sponge or soft cloth and a mild detergent in warm water.

3 Wash stainless steel and painted metal exteriors with a clean sponge or soft cloth and a mild detergent in warm water.

4 There is no need for routine condenser cleaning in normal home operating environments. If the environment is particularly greasy or dusty, or there is significant pet traffic in the home, the condenser should be cleaned every 2 to months to ensure maximum efficiency.

If you need to clean the condenser:

- Remove the base grille. See the “Door Removal” instructions, either in the User Instructions or the
- Installation Instructions and Owner’s Manual or in the separate instruction sheet provided with your refrigerator.
- Use a vacuum cleaner with a soft brush to clean the grille, the open areas behind the grille, and the front surface area of the condenser.
- Replace the base grille when finished.



5 Plug in refrigerator or reconnect power.

Lights

IMPORTANT: The light bulbs in both the refrigerator and freezer compartments of your new refrigerator may use LED technology. If the lights do not illuminate when the refrigerator and/or freezer door is opened, call for assistance or service.

Light Styles:

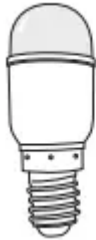
The dispenser lights are mini LEDs that cannot be changed. The interior lights vary by model. ■
Some models have mini LEDs that cannot be changed.

	
Whirlpool Part Number W10574850A (2.0 watts)	Whirlpool Part Number W10565137A (3.6 watts)

NOTE:

- Some LED replacement bulbs are not recommended for wet/damp environments. The refrigerator and freezer compartments are considered to be wet/damp environments. If using a brand of LED bulb other than the recommended Whirlpool LED bulb, read and follow all instructions on the replacement bulb's packaging before installing it.
- Some models have incandescent 40-watt bulbs that can be changed.

NOTE: Not all replacement bulbs will fit your refrigerator. Do not use an incandescent bulb in excess of 40 watts.
--

To Change a Light Bulb:

1. Unplug refrigerator or disconnect power.
 2. Remove the light shield, as explained in the following sections.
- NOTE: To clean the light shield wash it with warm water and liquid detergent. Before reinstalling, thoroughly rinse and dry the shield.
3. Replace the burned-out light bulb as explained in the following sections.
 4. Reinstall the light shield as explained in the following sections.
 5. Plug in refrigerator or reconnect power

Refrigerator Compartment - Upper Lights

Light Shield Removal:

- Slide the light shield toward the rear of the refrigerator and remove it from the light housing.



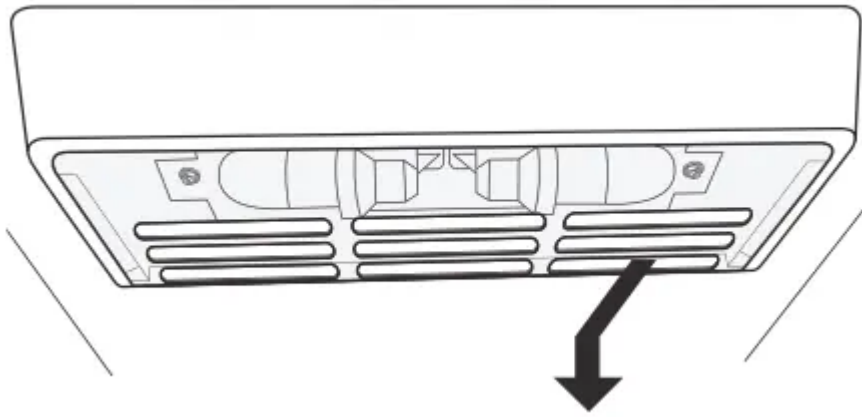

Replacement Bulb:

- If the burned-out light is a full-size LED bulb, replace it with Whirlpool part number W10574850A (a 2.0-watt LED bulb).
- If the burned-out light is an incandescent bulb, replace it with an incandescent appliance bulb of the same size, shape, and wattage (40-watt maximum).

Light Shield Reinstallation:

- Align the light shield in the grooves at the bottom edge of the light housing, then slide it forward until it snaps into place.

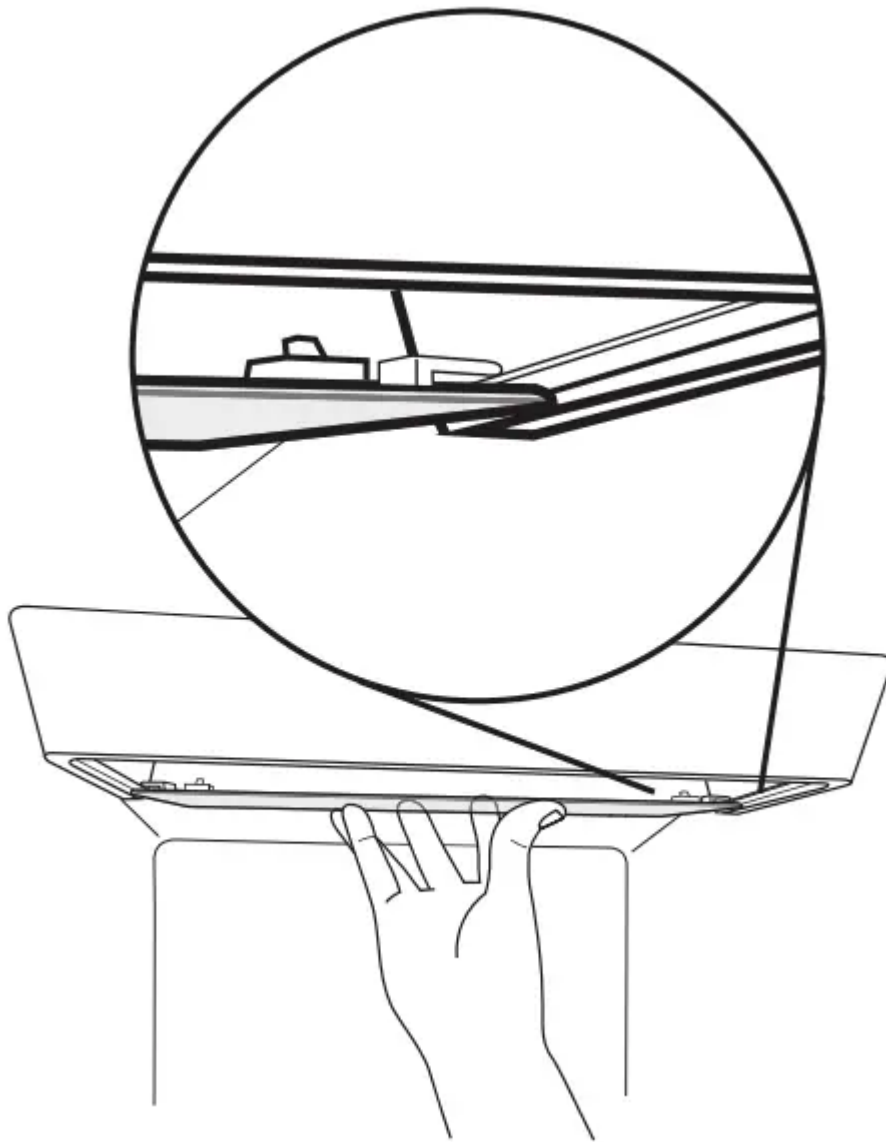

Refrigerator Compartment - Lower Lights

Light Shield Removal:

- Slide the light shield to the right to remove the left end from the wall slots, then pull the right end out of its wall slots.

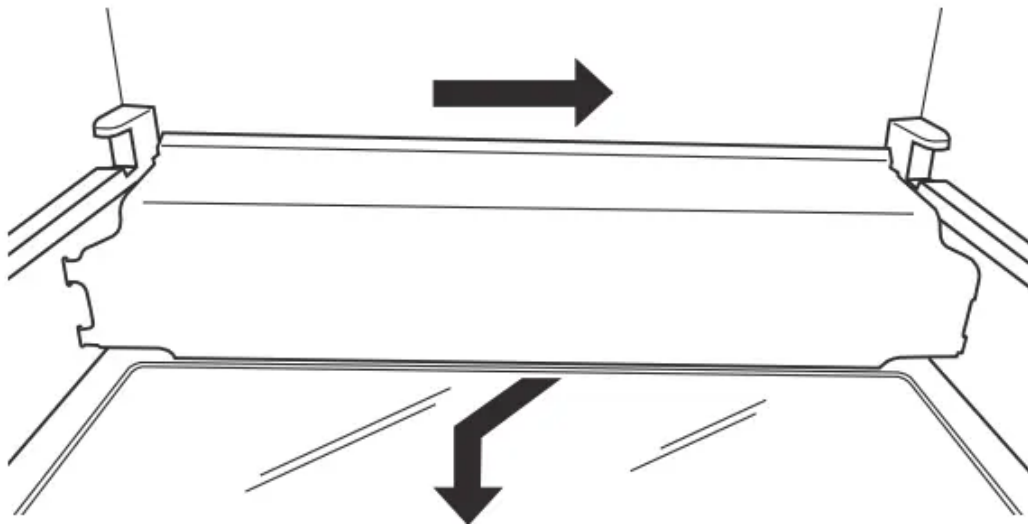

Replacement Bulb:

- If the burned-out light is a full-size LED bulb, replace it with Whirlpool part number W10565137A (a 3.6-watt LED bulb).
- If the burned-out light is an incandescent bulb, replace it with an incandescent appliance bulb of the same size, shape, and wattage (40-watt maximum).

Light Shield Reinstallation:

- Place the right end of the light shield into the wall slots, then snap the left end into its wall slots.

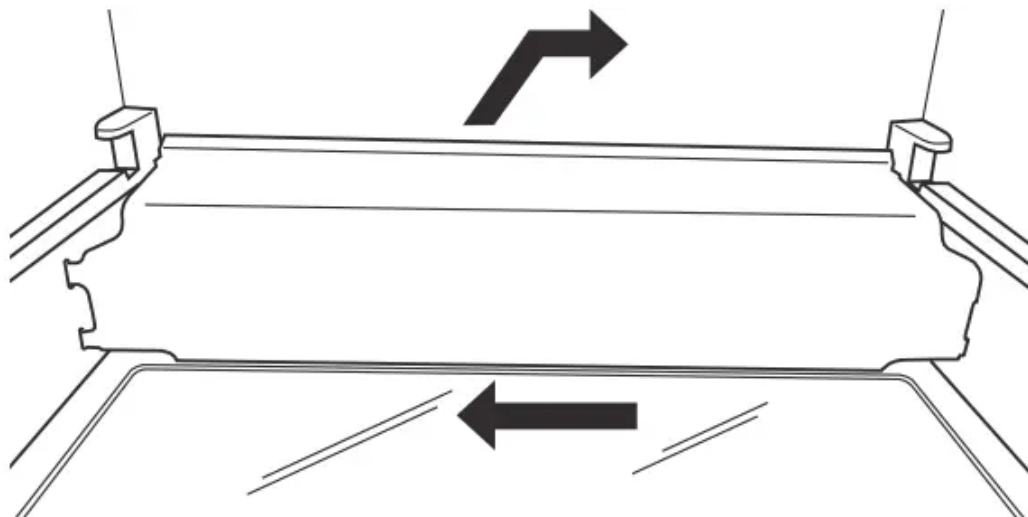

Freezer Compartment - Upper Light

Light Shield Removal:

- Gently squeeze the front and bottom-rear edges of the light shield to release the tabs from the wall slots, then pull the light shield forward.

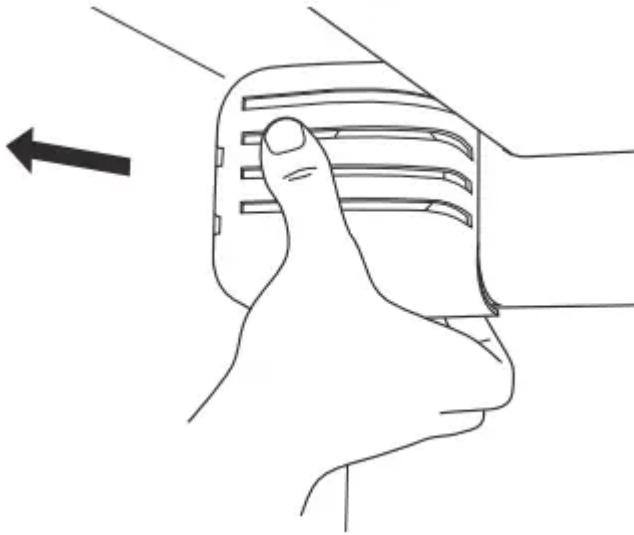

Replacement Bulb:

- If the burned-out light is a full-size LED bulb, replace it with Whirlpool part number W10565137A (a 3.6-watt LED bulb).
- If the burned-out light is an incandescent bulb, replace it with an incandescent appliance bulb of the same size, shape, and wattage (40-watt maximum).

Light Shield Reinstallation:

- Align the light shield in its proper position and snap the tabs into the wall slots.

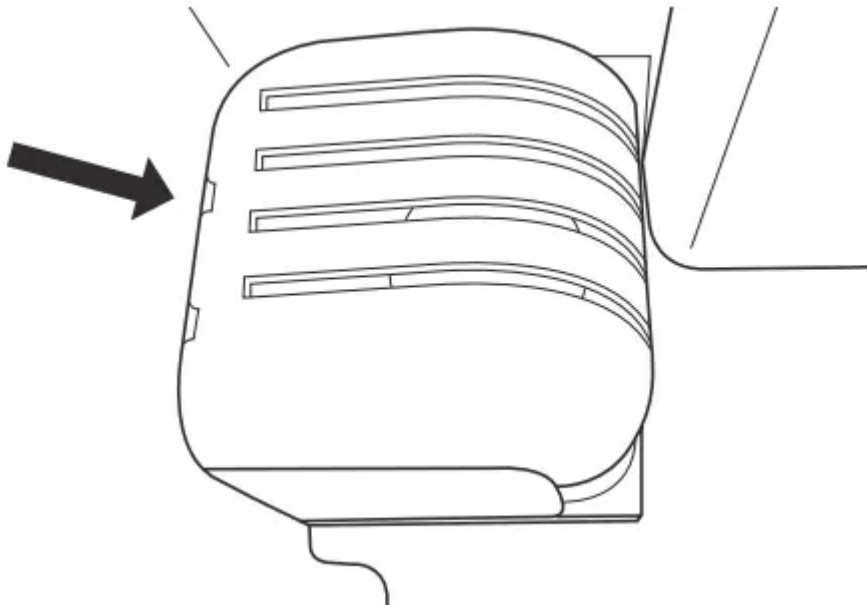

Freezer Compartment - Lower Light

Light Shield Removal:

- Slide the light shield to the left to remove the right end from the wall slots, then pull the left end out of its wall slots.

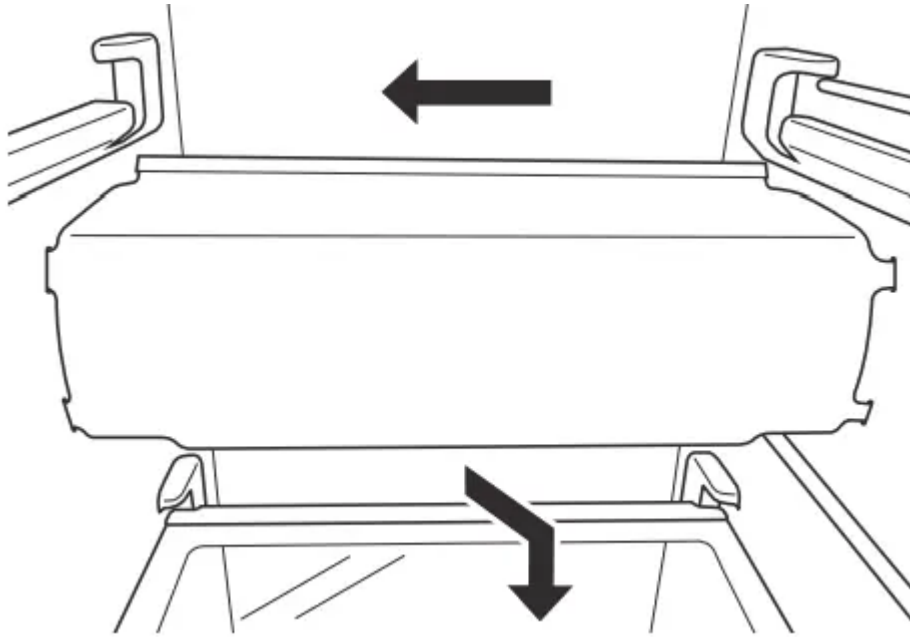

Replacement Bulb:

- If the burned-out light is a full-size LED bulb, replace it with Whirlpool part number W10565137A (a 3.6-watt LED bulb).
- If the burned-out light is an incandescent bulb, replace it with an incandescent appliance bulb of the same size, shape, and wattage (40-watt maximum).

Light Shield Reinstallation:

- Place the left end of the light shield into the wall slots, then snap the right end into its wall slots.

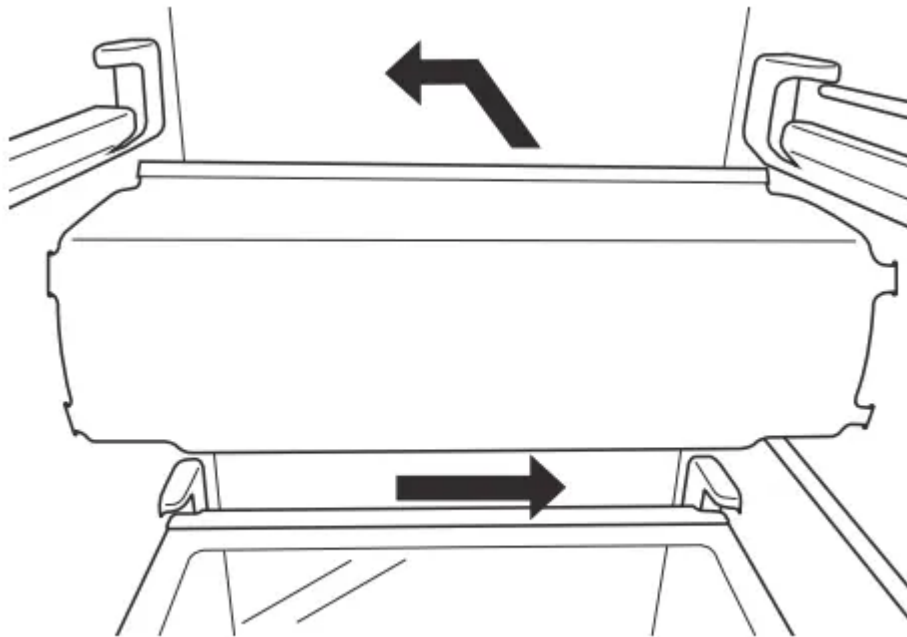

Vacation and Moving Care

Vacations

If You Choose to Leave Refrigerator On While You Are Away:

1. Use up any perishables and freeze other items.
2. If your refrigerator has an automatic ice maker and is connected to the household water supply, turn off the water supply to the refrigerator. Property damage can occur if the water supply is not turned off.
3. If you have an automatic ice maker, turn off the ice maker. NOTE: Depending on your model, raise the wire shut-off arm to Off (up) position or press the switch to OFF.
4. Empty the ice bin.

If You Choose to Turn Refrigerator Off Before You Leave:

1. Remove all food from the refrigerator.
2. If your refrigerator has an automatic ice maker:
 - Turn off the water supply to the ice maker at least one day ahead of time.
 - When the last load of ice drops, raise the wire shutoff arm to the Off (up) position or move the switch to OFF.
3. Depending on the model, turn the Refrigerator Control to OFF or turn cooling off.
4. Clean, wipe, and dry thoroughly.
5. Tape rubber or wood blocks to the tops of both doors to prop them open far enough for air to get in. This stops odor and mold from building up

Moving

When you are moving your refrigerator to a new home, follow these steps to prepare it for the move.

1. If your refrigerator has an automatic ice maker:
 - Turn off the water supply to the ice maker at least one day ahead of time.
 - Disconnect the water line from the back of the refrigerator.
 - When the last load of ice drops, raise the wire shut-off arm to the Off (up) position or move the switch to OFF.
2. Remove all food from the refrigerator and pack all frozen food in dry ice.
3. Empty the ice bin.
4. Depending on the model, turn the Refrigerator Control to OFF or turn cooling off. See “Using the Controls” in the User Instructions, User Guide, or Use & Care Guide.
5. Unplug refrigerator.

6. Clean, wipe, and dry thoroughly.
7. Take out all removable parts, wrap them well, and tape them together so they don't shift and rattle during the move.
8. Depending on the model, raise the front of the refrigerator so it rolls more easily OR screw in the leveling legs so they don't scrape the floor. See "Adjust the Doors" or "Door Removal, Leveling, and Alignment."
9. Tape the doors closed and tape the power cord to the back of the refrigerator.

When you get to your new home, put everything back and refer to the Installation Instructions for preparation instructions. Also, if your refrigerator has an automatic ice maker, remember to reconnect the water supply to the refrigerator.

TROUBLESHOOTING



GENERAL OPERATION	Possible Causes and/or Recommended Solutions
Refrigerator will not operate	<ul style="list-style-type: none"> ■ Not connected to an electrical supply - Plug the power cord into a grounded 3 prong outlet. Do not use an extension cord. ■ No power to the electrical outlet - Plug in a lamp to see if the outlet is working. ■ Household fuse has blown or circuit breaker has tripped - Replace the fuse or reset the circuit breaker. If the problem continues, contact a licensed electrician. ■ Control or cooling is not turned on - Turn on the refrigerator control or turn cooling on. See "Using the Controls." ■ New installation - Following installation, allow 24 hours for the refrigerator and freezer to cool completely. <p>NOTE: Adjusting the temperature control(s) to the coldest setting(s) will not cool either compartment (refrigerator or freezer) more quickly.</p>
Motor seems to run too much	<ul style="list-style-type: none"> ■ Your new refrigerator has an energy efficient motor - The refrigerator may run longer than you're used to because the compressor and fans operate at lower speeds that are more energy efficient. This is normal. <p>NOTE: Your refrigerator may run even longer if the room is warm, a large load of food is added, the doors are opened often, or if a door has been left open.</p>
Refrigerator seems noisy	<p>Refrigerator seems noisy The compressor in your new refrigerator regulates temperature more efficiently and uses less energy than older models. During various stages of operation, you may hear normal operating sounds that are unfamiliar.</p> <p>The following noises are normal:</p> <ul style="list-style-type: none"> ■ Buzzing/Clicking - Heard when the water valve opens and closes to dispense water or fill the ice maker. If the refrigerator is connected to a water line, this is normal. If the refrigerator is not connected to a water line, turn off the ice maker. ■ Cracking/Crashing - Heard when ice is ejected from the ice maker mold.



GENERAL OPERATION	Possible Causes and/or Recommended Solutions
	<ul style="list-style-type: none"> ■ Popping - Heard when the inside walls contract/expand, especially during initial cool down. ■ Pulsating/Whirring - Heard when the fans/compressor adjust to optimize performance during normal operation. ■ Rattling - Heard when water passes through the water line or due to the flow of refrigerant. Rattling may also come from items placed on top of the refrigerator. ■ Water running or gurgling - Heard when ice melts during the defrost cycle and water runs into the drain pan. ■ Sizzling - Heard when water drips onto the heater during the Defrost cycle.
<p>Refrigerator rocks and is not stable</p>	<ul style="list-style-type: none"> ■ Refrigerator is not level - To stabilize the refrigerator, remove the base grille and lower the leveling feet until they touch the floor. See the “Door Removal, Leveling, and Alignment.”
<p>Ice maker is not producing ice, not producing enough ice, or producing small/hollow ice</p>	<ul style="list-style-type: none"> ■ Refrigerator is not connected to a water supply or the water supply shut-off valve is not fully turned on - Connect the refrigerator to a water supply and make sure the water shutoff valve is fully open. ■ Kink in the water source line - A kink in the water line can reduce water flow, resulting in decreased ice production, small ice cubes, and/or hollow or irregularly shaped ice. Straighten the water line. ■ Ice maker is not turned on - Turn on the ice maker. See “Ice Maker and Storage Bin.” ■ New installation - After connecting the refrigerator to a water source, flush the water system. (See “Water and Ice Dispensers.”) Wait 24 hours for ice production to begin. Wait 72 hours for full ice production. Discard the first three batches of ice produced. ■ Large amount of ice was recently removed - Allow sufficient time for the ice maker to produce more ice. ■ Ice is jammed in the ice maker ejector arm (on some models) - Remove ice from the ejector arm using a plastic utensil. ■ Inadequate water pressure - Verify that the household has adequate water pressure. See “Water Supply Requirements.”



GENERAL OPERATION	Possible Causes and/or Recommended Solutions
	<ul style="list-style-type: none"> ■ Water filter is installed incorrectly - Make sure the filter is properly installed. See “Water Filtration System.” ■ A reverse osmosis water filtration system is connected to your cold water supply - This can decrease water pressure. See “Water Supply Requirements.” <p>NOTE: If questions remain regarding water pressure, contact a licensed, qualified plumber.</p>
Ice dispenser will not operate properly	<ul style="list-style-type: none"> ■ Doors not closed completely - Make sure both doors are firmly closed. (On some models, only the freezer door must be closed in order to operate the dispenser.) ■ New installation - After connecting the refrigerator to a water source, flush the water system. (See “Water and Ice Dispensers.”) Wait 24 hours for ice production to begin. Wait 72 hours for full ice production. Discard the first three batches of ice produced. ■ Ice maker is not turned on or ice bin is not installed correctly - Turn on the ice maker and make sure the ice storage bin is firmly in position. See “Ice Maker and Storage Bin.” ■ Ice is clogged or frozen together in the ice storage bin or ice is blocking the ice delivery chute - Remove or separate the clogged ice, using a plastic utensil if necessary. Clean the ice delivery chute and the bottom of the ice storage bin using a warm damp cloth, then dry both thoroughly. To avoid clogging and to maintain a fresh supply of ice, empty the storage bin and clean both the storage bin and the delivery chute every 2 weeks. ■ Wrong ice has been added to the storage bin - Use only ice cubes produced by the current ice maker. ■ Dispenser is locked - Unlock the dispenser. See “Water and Ice Dispensers.” ■ Ice dispenser jams while dispensing crushed ice - For models with the ice storage bin on the door, temporarily switch from crushed ice to cubed ice to clear the jam. ■ Dispenser pad/lever has been pressed too long - Ice will automatically stop dispensing. Wait a few minutes for the dispenser to

GENERAL OPERATION	Possible Causes and/or Recommended Solutions
	<p>reset, then resume dispensing. Take large amounts of ice directly from the ice bin, not through the dispenser.</p> <ul style="list-style-type: none"> ■ Water pressure to the home is not at or above 30 psi (207 kPa) - The water pressure to the home affects the flow from the dispenser. See “Water Supply Requirements.” ■ Water filter is clogged or incorrectly installed - Replace filter or reinstall it correctly. See “Water Filtration System.”
Ice or water has an off-taste, odor, or gray color	<ul style="list-style-type: none"> ■ New plumbing connections - New plumbing connections can result in off-flavored or discolored ice or water. This problem should go away over time. ■ Ice has been stored too long - Discard the ice and wash the ice bin. Allow 24 hours for the ice maker to produce new ice. ■ Odor has transferred from food - Use airtight moisture-proof packaging to store food. ■ Use of non-recommended water supply line - Odors and tastes can transfer from certain materials used in non-recommended water supply lines. Use only a recommended water supply line. See “Water Supply Requirements.” ■ There are minerals (such as sulfur) in the water - A water filter may need to be installed in order to remove the minerals. ■ Water filter was recently installed or replaced - Gray or dark discoloration in ice or water indicates that the water filtration system needs additional flushing. See “Water and Ice Dispensers.”
	<ul style="list-style-type: none"> ■ Doors not closed completely - Make sure both doors are firmly closed. (On some models, only the freezer door must be closed in order to operate the dispenser.) ■ Refrigerator is not connected to a water supply or the water supply shut-off valve is not turned on - Connect the refrigerator to a water supply and make sure the water shut-off valve is fully open. ■ Kink in the water source line - A kink in the water line can reduce water flow to the dispenser. Straighten the water line.



GENERAL OPERATION	Possible Causes and/or Recommended Solutions
	<ul style="list-style-type: none"> ■ Water pressure to the home is not at or above 30 psi (207 kPa) - The water pressure to the home affects the flow from the dispenser. See “Water Supply Requirements.” ■ New installation - After connecting the refrigerator to a water source, flush the water system. See “Water and Ice Dispensers.” ■ Dispenser is locked - Unlock the dispenser. See “Water and Ice Dispensers.” ■ Water filter is clogged or incorrectly installed - Replace filter or reinstall it correctly. See “Water Filtration System.” ■ A reverse osmosis water filtration system is connected to your cold water supply - This can decrease water pressure. See “Water Supply Requirements.” <p>NOTE: If questions remain regarding water pressure, contact a licensed, qualified plumber.</p>
<p>Water is leaking or dripping from the dispenser</p>	<p>NOTE: After dispensing, a few additional drops of water are normal.</p> <ul style="list-style-type: none"> ■ Glass was not held under the dispenser long enough - Hold the glass under the dispenser for 2 to 3 seconds after releasing the dispenser pad/lever. ■ New installation or water filter was recently installed or replaced - Air in the water lines causes the water dispenser to drip. Flush the water system to remove the air in the water lines. See “Water and Ice Dispensers.” ■ Residual ice in the dispenser chute is melting - Make sure the ice chute is free of ice shavings or pieces.
<p>Water is leaking from the back of the refrigerator</p>	<p>Water line connections are not fully tightened - Make sure all connections are firmly tightened. See “Connect Water Supply.”</p> <p>refrigerator</p>
<p>Water from the dispenser is not cool enough (on some models)</p>	<p>NOTE: Water from the dispenser is chilled to 50°F (10°C).</p> <ul style="list-style-type: none"> ■ New installation - Allow 24 hours after installation for the water supply to cool completely.



GENERAL OPERATION	Possible Causes and/or Recommended Solutions
	<ul style="list-style-type: none"> ■ Recently dispensed a large amount of water - Allow 24 hours for the new water supply to cool completely. ■ Water has not been recently dispensed - The first glass of water may not be cool. Discard the first glass of water dispensed. ■ Refrigerator is not connected to a cold water pipe - Make sure the refrigerator is connected to a cold water pipe. See “Water Supply Requirements.”

Warning

This content is compiled from multiple sources and is provided for reference purposes only. It may not be complete or fully applicable to all situations. If you are unable to resolve your issue, please contact the product manufacturer or an authorized service provider for official support.

