

General Maintenance

Your Billi B-5000 has been designed to require minimal maintenance other than replacement of filter cartridges. During each filter change, check all water connection fittings for signs of leakage. Check all tubing for any signs of damage. Check the cupboard area around the base of unit for any signs of moisture. Ensure side vents of the under bench module are kept clear and airflow is not obstructed. Restricted airflow will cause inefficient operation of the refrigeration system.

—Cleaning the dispenser

Your Billi B-5000 Dispenser is fabricated from solid zinc casting material with tough protective chrome plating. Proper care of the Billi Electronic dispenser crucial; Avoid using abrasive cleaners. Wipe clean using a damp cloth. Use of a non-solvent, non-smearing cleaner such as Windex is recommended. Do not pour water over dispenser.

Cupboard ventilation requirements

Your Billi B-5000 underbench module requires minimal cupboard ventilation and requires air space around the unit of 100mm. Care should be taken when using the cupboard space, to avoid stretching or damaging plastic pipe work. Check fittings and tubing at each filter change for signs of damage or leakage. Always ensure access to power switch and water supply tap is not restricted.

Features and Modes

Dispenser Swivel

The B-5000 dispenser incorporates a swivel function, allowing the dispenser to be swung out of the way if more sink space is required. A central position stop provides positive location during normal usage.

Safety Timeout

Your Billi B-5000 incorporates a water delivery Safety Timeout to prevent an uncontrolled flow of water. Water flow stops automatically after a set time interval. Flow can be started again by releasing and pressing the dispenser lever or buttons.

Boiling water timeout – 10 secs;

Chilled water – 1 minute.

Childproof safety switch

Your Billi B-5000 is fitted with a childproof safety lock-out feature to protect against accidental dispensing of boiling water and the risk of burns. Please refer to safety switch settings on page 5.

Self learning timer (EcoIntelligence)

Your Billi B-5000 incorporates an energy saving self learning timer. This timer learns the users behaviour over a period of time (up to one month) and pre-empts the need for water throughout each 24-hour period over a week. Data is lost when the power is removed however learnings from the first days use is applied to the entire learning cycle so the unit will quickly resume intelligent timer operation. When the self-learning timer is enabled the unit will enter standby if no water is expected to be used for a 3 hour or more period. The unit will shutdown completely if no water is expected to be used for a 6 hour or more period. In office environments this feature will typically cause the unit to turn off outside normal business hours, ie: overnight and on weekends. In domestic environments with no one home during working hours the unit will turn off through each weekday but may remain on at night and during weekends. See page 6 for dispenser icons. To activate, refer to Options, page 5.

Standby Mode

Standby operation may be optionally enabled to reduce power consumption. In standby mode the hot water set point is reduced to 72°C and the cold water set point is increased to 18°C. When enabled, standby is invoked after two hours from the time of last use. When a tap lever or button is pressed in standby no water is dispensed. The indicators will flash to indicate the water is not ready. The lever or button can be repressed to dispense water. During Standby mode the moon & star icon will flash. See page 6 for dispenser icons. To activate, refer to Options, page 5.

Boiling water disabled mode

Your Billi B-5000 features an additional boiling water safety isolation feature. Once activated, delivery of boiling water becomes totally disabled. Chilled water can be dispensed normally.

During this mode, the red, hot, icon will remain off. To activate, refer to Options & Operation, Safety Switch Settings, page 5.

Holiday mode

Holiday Mode is provided to save energy when the unit will not be used for long periods. In this mode both the water chiller and water heater are disabled and the unit will use very little power. Pressing the Pressure Relief button places the unit in Holiday Mode. The unit will exit Holiday Mode if either the power is turned off then on or if any of the levers are pressed. The Self Learning Timer will ignore user behaviour while the unit is in Holiday Mode and resume normal operation when the mode is terminated. Holiday Mode is indicated by the star & moon icon being illuminated. See page 6 for icon images.

Options and Operation

To operate, simply press the left lever to dispense boiling water and the right lever to dispense chilled. When lifted the levers will latch for continual delivery, until released with a light press.

Operating modes can be selected by the user by entering Options Mode.

Within the options mode, you can set the safety switch through the hot water lever and power save mode through the cold water lever.

To enter the options mode:

1. Turn on the unit and wait for normal operation (red & blue icons are both illuminated constantly).
2. Push both the hot and cold levers down & then while holding the two levers down touch the safety switch indent at the back of the black panel. Hold both levers and safety switch for 3 seconds.
3. Icons will flash yellow.
4. Release both the levers & safety switch.
5. Unit is now in options mode.
6. If you wish to change or set the safety switch mode, follow the safety switch settings procedure below. If you wish to change or activate the power saving mode follow the power save mode settings procedure below.

Safety Switch settings

The Red padlock indicates the different safety settings enabled. To change or activate a setting once in options mode as above, press and release the hot (left) lever to scroll through the following options;

- Red Icon Off: indicates the hot tap is disabled.
- Padlock icon on, Red icon on: indicates safety switch is enabled
- Red Icon On: indicates normal operation with safety switch not enabled.

To save new setting and exit Options Mode, touch the safety switch and release. Wait 10 seconds for unit to return to normal operation, with the desired settings.

To dispense boiling water once the safety switch is activated simply touch the indent on the black panel, at the back of the tap. You will be able to dispense boiling water for 8 seconds. After 8 seconds the safety switch will automatically reactivate, and the red padlock icon will appear again.

Power save mode settings (EcoIntelligence, standby or on 24/7)

The Green icons on the tap indicate the power save level that is selected. To change or activate a setting once in options mode press and release the cold(right) lever to scroll through the following options;

- Green Leaf icon: indicates Eco Intelligence self learning timer is enabled.
- Moon & Star Icon on: indicates Standby Mode is enabled.
- Blue Icon On, no green icons: indicates system is in 24 hour continuous mode

To save new setting and exit Options Mode, press the safety switch and release. Wait 10 seconds for unit to return to normal operation, with the desired settings.

Holiday mode

To set press the pressure relief valve located under the unit cover beside the filter housing.

To operate, simple press the red (left) button to dispense boiling water, and blue (right) button to dispense chilled filtered water. When the red or blue lights are double tapped, the water will dispense continually until interrupted by another light press of either blue or red buttons.

Operating modes can be selected by the user by entering option mode. Within the options mode, you can set the safety switch thorough the red button (left) and power save mode through the blue button (right)

To enter the options mode:

Turn on the unit and wait for normal operation (red and blue buttons are both illuminated constantly)

Press both the red and blue buttons. While pressing the two buttons, touch the red lock icon located in the middle and towards the back of the lens. Press and hold both red and blue buttons and safety switch for three seconds.

Icons will flash yellow.

Release the safety switch and buttons.

Unit is now in options mode.

If you wish to change or activate the power saving mode, follow the power save mode settings procedure below.

Safety Switch settings

The Red padlock indicates the different safety settings enabled. To change or activate a setting once in options mode as above, press and release the red (left) button to scroll through the following options;

- Red Icon Off: indicates the hot tap is disabled.

- Padlock icon on, Red icon on: indicates safety switch is enabled
- Red Icon On: indicates normal operation with safety switch not enabled.

To save new setting and exit Options Mode, touch the safety switch and release. Wait 10 seconds for unit to return to normal operation, with the desired settings.

To dispense boiling water once the safety switch is activated simply touch the red lock icon on the top of the lens. You will be able to dispense boiling water for 8 seconds. After 8 seconds the safety switch will automatically reactivate, and the red padlock icon will appear again.

Power save mode settings (EcoIntelligence, standby or on 24/7)

The Green icons on the tap indicate the power save level that is selected. To change or activate a setting once in options mode press and release the blue (right) button to scroll through the following options;

- Green Leaf icon: indicates Eco Intelligence self learning timer is enabled.
- Moon & Star Icon on: indicates Standby Mode is enabled.
- Blue Icon On, no green icons: indicates system is in 24 hour continuous mode

To save new setting and exit Options Mode, press the safety switch and release. Wait 10 seconds for unit to return to normal operation, with the desired settings.

Holiday mode

To set press the pressure relief valve located under the unit cover beside the filter housing.

Dispenser Icon



Orange dot.

Flashes when filter change due. On constant when overdue.

Red lock illuminated.

Safety button activated. To use, press the indent on the back of the tap momentarily & lift or press the boiling lever.

Green leaf illuminated.

Eco intelligence.

Green moon & stars illuminated.

In holiday mode. Red & blue icons will not be displayed in this mode.

Green moon & stars flashing

In standby mode. Red & blue icons will not be displayed in this mode.

Red dot.

Flashes when heating up to temperature. On constant when boiling water ready. Off when in holiday or standby mode.

Blue dot.

Flashes when chilling. On constant when chilled water ready. Off when in holiday or standby mode.
Red & blue dots will flash yellow if the unit goes into fault.

Dispenser Icon codes



Dispenser Icon



Orange dot.

Flashes when filter change due. On constant when overdue.

Red lock illuminated.

Safety button activated. To use, press the red lock icon on the top of the tap momentarily & press the red button (left).

Green leaf illuminated.

Eco intelligence.

Green moon & stars illuminated.

In holiday mode. Red & blue icons will not be displayed in this mode.

Green moon & stars flashing

In standby mode. Red & blue icons will not be displayed in this mode.

Red ring.

Flashes when heating up to temperature. On constant when boiling water ready. Off when in holiday or standby mode.

Blue ring.

Flashes when chilling. On constant when chilled water ready. Off when in holiday or standby mode.
Red & blue rings will flash yellow if the unit goes into fault.

Dispenser Icon codes

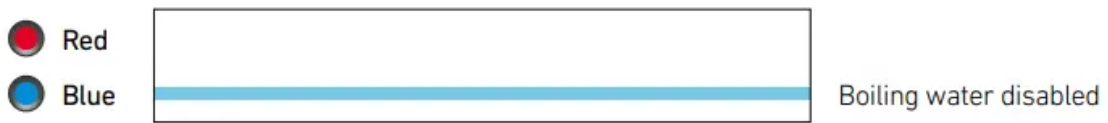
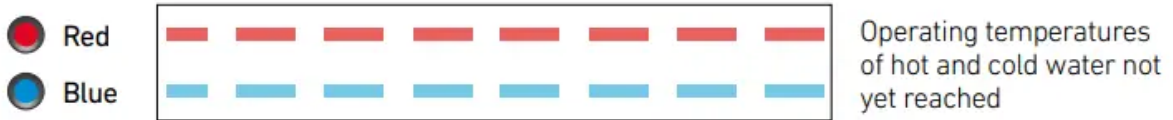

Dispenser Icon



Orange dot.

Flashes when filter change due. On constant when overdue.

Red lock illuminated.

Safety button activated. To use, press the red lock icon on the top of the tap momentarily & press the red button (left).

Green leaf illuminated.

Eco intelligence.

Green moon & stars illuminated.

In holiday mode. Red & blue icons will not be displayed in this mode.

Green moon & stars flashing

In standby mode. Red & blue icons will not be displayed in this mode.

Red ring.

Flashes when heating up to temperature. On constant when boiling water ready. Off when in holiday or standby mode.

Blue ring.

Flashes when chilling. On constant when chilled water ready. Off when in holiday or standby mode. Red & blue rings will flash yellow if the unit goes into fault.

Dispenser Icon codes

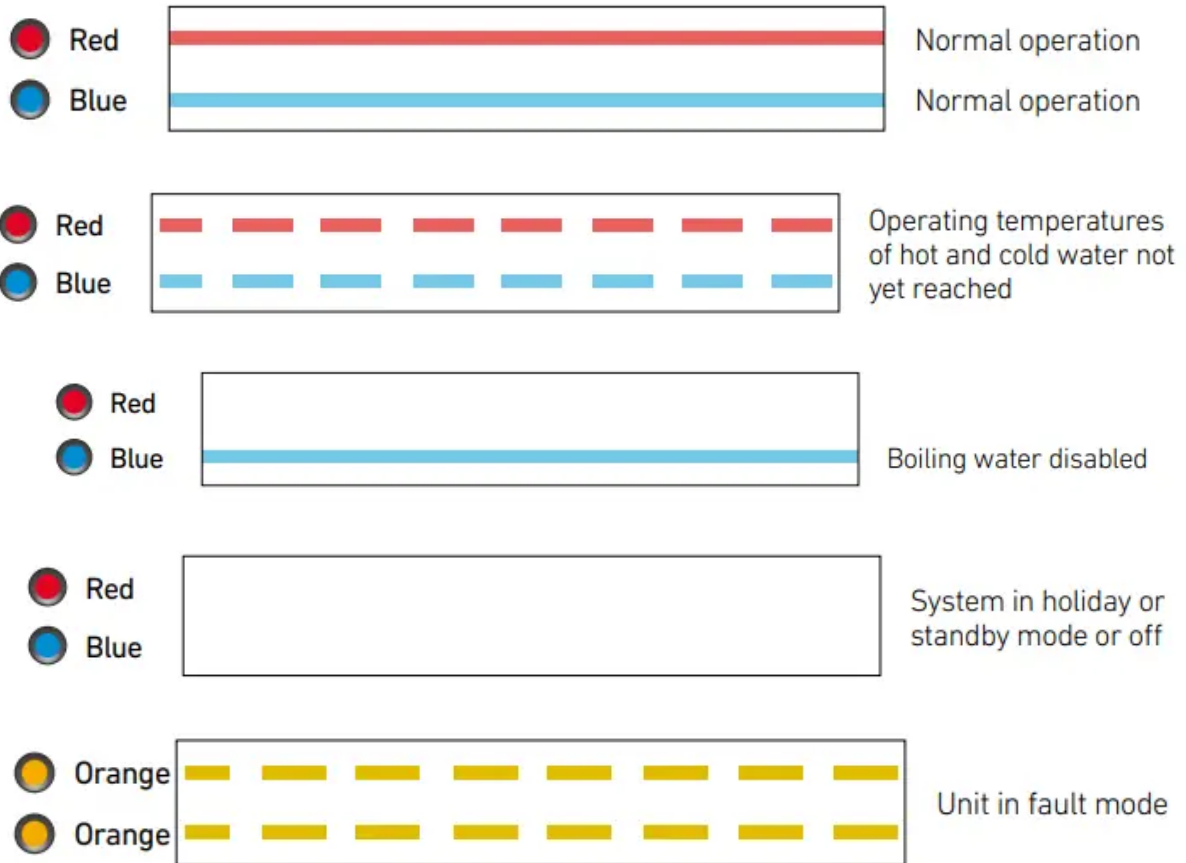

Billi Filter Cartridges

The Billi B-5000 features the Billi swingchange filtration system. The B-5000 is fitted with a single filter. The filters use Fibredyne™ technology which is fibrous and matted together, increasing the surface area of the carbon, meaning there is greater contact time and improved quality of filtration. It incorporates five stage filtration, removing sediment and chemical elements as well as enabling minerals to flow through the appliance without allowing scale build up and arresting the growth of bacterial microorganisms such as giardia and cryptosporidium. Use only genuine filters as designed for this system. All drinking water filtration systems should be flushed after a period of non-use.

Replacement of Billi Filter Cartridge

Periodic replacement of your Billi B-5000 filter cartridge is necessary to maintain the sparkling cleanliness and purity of your drinking water. A replacement filter change service is available. To arrange, contact the Billi Service centre on 1800 812 321. If you wish to install the replacement

filter cartridges yourself, filters can be purchased online at www.billi.com.au or through a certified agent which will provide genuine Billi replacement filter cartridge sets.

Filter Change Due Monitor

The B-5000 filter change due monitor operates by counting the number of cups dispensed and the number of days elapsed until a pre-set level is reached. Once reached, the yellow filter icon as pictured above will turn on. The B-5000 will continue to operate while the filter indicator is flashing. Water filters installed in areas with higher levels of sediment will experience a reduced service life. It may be necessary to change filters before the change filter indicator flashes. If particularly dirty water is noticed coming through the water supply, e.g. from other tap ware, immediately place your Billi B-5000 into Holiday Mode by pressing the Pressure Relief button. This will help prevent premature blocking of the filter cartridges.

Billi Filter Cartridges – Reduces & Removal

Filter Type	Order Part No.	Suits	Micr.	Filters	Sediment	Chlorine	VOCs	Chemicals	Taste Odour	Fluoride Minerals	Expected Life
Prem.	994002	Billi B-5000	0.2	Single	✓	✓	✓	✓	✓	Slight	6 - 12 months
Stand.	994001	Billi B-5000	5.0	Single	✓	✓	✗	✓	✓	✗	6 - 12 months

Filter removal and replacement instructions

Important note: Please ensure you remove the foam packing under the filter before installing.

1. Remove the front panel.
2. Place the unit in Holiday Mode by pressing the Pressure Relief button once. The lights on the dispenser will alternate and then go off
3. Hold filter and swing towards you slowly. The top of the filter is in a hinged cradle assembly. It should stop after approximately 30 degrees of travel.
4. The filter can now be released from the holding cradle by pulling down on the filter.
5. Take care not to spill water in the base of the tray. If so wipe gently with absorbent paper.
6. Install new filter into the same location by pushing all the way up into the cradle.
7. Push filter back into the unit until it locks into place. Power light should come back on.
8. Flush chilled side until water flow stops. Wait 10 minutes. Repeat these steps 2 times.
9. Check for any leaks from around the filter, hosing or pipeworks.
10. Replace the front cover.

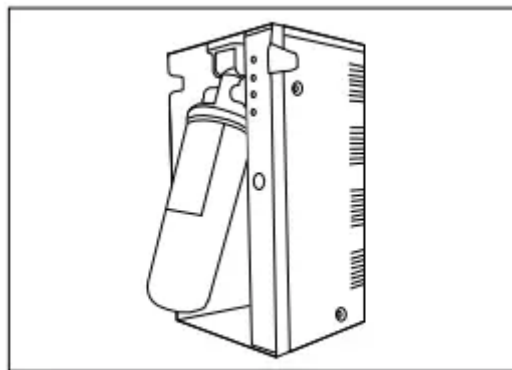
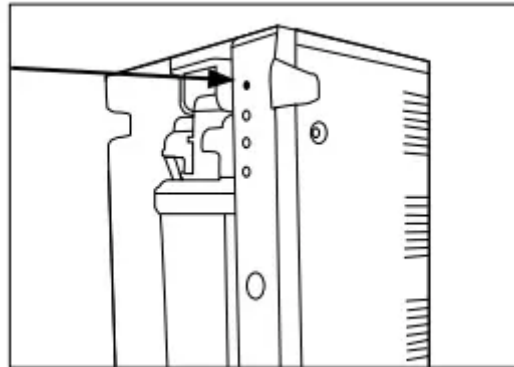
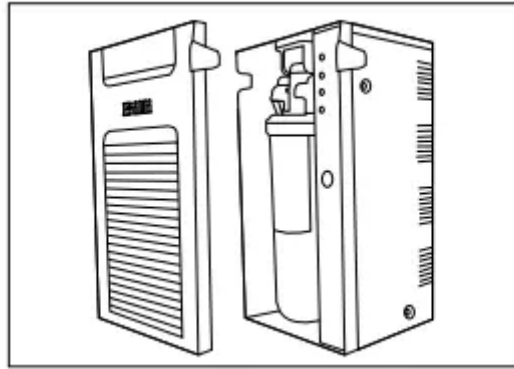

Warning

This content is compiled from multiple sources and is provided for reference purposes only. It may not be complete or fully applicable to all situations. If you are unable to resolve your issue, please contact the product manufacturer or an authorized service provider for official support.