

Installation

What's included

Make sure all parts and accessories are included in the product package. If you have a problem with the oven or accessories, contact a local Samsung customer center or your retailer.

Oven at a glance

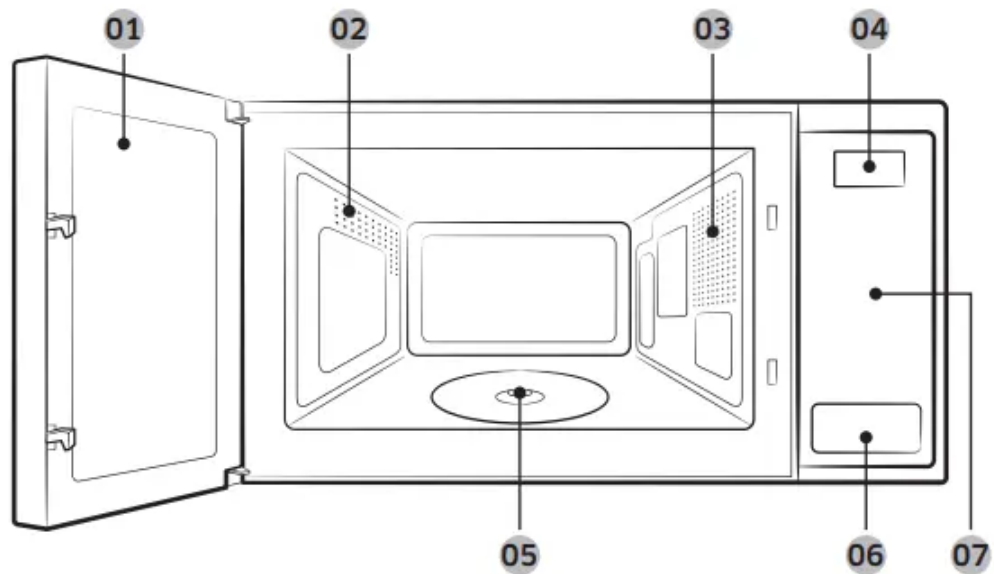

- 01 Door
- 02 Vent
- 03 Oven light
- 04 Display
- 05 Coupler
- 06 Push button door opener
- 07 Feature pane

Accessories

The oven comes with different accessories that help you prepare different types of food.



Roller ring : Put in the center of the base. It supports the turntable.

Turntable : Put on the roller ring with the center fitting the coupler on the microwave's floor. It serves as a cooking base.

NOTE :Do not operate the oven without the turntable on the roller ring

Turntable

Remove all packing materials inside the oven. Install the roller ring and turntable. Check that the turntable rotates freely

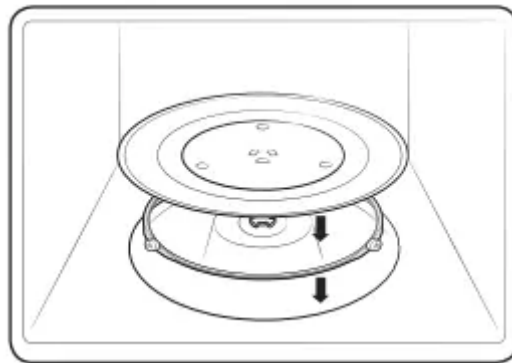

Maintenance

Cleaning

Clean the oven regularly to prevent impurities from building up on or inside the oven. Also pay special attention to the door, door sealing, and turntable and roller ring (applicable models only). If the door won't open or close smoothly, first check if the door seals have built up impurities. Use a soft cloth and soapy water to clean both the inner and outer sides of the oven. Rinse and dry well.

To remove stubborn impurities with bad smells from inside the oven

1. With the oven empty, put a cup of diluted lemon juice on the center of the turntable.
2. Heat the oven for 10 minutes at maximum power
3. When the cycle is complete, wait until the oven cools down. Then, open the door and clean the cooking chamber.

To clean inside swing-heater models

To clean the upper area of the cooking chamber, lower the top heating element by 45° (A) as shown. This will help you clean the upper area. When done, reposition the top heating element.

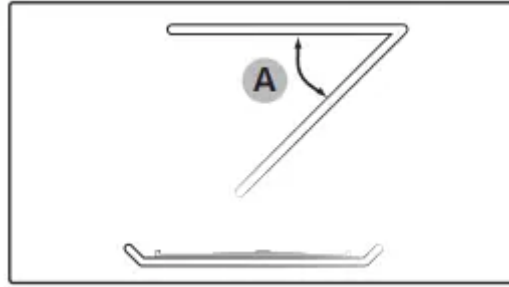

CAUTION

- Keep the door and door sealing clean and ensure the door opens and closes smoothly. Otherwise, the oven's lifecycle may be shortened.
- Take caution not to spill water into the oven vents.
- Do not use any abrasive or chemical substances for cleaning.
- After each use of the oven, use a mild detergent to clean the cooking chamber after waiting for the oven to cool down.

Replacement (repair)

WARNING : This oven has no user-removable parts inside. Do not try to replace parts or repair the oven yourself.

- If you encounter a problem with hinges, sealing, and/or the door, contact a qualified technician or a local Samsung service center for technical assistance.
- If you want to replace the light bulb, contact a local Samsung service center. Do not replace it yourself.
- If you encounter a problem with the outer housing of the oven, first unplug the power cord from the power source, and then contact a local Samsung service center.

Care during an extended period of disuse

- If you don't use the oven for an extended period of time, unplug the power cord and move the oven to a dry, dust-free location. Dust and moisture that builds up inside the oven may affect the performance of the oven.

Before you start

Before you use the microwave for the first time, there is some basic information you should know. This information starts below.

NOTE : Before or during any cooking mode, you can set/change the clock or the kitchen timer.

Current time

It is important to set the correct clock time to ensure correct automatic operations.

1. Press Clock.
2. Use the number buttons to enter the current time. For example, press 5, 0, and 0 in sequence for 5:00 o'clock.
3. Press START to confirm your settings. The colon (:) indicator blinks several times.

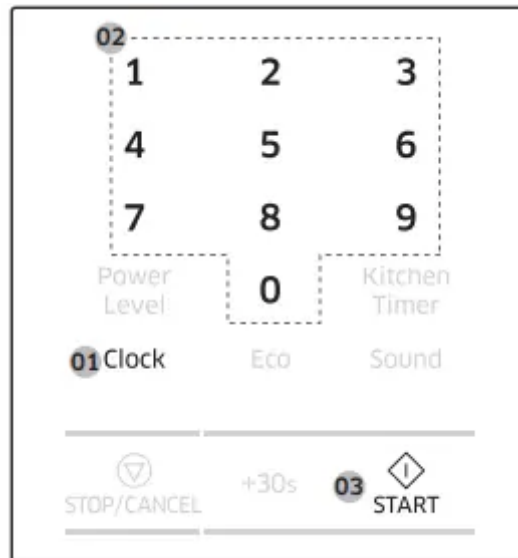

Power saving

To reduce power consumption when not using the oven, use the power saving function of the oven

Auto power saving

- After 25 minutes of user inactivity, the oven automatically enters power saving mode. Any previous function will be cancelled, and the current time will be displayed.
- To activate power saving, press Eco to turn off the display.
- To deactivate power saving, open the door or press Eco again. The display turns back on showing the current time.
- If you open the door and leave it open, the oven light will turn off after 5 minutes.

Child lock

To prevent accidents, Child Lock disables all controls except for the Eco button. Hold down STOP/CANCEL for 3 seconds to activate. Hold down STOP/CANCEL again for 3 seconds to deactivate.



Sound On/Off

You can mute or unmute the sounds (beeps or melody) made by the oven.

- To mute the sounds, press Sound until "OFF" appears in the display. Then, press START.
- To unmute the sounds, press Sound again until "ON" appears in the display. Then, press START.



Kitchen timer

1. Press Kitchen Timer.
2. Press the number buttons to set the length of time. For example, press 3 - 0 - 0 to set the timer to 3 minutes.
3. Press START. The Kitchen Timer counts down the time.

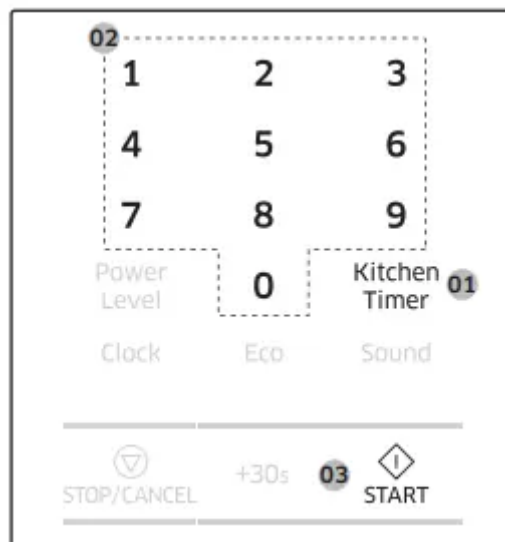

About microwave energy



Microwaves are high-frequency electromagnetic waves. The magnetron built into the oven generates microwaves which cook or reheat food without deforming or discolouring it.

1. The microwaves generated by the magnetron are distributed uniformly by the microwave's distribution system. This is why the food cooks evenly.
2. The microwaves are absorbed by the food to a depth of approx. 1 inch (2.5 cm). Then, the microwaves dissipate inside the food as cooking continues.
3. The cooking time is affected by the following conditions of the food:
 - Quantity and density
 - Moisture content
 - Initial temperature (especially, when frozen)

NOTE : The cooked food retains heat in its core after cooking is complete. This is why you must observe the standing times specified in this manual, which ensures food cooks evenly down to the core.

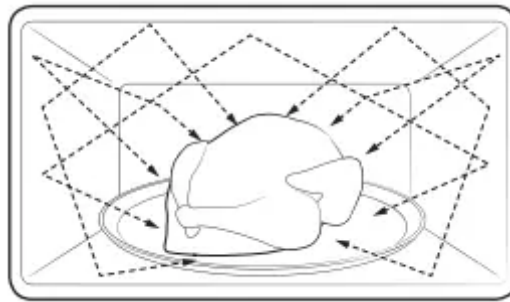

Cookware for microwaving

Cookware used for Microwave Mode must allow microwaves to pass through and penetrate food. Metals such as stainless steel, aluminum, and copper reflect microwaves. Therefore, do not use cookware made of metallic materials. Cookware marked microwave - safe is always safe for use. For additional information on appropriate cookware, refer to the following guide. Requirements:

- Flat bottom and straight sides
- Tight-fitting lid
- Well-balanced pan with handles that weigh less than the main pan

Material		Microwave-safe	Description
Aluminium foil		△	Use for a small serving size to protect against overcooking. Arcing can occur if the foil is near the oven wall or if you use an excessive amount of foil.
Crusty plate		○	Do not use for preheating for more than 8 minutes.
Bone china or earthenware		○	Porcelain, pottery, glazed earthenware, and bone china are usually microwave-safe, unless decorated with a metal trim.
Disposable polyester cardboard dishes		○	Some frozen foods are packaged in these dishes.
Fast-food packaging	Polystyrene cups or containers	○	Overheating may cause these to melt.
	Paper bags or newspaper	×	These may catch fire.
	Recycled paper or metal trims	×	These may cause arcing

○ : Microwave Safe

△ : Use Caution

× : Microwave Unsafe

Material		Microwave-safe	Description
Glassware	Oven-to-table ware	○	Microwave-safe unless decorated with metal trim.
	Fine glassware	○	Rapid heating may cause delicate glassware to break or crack.
	Glass jars	○	Appropriate for warming only. Remove the lid before cooking.
Metal	Dishes	×	These may cause arcing or fire.
	Freezer bag with twist-ties	×	
Paper	Plates, cups, napkins, and kitchen paper	○	Use to cook for a short time. These absorb excess moisture.
	Recycled paper	×	Causes arcing.
Plastic	Containers	○	Use thermoplastic containers only. Some plastics may warp or discolour at high temperatures.
	Cling film	○	Use to maintain moisture after cooking.
	Freezer bags	△	Use boilable or ovenproof bags only.
Wax or grease-proof paper		○	Use to maintain moisture and prevent spattering.

○ : Microwave Safe

△ : Use Caution

× : Microwave Unsafe

Operations

Feature panel

The front panel comes in a wide range of materials and colors. For improved quality, the actual appearance of the oven is subject to change without notice.

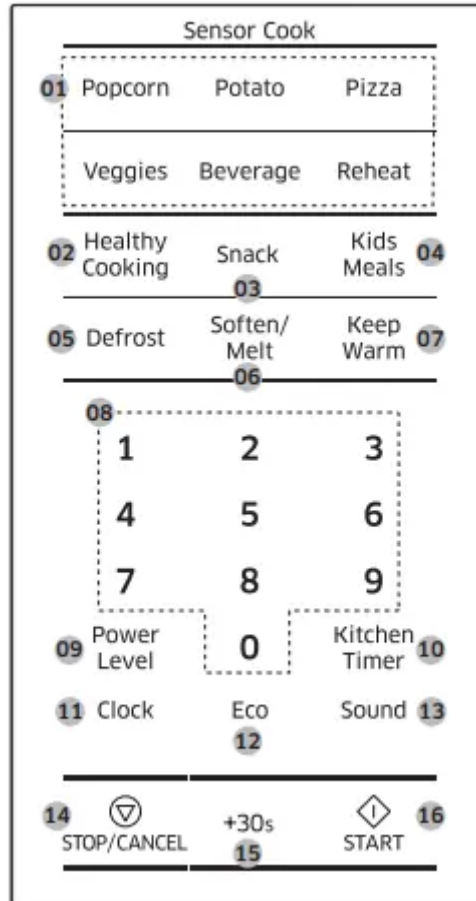

- 01 Sensor Cook
- 02 Healthy Cooking
- 03 Snack
- 04 Kids Meals
- 05 Defrost
- 06 Soften/Melt
- 07 Keep Warm
- 08 Number
- 09 Power Level
- 10 Kitchen Timer
- 11 Clock 12 Eco

13 Sound

14 STOP/CANCEL

15 +30s

16 START

Simple steps to start

To cook food

1. Put the food in a microwave-safe container, and then put the container in the center of the turntable.
2. Use the number buttons to set the cooking time.
3. Press START.

NOTE : When cooking is complete, the oven beeps 4 times. Use oven gloves to take out the food

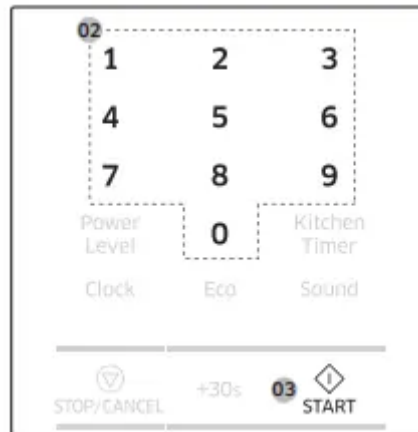

To defrost frozen food

1. Put the frozen food in a microwave-safe container, and then put the container in the center of the turntable.
2. Press Defrost.
3. Use the number buttons to set the serving size.
4. Press START.

NOTE : For more information, see the Defrost section on page 41.



Manual mode

Microwave This is the basic function of this microwave oven. The power level is set to High by default

1. Put food in a microwave-safe container, and then place the container on the turntable.



2. Use the number buttons to set the cooking time (max: 99 min 99 sec). For example, to set the time to 10 minutes, press 1 and 0 for the minutes, and 0 and 0 for the seconds (10:00).
3. To change the default power level, press Power Level, and then select a different level. See the Power level section on page 30 for details.
4. Press START.
5. When cooking is complete, the oven beeps 4 times. Use oven gloves to take out the food.

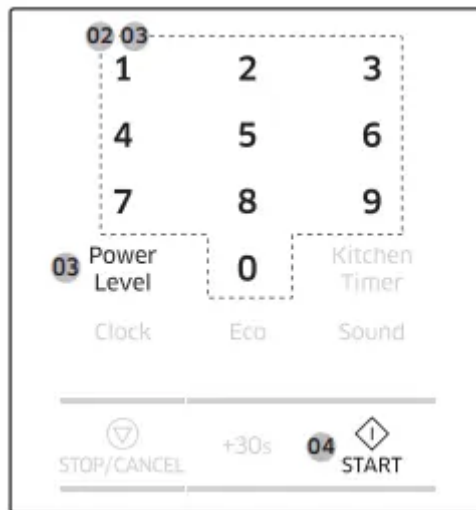

Common settings

Cooking time

Follow these steps to set or change the cooking time. By default, the power level is set to High.

Use the number buttons to set the cooking time (max: 99 min 99 sec). The time area consists of the minute and second elements. To set a cooking time of 25 minutes, for example, press 2 and 5 for the minutes, then 0 and 0 for the seconds.

NOTE :

- To change the cooking time during operation, press STOP/CANCEL twice, and then repeat the steps above.
- To stop cooking, simply open the door, or press STOP/CANCEL. To resume operation, close the door and press START.
- To cancel cooking, press STOP/CANCEL twice.

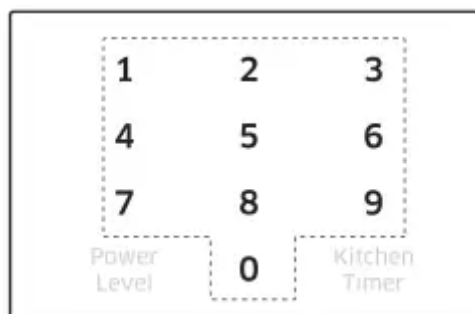

Time increment

You might want to add extra time to the current cooking time while cooking is in progress. Time can be added in 30 second intervals.

1. Before or during cooking, press +30s as many times as needed. For example, to add 2 minutes to the current cooking time, press the button 4 times.

2. Press START. The oven continues to operate for the changed time.

NOTE : This button is not enabled when you use Auto mode.



Power level

Select the cooking time, and then choose the power level before pressing the Start button.

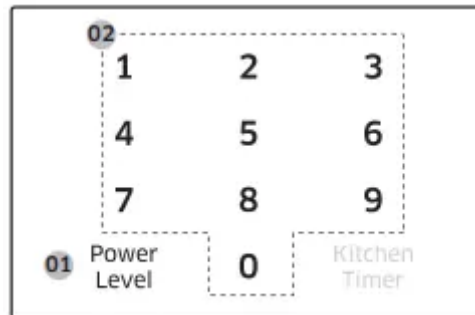

1. Press Power Level.

2. Use the number buttons to select a specific power level. Available levels range from No power (0) to High (10). See the table below



0	PL:0	No power
1	PL:10	Warm
2	PL:20	Defrost
3	PL:30	Low
4	PL:40	Medium low
5	PL:50	Medium
6	PL:60	Simmer
7	PL:70	Medium high
8	PL:80	Reheat
9	PL:90	Sauté
10	PL:Hi	High

Sensor mode

Sensor Cook

For inexperienced cooks, the oven offers a total of 9 Sensor Cook programs in 6 different categories. Take advantage of this feature to save time or shorten your learning curve. The cooking time and temperature will be adjusted according to the selected recipe.

1. Put food in a microwave-safe container, and then put the container in the center of the turntable. 04 02 03
2. Select a category by pressing Popcorn, Potato, Pizza, Veggies, Beverage, or Reheat.
3. Press the selected button again or the number buttons to select a specific program.
4. Press START.
5. When cooking is complete, the oven beeps 4 times. Use oven gloves to take out the food

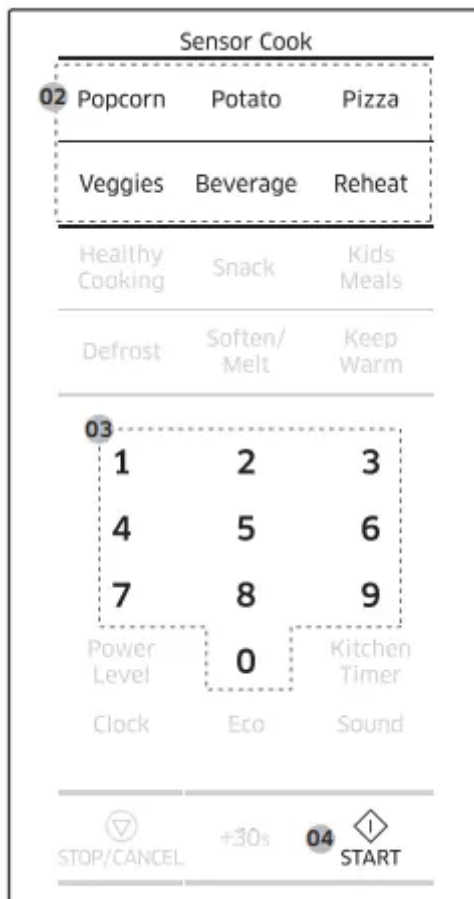

Sensor cook guide

The following table presents auto programs for cooking, roasting, and baking. The table contains food quantities, weight ranges, and appropriate recommendations. Cooking modes and times have been pre-programmed for your convenience.

Code/Food		Serving Size	Instruction
1. Popcorn		3.0 to 3.5 oz. (1 package)	Use only one microwave popcorn bag at a time. Be careful when removing the heated bag from the oven and opening it. Let the oven cool for at least 5 minutes before using it again.
2. Potato		1 to 6 pcs	Pierce each potato several times with a fork. Place on the turntable in a spoke-like fashion. After cooking, let the potatoes stand for 3-5 minutes. Let the oven cool for at least 5 minutes before using it again.
3. Pizza		2 to 4 slices	Place 2-4 pizza slices on a microwave-safe plate with the wide ends of the slices towards the outside edge of the plate. Do not let the slices overlap. Do not cover. Let the oven cool for at least 5 minutes before using it again.
4. Veggies	1. Fresh Vegetables	1 to 4 servings	Place the food in a microwave-safe ceramic, glass, or plastic dish and add 2-4 tbs. water. Cover with vented plastic wrap, and then cook. Stir before letting stand. Let the oven cool for at least 5 minutes before using it again.
	2. Frozen Vegetables	1 to 4 servings	
5. Beverage		8 to 10 oz.	Use a measuring cup or mug and do not cover. Place the beverage in the oven. After heating, stir well. Let the oven cool for at least 5 minutes before using it again.

Code/Food		Serving Size	Instruction
6. Reheat	1. Dinner Plate	1 serving	Use only precooked, refrigerated foods. Cover the plate with vented plastic wrap or waxed paper tucked under the plate. If the food is not as hot as you would like after using the "Sensor" function, continue heating using additional time and power. Let the oven cool for at least 5 minutes before using it again. Contents: 3-4 oz. meat, poultry, or fish (up to 6 oz. with bone) ½ cup starch (potatoes, pasta, rice, etc.) ½ cup vegetables (about 3-4 oz.)
	2. Casserole	1 to 4 servings	Cover the plate with vented plastic wrap. If the food is not as hot as you would like after using the "Sensor Cook" function, continue heating using additional time and power. Stir the food once before serving. Let the oven cool for at least 5 minutes before using it again. Contents: Casseroles, soup, refrigerated foods.
	3. Pasta/Soup	1 to 4 servings	

Auto mode

Healthy Cooking

For healthier alternatives, the oven offers a total of 10 Healthy Cook programs. Take advantage of this feature to save time or shorten your learning curve. The cooking time and temperature will be adjusted according to the selected recipe.

1. Put food in a microwave-safe container, and then put the container in the center of the turntable. 04 03 02
2. Press Healthy Cooking.
3. Press the Healthy Cooking button again or the number buttons to select a specific program.
4. Press START.
5. When cooking is complete, the oven beeps 4 times. Use oven gloves to take out the food.

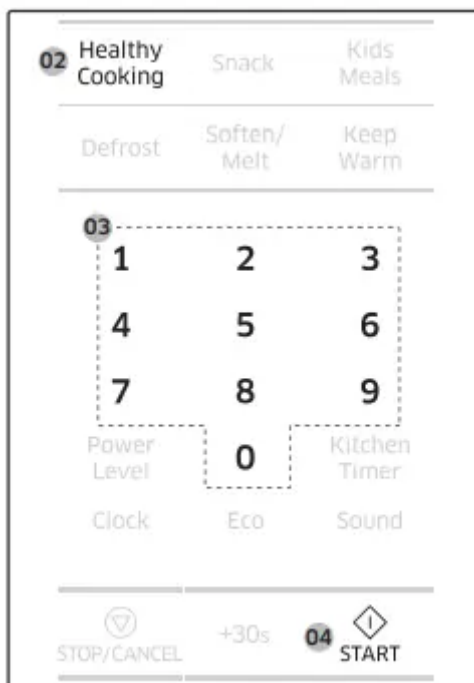

Healthy Cooking guide

The following table lists auto programs for cooking. The table contains food quantities, weight ranges, and appropriate recommendations. Cooking modes and times have been preprogrammed for your convenience.

Code	Food	Serving Size	Instructions
1	Spinach	5.3 oz.	Rinse and clean spinach. Put into a glass bowl with lid. Do not add water. Put bowl in the center of turntable. Cook covered. Stir after cooking. Let stand for 1-2 minutes.
2	Squash	8.8 oz.	Slice the squash in half and remove the seeds. Place the squash cut side down in a microwave safe dish and cover with the plastic wrap. If needed, add a ¼ cup of water.
3	Brown Rice	16 oz.	Use a large glass ovenware dish with lid. Add a double quantity of cold water (500 ml). Cook covered. Stir before standing time and add salt and herbs. Let stand for 5-10 minutes.
4	Oatmeal	1 pack	Follow the package directions for the recommended amount of water needed. Stir well before and afterwards.
5	Quinoa	8.8 oz.	Use a large glass ovenware dish with lid. Add a double quantity of cold water (500 ml). Cook covered. Stir before standing time and add salt and herbs. Let stand for 1-3 minutes.
6	Green Beans	8.8 oz.	Rinse and clean green beans. Put them evenly into a glass bowl with lid. Add 30 ml (2 tbsp) water. Put bowl in the center of turntable. Cook covered. Stir after cooking. Let stand for 1-2 minutes.
7	Chicken Breasts	10.6 oz.	Rinse pieces and put on a ceramic plate. Cover with plastic wrap. Pierce the plastic wrap in 3 or 4 places. Put dish on turntable. Let stand for 2 minutes.

Code	Food	Serving Size	Instructions
8	Fresh Fish Fillet	10.6 oz.	Rinse fish fillets and put on a ceramic plate, add 1 tbsp lemon juice. Cover with plastic wrap. Pierce the plastic wrap in 3 or 4 places. Put dish on turntable. Let stand for 1-2 minutes.
9	Fresh Salmon Fillet	10.6 oz.	Rinse fish fillets and put on a ceramic plate, add 1 tbsp lemon juice. Cover with plastic wrap. Pierce the plastic wrap in 3 or 4 places. Put dish on turntable. Let stand for 1-2 minutes.
10	Fresh Prawns	8.8 oz.	Rinse prawns and put on a ceramic plate, add 1 tbsp lemon juice. Cover with plastic wrap. Pierce the plastic wrap in 3 or 4 places. Put dish on turntable. Let stand for 1-2 minutes.

Snack

The Snack feature has 5 pre-programmed cooking times. You do not need to set either cooking times or the power level

1. Put food in the center of the turntable, and then close the door.
2. Press Snack.
3. Press the Snack button again or the number buttons to select a specific program.
4. Press START.
5. When the cycle is complete, the oven beeps 4 times. Use oven gloves to take out the food.

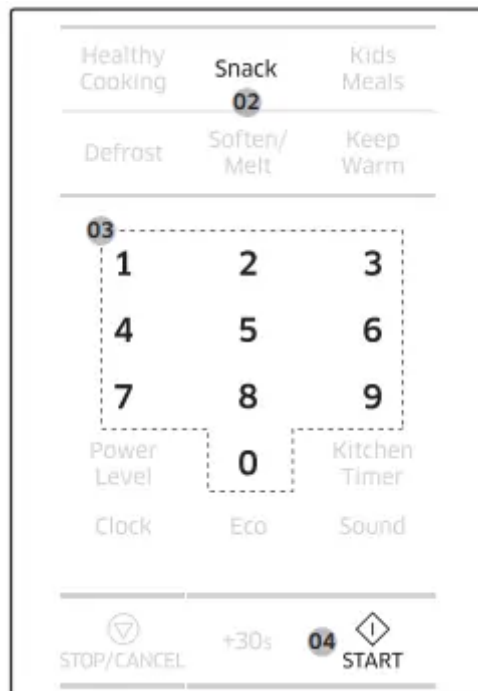

Snack guide

The following table lists auto programs for heating snack foods. The table contains food quantities, weight ranges, and appropriate recommendations.

Code	Food	Serving Size	Instruction
1	Bacon	4 slices	Layer 2 paper towels on microwave safe plate and arrange the bacon on the towels. Do not overlap bacon. Cover with an additional paper towel. Remove the paper towel immediately after cooking.
2	Frozen Cheese Sticks	5-6 pcs	Place the cheese sticks on a plate in a spoke-like fashion. Do not cover. Let stand for 1 to 2 minutes after heating.
3	Frozen Chicken Wings	7-8 oz.	Use precooked, refrigerated chicken wings. Place the chicken wings around the plate in a spoke-like fashion and cover with wax paper. Let stand for 1 to 2 minutes.
4	Nachos	1 serving	Place the nachos on a plate without letting them overlap. Sprinkle cheese evenly over them. Contents: 2 cups tortilla chips 1/3 cup grated cheese
5	Potato Skins	2 (cooked) potatoes	Cut the cooked potato into 4 even wedges. Scoop or cut out the potato flesh, leaving about a ¼ in. flesh on the skin. Place the skins in a spoke-like fashion around the plate. Sprinkle with bacon, onions and cheese. Do not cover. Let stand for 1 to 2 minutes.

Kids Meals

Kids meals feature has 4 pre-programmed cooking times. You do not need to set either cooking times or the power level.

1. Put food in the center of the turntable.

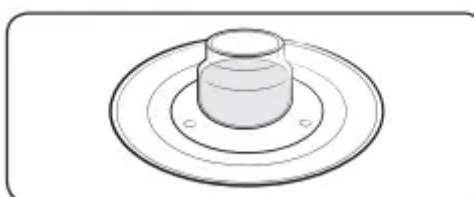

2. Press Kids Meals.
3. Press the Kids Meals or number buttons to select a specific program.
4. Press START.
5. When cooking is complete, the oven beeps 4 times. Use oven gloves to take out the food.

CAUTION : Before inserting food in the oven, remove any metal or plastic cover or lid from the food.

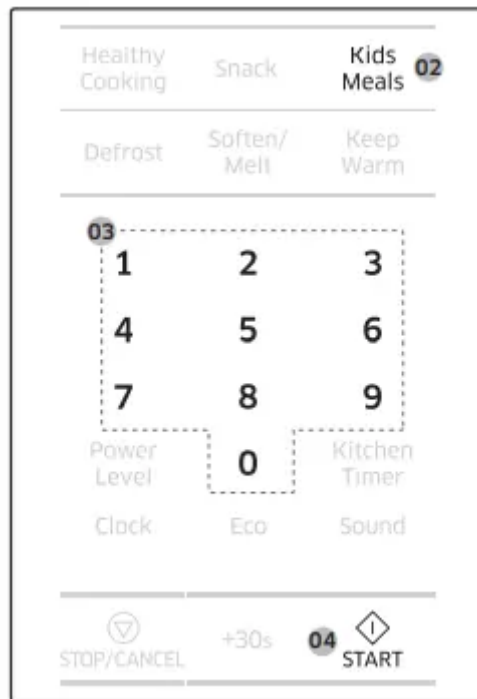

Kids meals guide

Code	Food	Serving Size	Instructions
1	Frozen Chicken Nuggets	1 serving	Place a paper towel on a plate and arrange the nuggets in a spoke-like fashion on the paper towel. Do not cover. Let stand for 1 minute after heating. Refer to the package directions for the serving size and the amount of food.
2	Frozen French Fries	1 serving	Place two paper towels on a microwave safe plate and arrange the French fries on the towels without letting them overlap. Blot the fries with additional paper towels after removing from the oven. Let stand for 1 minute. Refer to the directions on the packaging for the serving size and the amount of food.
3	Frozen Sandwich	1 serving (1 sandwich)	Place the frozen sandwich in a susceptor "crisping sleeve" (which is in the package) and place on a microwave safe plate. Remove from the "crisping sleeve". Let stand for 2 minutes after heating.
4	Hot Dogs	1 serving (2 hot dogs)	Pierce the hot dogs and place them on a plate. When the oven beeps, remove the hot dogs from the oven, put each hot dog in a bun, place the buns and hot dogs in the oven, and then restart the oven. Let stand for 1 minute after heating. For the best texture, the buns should be added to the hot dogs when the oven beeps.

Convenience

Defrost

This is useful to defrost frozen meat, poultry, fish, or bread. The operating time and power level will be adjusted according to the selected program

1. Put food in the center of the turntable, and then close the door.
2. Press Defrost to select a category.
3. Use the number buttons to select a weight.
4. Press START.
5. When the cycle is complete, the oven beeps 4 times. Use oven gloves to take out the food.

NOTE

- The oven beeps in the middle of the cycle to remind you to turn the food over. Turn the food over, and then press Start again to continue. When the cycle is complete, the oven beeps 4 times.
- You can defrost food manually. To do this, set a time, press the 2 button (20 % power), and then press START. For more information, see the Power level section on page 30.

Defrost guide

The following table lists auto programs for defrosting food. The table contains food quantities, weight ranges, and appropriate recommendations.

Code	Food	Serving Size (lb)	Instructions
1	Meat	0.1-3.5	Shield the edges with aluminium foil. Turn the meat over when the oven beeps. This program is suitable for beef, lamb, pork, steaks, chops, minced meat. Let stand for 10-30 minutes.
2	Poultry	0.1-3.5	This program is suitable for whole chicken as well as for chicken pieces. Before defrosting, if there are a large number of ice crystals on the surface of the poultry, rinse the surface with cold water until all the ice crystals are removed. The poultry should then be left to stand for 5 to 10 min. at room temperature. Shield the leg and wing tips with aluminum foil. Place chicken pieces skin-side down, and whole chicken breast-side down on the middle of a flat microwave-safe plate. Turn the poultry over when the oven beeps
3	Fish	0.1-3.5	Shield the tail of a whole fish with aluminium foil. Turn the fish over, when the oven beeps. This program is suitable for whole fish as well as for fish fillets. Let stand for 10-30 minutes.
4	Bread	0.1-3.5	Put bread on a piece of kitchen paper and turn over as soon as the oven beeps. Place cake on a ceramic plate and, if possible, turn over, as soon as the oven beeps. (The oven keeps operating and stops when you open the door.) This program is also suitable for all kinds of bread, sliced or whole, as well as for bread rolls and baguettes. Arrange bread rolls in a circle. In addition, this program is suitable for all kinds of yeast cakes, biscuits, cheese cakes, and puff pastry. It is not suitable for short/crust pastry, fruit and cream or for cakes with chocolate topping. Let stand for 5-30 minutes.

Soften/Melt

This is useful to soften or melt soft food or confections such as butter, chocolate, and sugar.

1. Put food in the center of the turntable.
2. Press Soften/Melt.
3. Press the Soften/Melt button again or the number buttons to select a specific program.
4. Press START.
5. When the cycle is complete, the oven beeps 4 times. Use oven gloves to take out the food



Soften/Melt guide

The following table lists auto programs for softening or melting specific kinds of food. The table contains food quantities, weight ranges, and appropriate recommendations.

Code	Food	Serving Size (g)	Instructions
1	Melting Butter	50 (1.75 oz)	Cut butter into 3 or 4 pieces, and then put them in a small glass bowl. Melt uncovered. Stir after cooking. Let stand for 1-2 minutes.
2	Melting Butter	100 (3.5 oz)	
3	Melting Dark Chocolate	50 (1.75 oz)	Grate dark chocolate, and then put in a small glass bowl. Melt uncovered. Stir after melting. Let stand for 1-2 minutes.
4	Melting Dark Chocolate	100 (3.5 oz)	
5	Melting Sugar	25 (1 oz)	Put sugar in a small glass bowl. Add 10 ml (2 tsp) water for 25 g (1 oz). Add 20 ml water for 50 g (1.75 oz). Melt uncovered. Take out carefully using oven gloves! Use spoon or fork and pour caramel decorations on baking paper. Let stand for 10 minutes until dry, and then remove from paper.
6	Melting Sugar	50 (1.75 oz)	
7	Soften Butter	50 (1.75 oz)	Cut butter into 3 or 4 pieces, and then put them in small glass bowl. Soften uncovered. Let stand for 1-2 minutes.
8	Soften Butter	100 (3.5 oz)	

Keep Warm

If you want to keep cooked foods warm until serving, use this function. The operating time and power level will be adjusted according to the selected program.

1. Put food in the center of the turntable, and then close the door.
2. Press Keep Warm. The default time is 99 minutes.

3. Use the number buttons to set the warming time (max: 99 min 99 sec.).
4. Press START.
5. When the cycle is complete, the oven beeps 4 times. Use oven gloves to take out the food.

CAUTION

- Do not use this function to reheat cold food. Use this only for keeping food that has just been cooked warm.
- Do not keep food for more than 1 hour. The food surface may dry up.
- Do not put food covered with lids or plastic wrap in the oven.



Cooking Smart

We provide these cooking guides to help you make the most out of this oven. Experience our cooking know-how to add convenience and richness to your life.

Microwave cooking guide

- Cover the food for the entire time it is cooking. The vaporised moisture from the food cycles through inside and helps cook the food evenly.
- When cooking is complete, let stand for the specified time. This allows the food to cook evenly throughout. • Use only microwave-safe cookware.

Frozen vegetables

- Use a suitable glass Pyrex container with a lid.
- Stir twice during cooking and once after cooking, and then add the seasoning of your preference.

Food	Serving Size (g)	Power	Time (min.)
Spinach	150 (5.3 oz)	60 %	5-6
	Add 15 ml (1 tbsp) cold water. Let stand for 2-3 minutes.		
Broccoli	300 (10.6 oz)	60 %	8-9
	Add 30 ml (2 tbsp) cold water. Let stand for 2-3 minutes.		
Peas	300 (10.6 oz)	60 %	7-8
	Add 15 ml (1 tbsp) cold water. Let stand for 2-3 minutes.		
Green Beans	300 (10.6 oz)	60 %	7½-8½
	Add 30 ml (2 tbsp) cold water. Let stand for 2-3 minutes.		
Mixed Vegetables (Carrots/Peas/Corn)	300 (10.6 oz)	60 %	7-8
	Add 15 ml (1 tbsp) cold water. Let stand for 2-3 minutes.		
Mixed Vegetables (Chinese style)	300 (10.6 oz)	60 %	7½-8½
	Add 15 ml (1 tbsp) cold water. Let stand for 2-3 minutes.		

Fresh vegetables

- Use a suitable glass Pyrex container with a lid.
- Cut ingredients into as small pieces as possible to reduce the cooking time.
- Add 2-3 tbs (30-45 ml) of cold water to every 250 g (9 oz) unless otherwise specified.
- Stir once during cooking and once after cooking, and then add seasoning to your preference.

Food	Serving Size (g)	Power	Time (min.)
Broccoli	250 (9 oz)	90 %	4½-5
	500 (17.6 oz)		7-8
Prepare even sized florets. Arrange the stems to the center. Let stand for 3 minutes.			
Brussels Sprouts	250 (9 oz)	90 %	6-6½
	Add 60-75 ml (4-5 tbsp) water. Let stand for 3 minutes.		
Carrots	250 (9 oz)	90 %	4½-5
	Cut carrots into even sized slices. Let stand for 3 minutes.		
Cauliflower	250 (9 oz)	90 %	5-5½
	500 (17.6 oz)		7½-8½
Prepare even sized florets. Cut big florets into halves. Arrange stems to the center. Let stand for 3 minutes.			
Courgettes (Zucchini)	250 (9 oz)	90 %	4-4½
	Cut courgettes into slices. Add 30 ml (2 tbsp) water or a pat of butter. Cook until just tender. Let stand for 3 minutes.		
Eggplant	250 (9 oz)	90 %	3½-4
	Cut eggplants into small slices and sprinkle with 1 tbsp lemon juice. Let stand for 3 minutes.		
Leeks	250 (9 oz)	90 %	4-4½
	Cut leeks into thick slices. Let stand for 3 minutes.		
Mushrooms	125 (4.5 oz)	90 %	1½-2
	250 (9 oz)		2½-3
	Prepare small whole or sliced mushrooms. Do not add any water. Sprinkle with lemon juice. Spice with salt and pepper. Drain before serving. Let stand for 3 minutes.		

Food	Serving Size (g)	Power	Time (min.)
Onions	250 (9 oz)	90 %	5-5½
	Cut onions into slices or halves. Add only 15 ml (1 tbsp) water. Let stand for 3 minutes.		
Pepper	250 (9 oz)	90 %	4½-5
	Cut pepper into small slices. Let stand for 3 minutes.		
Potatoes	250 (9 oz)	90 %	4-5
	500 (17.6 oz)		7-8
Weigh the peeled potatoes and cut them into similar sized halves or quarters. Let stand for 3 minutes.			
Turnip Cabbage	250 (9 oz)	90 %	5½-6
	Cut turnip cabbage into small cubes. Let stand for 3 minutes.		

Rice and pasta

Rice

- Use a large-sized glass Pyrex container with a lid. Note that rice doubles in volume during cooking.

Pasta

- Use a large-sized glass Pyrex container. Cook uncovered.

- Add boiling water and a little salt, and stir well. Stir several times during and after cooking.
- Cover with a lid while letting stand, and then drain well.

Food	Serving Size	Power	Time (min.)
White Rice (Parboiled)	250 g (9 oz) 375 g (13.25 oz)	90 %	15-16 17½-18½
	Add 500 ml (2 cups) cold water for 250 g. Add 750 ml (3.125 cups) cold water for 375 g. Let stand for 5 minutes.		
Brown Rice (Parboiled)	250 g (9 oz) 375 g (13.25 oz)	90 %	20-21 22-23
	Add 500 ml (2 cups) cold water for 250 g. Add 750 ml (3.125 cups) water for 375 g. Let stand for 5 minutes.		
Mixed Rice (Rice + Wild Rice)	250 g (9 oz)	90 %	16-17
	Add 500 ml (2 cups) cold water. Let stand for 5 minutes.		

Food	Serving Size	Power	Time (min.)
Mixed Corn (Rice + Grain)	250 g (9 oz)	90 %	17-18
	Add 400 ml (1.66 cups) cold water. Let stand for 5 minutes.		
Pasta	250 g (9 oz)	90 %	10-11
	Add 1000 ml (4 cups) hot water. Let stand for 5 minutes.		

Reheating guide

General

This reheating guide is based on the following standards: That the temperature of liquid at room temperature is between 64.4 °F and 68 °F (18 °C and 20 °C) and that the temperature of chilled food is between 41 °F and 44.6 °F (5 °C and 7 °C). Follow the operating time, power level, and standing times specified in this table.

Food	Serving Size	Power	Time (min.)
Drinks (Coffee, Tea and Water)	150 ml (1 cup)	90 %	1-1½
	300 ml (2 cups)		2-2½
	450 ml (3 cups) 600 ml (4 cups)		3-3½ 3½-4
Pour into cups and reheat uncovered: 1 cup in the center, 2 cups opposite of each other, 3 cups in a circle. Keep in microwave oven during standing time and stir well. Let stand for 1-2 minutes.			
Soup (Chilled)	250 g (9 oz) 350 g (12.3 oz) 450 g (15.87 oz) 550 g (1.2 lb)	90 %	2½-3 3-3½ 3½-4 4½-5
	Pour into a deep ceramic plate or deep ceramic bowl. Cover with plastic lid. Stir well after reheating. Stir again before serving. Let stand for 2-3 minutes.		
	Stew (Chilled)		350 g (12.3 oz)
Put stew in a deep ceramic plate. Cover with plastic lid. Stir occasionally during reheating and again before standing and serving. Let stand for 2-3 minutes.			

Food	Serving Size	Power	Time (min.)
Pasta with Sauce (Chilled)	350 g (12.3 oz)	60 %	3½-4½
	Put pasta (e.g. spaghetti or egg noodles) on a flat ceramic plate. Cover with microwave cling film. Stir before serving. Let stand for 3 minutes.		
Filled Pasta with Sauce (Chilled)	350 g (12.3 oz)	60 %	4-5
	Put filled pasta (e.g. ravioli, tortellini) in a deep ceramic plate. Cover with plastic lid. Stir occasionally during reheating and again before standing and serving. Let stand for 3 minutes.		
Plated Meal (Chilled)	350 g (12.3 oz)	60 %	4½-5
	450 g (15.87 oz)		5½-6½
Put a meal of 2-3 chilled components on a ceramic dish. Cover with plastic cling-film. Let stand for 3 minutes.			
Cheese Fondue Ready-to-Serve (Chilled)	400 g (14 oz)	60 %	6-7
	Put the ready-to-serve cheese fondue in a suitable sized glass pyrex bowl with lid. Stir occasionally during and after reheating. Stir well before serving. Let stand for 1-2 minutes.		

Special care for baby food

To prevent accidents such as burns, special care must be taken with baby food before serving. Make sure to strictly follow this reheating guide for baby food. Baby food

- Use a deep ceramic plate and cover it with a plastic lid.
- Recommended serving temperature is 86-104 °F (30-40 °C). Baby milk
- Use a sterilised glass bottle and reheat it uncovered.
- Remove the nipple before reheating. Otherwise, the milk in the bottle can boil over.

Food	Serving Size	Power	Time (sec.)
Baby Food (Vegetables + Meat)	6.7 oz (190 g)	60 %	30
	Empty into ceramic deep plate. Cook covered. Stir after cooking time. Before serving, stir well and check the temperature carefully. Let stand for 2-3 minutes.		

Food	Serving Size	Power	Time (sec.)
Baby Porridge (Grain + Milk + Fruit)	6.7 oz (190 g)	60 %	20
	Empty into ceramic deep plate. Cook covered. Stir after cooking time. Before serving, stir well and check the temperature carefully. Let stand for 2-3 minutes.		
Baby Milk	3.4 oz (100 ml)	30 %	30-40
	6.7 oz (200 ml)		60-70
Stir or shake well and pour into a sterilised glass bottle. Place in the center of turn-table. Cook uncovered. Shake well and let stand for at least 3 minutes. Before serving, shake well and check the temperature carefully.			

Defrosting guide

This defrosting guide is based on the following standard: That frozen food has an internal temperature between 0 °F and -4 °F (-18 °C and -20 °C). The standing time varies depending on the food type (meat or vegetables) and serving size (thinner or thicker pieces of food).

- Put frozen food in a microwave-safe container uncovered.
- Turn it over halfway through defrosting time and drain well when complete.

Food		Serving Size	Power	Time (min.)
Meat	Minced (Ground) Meat	250 g (9 oz)	20 %	6-7
		500 g (1.1 lb)		8-13
	Pork Steaks	250 g (9 oz)		7-8
Place the meat on turntable. Shield thinner edges with aluminium foil. Turn over after half of defrosting time! Let stand for 15-30 minutes.				
Poultry	Chicken Pieces	500 g (1.1 lb) (2 pcs)	20 %	14-15
	Whole Chicken	1200 g (2.65 lb)		32-34
First, put chicken pieces skin-side down, whole chicken breast-side-down on a flat ceramic plate. Shield the thinner parts like wings and ends with aluminium foil. Turn over after half of defrosting time! Let stand for 15-60 minutes.				

Food		Serving Size	Power	Time (min.)
Fish	Fish Fillets	250 g (7 oz)	20 %	6-7
	Whole Fish	400 g (14 oz)		11-13
Put frozen fish in the middle of a flat ceramic plate. Arrange the thinner parts under the thicker parts. Shield narrow ends of fillets and tail of whole fish with aluminium foil. Turn over after half of defrosting time! Let stand for 10-25 minutes.				
Fruit	Berries	300 g (10.6 oz)	20 %	6-7
	Spread fruit on a flat, round glass dish (with a large diameter). Let stand for 5-10 minutes.			
Bread	Bread Rolls (Each ca. 50 g)	2 pcs	20 %	1-1½
		4 pcs		2½-3
	Toast/Sandwich	250 g (9 oz)		4-4½
	German Bread (Wheat + Rye Flour)	500 g (1.1 lb)		7 - 9
Arrange rolls in a circle or bread horizontally on kitchen paper in the middle of turntable. Turn over after half of defrosting time! Let stand for 5-20 minutes.				

Quick & easy

Melting crystallized honey

Put 7 oz (20 g) crystallized honey into a small deep glass dish. Heat for 20-30 seconds using 30 %, until honey is melted.

Melting gelatine

Put dry gelatine sheets (10 g/3.5 oz) into cold water for 5 minutes. Put drained gelatine into a small glass pyrex bowl. Heat for 1 minute using 30 %. Stir after melting.

Cooking glaze/icing (for cake and gateaux)

Mix instant glaze (approximately 14 g/5 oz) with 40 g (1.5 oz) sugar and 250 ml (8.5 oz) cold water. Cook uncovered in a glass pyrex bowl for 3½ to 4½ minutes using 90 %, until glaze/ icing is transparent. Stir twice during cooking.

Cooking jam

Put 600 g (1.3 lb) fruit (for example mixed berries) in a suitably sized glass pyrex bowl with lid. Add 300 g (10.5 oz) preserving sugar and stir well. Cook covered for 10-12 minutes using 90 %. Stir several times during cooking. Empty directly into small jam glasses with twist-off lids. Let stand for 5 minutes.

Cooking pudding/ custard

Mix pudding powder with sugar and milk (500 ml/2 cups) by following the manufacturers instructions and stir well. Use a suitably sized glass pyrex bowl with lid. Cook covered for 6½ to 7½ minutes using 90 %. Stir well several times during cooking.

Browning almond slices

Spread 30 g (1 oz) sliced almonds evenly on a medium sized ceramic plate. Stir several times during browning for 3½ to 4½ minutes using 60 %. Let stand for 2-3 minutes in the oven. Use oven gloves while taking out!

Troubleshooting

Checkpoints

Problem	Cause	Action
General		
The buttons cannot be pressed properly.	Foreign matter may be caught between the buttons.	Remove the foreign matter and try again.
	For touch models: Moisture is on the exterior.	Wipe the moisture from the exterior
	Child lock is activated.	Deactivate Child lock.
The time is not displayed.	Power is not supplied.	Make sure power is supplied. Confirm the microwave is plugged in. Check your fuses or circuit breakers.
	The Eco (power-saving) function is set.	Turn off the Eco function.
The oven does not work.	Power is not supplied.	Make sure power is supplied. Confirm the microwave is plugged in. Check your fuses or circuit breakers
	The door is open	Close the door and try again
	The door open safety mechanisms are covered in foreign matter.	Remove the foreign matter and try again.
The oven stops while in operation.	The user has opened the door to turn food over.	After turning over the food, press the Start button again to start operation.
The power turns off during operation.	The oven has been cooking for an extended period of time.	After cooking for an extended period of time, let the oven cool.
	The cooling fan is not working.	Listen for the sound of the cooling fan.
	Trying to operate the oven without food inside.	Put food in the oven.
		There are intake/exhaust outlets on the front and rear of the oven for ventilation. Check the

	There is not enough ventilation space around the oven.	installation guide and make sure that the microwave is far enough away from walls and cabinets for proper ventilation
	Several appliances or devices are plugged into the same outlet	Unplug all other appliances or devices from the outlet.
There is no power to the oven.	Power is not supplied.	Make sure power is supplied. Confirm the microwave is plugged in. Check your fuses or circuit breakers
There is a popping sound during operation, and the oven doesn't work	Cooking sealed food or using a container with a lid may causes popping sounds.	Do not use sealed containers as they may burst during cooking due to expansion of the contents
The oven exterior gets too hot during operation.	There is not enough ventilation space around the oven.	There are intake/exhaust outlets on the front and rear of the oven for ventilation. Check the installation guide and make sure that the microwave is far enough away from walls and cabinets for proper ventilation.
	Objects are on top of the oven	Remove all objects on the top of the oven.
The door cannot be opened properly	Food residue is stuck between the door and oven interior.	Clean the oven and then open the door.
The oven does not heat.	The oven may not work, too much food is being cooked, or improper cookware is being used.	To test the oven, put one cup of water in a microwave-safe container, put the container in the oven, and then run the microwave for 1-2 minutes to check whether the water is heated. If the water is heated, reduce the amount of food and start the function again. Use a cooking container with a flat bottom
Heating is weak or slow	The oven may not work, too much food is being cooked, or improper cookware is being used.	To test the oven, put one cup of water in a microwave-safe container, put the container in the oven, and then run the microwave for 1-2 minutes to check whether the water is heated. If the water is heated, reduce the amount of

		food and start the function again. Use a cooking container with a flat bottom.
The warm function does not work.	The oven may not work, too much food is being cooked, or improper cookware is being used.	To test the oven, put one cup of water in a microwave-safe container, put the container in the oven, and then run the microwave for 1-2 minutes to check whether the water is heated. If the water is heated, reduce the amount of food and start the function again. Use a cooking container with a flat bottom.
The thaw function does not work.	The oven may not work, too much food is being cooked, or improper cookware is being used.	To test the oven, put one cup of water in a microwave-safe container, put the container in the oven, and then run the microwave for 1-2 minutes to check whether the water is heated. If the water is heated, reduce the amount of food and start the function again. Use a cooking container with a flat bottom.
The interior light is dim or does not turn on.	The door has been left open for a long time.	The interior light may automatically turn off when the Eco function operates. Close and reopen the door or press the "Cancel" button.
	The interior light is covered by foreign matter.	Clean the inside of the oven and check again.
A beeping sound occurs during cooking	If the Auto Cook function is being used, this beeping sound means it's time to turn over the food during thawing.	After turning over the food, press the Start button again to restart operation.
The oven is not level.	The oven is installed on an uneven surface.	Make sure the oven is installed on flat, stable surface.
There are sparks during cooking.	Metal containers are used during the oven/thawing functions.	Do not use metal containers
When power is connected, the oven immediately starts to work.	The door is not properly closed	Close the door and check again.

There is electricity coming from the oven.	The power or power socket is not properly grounded.	Make sure the power and power socket are properly grounded.
There is water dripping.	Water or steam may be generated by the cooking or defrosting process, depending on the food. This is not an oven malfunction.	Let the oven cool and then wipe with a dry dish towel.
Steam leaks from the door.	Water or steam may be generated by the cooking or defrosting process, depending on the food. This is not an oven malfunction.	Let the oven cool and then wipe with a dry dish towel.
There is water left in the oven.	Water or steam may be generated by the cooking or defrosting process, depending on the food. This is not an oven malfunction	Let the oven cool and then wipe with a dry dish towel.
The brightness inside the oven varies.	Changes in brightness reflect changes in power output. Power output changes depending on the functions in use.	Power output changes during cooking are not malfunctions.
Cooking is finished, but the cooling fan is still running.	To ventilate the oven, the cooling fan continues to run for about 5 minutes after cooking is complete.	This is not an oven malfunction.
Pressing the +30sec button operates the oven.	This happens when the oven was not operating.	The microwave oven is designed to start operating when you press the +30 sec button if it was not operating.
Turntable		
While turning, the turntable comes		Install the roller ring and then try again.

out of place or stops turning.	There is no roller ring, or the roller ring is not properly in place.	
The turn table drags while turning.	The roller ring is not properly in place, there is too much food, or the container is too large and touches the inside of the microwave.	Adjust the amount of food and do not use containers that are too large.
The turn table rattles while turning and is noisy	Food residue is stuck to the bottom of the oven.	Remove any food residue stuck to the bottom of the oven.

Information code

Code	Description	Action
C-d0	Control buttons are pressed over 10 seconds.	Clean the keys and check if there is water on the surface around the keys. If this occurs again, turn off the microwave oven for more than 30 seconds, and then try setting again. If this code appears again, call your local Samsung service center.
C-10	The GAS Sensor is open.	Unplug the power cord of the oven, and then contact a local Samsung service center
	The GAS Sensor is shorted.	

Technical specification

Model		MS14K6000**
Power Source		120 V ~ 60 Hz
Power Consumption		1600 W
Output Power		100 W / 1000 W (IEC - 705)
Operating Frequency		2450 MHz
Magnetron		OM75P (31)
Cooling Method		Cooling fan motor
Dimensions (W x H x D)	Main unit	21 ²⁷ / ₃₂ X 12 ⁴¹ / ₁₂₈ X 18 ⁵ / ₈ (in)
	Cooking chamber	14 ⁴⁹ / ₆₄ X 10 ⁵ / ₁₆ X 16 ¹ / ₁₆ (in)
Volume		1.4 cu.ft
Weight	Net	37.5 lbs.

Warning

This content is compiled from multiple sources and is provided for reference purposes only. It may not be complete or fully applicable to all situations. If you are unable to resolve your issue, please contact the product manufacturer or an authorized service provider for official support.