

Refrigerator features

NON ICE AND WATER FEATURES

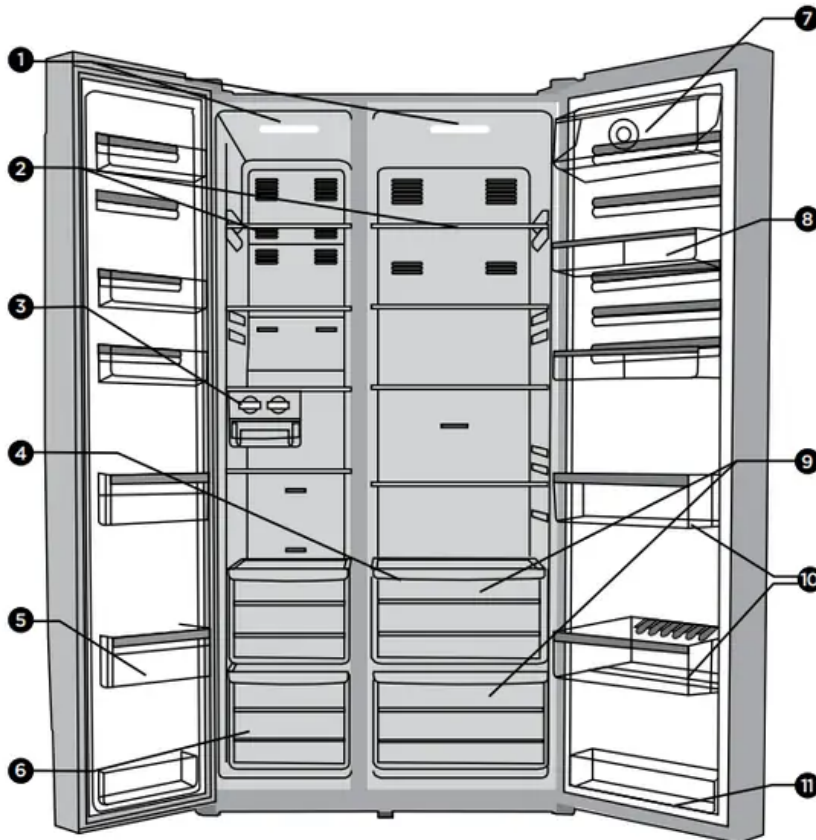

- ❶ LED lighting
- ❷ SpillSafe™ glass shelves
- The glass shelves improve visibility and isolate leaks - preventing spills from dripping down to the shelves below.
- ❸ Twist and Serve Ice maker.
- ❹ Humidity control - Change the humidity by sliding the humidity control. Less humid conditions are recommended for fruit, while more humid conditions are recommended for vegetables.
- ❺ Freezer door bin.
- ❻ Freezer baskets.
- ❼ FamilySafe lockable compartment - This compartment can be used to store dairy and is also lockable for storing items like cosmetics and medicines. To operate the lock, squeeze and turn the knob located on the front of the bin as indicated.
- ❽ FlexFresh crisper - Use the crisper to store vegetables, fruit or small goods. Change the humidity by sliding the humidity control.
- ❾ Bottle storage bin with fingers - Use the bottle bin for tall bottle storage. The bottle bin can be removed by lifting it up over the support lugs. To replace, push down over the support lugs to lock in place.
- ❿ Can bin - Use the can bin for the handy storage of cans or small jars.

Features may vary depending on model. Not all models will have features listed.

Control panel

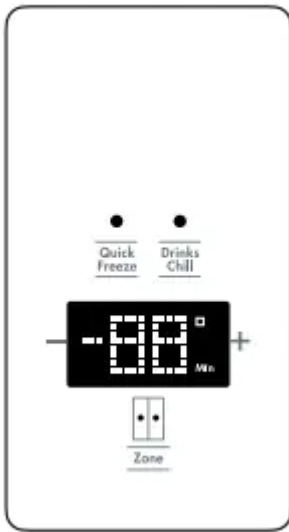

From this panel you can control the temperature of the refrigerator and freezer compartments as well as setting the quick freeze and drinks chill functions. For further information on how to use this feature refer to the section “About the User Interface”.

ICE AND WATER FEATURES

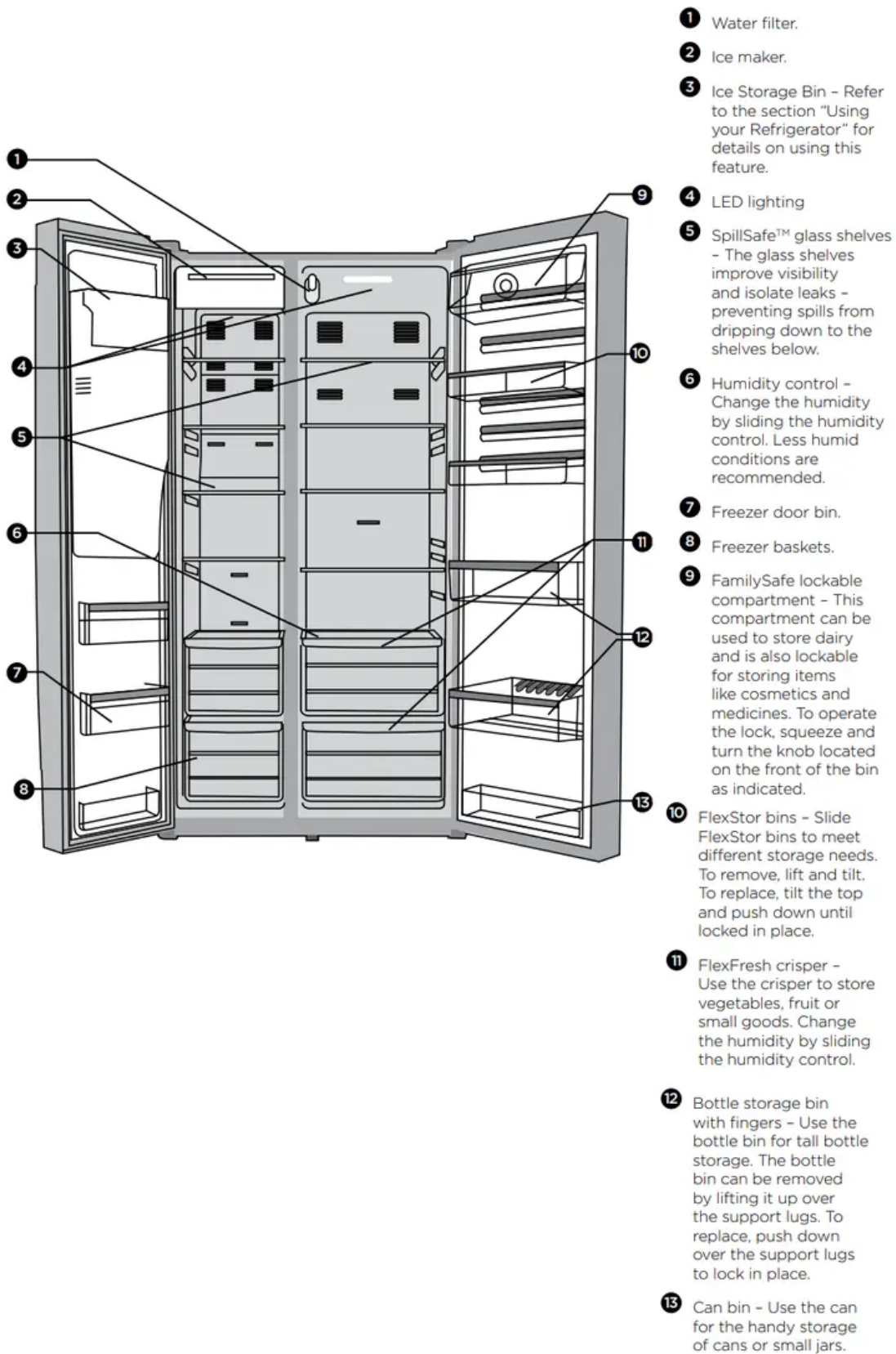

- 1 Water filter.
- 2 Ice maker.
- 3 Ice Storage Bin - Refer to the section "Using your Refrigerator" for details on using this feature.
- 4 LED lighting
- 5 SpillSafe™ glass shelves - The glass shelves improve visibility and isolate leaks - preventing spills from dripping down to the shelves below.
- 6 Humidity control - Change the humidity by sliding the humidity control. Less humid conditions are recommended.
- 7 Freezer door bin.
- 8 Freezer baskets.
- 9 FamilySafe lockable compartment - This compartment can be used to store dairy and is also lockable for storing items like cosmetics and medicines. To operate the lock, squeeze and turn the knob located on the front of the bin as indicated.
- 10 FlexStor bins - Slide FlexStor bins to meet different storage needs. To remove, lift and tilt. To replace, tilt the top and push down until locked in place.
- 11 FlexFresh crisper - Use the crisper to store vegetables, fruit or small goods. Change the humidity by sliding the humidity control.
- 12 Bottle storage bin with fingers - Use the bottle bin for tall bottle storage. The bottle bin can be removed by lifting it up over the support lugs. To replace, push down over the support lugs to lock in place.
- 13 Can bin - Use the can for the handy storage of cans or small jars.

Features may vary depending on model. Not all models will have features listed.



Control panel

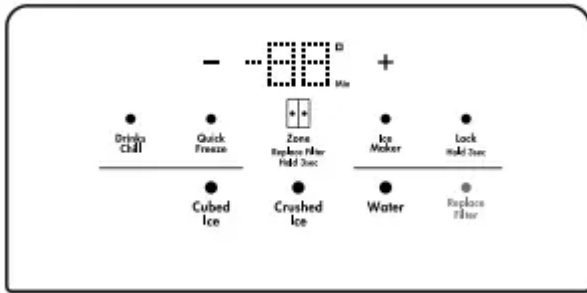

From this panel you can control the temperature of the refrigerator and freezer compartments as well as setting the quick freeze and all the icemaker functions. For further information on how to use this feature refer to the section “About the User Interface”.

USING YOUR REFRIGERATOR

Refrigerators work by transferring heat from the food inside to the outside air. This operation makes the back and sides of the refrigerator feel warm or even hot particularly at start-up and on warm days – this is normal.

Avoid placing food against the air vents in the refrigerator as it affects efficient circulation. If the door is opened frequently, a light frosting will occasionally occur on the freezer’s interior. This is normal and will clear after a few days. If the freezer door is accidentally kept open, a heavy frost will coat the inside walls and should be removed.

Your new refrigerator uses a high-speed compressor, along with other energy-efficient components, which may make unusual sounds and be more noticeable at night and quieter times. These sounds simply indicate your refrigerator is working how it should. They include:

- Compressor running noises;
- Air movement noise from the small fan motor;
- A gurgling sound, similar to water boiling;
- A popping noise, heard during automatic defrosting; and
- A clicking noise, prior to compressor start-up.

Further details can be found in the Troubleshooting Guide.

Temperature Sensors

Avoid loading food against your freezer temperature sensor.

Doing so may adversely affect freezer temperatures. If warm food is inadvertently loaded against the sensor, it may also set off the freezer temperature alarm for up to 50 minutes after the food is loaded against the sensor.

Twist ice and Serve

To use, remove the tray, fill with water and place back in the freezer.

Once ice has formed (approximately 3 hours) simply twist the knob at the front clockwise until the ice drops into the bin below.

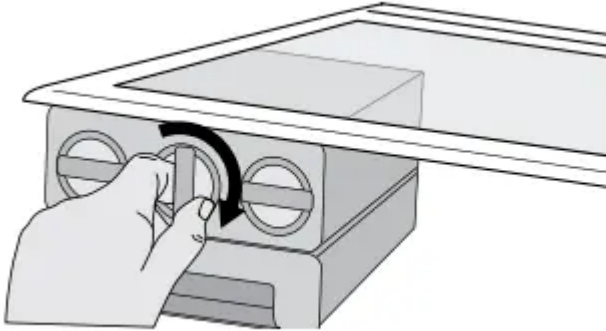

Ice and water dispenser features

The ice and water dispenser conveniently dispenses cool, filtered water and ice cubes or crushed ice.

To operate the ice dispenser, select an ice option using the electronic display and press a glass against the dispensing paddle.

To stop dispensing ice, pull the glass away from the dispensing paddle. Remove the glass from the dispenser paddle when it is approximately half full.

Ice already in the chute may cause the glass to overflow or back up into the chute and cause a blockage (refer to troubleshooting guide on how to unblock the ice chute).

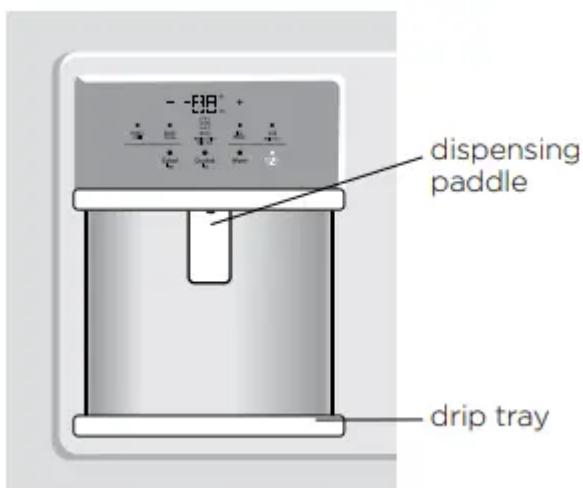

To operate the water dispenser, select the water option on the electronic display, press a glass against the dispensing paddle.

To stop dispensing water, pull the glass away from the water dispensing paddle. As the ice and water cut-off is not instant, leave glass under the dispenser until the ice and water has completely stopped to avoid spills.

A drip tray located at the base of the dispenser (see diagram above) will catch small spills and allow them to evaporate.

Opening the freezer door will de-activate the ice dispenser.

USING YOUR REFRIGERATOR

Bottle filling function

The bottle filling function facilitates the flow of water directly into the mouth of a bottle, minimising splashing and spillage. Water flows from the water dispensing nozzle located on the underside of the ice and water dispenser.

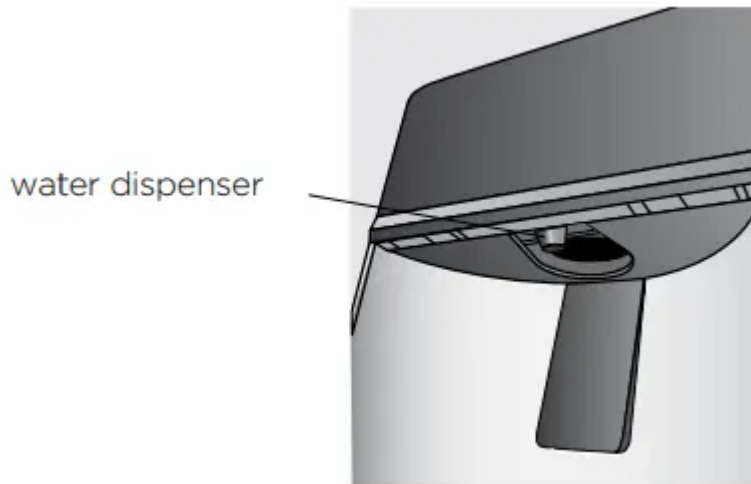

To use this function, place the mouth of the bottle over the water dispensing nozzle.

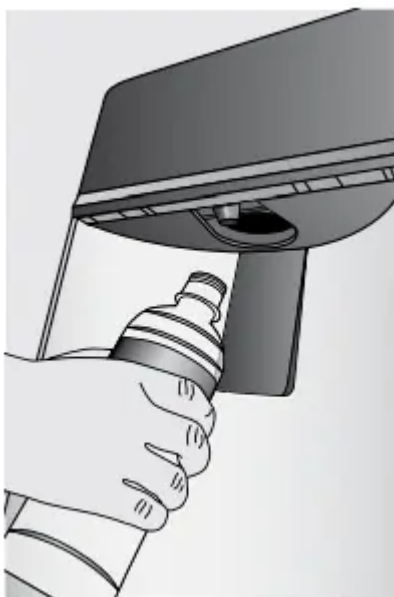

Once the mouth of the bottle is completely over the water dispensing nozzle (see diagram below) gently push bottle up to dispense water and fill bottle. Once the bottle is full, remove the bottle and the flow of water will stop automatically



Controlling the temperature

The default temperature for the refrigerator is 3°C and -18°C for the freezer. If you want to change the temperature, follow the instructions on the following pages.

Make only small adjustments and wait 24 hours to see if it's correct. Checking the softness of ice cream is a good indication of whether your freezer is at the correct temperature, while feeling the coldness of water kept in your refrigerator is a good way of checking the temperature of the food compartment.

NOTE: The set temperature for the refrigerator is an average temperature for the whole refrigerator cabinet. Temperatures inside each compartment may vary depending on how much food you store and where you place it. High or low temperature may also affect the actual temperature inside the refrigerator

Door alarm

Your new appliance is fitted with a door alarm. This alarm will sound if the refrigerator or freezer door is left open for longer than 3 minutes. To silence the alarm, check for any obstructions preventing the door from closing and remove or simply close the door.

ABOUT THE USER INTERFACE

Controls – Non ice and water refrigerator models

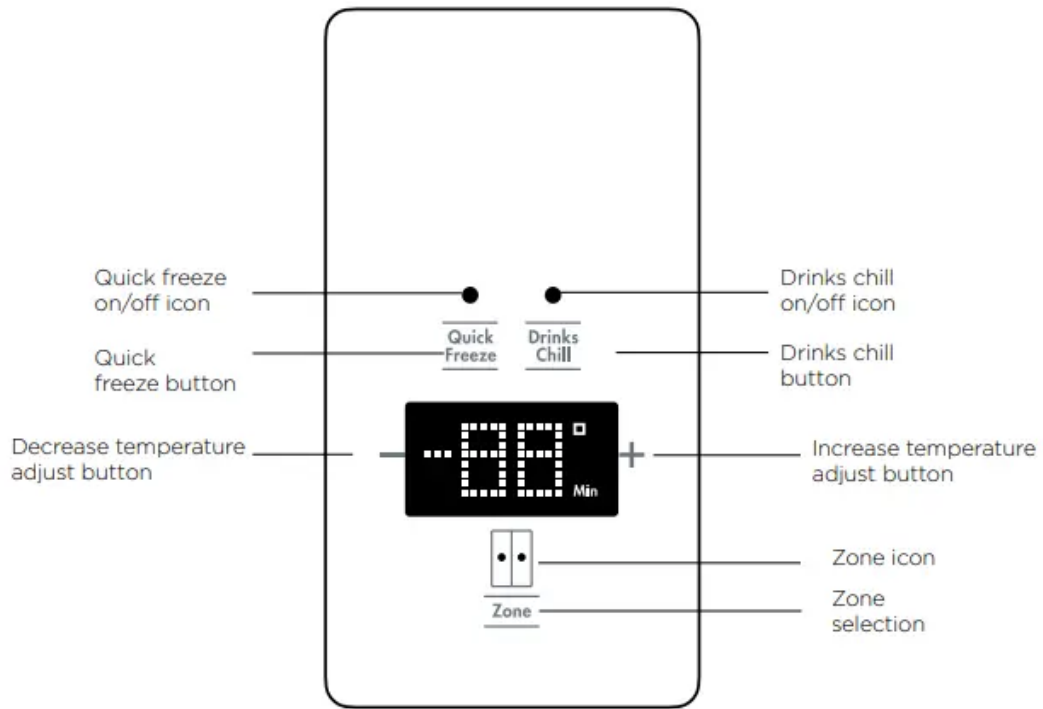

DESCRIPTION	OPERATION / PRIMARY FUNCTION
Quick Freeze on/ off icon	<ul style="list-style-type: none"> • Indicates the status of the Quick Freeze function.
Quick Freeze button	<p>Use the Quick Freeze function when you add a large amount of food to the freezer compartment.</p> <ul style="list-style-type: none"> • Press the 'Quick Freeze' button. The Quick Freeze icon will flash indicating that the quick freeze is active and the compressor will run continuously for 90 minutes. • After 90 minutes the freezer will automatically return to normal mode. • The Quick Freeze function can be cancelled anytime by pressing the button again.
Drinks Chill on/off icon	<ul style="list-style-type: none"> • Indicates the status of the Drinks chill function.
Drinks Chill button	<p>Sets a timer for between 1 and 30 minutes as a reminder for when drinks are placed in the freezer for quick chill.</p> <ul style="list-style-type: none"> • To turn on press the drinks chill button an initial time of 20 mins will appear on the digital display. To adjust time use the '+' and buttons. • An alarm will sound when time is finished. • Press the drinks chill button to turn off during or after countdown. The time taken to chill depends on the size of your bottle. <p>Do not leave the bottle inside the freezer longer than the time needed for chilling.</p>
Digital display	<ul style="list-style-type: none"> • Indicates the temperature setting of the refrigerator compartment. • Indicates the temperature setting of the freezer compartment.
Temperature adjust buttons	<ul style="list-style-type: none"> • Touch any button to awaken control. • Touch the button to decrease or the '+' button to increase the selected compartment temperature. • Once the coldest temperature is reached the display will return to the warmest setting with the next press.
Zone Icon	<ul style="list-style-type: none"> • Indicates the selected zone.

Zone select button	<ul style="list-style-type: none"> • Press to select the desired compartment. • The refrigerator / freezer indication icon will show which zone is selected and the digital display will show the currently set temperature for that compartment.
--------------------	---

IMPORTANT If you want to change the temperature, remember to make only small adjustments and wait 24 hours to see if it's correct.

Controls – ice and water model

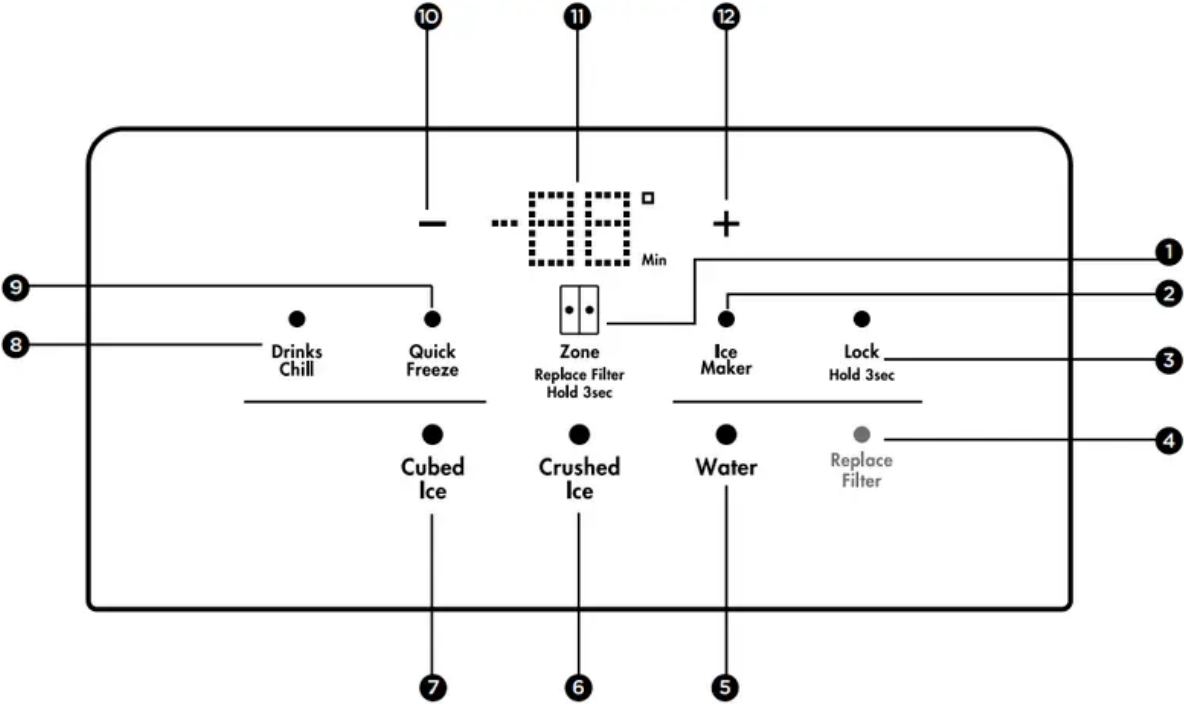









BUTTON / ICON	DESCRIPTION	PRIMARY FUNCTION
1	Compartment Selector button	Selects controllable compartment.
2	Ice & Water on/off button	Selects operational status.
3	Lock Icon	Indicates if the user interface is locked.
4	Filter status indicators	Indicates filter replacement timing.
5	Water on/off button	Selects operational status.
6	Crushed Ice Button	Selects crushed ice.
7	Cube Ice button	Selects cubed ice.
8	Drinks Chill button	Selects drinks chill timer.
9	Quick freeze button	Enables quick freeze model.
10	Decrease button	Decreases temperature of selected compartment.
11	Digital display	Indicates temperature of selected compartment.
12	Increase button	Increases temperature of selected compartment.



IMPORTANT The factory default settings for the refrigerator is “3°” and “-18°C” for the freezer. If you want to change the temperature, remember to make only small adjustments and wait 24 hours to see if it’s correct.

FUNCTIONS OF THE USER INTERFACE

ice and water model

FUNCTION	ICON	OPERATION
Setting the freezer temperature		<ul style="list-style-type: none"> Press button 1 until freezer is displayed on icon 1. Press buttons 10 or 12 to adjust temperature up or down.
Setting the refrigerator temperature		<ul style="list-style-type: none"> Press button 1 until the refrigerator is displayed on icon 1. Press buttons 10 or 12 to adjust temperature up or down.
Quick freeze mode Decreases the freezer temperature to -23°C for 12 hours before returning to pre-set mode.	 Quick Freeze	<ul style="list-style-type: none"> Press button 9 until the freeze icon is illuminated. Quick freeze mode can be deselected using button 9.
Ice Maker Enables/disables ice making features.	 Ice Maker	<ul style="list-style-type: none"> To enable/disable press button 2.
Display Lock Deactivates the user interface controls.	 Lock Hold 3sec	<ul style="list-style-type: none"> To turn on/off press and hold button 3 for 3 seconds, the lock icon is illuminated when activated.
Drinks Chill Sets a timer for between 1 and 30 minutes as a reminder for when drinks are placed in the freezer for quick chill.	 Drinks Chill	<ul style="list-style-type: none"> To turn on press button 8 and initial time of 20 mins will appear on digital display. To adjust time use buttons 10 and 12. Alarm will sound when time is finished. Press button 8 to turn off during or after countdown. The time taken to chill depends on the size of your bottle. Do not leave the bottle inside the freezer longer than the time needed for chilling.
Water on/off Enables/disables water dispensing features.	 Water	<ul style="list-style-type: none"> To enable/disable press button 5.
Cubed Ice Press this button to dispense cubed ice.	 Cubed Ice	<ul style="list-style-type: none"> Press button 6 for cubed ice to dispense. Press the dispenser lever to dispense the ice.
Crushed Ice Press this button to dispense crushed ice.	 Crushed Ice	<ul style="list-style-type: none"> Press button 7 for crushed ice to dispense. Press the dispenser lever to dispense the ice.
Replace Filter Press this button to reset the filter timer once you have replaced the filter.	 Replace Filter	<ul style="list-style-type: none"> Button and icon 4 will initially display as Orange to indicate a new filter should be ordered. Button and icon 4 will turn red when the filter needs to be changed. Pressing button 4 will reset the change filter timer.

CLEANING YOUR REFRIGERATOR

Doors and exterior (white and silver):

You should only clean the doors with lukewarm soapy water and a soft cloth.

Stainless Steel:

Your stainless steel refrigerator is manufactured from mark-resistant stainless steel. This stainless steel has a special advanced protective coating that eases the removal of marks

such as fingerprints and water spots. To keep its appearance, clean it regularly with lukewarm soapy water and a soft cloth.

Interior

Clean the inside of your refrigerator regularly with a soft cloth, unscented mild soap and lukewarm water. Thoroughly dry all surfaces and removable parts and avoid getting water on the controls. Replace removable parts, plug power cord in and switch the power on before returning the food.

Door seals

Always keep door seals clean by washing them with a mild detergent and warm water, followed by a thorough drying. Sticky food and drink can cause seals to stick to the cabinet and tear when you open the door.

Never use hot water, solvents, commercial kitchen cleaners, aerosol cleaners, metal polishes, caustic or abrasive cleaners, or scourers to clean your refrigerator. Many commercially available cleaning products and detergents contain solvents that will damage your refrigerator. Use only a soft cloth with an unscented mild soap and lukewarm water.

Switching off your refrigerator

If you switch off your refrigerator for an extended period, follow these steps to reduce the chances of mould:

1. Remove all food.
2. Remove the power plug from the power point.
3. Thoroughly clean and dry the interior.
4. Ensure that all the doors are wedged open slightly for air circulation.

FOOD STORAGE GUIDE



CATEGORY	PRODUCT	REFRIGERATOR	FREEZER	STORAGE TIPS
Meat	Sausages and Mince	1-2 Days	2-3 Months	Keep cold meat at the back of refrigerator where it is coldest.
	Chops and Steak	3-4 Days	4-6 Months	
	Colei Meats	3-5 Days	4-6 Months	Plastic can cause meat to sweat when stored in refrigerator for more than 2 weeks. Use a clay.
	Cuts for roasting	3-5 Days	12 Months	Cuts for roasting can take up to 24 hours to defrost properly, transfer frozen cuts to the refrigerator 2-3 days before use.
Poultry	Chicken	1-2 Days	2 Months	If poultry takes on a smell or color and you are unsure about it is best to throw it out.
	Roast Chicken	3-5 Days	12 Months	
	Eggs	6 Weeks	Not Suitable	Whole eggs are not suitable for freezing, slightly beaten eggs can be frozen for four months.
Seafood	Whole fish and fillets	2-3 Days	2 Months	Store in an airtight container or vacuum seal.
	Lobster and crabs	1-2 Days	2 Months	Never freeze prawns in salty water as this will dehydrate the flesh.
	Prawns	1-2 Days	2 Months	
Dairy	Milk	Until Expiry Date	Not Suitable	If dairy takes on a smell or color and you are unsure about it, it is best to throw it out.
	Yoghurt	7-10 Days	Not Suitable	
	Hard Cheeses	2 Weeks - 2 Months	2 Months (Grated)	
	Soft Cheeses	1-2 Weeks	Not Suitable	Depending on the variety hard cheese can last from 2 weeks to 12 months.
	Butter	8 Weeks	12 Months	
			8-12 Months	

Fruit & Vegetables	Every fruit and vegetable has a different shelf life.		When freezing chop and blanch in small portions.	Keep vegetables in the crisper away from the air vents to avoid freezing.
	Some stay fresh for a couple of days e.g. beans, others can last for a couple of months e.g. onions.			If you wash fruit and vegetables before storing them make sure they are dry or wrap in absorbent paper before storing in the refrigerator. This can make them susceptible to rotting.
Left Overs	Homemade meals	3-4 Days	2-6 Months	Try to keep fruit and vegetables separated as fruits that give off high levels of ethylene (the ripening agent) can prematurely ripen and spoil surrounding vegetables.
				Store in sealed container. Freeze meals in small portions to limit wastage.

IMPORTANT: Please note, use this information as a guide only, actual storage times will vary depending on how you use your refrigerator, climatic conditions and the freshness of the food. Food should not be left uncovered in the refrigerator.

TROUBLESHOOTING

APPLIANCE DOES NOT OPERATE AT DESIRED TEMPERATURE

In a modern frost free refrigerator/freezer, cold air is circulated around the various compartments through air vents using a high efficiency fan.



CONCERN	WHAT TO DO
Refrigerator is too warm	<p>Ensure food is allowed to cool before placing inside the refrigerator.</p> <p>Ensure the appliance is set up as per instructions on page 11.</p> <p>Ensure that contents are not obstructing the cooling vents.</p> <p>Ensure the door is not held open or is being opened too frequently</p>
Freezer is too warm	<p>Adjust temperature to a colder setting.</p> <p>Ensure food is allowed to cool before placing inside the freezer.</p> <p>Ensure the appliance is set up as per instructions on page 11.</p> <p>Ensure that contents are not obstructing the cooling vents.</p> <p>Ensure the door is not held open or is being opened too frequently</p>
Food is freezing in the refrigerator	<p>Adjust temperature to a warmer setting.</p> <p>Ensure that fruit and vegetables are stored in the crisper. Items with a high water content should not be placed near the cooling vents.</p>
Unable to change temperature settings	<p>Refer to function guide in the "User Interface" section.</p> <p>Ensure that user interface is in "awake" mode before trying to adjust temperature settings.</p>

APPLIANCE NOISE

Your new refrigerator may make sounds that your old one didn't make. Because the sounds are new to you, you might be concerned about them. Most of the new sounds are normal. Hard surfaces, like the floor, walls and cabinets, can make the sounds seem louder than they actually are. The following describes the kinds of sounds and what may be making them.

CONCERN	WHAT TO DO
Motor noise (compressor)	<p>Nothing. This is normal as your new refrigerator uses a high-speed compressor which switches on and off during operation.</p> <p>Note that the compressor noise may seem louder at the start of the on cycle.</p>
A clicking noise heard just before the compressor starts	<p>Nothing. This is normal as your new refrigerator has an automatic switching action of the temperature control, turning the compressor on and off</p>
Occasional gurgling, similar to water boiling.	<p>Nothing. As each cycle ends, you may hear a gurgling sound due to the refrigerant flowing in your refrigerator system</p>
Airflow noise.	<p>Nothing, this is normal as your new refrigerator uses high efficiency fans to circulate air.</p>
Rattling and other noises.	<p>Ensure that the cabinet is level and stable, refer to Installation Instructions on page 6.</p> <p>Check the surrounds of the appliance to ensure there is nothing touching or placed on top of the appliance.</p> <p>Ensure that contents of the appliance are not placed in such a way that they are vibrating (such as bottles).</p>



CRISPER OPERATION

CONCERN	WHAT TO DO
Excess moisture build up in crisper	Ensure that the crisper is not over packed
It is normal for there to be some moisture and humidity in the crisper bin.	Adjust crisper humidity slides.
Crisper bin can not be removed	If crisper bin interferes with the door bins, remove door bins before removing crisper. Position cabinet so that the door can be fully opened
Freezing items in the crisper	Adjust temperature to a warmer setting.



REFRIGERATOR OPERATION

CONCERN	WHAT TO DO
<p>Appliance will not run</p> <p>It is normal for the freezer fan not to operate during the automatic defrost cycle, or for a short time after the appliance is switched on.</p>	<p>Ensure that the cord is plugged into a live power outlet and outlet is switched on.</p> <p>Ensure that the household circuit breaker has not tripped or that the fuse has not blown.</p> <p>The appliance maybe in defrost mode, check again in half an hour</p>
<p>Compressor motor seems to run too long</p> <p>At normal room temperatures, expect your motor to run about 40% to 80% of the time. Under warmer conditions, expect it to run even more often.</p>	<p>Ensure that the doors are not held open.</p> <p>Check that large amounts of warm food have not just been placed inside the appliance.</p> <p>Note that the appliance will run more than normal just after you install it or when adjusting to temperature setting changes.</p>
<p>The exterior of the appliance is warm or hot to touch</p> <p>This is normal because the appliance transfers heat from the inside out through the outer panels and the divider between the doors.</p>	<p>Ensure the appliance has the external clearances recommended in the section "Installing your new appliance".</p> <p>The exterior of the cabinet will be much warmer on warmer days it may even feel hot to touch, as the appliance is working harder.</p>
<p>User interface will not respond</p> <p>To ensure settings are not accidentally changed the user interface will go into sleep mode when not in use. Press any button to wake user interface</p>	<p>Check that the user interface is in awake mode, refer to section "User interface".</p> <p>Check that the user interface is not locked, refer to section "User interface".</p> <p>If the user interface is frozen turn the appliance off for five minutes for the memory to clear, then turn back on.</p>
<p>Alarms Sounding</p>	<p>Check that all doors are fully closed.</p> <p>Ensure that the over temperature alarm is not being activated by hot food placed in the freezer.</p>



CONCERN	WHAT TO DO
	<p>Check if the drinks timer has ended, refer control instructions.</p> <p>Check if the Filter Replacement alert is activated, refer control instructions. (I&W models only)</p>
Frost build up	<p>Check that all doors are fully closed.</p> <p>Ensure that the doors are not opened too often.</p> <p>Ensure that the return air vents are not blocked with packaging.</p> <p>Ensure the seals are clean and not obstructed.</p>
Odours	<p>The interior may need cleaning, refer to cleaning guide.</p> <p>Ensure that food is stored correctly as some food, containers and wrapping can produce odours.</p> <p>Check appliance for old or unusual food.</p>
<p>Lights not working</p> <p>The LED lighting is designed to turn on gradually.</p>	<p>Ensure that the cord is plugged into a live power outlet and outlet is switched on.</p> <p>Ensure that the household circuit breaker has not tripped or that the fuse has not blown.</p> <p>Check the appliance features section to determine lighting configuration for your model.</p>



DOOR OPERATION

CONCERN	WHAT TO DO
Self close not working.	<p>Check if your appliance has self closing hinges as not all models do.</p> <p>It indicates that the appliance needs to be tilted backwards a little further. Refer to section "Installing your new appliance".</p>
Door not sealing properly	<p>Ensure there is nothing that is preventing the door from closing such as appliance contents or items placed near the appliance.</p> <p>Ensure that the crisper/freezer bin is closed completely and that nothing is preventing it from closing.</p> <p>Ensure the appliance is set up as per recommendations.</p>
Door difficult to open and close	<p>If the door is difficult to open just after you have closed it this is due to the pressure equalising, the door will open normally after a few minutes.</p>

AUTOMATIC ICE MAKER



PROBLEM	POSSIBLE CAUSES	SOLUTION
The ice maker is not making any ice	<ul style="list-style-type: none"> • Ice maker is turned OFF 	<ul style="list-style-type: none"> • See Ice maker section in user manual: turn switch to ON position
	<ul style="list-style-type: none"> • Water tap is turned off 	<ul style="list-style-type: none"> • Turn on the water tap.
	<ul style="list-style-type: none"> • The freezer is not cold enough 	<ul style="list-style-type: none"> • See the Problem section: 'If the temperature in the refrigerator is too warm'.
	<ul style="list-style-type: none"> • The water dispenser may not be dispensing water 	<ul style="list-style-type: none"> • If it isn't, the ice & water filter cartridge may be clogged or restricted by foreign material, and will need to be replaced.
	<ul style="list-style-type: none"> • Filter may be blocked 	<ul style="list-style-type: none"> • Check and/or change filter
The ice-maker is not making enough ice	<ul style="list-style-type: none"> • The ice maker is producing less ice than you expect 	<ul style="list-style-type: none"> • The ice maker should produce approximately 0.5-1 kilogram of ice every 24 hours.
	<ul style="list-style-type: none"> • The freezer is not cold enough 	<ul style="list-style-type: none"> • See section 'User Interface'.
	<ul style="list-style-type: none"> • Household water tap is not open 	<ul style="list-style-type: none"> • Open the household water tap.
	<ul style="list-style-type: none"> • The water dispenser is dispensing slower than normal 	<ul style="list-style-type: none"> • Replace the water filter cartridge.
Ice cubes are too small or too big	<ul style="list-style-type: none"> • Restricted water flow to the ice maker 	<ul style="list-style-type: none"> • Replace the filter cartridge, as the water filter cartridge may be clogged.

PROBLEM	POSSIBLE CAUSES	SOLUTION
	<ul style="list-style-type: none"> • Water pressure may be too low 	<ul style="list-style-type: none"> • Check water supply hose for kinks.
	<ul style="list-style-type: none"> • Water pressure may be too high 	<ul style="list-style-type: none"> • Check water pressure meets minimum and maximum requirement (see install instructions).
	<ul style="list-style-type: none"> • Appliance not levelled correctly 	
The ice has a bad odour and taste	<ul style="list-style-type: none"> • The ice has picked up odour or flavour from strongly flavoured food stored in the refrigerator or freezer 	<ul style="list-style-type: none"> • Cover foods tightly. Discard stale ice. The ice maker will produce a fresh supply.
	<ul style="list-style-type: none"> • The water running into the ice maker has poor taste or colour 	<ul style="list-style-type: none"> • Change ice monthly.
	<ul style="list-style-type: none"> • Ice not used frequently enough 	<ul style="list-style-type: none"> • Add or replace water filter to water supply. Consult a water purifying company.
		<ul style="list-style-type: none"> • Discard stale ice monthly.

ICE DISPENSER



PROBLEM	POSSIBLE CAUSES	SOLUTION
<p>The dispenser will not dispense ice</p>	<ul style="list-style-type: none"> • The ice storage container is empty • The ice chute is blocked 	<ul style="list-style-type: none"> • Refer 'the ice maker is not making any ice' section above.
		<ul style="list-style-type: none"> • The first supply of ice may take up to 4 hours after power up, try the dispenser after ice is made.
		<ul style="list-style-type: none"> • Remove ice bin to gain access to chute underneath and remove any ice causing the blockage. Dry the surface of the chute with a paper towel or similar and replace the ice bin ensuring it is fully seated on the door.
		<ul style="list-style-type: none"> • Make sure cups are not over filled with ice during use, causing ice to be trapped in chute
<p>The ice dispenser is jammed</p>	<ul style="list-style-type: none"> • Ice has melted and frozen around the stirrer or in the crusher due to infrequent use, temperature fluctuations and/or power outages. 	<ul style="list-style-type: none"> • Remove the ice bin and empty its contents. Use warm water to melt any ice in the bin and crusher. Leave to dry completely so water does not refreeze in the bin causing a further blockage and refit. Make sure the bin is fully seated on the door. When new ice is made the dispenser should operate.
	<ul style="list-style-type: none"> • Ice cubes are hollow or smaller than normal 	<ul style="list-style-type: none"> • The water filter cartridge could be clogged.
		<ul style="list-style-type: none"> • Cartridge may need replacing.



PROBLEM	POSSIBLE CAUSES	SOLUTION
Water leaking from ice dispenser	<ul style="list-style-type: none"> • Ice trapped and melting in ice chute 	<ul style="list-style-type: none"> • Clear ice chute of ice.
	<ul style="list-style-type: none"> • Ice cubes too small and falling into ice dispenser 	<ul style="list-style-type: none"> • Check ice cube size (refer to the 'Adjusting ice cube size' section).
The flap on the ice dispenser does not close properly	<ul style="list-style-type: none"> • Ice cubes are preventing the flap from closing properly 	<ul style="list-style-type: none"> • Remove ice bin to gain access to the ice chute and remove ice cubes from chute.

If you still require service

If you have a problem, and the problem persists after you have made the checks mentioned, contact your nearest Electrolux approved Service Centre or the dealer you bought the refrigerator from. Be ready to quote the model number, the 9-digit PNC and 8-digit serial number, which is stated on the label inside the refrigerator compartment

Warning

This content is compiled from multiple sources and is provided for reference purposes only. It may not be complete or fully applicable to all situations. If you are unable to resolve your issue, please contact the product manufacturer or an authorized service provider for official support.