

Operating Instructions

Using the surface burners.

How to Light a Surface Burner



Be sure you turn the control knob to OFF when you finish cooking.

Your surface burners are lit by electric ignition, eliminating the need for standing pilot lights with constantly burning flames. Push the control knob in and turn it counterclockwise to the LITE position. After the burner ignites, turn the knob to adjust the flame size. To turn the burner off, turn the knob clockwise as far as it will go, to the OFF position.

- In case of a power failure, you can light the surface burners on your range with a match. Hold a lit match to the burner, then push in and turn the control knob to the LITE position. Use extreme caution when lighting burners this way. Surface burners in use when an electrical power failure occurs will continue to operate normally.
- Do not operate the burner for an extended period of time without cookware on the grate. The finish on the grate may chip without cookware to absorb the heat.
- Check to be sure the burner you turn on is the one you want to use.
- Be sure the burners and grates are cool before you place your hand, a pot holder, cleaning cloths or other materials on them.
- The smaller burner (right rear position) will give the best simmer results. The lowest setting of the burner has a small flame to provide simmering capability. To simmer foods, set the cooktop control knob to the lowest setting that will maintain the desired simmer. If simmering on one burner and the other burners are turned on, the gas flow of the simmering burner may have to be adjusted.

How to Select Flame Size

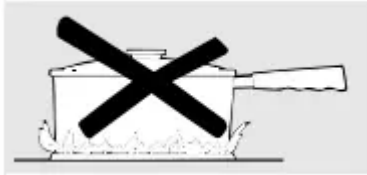

- For safe handling of cookware, never let the flames extend up the sides of the cookware.
- Watch the flame, not the knob, as you reduce heat. The flame size on a gas burner should match the cookware you are using.
- Any flame larger than the bottom of the cookware is wasted and only serves to heat the handle.

Wok This Way



Use a flat-bottomed wok.

- We recommend that you use a flat-bottomed wok, available at your local retail stores, or use the Wok Holder accessory with traditional round bottomed woks.
- The Wok Holder accessory, model JXWK, can be ordered from your appliance dealer. The Wok Holder fits on top of the range grate to provide support and proper air circulation for traditional round bottom woks only. Do not use flat bottomed woks with the Wok Holder. Do not use a wok on any other support ring. Placing the ring over the burner grate may cause the burner to work improperly, resulting in carbon monoxide levels above allowable current standards. This could be dangerous to your health.
- Do not try to use such woks without the ring unless you are using the Wok Holder. You could be seriously burned if the wok tipped over.

Cookware

- Aluminum: Medium-weight cookware is recommended because it heats quickly and evenly. Most foods brown evenly in an aluminum skillet. Use saucepans with tight fitting lids when cooking with minimum amounts of water.
- Enamelware: Under some conditions, the enamel of some cookware may melt. Follow cookware manufacturer's recommendations for cooking methods.
- Glass: There are two types of glass cookware: those for oven use only and those for topof-range cooking (saucepans, coffee and tea pots). Glass conducts heat very slowly.
- Cast Iron: If heated slowly, most skillets will give satisfactory results.

- Heatproof Glass Ceramic: Can be used for either surface or oven cooking. It conducts heat very slowly and cools very slowly. Check cookware manufacturer's directions to be sure it can be used on gas ranges.
- Stainless Steel: This metal alone has poor heating properties and is usually combined with copper, aluminum or other metals for improved heat distribution. Combination metal skillets usually work satisfactorily if they are used with medium heat as the manufacturer recommends.

Using the oven controls.

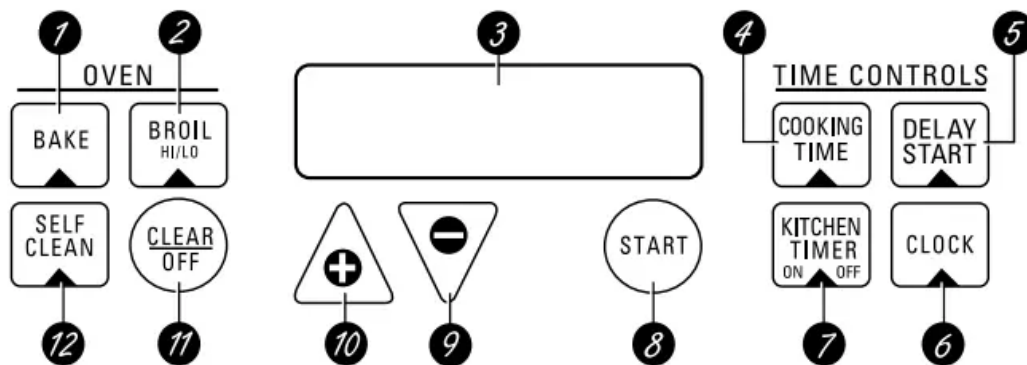

Oven Control, Clock and Timer Features and Settings

1. BAKE Pad: Press this pad to select the bake function.
2. BROIL HI/LO Pad: Press this pad to select the broil function.
3. Display: Shows the time of day and the time set for the timer.
 - If “F— and a number or letter” flash in the display and the oven control signals, this indicates a function error code. Press the CLEAR/OFF pad. Allow the oven to cool for one hour. Put the oven back into operation. If the function error code repeats, disconnect the power to the oven and call for service.
 - If a flashing time of day is in the display, you have experienced a power failure. Reset the clock.
 - If your oven was set for a timed oven operation when the power outage occurred, the clock and all programmed functions must be reset.
 - The time of day will flash in the display when the oven is first turned on.
4. COOKING TIME Pad: Press this pad and then press the INCREASE or DECREASE pads to set the amount of time you want your food to cook. The oven will shut off when the cooking time has run out.
5. DELAY START Pad: Press this pad and the INCREASE or DECREASE pads to delay the starting of your oven up to 9 hours and 59 minutes.

6. CLOCK Pad: Press this pad before setting the clock.
7. KITCHEN TIMER ON/OFF Pad: Press this pad to select the timer feature.
8. START Pad: Must be pressed to start any cooking or cleaning function.
9. DECREASE Pad: Short taps to this pad will decrease the time or temperature by small amounts. Press and hold the pad to decrease the time or temperature by larger amounts.
10. INCREASE Pad: Short taps to this pad will increase the time or temperature by small amounts. Press and hold the pad to increase the time or temperature by larger amounts.
11. CLEAR/OFF Pad: Press this pad to cancel ALL oven operations except the clock and timer.
12. SELF CLEAN Pad: Press this pad to select the self-cleaning function. See the Using the self-cleaning oven section.

Special features of your oven control

Your new touch pad control has additional features that you may choose to use. The following are the features and how you may activate them.

The special feature modes can only be activated while the display is showing the time of day clock. They remain in the control's memory until the steps are repeated.

When the display shows your choice, press the START pad. The special features will remain in memory after a power failure.

12 Hour Shut-Off

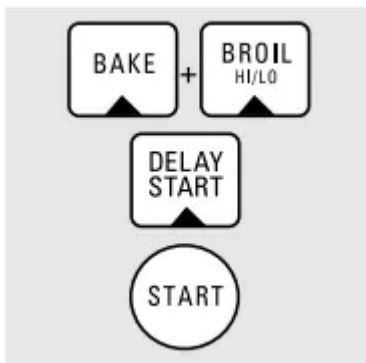

With this feature, should you forget and leave the oven on, the control will automatically turn off the oven after 12 hours during baking functions or after 3 hours during a broil function.

If you wish to turn off this feature, follow the steps below.

1. Press the BAKE and BROIL HI/LO pads at the same time for 3 seconds until the display shows SF. Press the DELAY START pad. The display will show 12 shdn (12 hour shut-off).

2. Press the DELAY START pad again and the display will show no shdn (no shut-off).
3. Press the START pad to activate the no shut-off and leave the control set in this special features mode.

Fahrenheit or Centigrade Temperature Selection

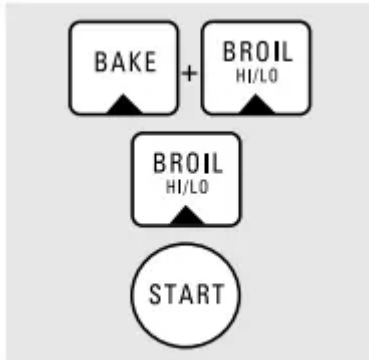

Your oven control is set to use the Fahrenheit temperature selections but you may change this to use the Centigrade selections.

1. Press the BAKE and BROIL HI/LO pads at the same time for 3 seconds until the display shows SF.
2. Press the BROIL HI/LO pad. The display will show F (Fahrenheit).
3. Press the BROIL HI/LO pad again. The display will show C (Centigrade).
4. Press the START pad.

Control Lockout

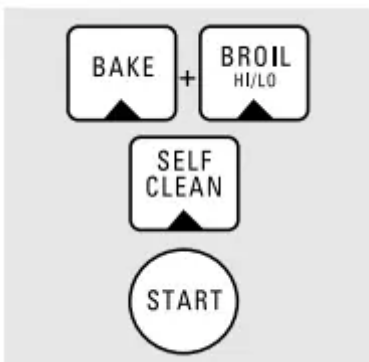

Your control will allow you to lock down the touch pads so they cannot be activated when pressed.

1. Press the BAKE and BROIL HI/LO pads at the same time for 3 seconds until the display shows SF. Press the SELF CLEAN pad. The display will show LOC OFF.
2. Press the SELF CLEAN pad again. The display will show LOC ON.
3. Press the START pad to activate the control lockout feature and leave the control set in this special features mode.

When this feature is on and the touch pads are pressed the control will beep and the display will show LOC.

NOTE: The control lockout mode will not affect the CLOCK and KITCHEN TIMER ON/OFF touch pads.

Tones at the End of a Timed Cycle

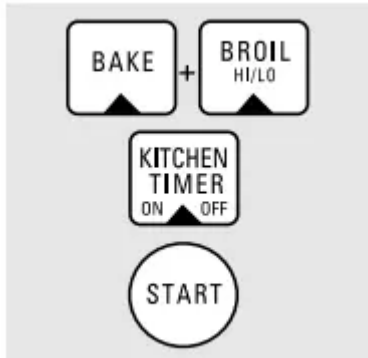

At the end of a timed cycle, 3 short beeps will sound followed by one beep every 6 seconds until the CLEAR/OFF pad is pressed. This continuous 6 second beep may be canceled.

To cancel the 6 second beep:

1. Press the BAKE and BROIL HI/LO pads at the same time for 3 seconds until the display shows SF.
2. Press the KITCHEN TIMER ON/OFF pad. The display shows CON BEEP (continuous beep). Press the KITCHEN TIMER ON/OFF pad again. The display shows BEEP. (This cancels the one beep every 6 seconds.)
3. Press the START pad.

12 Hour, 24 Hour or Clock Black-Out

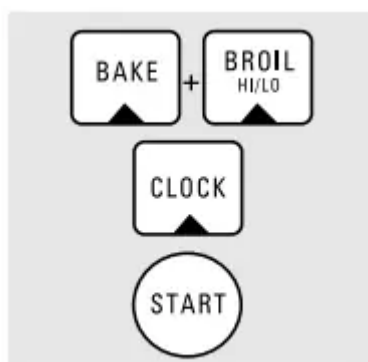

Your control is set to use a 12 hour clock.

If you would prefer to have a 24 hour military time clock or black-out the clock display, follow the steps below.

1. Press the BAKE and BROIL HI/LO pads at the same time for 3 seconds until the display shows SF.
2. Press the CLOCK pad once. The display will show 12 hr. If this is the choice you want, press the START pad.

Press the CLOCK pad again to change to the 24 hour military time clock. The display will show 24 hr. If this is the choice you want, press the START pad.

Press the CLOCK pad again to blackout the clock display. The display will show OFF. If this is the choice you want, press the START pad.

NOTE: If the clock is in the black-out mode you will not be able to use the Delay Start function.

Cook and Hold

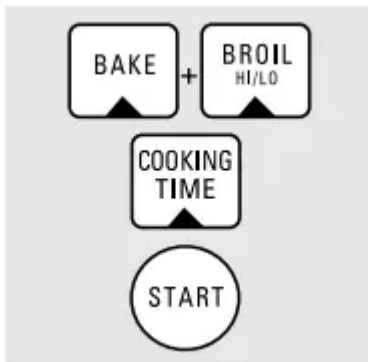

Your new control has a cook and hold feature that keeps cooked foods warm for up to 3 hours after the cooking function is finished.

To activate this feature, follow the steps below.

1. Press the BAKE and BROIL HI/LO pads at the same time for 3 seconds until the display shows SF.
2. Press the COOKING TIME pad. The display will show Hld OFF. Press the COOKING TIME pad again to activate the feature. The display will show Hld ON.
3. Press the START pad to activate the cook and hold feature and leave the control set in this special features mode.

Changing the Speed of the Increase or Decrease Pads

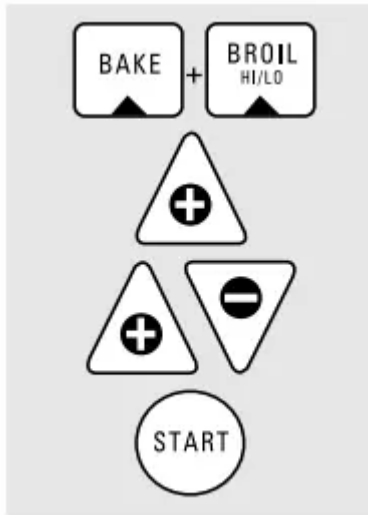

As you use the INCREASE or DECREASE pads when setting a time or temperature, you may notice the display changes slowly. This special feature allows you to change the speed.

To set the speed you prefer, follow the steps below.

1. Press the BAKE and BROIL HI/LO pads at the same time for 3 seconds until the display shows SF.
2. Press the INCREASE pad. The display will show you a set speed between 1 and 5. Press the INCREASE pad to increase the speed up to the number 5.
3. Press the DECREASE pad to decrease the speed down to the number 1.
4. Press START to activate the setting and leave the control set in this special features mode.

Using the oven.

To avoid possible burns, place the shelves in the desired position before you turn the oven on.

Before you begin...

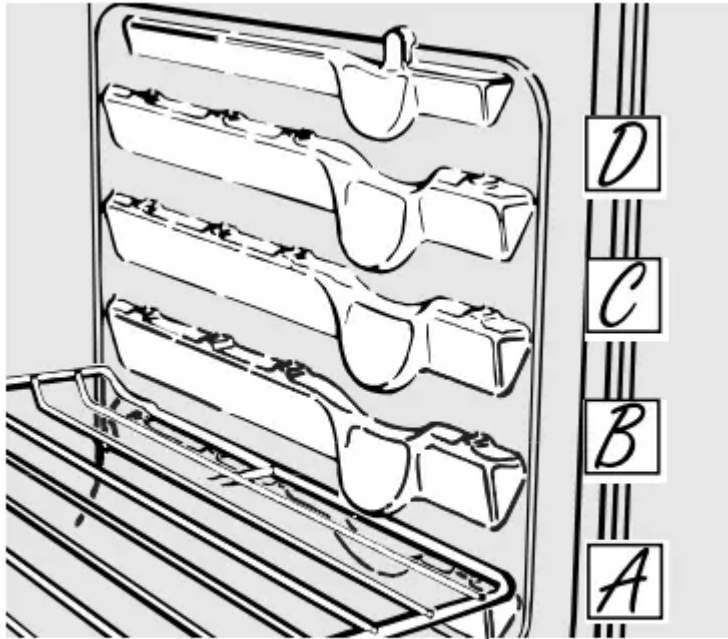

The oven has 4 shelf positions.

- The shelves have stop-locks, so that when placed correctly on the supports, they will stop before coming completely out, and will not tilt.
- When placing and removing cookware, pull the shelf out to the bump on the shelf support.
- To remove a shelf, pull it toward you, tilt the front end up and pull it out.
- To replace, place the end of the shelf (stop-locks) on the support, tilt up the front and push the shelf in.

Electric Ignition

- The oven burner and broil burner are lit by electric ignition.
- To light either burner, press the pad for the desired function and press the INCREASE or DECREASE pad until the desired temperature is displayed. The burner should ignite within 30–90 seconds.
- After the oven reaches the selected temperature, the burner cycles—off completely, then on with a full flame—to keep the oven temperature controlled.

Power Outage

CAUTION: Do not make any attempt to operate the electric ignition oven during an electrical power outage.

- Neither the oven nor the broiler can be lit during an electrical power outage. Gas will not flow unless the glow bar is hot.

- If the oven is in use when a power outage occurs, the oven burner shuts off and cannot be re-lit until power is restored.

Oven Vent



Plastic items on the cooktop may melt if left too close to the vent.

Your oven is vented through ducts at the rear of the range. Do not block these ducts when cooking in the oven—it is important that the flow of hot air from the oven and fresh air to the oven burner be uninterrupted. Avoid touching the vent openings or nearby surfaces during oven or broiler operation—they may become hot.

- Vent openings and nearby surfaces may become hot. Do not touch them.
- Handles of pots and pans on the cooktop may become hot if left too close to the vent.
- Do not leave plastic items on the cooktop— they may melt if left too close to the vent.
- Do not leave any items on the cooktop. The hot air from the vent may ignite flammable items and will increase pressure in closed containers, which may cause them to burst.
- Metal items will become very hot if they are left on the cooktop, and could cause burns.

How to Set the Oven for Baking or Roasting

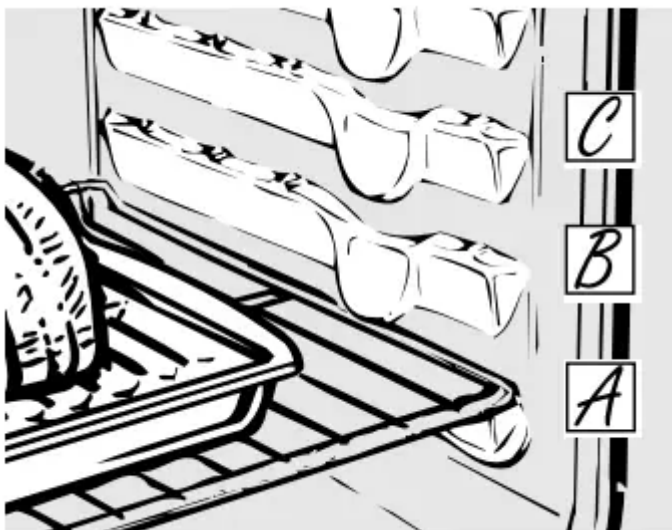

1. Press the BAKE pad.

2. Press the INCREASE or DECREASE pad to set the oven temperature. To change the oven temperature during the Bake cycle, press the BAKE pad and set the new temperature.
3. Press the START pad. When the oven starts to heat, the changing temperature will be in the display. The display starts changing once the temperature reaches 100°F.
4. Press the CLEAR/OFF pad when baking is finished.

NOTE: A cooling fan may automatically turn on and off to cool internal parts. This is normal, and the fan may continue to run even after the oven is turned off.

Type of Food	Shelf Position
Frozen pies (on cookie sheet)	A
Angel food cake, bundt or pound cakes	A or B
Biscuits, muffins, brownies, cookies, cupcakes, layer cakes, pies	B or C
Casseroles	B or C

Preheating and Pan Placement

- Preheat the oven if the recipe calls for it. To preheat, set the oven at the correct temperature. Preheating is necessary for good results when baking cakes, cookies, pastry and breads.
- For ovens without a preheat indicator light or tone, preheat 10 minutes.
- Baking results will be better if baking pans are centered in the oven as much as possible. Pans should not touch each other or the walls of the oven. If you need to use two shelves, stagger the pans so one is not directly above the other, and leave approximately 1 1/2" between pans, from the front, back and sides of the wall.

Aluminum Foil

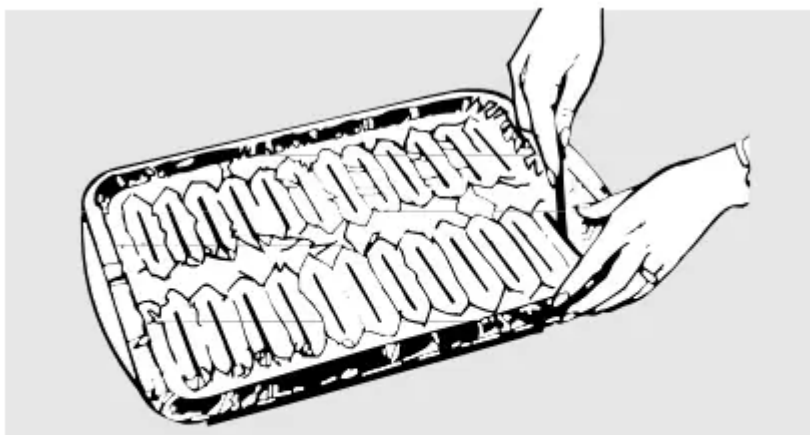

Cut slits in the foil just like the grid.

- You can use aluminum foil to line the broiler pan and broiler grid. However, you must mold the foil tightly to the grid and cut slits in it just like the grid.
- Aluminum foil may also be used to catch a spillover.
- Never entirely cover a shelf with aluminum foil. This will disturb the heat circulation and result in poor baking.
- A smaller sheet of foil may be used to catch a spillover by placing it on a lower shelf several inches below the food.

Oven Moisture

- As your oven heats up, the temperature change of the air in the oven may cause water droplets to form on the door glass.
- These droplets are harmless and will evaporate as the oven continues to heat up

How to Set the Oven for Broiling

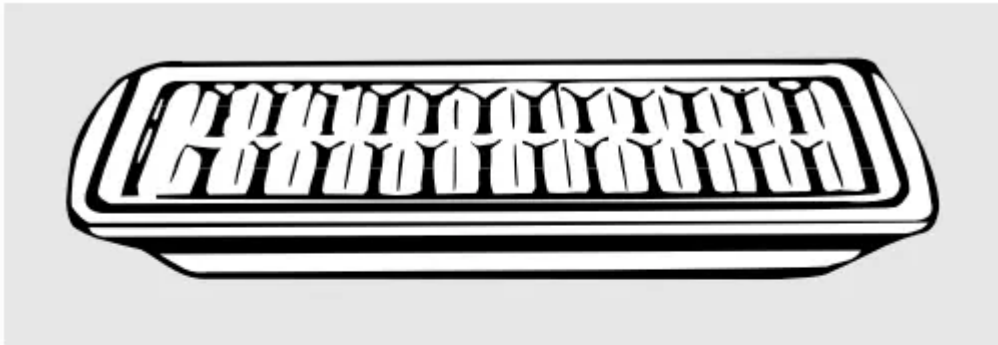

Always use the broiler pan and grid that came with your oven. It is designed to minimize smoking and spattering by trapping juices in the shielded lower part of the pan.

1. Place the meat or fish on the broiler grid in the broiler pan.
2. Follow suggested shelf positions in the Broiling Guide. Broiling should always be done with the oven door closed.
3. Press the BROIL HI/LO pad once for HI Broil. To change to LO Broil, press the BROIL HI/LO pad again.
4. Press the START pad.
5. When broiling is finished, press the CLEAR/OFF pad.

Using the clock and timer.

To Set the Clock



Make sure the clock is set to the correct time of day.

The clock must be set to the correct time of day for the automatic oven timing functions to work properly. The time of day cannot be changed during a timed baking or self-cleaning cycle.

1. Press the CLOCK pad.
2. Press the INCREASE or DECREASE pads.
3. Press the START pad.

To Set the Timer



***The timer is a minute timer only.
The timer does not control oven operations. The maximum setting on the timer is 9 hours and 59 minutes.***

1. Press the KITCHEN TIMER ON/OFF pad.
2. Press the INCREASE or DECREASE pads until the amount of time you want shows in the display. If you make a mistake press the KITCHEN TIMER ON/OFF pad and begin again.
3. Press the START pad.
4. When the timer reaches :00, the control will beep 3 times followed by one beep every 6 seconds until the KITCHEN TIMER ON/OFF pad is pressed.

The 6 second tone can be canceled by following the steps in the Special features of your oven control section under Tones at the End of a Timed Cycle.

To Reset the Timer

- If the display is still showing the time remaining, you may change it by pressing the KITCHEN TIMER ON/OFF pad, then press the INCREASE or DECREASE pads until the time you want appears in the display.
- If the remaining time is not in the display (clock, delay start or cooking time are in the display), recall the remaining time by pressing the KITCHEN TIMER ON/OFF pad and then pressing the INCREASE or DECREASE pads to enter the new time you want.

To Cancel the Timer

- Press the KITCHEN TIMER ON/OFF pad twice.

Using the timed baking and roasting features.

NOTE: Foods that spoil easily—such as milk, eggs, fish, stuffings, poultry and pork—should not be allowed to sit for more than 1 hour before or after cooking. Room temperature promotes the growth of harmful bacteria. Be sure that the oven light is off because heat from the bulb will speed harmful bacteria growth.

The low temperature zone of this range (between 170°F. and 200°F.) is available to keep hot cooked foods warm. Food kept in the oven longer than 2 hours at these low temperatures may spoil.

How to Set an Immediate Start and Automatic Stop

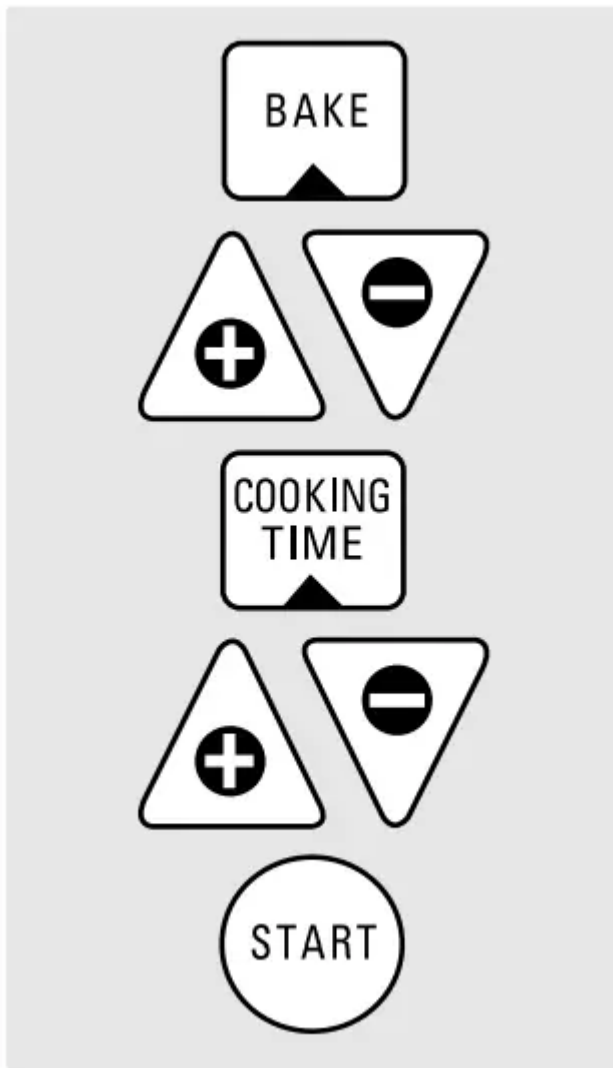

The oven will turn on immediately and cook for a selected length of time. At the end of the cooking time the oven will turn off automatically.

Make sure the clock shows the correct time of day.

1. Press the BAKE pad.
2. Using the INCREASE or DECREASE pads, enter the desired temperature.
3. Press the COOKING TIME pad.
4. Using the INCREASE or DECREASE pads, enter the desired baking time. The oven temperature and the cooking time that you entered will be displayed.
5. Press the START pad.

The display shows the oven temperature that you set and the cooking time countdown.

The display starts changing once the temperature reaches 100°F. The oven will continue to cook for the programmed amount of time, then shut off automatically.

Press the CLEAR/OFF pad to clear the display.

How to Set a Delayed Start and Automatic Stop

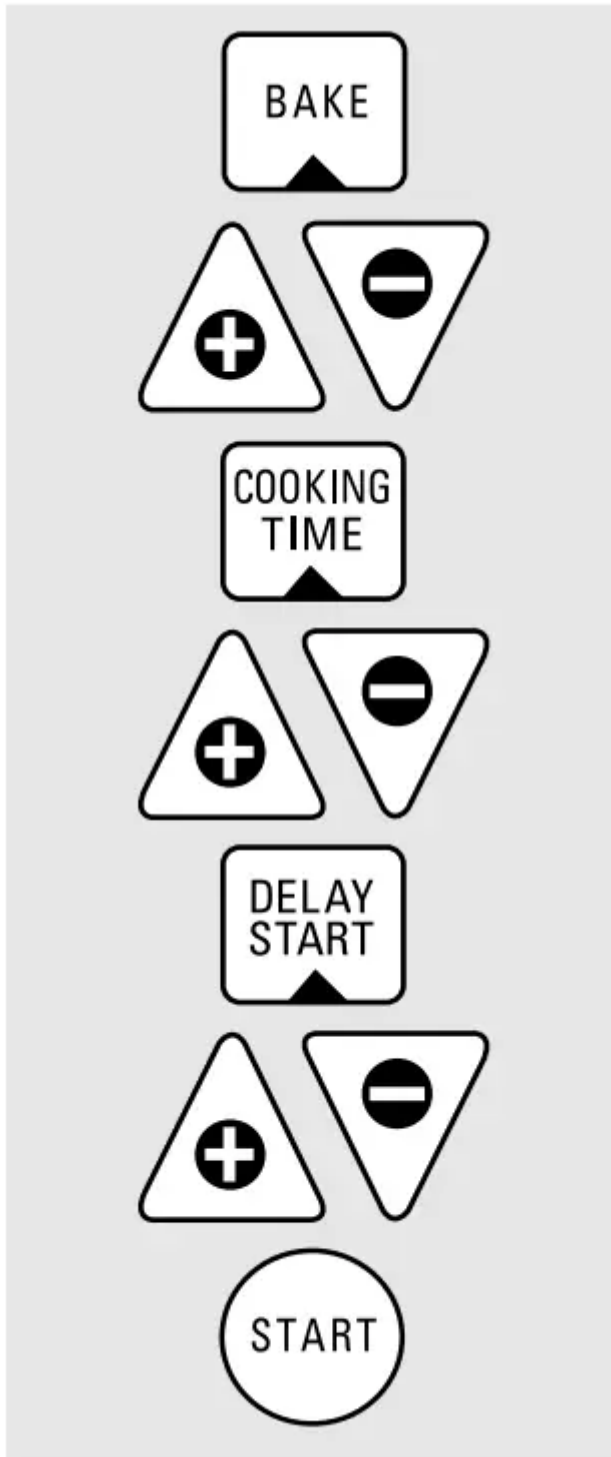

You can set the oven control to delay-start the oven, cook for a specific length of time and then turn off automatically.

Make sure the clock shows the correct time of day.

1. Press the BAKE pad.
2. Using the INCREASE or DECREASE pads, enter the desired temperature.

3. Press the COOKING TIME pad.
4. Using the INCREASE or DECREASE pads, enter the desired baking time.
5. Press the START TIME pad.
6. Using the INCREASE or DECREASE pads, enter the time of day you want the oven to turn on and start cooking.
7. Press the START pad.

NOTE: An attention tone will sound if you are using timed baking and do not press the START pad after entering the baking temperature.

If you would like to check the times you have set, press the DELAY START pad to check the start time you have set or press the COOKING TIME pad to check the length of cooking time you have set.

When the oven turns on at the time of day you have set, the display will show the changing temperature (starting at 100°F.) and the cooking time countdown.

At the end of timed baking, the oven will turn off. The end of cycle tone will sound.

Press the CLEAR/OFF pad to clear the display

Adjust the oven thermostat—Do it yourself!

You may find that your new oven cooks differently than the one it replaced. Use your new oven for a few weeks to become more familiar with it. If you still think your new oven is too hot or too cold, you can adjust the thermostat yourself.

Do not use thermometers, such as those found in grocery stores, to check the temperature setting of your oven. These thermometers may vary 20–40 degrees.

NOTE: This adjustment will not affect the broiling or the self-cleaning temperatures. The adjustment will be retained in memory after a power failure.

To Adjust the Thermostat

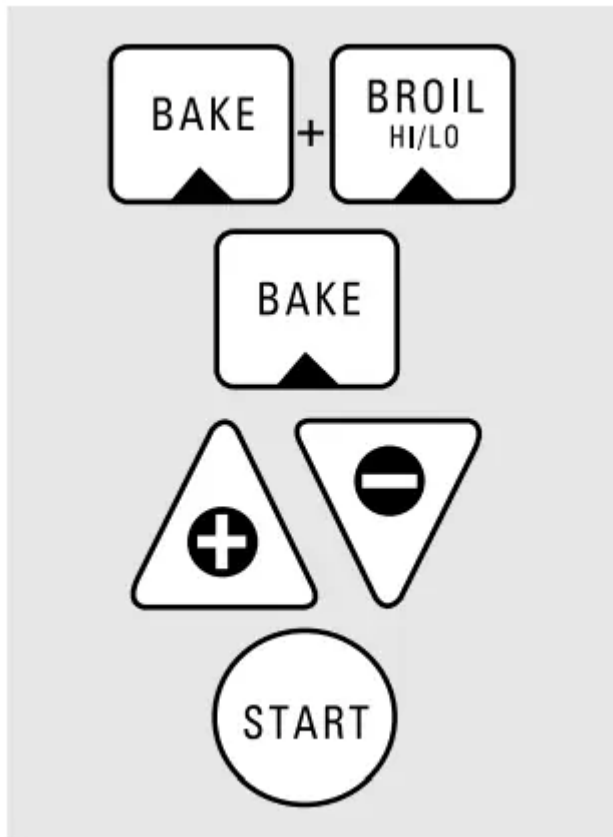

1. Press the BAKE and BROIL HI/LO pads at the same time for 3 seconds until the display shows SF.
2. Press the BAKE pad. A two digit number shows in the display.
3. The oven temperature can be adjusted up to (+) 35°F. hotter or (-) 35°F. cooler. Press the INCREASE pad to increase the temperature in 1 degree increments. Press the DECREASE pad to decrease the temperature in 1 degree increments.
4. When you have made the adjustment, press the START pad to go back to the time of day display. Use your oven as you would normally

The type of margarine will affect baking performance!

- Most recipes for baking have been developed using high fat products such as butter or margarine (80% fat). If you decrease the fat, the recipe may not give the same results as with a higher fat product.
- Recipe failure can result if cakes, pies, pastries, cookies or candies are made with low fat spreads. The lower the fat content of a spread product, the more noticeable these differences become.
- Federal standards require products labeled “margarine” to contain at least 80% fat by weight. Low fat spreads, on the other hand, contain less fat and more water. The high moisture content of these spreads affect the texture and flavor of baked goods. For best

results with your old favorite recipes, use margarine, butter or stick spreads containing at least 70% vegetable oil.

Using the self-cleaning oven.

The oven door must be closed and all controls must be set correctly for the cycle to work properly.

Before a Clean Cycle



Wipe up heavy soil on the oven bottom.

- The oven must be completely cool in order to set the self-clean cycle.
- We recommend venting your kitchen with an open window or using a ventilation fan or hood during the first self-clean cycle.
- Remove the broiler pan, broiler grid, all cookware and any aluminum foil from the oven.
- The oven shelves can be self-cleaned, but they will darken, lose their luster and become hard to slide.
- Do not use abrasives or oven cleaners. Clean the top, sides and outside of the oven door with soap and water.
- Make sure the oven light bulb cover (on some models) is in place and the Wipe up heavy soil on the oven oven light is off.

How to Set the Oven for Cleaning



1. Press the SELF CLEAN pad.
2. Using the INCREASE or DECREASE pads, enter the desired clean time, if a time other than 4 hours is needed. Clean cycle time is normally 4 hours. You can change the clean time to any time between 3 hours and 5 hours, depending on how dirty your oven is.
3. Press the START pad.

The door locks automatically. The display will show the clean time remaining. It will not be possible to open the oven door until the temperature drops below the lock temperature and the LOCKED DOOR light goes off.

When the LOCKED DOOR light is off, open the door.

- The words LOCK DOOR will flash and the oven control will signal if you set the clean cycle and forget to close the oven door.
- To stop a clean cycle, press the CLEAR/OFF pad. When the LOCKED DOOR light goes off and the oven has cooled below the locking temperature, open the door.

How to Delay the Start of Cleaning



1. Press the SELF CLEAN pad.
2. Using the INCREASE or DECREASE pads, enter the desired clean time.
3. Press the DELAY START pad. The earliest start time you can set will appear in the display.
4. Using the INCREASE or DECREASE pads, enter the time of day you want the clean cycle to start.
5. Press the START pad.

The door locks automatically. The display will show the start time. It will not be possible to open the oven door until the temperature drops below the lock temperature and the LOCKED DOOR light goes off.

When the LOCKED DOOR light is off, open the door.

After a Clean Cycle

You may notice some white ash in the oven. Wipe it up with a damp cloth after the oven cools.

If white spots remain, remove them with a soapfilled steel wool pad and rinse thoroughly with a vinegar and water mixture.

These deposits are usually a salt residue that cannot be removed by the clean cycle.

If the oven is not clean after one clean cycle, repeat the cycle.

- You cannot set the oven for cooking until the oven is cool enough for the door to unlock.
- While the oven is self-cleaning, you can press the CLOCK pad to display the time of day. To return to the clean countdown, press the SELF CLEAN pad.
- If the shelves become hard to slide, wipe the shelf supports with cooking oil.

Care and Cleaning

Be sure electrical power is off and all surfaces are cool before cleaning any part of the range.

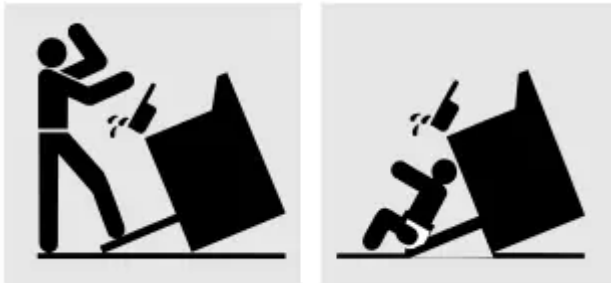

If your range is removed for cleaning, servicing or any reason, be sure the anti-tip device is re-engaged properly when the range is replaced. Failure to take this precaution could result in tipping of the range and cause injury

How to Remove Packaging Tape

- To assure no damage is done to the finish of the product, the safest way to remove the adhesive left from packaging tape on new appliances is an application of a household liquid dishwashing detergent, mineral oil or cooking oil.
- Apply with a soft cloth and allow to soak. Wipe dry and then apply an appliance polish to thoroughly clean and protect the surface.

NOTE: The plastic tape must be removed from all chrome trim. It cannot be removed if it is baked on.

Control Knobs

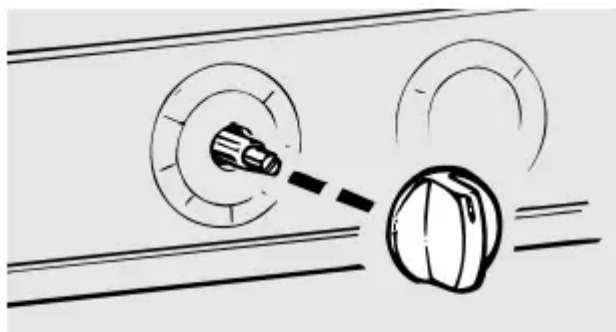

Pull the knob straight off the stem.

- Clean up spatters with a damp cloth. Remove heavier soil with warm, soapy water.
- Do not use abrasives of any kind on the control panel.
- The control knobs may be removed for easier cleaning. To remove a knob, pull it straight off the stem. Wash the knobs in soap and water but do not soak.

Burner Assembly

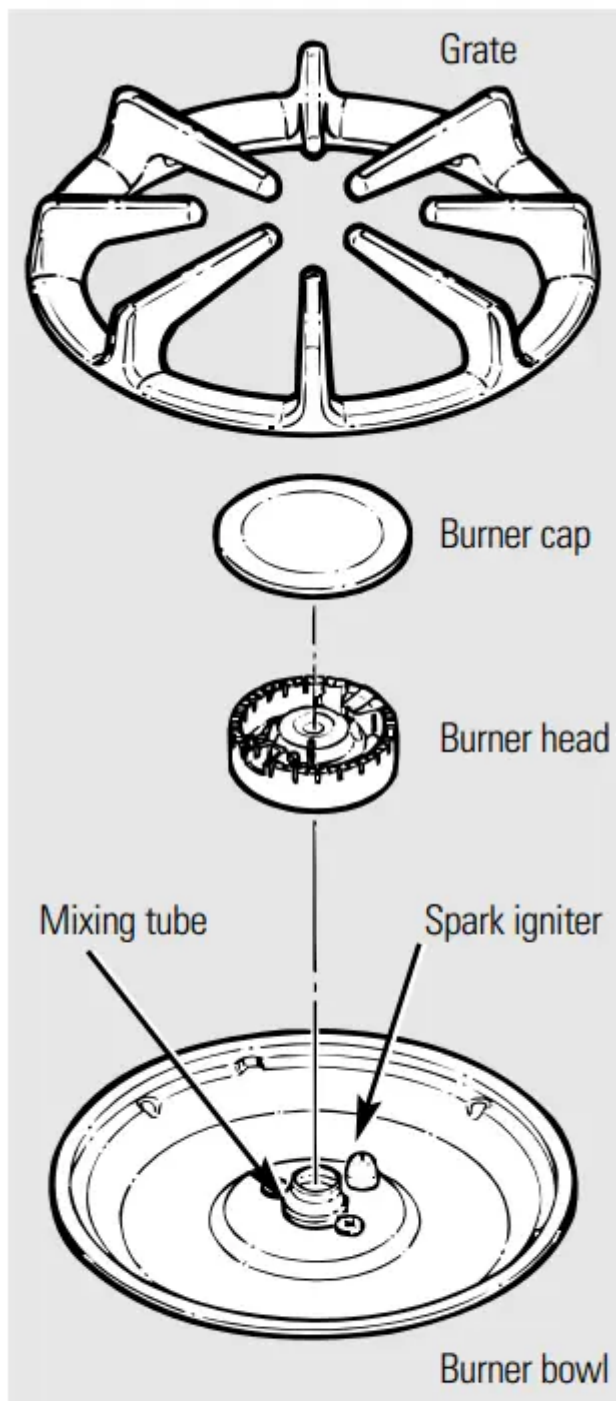

CAUTION: DO NOT OPERATE THE BURNER WITHOUT ALL BURNER PARTS IN PLACE.

- The burner assemblies should be washed regularly and, of course, after spillovers. Turn all controls off before removing burner parts.

- The burner grates, burner heads and burner caps can be removed for easy cleaning. Removing them gives you access to the burner bowls.
- The electrode of the spark igniter is exposed beyond the surface of the burner bowl. When cleaning the burner bowl, be careful not to snag the electrode of the spark igniter with your cleaning cloth. Damage to the igniter could occur. To avoid snagging a cloth on the spark igniter, leave the burner heads in place when cleaning the burner bowls.
- Be careful not to push in any cooktop controls while cleaning the burner bowls. A slight electrical shock might result which could cause you to knock over hot cookware.
- Wash burner parts with an all-purpose non-abrasive cleaner and warm water. Soak stubborn soil. Dry them with a cloth—do not reassemble while wet.
- If the igniter orifice gets dirty or clogged you may use a small sewing needle to remove the soil.
- To reassemble, replace the burner head first, then the burner cap and finally the burner grate.

Burner Grates

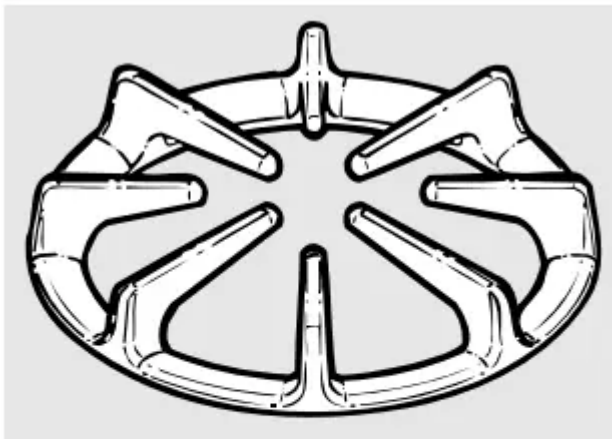

When replacing the grates, be sure they're positioned securely over the burners.

- Porcelain enamel burner grates should be washed regularly and, of course, after spillovers.
- Wash them in hot, soapy water and rinse with clean water. You may also use abrasive cleaners and steel wool pads to clean burner grates. Dry the grates with a cloth— don't put them back on the range wet.

- To get rid of burned-on food, place the grates in a covered container or plastic bag. Add 1/4 cup ammonia and let them soak several hours or overnight. Wash, rinse well, and dry.
- To prevent rusting, apply a light coating of cooking oil to the grates.
- Although they're durable, the grates will gradually lose their shine, regardless of the best care you can give them. This is due to their continual exposure to high temperatures.
- Do not operate a burner for an extended period of time without cookware on the grate. The finish on the grate may chip without cookware to absorb the heat.

Porcelain Enamel Cooktop (on some models)

- The porcelain enamel finish is sturdy but breakable if misused. This finish is acidresistant. However, any acidic foods spilled (such as fruit juices, tomato or vinegar) should not be permitted to remain on the finish.
- If acids spill on the cooktop while it is hot, use a dry paper towel or cloth to wipe it up right away. When the surface has cooled, wash with soap and water. Rinse well.
- For other spills such as fat splatterings, wash with soap and water or cleansing powders after the surface has cooled. Rinse well. Polish with a dry cloth.

Glass Cooktop (on some models)

- To keep the cooktop looking its best, wipe up any spills as they occur. This will keep them from burning on and becoming more difficult to remove.
- As soon as the cooktop is cool, wash the glass surface with a cloth moistened with warm, soapy water; rinse with clean water, and dry with a soft cloth. You can use any liquid household detergent.
- Do not use abrasive materials such as metal pads, cleansing powder and scouring pads—they may scratch the surface.
- Do not use harsh chemicals such as bleach or chemical oven cleaners.

CAUTION: Do not cook on or clean a broken or cracked cooktop. Cleaning solutions and spillovers penetrating the cooktop can create a risk of electric shock. Call for a service technician immediately.

Oven Shelves

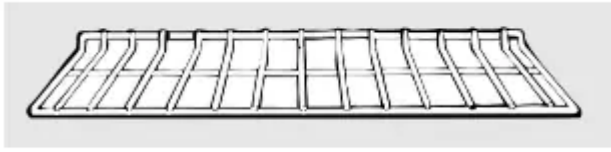

- Clean the oven shelves with an abrasive cleanser or steel wool. After cleaning, rinse the shelves with clean water and dry with a clean cloth.

NOTE: The oven shelves may be cleaned in the self-cleaning oven. However, the shelves will darken in color, lose their luster and become hard to slide if cleaned during the self-cleaning cycle. You can wipe the shelf supports with cooking oil after self-cleaning to make the shelves slide more easily

Oven Vent

- The oven is vented through an opening at the rear of the cooktop.
- Never cover the opening with aluminum foil or any other material. This would prevent the oven vent from working properly.
- The vent grille may discolor during selfcleaning. Clean the oven vent grill with a non-abrasive cleaner such as Bon Ami®.

Lift-Off Oven Door

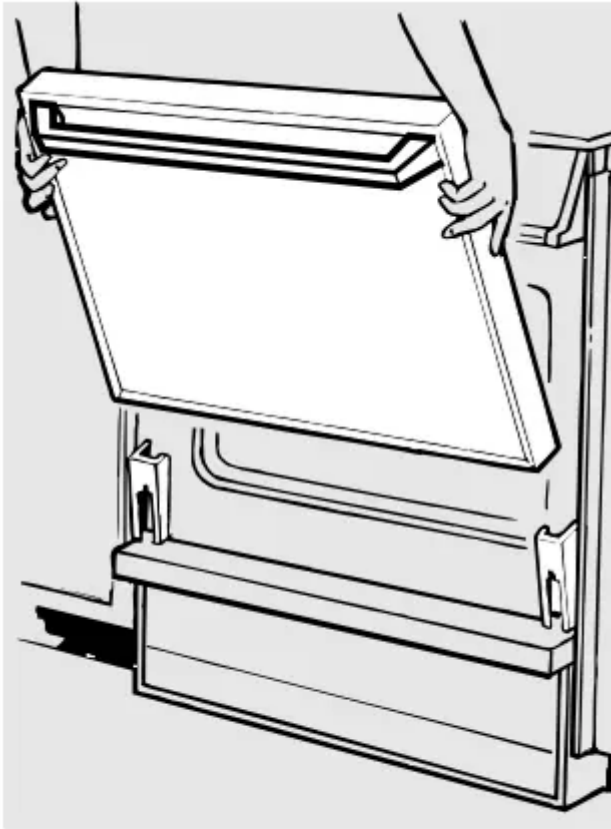

Lift the door straight up and off the hinges.

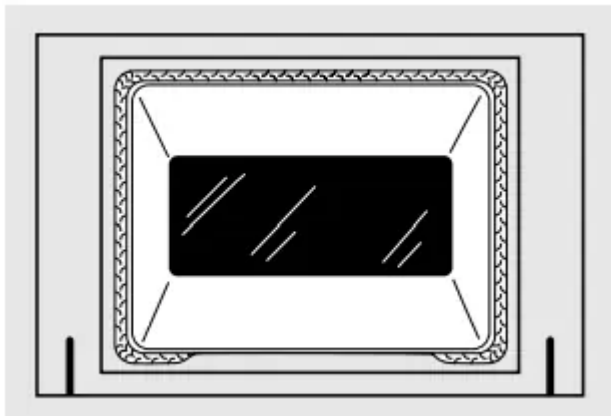

(appearance may vary)

The gasket is designed with a gap at the bottom to allow for proper air circulation.

Do not rub or clean the door gasket—it has an extremely low resistance to abrasion.

If you notice the gasket becoming worn, frayed or damaged in any way or if it has become displaced on the door, you should have it replaced.

The oven door is removable for cleaning.

Do not lift the door by the handle.

To remove the door, open it to the special stop position. Grasp firmly on each side and lift the door straight up and off the hinges.

Do not place hands between the hinge and the oven door frame.

To replace the door, make sure the hinges are in the special stop position. Position the slots in the bottom of the door squarely over the hinges and slowly lower it over both hinges.

To clean the inside of the door:

- Because the area inside the gasket is cleaned during the self-clean cycle, you do not need to clean this by hand.
- The area outside the gasket and the front frame can be cleaned with a soappilled steel wool or plastic pad, hot water and detergent. Rinse well with a vinegar and water solution.

To clean the outside of the door:

- Use soap and water to thoroughly clean the top, sides and front of the oven door. Rinse well. You may also use a glass cleaner to clean the glass on the outside of the door. Do not let water drip into the vent openings.
- Spillage of marinades, fruit juices, tomato sauces and basting materials containing acids may cause discoloration and should be wiped up immediately. When surface is cool, clean and rinse.
- Do not use oven cleaners, cleaning powders or harsh abrasives on the outside of the door

Removable Storage Drawer

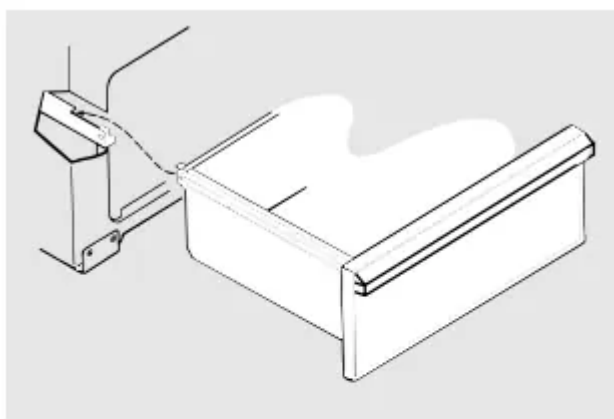

The storage drawer may be removed for cleaning under the range.

The storage drawer is a good place to store cookware and bakeware. Do not store plastics and flammable material in the drawer.

Do not overload the storage drawer. If the drawer is too heavy, it may slip off the track when opened. To open the drawer, grasp the center of the handle and pull straight out.

To remove: Pull the drawer straight out and lift over the guide stops.

To replace:

- Lift over the guide stops and slide the drawer into place.
- To clean both the inside and the outside: Wipe with soap and water. Rinse well.
- Do not use cleansing powders or harsh abrasives which may scratch the surface.

Painted Surfaces

- Painted surfaces include the sides and the drawer front.
- Clean these with soap and water or a vinegar and water solution.
- Do not use commercial oven cleaners, cleaning powders, steel wool or harsh abrasives on any painted surface.

Broiler Pan & Grid

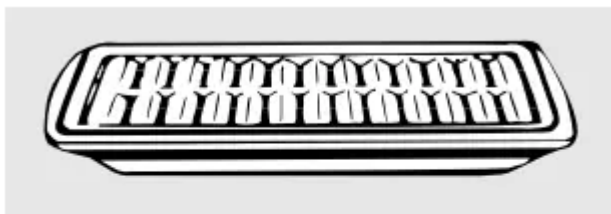

After broiling, remove the broiler pan from the oven.

- Do not clean the broiler pan or grid in a selfcleaning oven.
- After broiling, remove the broiler pan from the oven. Remove the grid from the pan. Carefully pour out the grease from the pan into a proper container.
- Wash and rinse the broiler pan and grid in hot water with a soap-filled or plastic scouring pad.
- If food has burned on, sprinkle the grid with detergent while hot and cover with wet paper towels or a dishcloth. Soaking the pan will remove burned-on foods.
- Both the broiler pan and grid may be cleaned with a commercial oven cleaner.
- Both the broiler pan and grid can also be cleaned in a dishwasher.

- Do not store a soiled broiler pan and grid anywhere in the range.

Oven Light Bulb

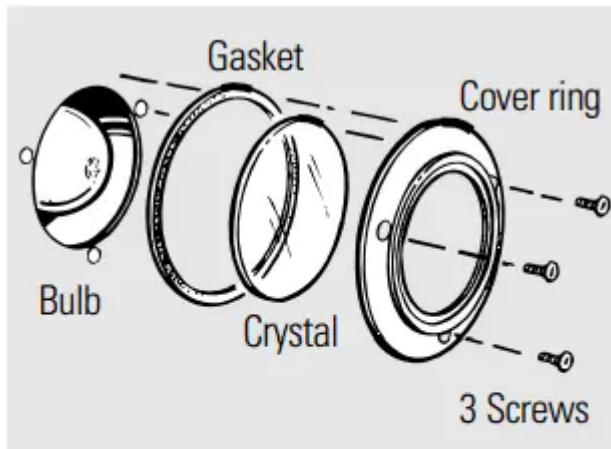

The light cover assembly has a cover ring, crystal and gasket. It is held in place with 3 screws.

The light bulb is located on the back oven wall. Before replacing the bulb, disconnect the electric power to the range at the main fuse or circuit breaker panel or unplug the range from the electric outlet.

Let the bulb cool completely before removing it. Do not touch a hot bulb with a damp cloth. If you do, the bulb will break

To remove:

1. Remove the 3 screws in the cover ring.
2. Detach the light cover assembly and remove the bulb.

To replace:

1. Put in a new 40-watt appliance bulb. NOTE: A 40-watt appliance bulb is smaller than a standard 40-watt household bulb.
2. Install the light cover assembly. Replace the 3 screws and tighten, making sure the cover fits flush with the oven wall.
3. Reconnect the electric power to the range.

Removable Oven Bottom

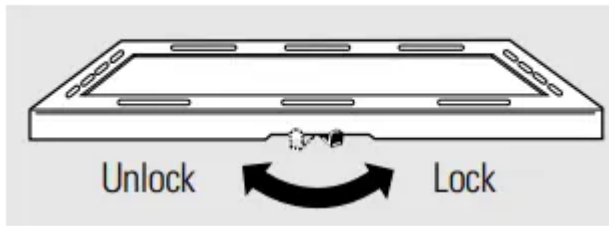

The tab at the center front of the oven bottom slides left to unlock and right to lock.

The oven bottom can be removed to clean large spills, and to enable you to reach the oven burner.

The oven bottom must be replaced before using the self-clean cycle.

To remove:

1. Slide the tab at the center front of the oven bottom to the left.
2. Lift the oven bottom up and out.

To replace:

1. Slip the oven bottom into the oven so the tabs in the rear of the oven bottom fit into the slots in the oven back.
2. Lower the front of the oven bottom into place and slide the front tab to the right to lock the oven bottom into place.

The oven bottom has a porcelain enamel finish. To make cleaning easier, protect the oven bottom from excessive spillovers.

Hot fruit fillings or foods that are acidic (such as tomatoes or sauerkraut, and sauces with vinegar or lemon juice) may cause pitting and damage to the porcelain enamel surface.

To protect the oven bottom surface, place a piece of aluminum foil slightly larger than the baking dish or a small cookie sheet on a lower shelf or under the baking dish to catch any spillovers.

Do not completely cover a shelf with aluminum foil as this would cause uneven heat in the oven. Aluminum foil should not be placed on the oven bottom.

If a spillover does occur on the oven bottom, allow the oven to cool first. You can clean the oven bottom with soap and water, a mild abrasive cleanser or soapfilled abrasive pads. Rinse well to remove any soap before self-cleaning

If the range is removed for cleaning or any reason, make sure the chain is reattached.

Anti-Tip Device

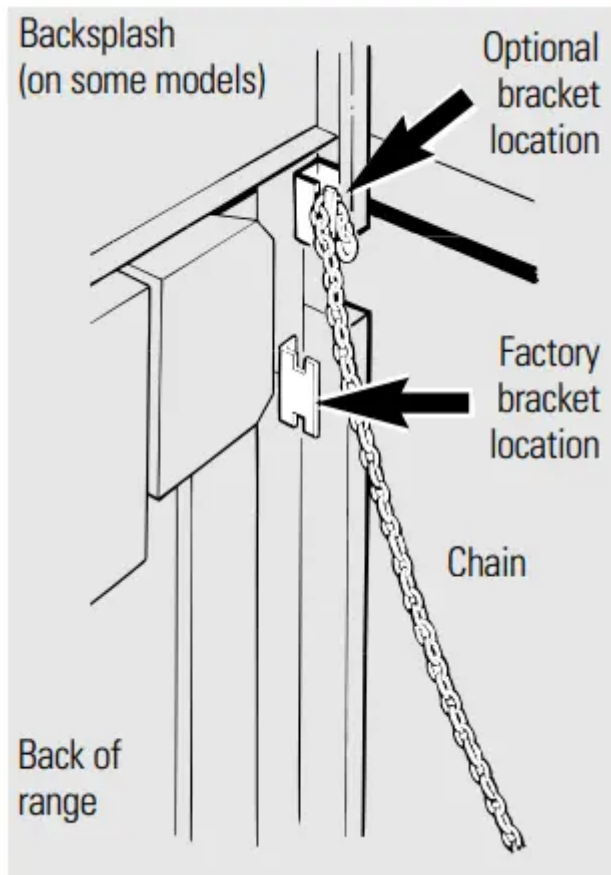

1. Before placing range in the counter, notice the location of the stability bracket which is already attached to the back of the range. This location should work for most installations. However, it may be more convenient to hook the stability chain to the unit when the stability bracket is attached to the upper set of holes in the back of range.

The upper level set of holes is intended for use with a backsplash kit. If the backsplash is not being used, make sure that there are no structural supports for the countertop which will interfere with the stability bracket when located in the upper set of holes.

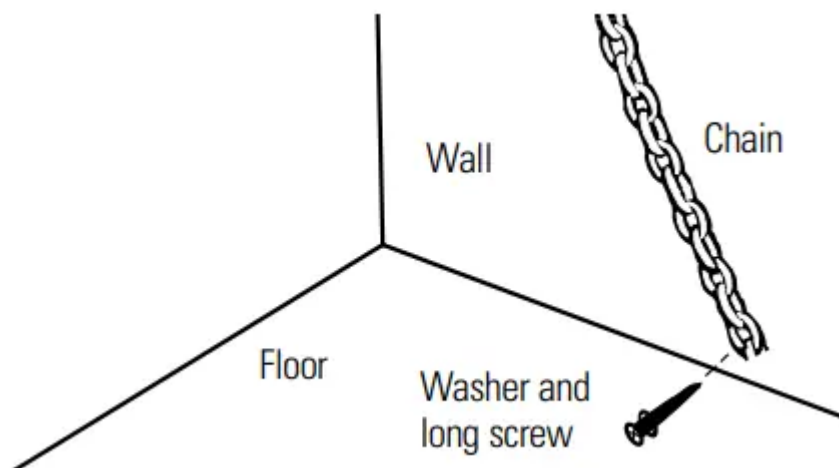

2. Fasten one end of the stability chain to the floor or wall with the long screw and washer supplied.

NOTE: If attaching to masonry, you can buy suitable screws and anchors at hardware stores. Use a masonry drill to drill the required holes.

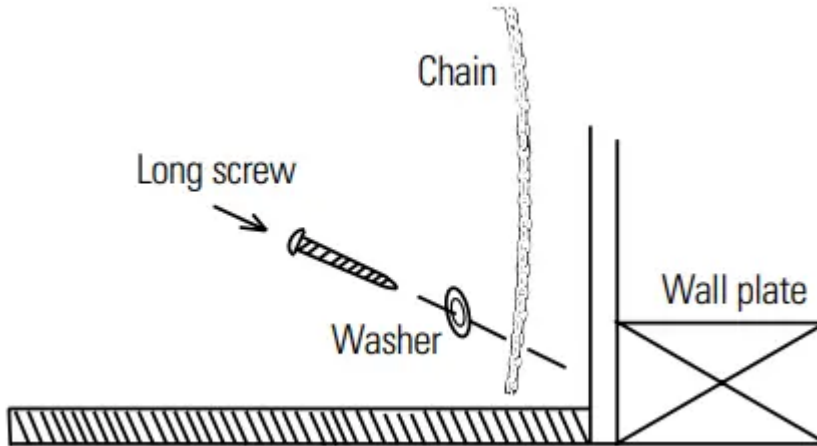

Make certain the screw is going into the wall plate at the base of the wall or one of the studs in the base of the wall.

Whether you attach the chain to the wall or floor, be certain that the screw is in at least 3/4 inch thickness of wood other than baseboard and that there are no electrical wires or plumbing in the area which the screw could penetrate. Attach the stability chain in a location which will allow the chain to be in line with the bracket side to aide as much as possible when attached to the unit. Test to see if the chain is securely fastened by tugging on the chain.

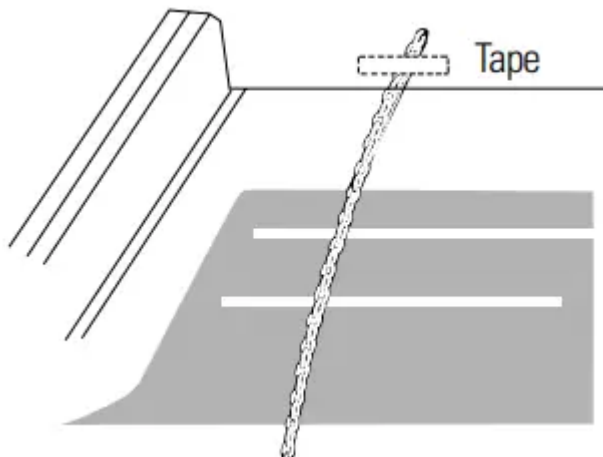

3. Temporarily attach the loose end of the chain to the rear of the countertop with the tape from the packaging.

4. Place the range in the counter cutout leaving just enough room between the back of the range and the wall to reach the stability bracket.

5. Hook the loose end of the chain onto the bracket by slipping the nearest link of the chain into the slot in the bracket. Make sure the chain is pulled as tight as possible and that there is no excess slack in the chain after the chain is attached to the bracket.

6. Slide the range all the way back into the counter. Once the range is pushed back in place, there will be a small amount of slack in the chain. This is normal.

CAUTION: Excessive slack in the chain could allow the range to tip over

Control Panel

- It's a good idea to wipe the control panel after each use. Clean with mild soap and water or vinegar and water, rinse with clean water and polish dry with a soft cloth.
- Do not use abrasive cleansers, strong liquid cleansers, plastic scouring pads or oven cleansers on the control panel—they will damage the finish. A 50/50 solution of vinegar and hot water works well.

Troubleshooting Tips

Before You Call For Service...

Problem	Possible Causes	What To Do
Burners have yellow or yellow-tipped flames	The combustion quality of burner flames needs to be determined visually.	<ul style="list-style-type: none"> Use the illustrations below to determine if your burner flames are normal. If burner flames look like A, call for service. Normal burner flames should look like B or C, depending on the type of gas you use. With LP gas, some yellow tipping on outer cones is normal <div data-bbox="1027 555 1497 707" style="text-align: center;">  <p> A—Yellow flames <i>Call for service</i> </p> <p> B—Yellow tips on outer cones <i>Normal for LP gas</i> </p> <p> C—Soft blue flames <i>Normal for natural gas</i> </p> </div>
Surface burner knobs will not turn	Surface controls improperly set.	<ul style="list-style-type: none"> To turn from the OFF position, push the knob in and then turn.
Surface burners do not light	Plug on range is not completely inserted in the electrical outlet.	<ul style="list-style-type: none"> Make sure electrical plug is plugged into a live, properly grounded outlet.
	Gas supply not connected or turned on.	<ul style="list-style-type: none"> See the Installation Instructions that came with your range.
	A fuse in your home may be blown or the circuit breaker tripped.	<ul style="list-style-type: none"> Replace the fuse or reset the circuit breaker.
	Pan sitting on burner grate may be partially blocking the free air flow needed for combustion.	<ul style="list-style-type: none"> Remove the pan and try again.
	Igniter orifice in burner body may be clogged.	<ul style="list-style-type: none"> Remove the obstruction. See the Care and cleaning of the range section.
	Burner parts not replaced correctly.	<ul style="list-style-type: none"> See the Care and cleaning of the range section.
Hole in burner top behind the igniter may be clogged.	<ul style="list-style-type: none"> Use a small sewing needle to unplug. 	
	Surface control knob is still in the LITE position.	<ul style="list-style-type: none"> Turn the knob out of the LITE position to the desired setting.



Ticking sound of spark igniter persists after burner lights		<ul style="list-style-type: none"> • Turn the burner off and relight. If ticking is still present, call for service.
Ticking sound persists after burner is turned off	Be sure the knob is in the OFF position.	<ul style="list-style-type: none"> • Remove knob by pulling it straight off the stem and check the bottom of the knob for any build-up of soil.
Burner flames very large or yellow	Improper air to gas ratio.	<ul style="list-style-type: none"> • If range is connected to LP gas, check all steps in the Installation Instructions that came with your range.
Oven will not work but cooktop does	Oven shut-off valve is in the closed position.	<ul style="list-style-type: none"> • Locate the oven shut-off valve on the pressure regulator located behind the storage drawer (see the Installation Instructions). Move the shut-off lever to the open position.
Clock and timer do not work	A fuse in your home may be blown or the circuit breaker tripped.	<ul style="list-style-type: none"> • Replace the fuse or reset the circuit breaker.
	Oven controls improperly set.	<ul style="list-style-type: none"> • See the Using the clock and timer section.
Oven light does not work	Light bulb is loose or defective	<ul style="list-style-type: none"> • Tighten or replace the bulb.
	Plug on range is not completely inserted in the electrical outlet	<ul style="list-style-type: none"> • Make sure electrical plug is plugged into a live, properly grounded outlet
	Switch operating light is broken.	<ul style="list-style-type: none"> • Call for service.
Oven temperature too hot or too cold	Oven thermostat needs adjustment.	<ul style="list-style-type: none"> • See the Adjust the oven thermostat—Do it yourself! section.
Oven will not work	A fuse in your home may be blown or the circuit breaker tripped.	<ul style="list-style-type: none"> • Replace the fuse or reset the circuit breaker.
	Oven controls improperly set.	<ul style="list-style-type: none"> • See the Using the oven section.



Control signals after entering cooking time or delay start	You forgot to enter a bake temperature or cleaning time.	<ul style="list-style-type: none"> • Press the BAKE pad and desired temperature or the SELF CLEAN pad and desired clean time.
Display goes blank	A fuse in your home may be blown or the circuit breaker tripped.	<ul style="list-style-type: none"> • Replace the fuse or reset the circuit breaker.
	The clock is in the black-out mode.	<ul style="list-style-type: none"> • See the Special features of your oven control section.
Food does not broil properly	Oven door not closed.	<ul style="list-style-type: none"> • See the Using the oven section.
	Oven controls improperly set.	<ul style="list-style-type: none"> • Make sure you press the BROIL HI/LO pad.
	Improper shelf position being used.	<ul style="list-style-type: none"> • See the Broiling Guide.
	Cookware not suited for broiling.	<ul style="list-style-type: none"> • Use the broiling pan and grid that came with your oven.
	Aluminum foil used on the broiling pan and grid has not been fitted properly and slit as recommended.	<ul style="list-style-type: none"> • See the Using the oven section.
	Oven bottom not securely seated in position.	<ul style="list-style-type: none"> • See the Care and cleaning of the range section.
Food does not bake or roast properly	Oven controls improperly set.	<ul style="list-style-type: none"> • See the Using the oven section.
	Shelf position is incorrect or the shelf is not level.	<ul style="list-style-type: none"> • See the Using the oven section.
	Incorrect cookware or cookware of improper size being used.	<ul style="list-style-type: none"> • See the Using the oven section.
	Aluminum foil used improperly in the oven.	<ul style="list-style-type: none"> • See the Using the oven section.
	Oven bottom not securely seated in position.	<ul style="list-style-type: none"> • See the Care and cleaning of the range section.



	Oven thermostat needs adjustment.	<ul style="list-style-type: none"> • See the Adjust the oven thermostat—Do it yourself! section.
Oven will not self-clean	The oven temperature is too high to set a self-clean operation.	<ul style="list-style-type: none"> • Allow the oven to cool to room temperature and reset the controls.
	Oven controls improperly set.	<ul style="list-style-type: none"> • See the Using the self-cleaning oven section.
“Crackling” or “popping” sound	This is the sound of the metal heating and cooling during both the cooking and cleaning functions.	<ul style="list-style-type: none"> • This is normal.
Excessive smoking	Excessive soil.	<ul style="list-style-type: none"> • Press the CLEAR/OFF pad. Open the windows to rid the room of smoke. Wait until the LOCKED DOOR light goes off. Wipe up the excess soil and reset the clean cycle.
Oven door will not open after a clean cycle	Oven too hot.	<ul style="list-style-type: none"> • Allow the oven to cool below locking temperature.
Oven not clean after a clean cycle	Oven controls not properly set	<ul style="list-style-type: none"> • See the Using the self-cleaning oven section.
	Oven was heavily soiled.	<ul style="list-style-type: none"> • Clean up heavy spillovers before starting the clean cycle. Heavily soiled ovens may need to self-clean again or for a longer period of time.
“LOCK DOOR” flashes in the display	The self-clean cycle has been selected but the door is not closed.	<ul style="list-style-type: none"> • Close the oven door.
LOCKEDDOOR light is on when you want to cook	The oven door is locked because the temperature inside the oven has not dropped below the locking temperature.	<ul style="list-style-type: none"> • Press the CLEAR/OFF pad. Allow the oven to cool



“F— and a number or letter” flash in the display	You have a function error code.	<ul style="list-style-type: none"> • Press the CLEAR/OFF pad. Allow the oven to cool for 30 seconds for “F— and a number or letter” flash in the display to stop.
	If the function code repeats.	<ul style="list-style-type: none"> • Disconnect all power to the range for at least 30 seconds and then reconnect power. If the function error code repeats, call for service.
Display flashes	Power failure.	<ul style="list-style-type: none"> • Reset the clock.
Unable to get the display to show “SF”	Oven control pads were not pressed properly.	<ul style="list-style-type: none"> • The BAKE and BROIL HI/LO pads must be pressed at the same time and held for 3 seconds.
Power outage, clock flashes	Power outage or surge.	<ul style="list-style-type: none"> • Reset the clock. If the oven was in use when the power outage occurred, you must reset it by pressing the CLEAR/OFF pad, setting the clock and resetting any cooking function.
“Burning” or “oily” odor emitting from the vent	This is normal in a new oven and will disappear in time.	<ul style="list-style-type: none"> • To speed the process, set a self-clean cycle for a minimum of 3 hours. See the Using the self-cleaning oven section.
Strong odor	An odor from the insulation around the inside of the oven is normal for the first few times the oven is used.	<ul style="list-style-type: none"> • This is temporary.
	Improper air/gas ratio in the oven.	<ul style="list-style-type: none"> • Call for service.
Fan noise	A cooling fan may automatically turn on and off to cool internal parts.	<ul style="list-style-type: none"> • This is normal. The cooling fan will turn off and on.

Warning

This content is compiled from multiple sources and is provided for reference purposes only. It may not be complete or fully applicable to all situations. If you are unable to resolve your issue, please contact the product manufacturer or an authorized service provider for official support.

