

## Guide to the dishwasher

### Appliance overview

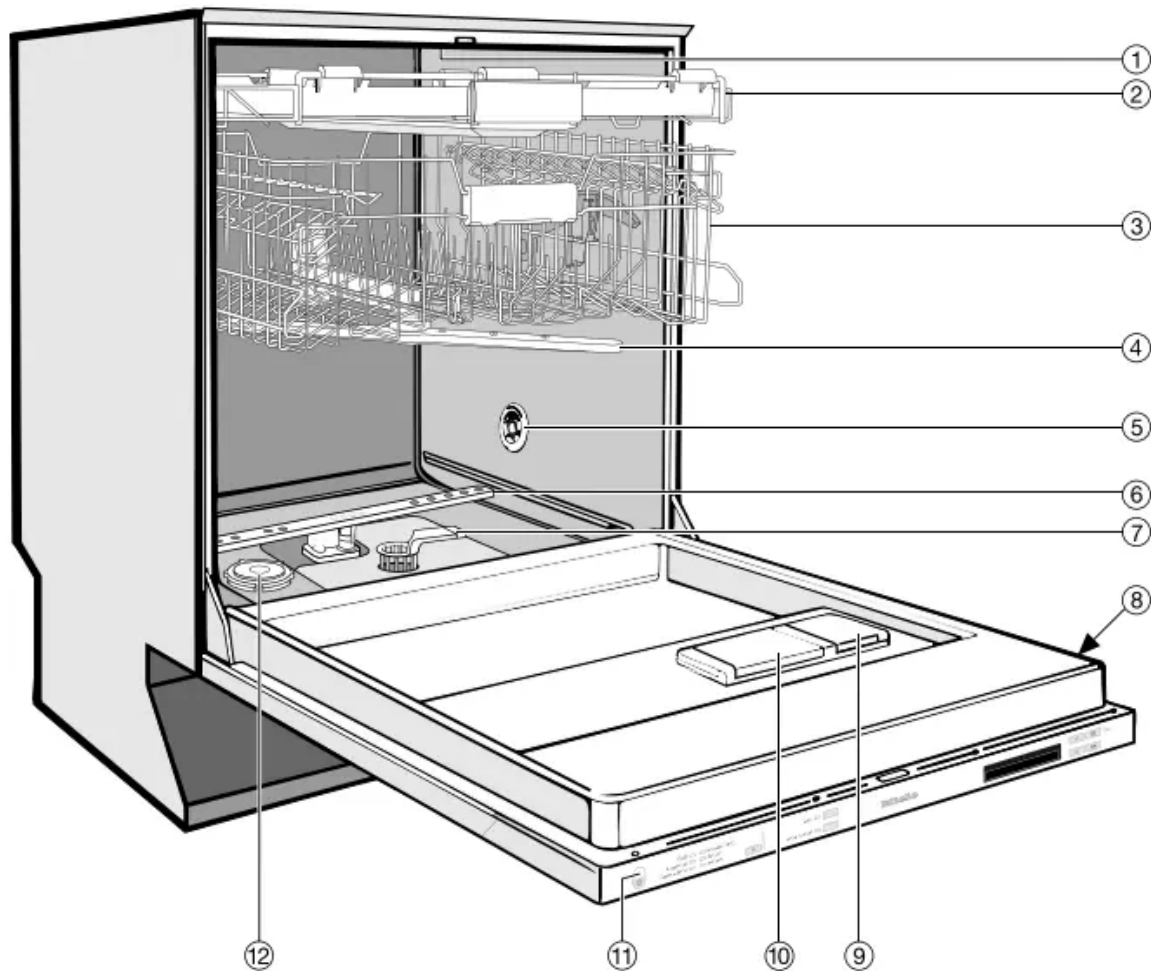

- 1 Upper spray arm (not visible)
- 2 Cutlery tray (depending on model)
- 3 Upper basket
- 4 Middle spray arm
- 5 Heat exchanger return (depending on model)
- 6 Lower spray arm
- 7 Filter combination
- 8 Data plate
- 9 Rinse aid reservoir
- 10 Double-chamber detergent dispenser

11 In-operation indicator light

12 Reservoir for reactivation salt

## Control panel

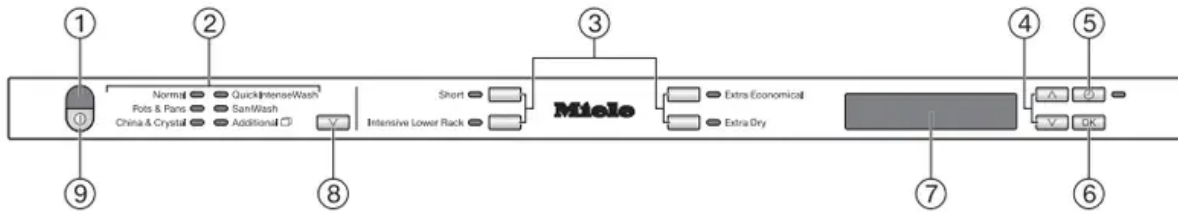

1 In-operation indicator light

2 Program selection

3 Option buttons with indicator lights d

4 Arrow buttons  $\nabla \wedge$

5  button (FlexiTimer) with indicator light

6 OK button

7 Display

8 Program selection button  $\nabla$

9  (On/Off) button

These operating instructions apply to several different dishwasher models with different heights.

The specific dishwasher models are referred to as follows:

Standard = 31 11/16" (80.5 cm) high dishwashers (integrated) and 33 1/4" (84.5 cm) high dishwashers (freestanding) XXL = 33 1/4" (84.5 cm) high dishwashers (integrated)

## Display functions

### General information

The display is used to select or set the following:

- The program
- The FlexiTimer (Delay Start)
- The Settings menu

The display can show the following:

- The program stage

- The estimated time left for the program to run
- Any relevant fault messages and information

To save energy, the dishwasher switches off after a few minutes if you do not press any buttons during this time.

To switch the dishwasher back on again, press the ⓘ button.

### Settings menu



The Settings menu is used to adapt the electronic module of the dishwasher to changing requirements. See the “Settings menu” chapter for more information on accessing the settings menu.

The arrows in the display indicate additional options. You can use the ▲▼ arrow buttons next to the display, as appropriate, to select these additional options.

The OK button is used to confirm a message or setting and also to move to the next menu or another level.

The option which is selected will have a check ✓ next to it.

To exit a sub-menu, use the ▲▼ arrow buttons to select the Back ↶ option in the display and confirm your choice with OK.

If you do not press any of the buttons for several seconds, the display will return to the previous level. You may need to enter your settings again.

## Caring for the environment

### Disposal of the packing material

The cardboard box and packing materials protect the appliance during shipping. They have been designed to be biodegradable and recyclable.

Ensure that any plastic wrappings, bags, etc. are disposed of safely and kept out of the reach of children. Danger of suffocation!

### Disposal of your old appliance

Electrical and electronic appliances contain valuable materials. They also contain certain substances, compounds and components which were essential for the proper functioning and safe

use of the equipment. Handling these materials improperly by disposing of them in your household waste can be harmful to your health and the environment. Therefore, please do not dispose of your old appliance with regular household waste and follow local regulations on proper disposal.

Consult with local authorities, dealers or Miele in order to dispose of and recycle electrical and electronic appliances. Miele assumes no responsibility for deleting any personal data left on the appliance being disposed. Please ensure that your old appliance is kept away from children until removal. Observe safety requirements for appliances that may tip over or pose an entrapment hazard.

## **Energy-saving dishwashing**

This dishwasher is economical in the consumption of water and energy. For best results follow these tips:

- For most economical dishwashing, make full use of the baskets without overloading the dishwasher.
- Choose a program that best suits the degree of soiling and the type of dishes being washed.
- Select the Normal program (depending on model) for energy-saving dishwashing. This program is the most efficient in terms of its combined energy and water consumption at cleaning normally soiled dishes.
- If your dishwasher is connected to a hot water supply, select the Energy Saver program for washing a lightly to moderately soiled load. Because the water is not heated in this program, dishes may still be slightly damper at the end of this program than it would be with other programs.
- Follow the detergent manufacturer's recommendations on detergent dosage.
- When using powder or liquid detergent, you can use 1 / 3 less detergent if baskets are only half full.

## **Before using for the first time**

### **Opening the door**

At the end of programs with a drying phase (see “Program overview”), the door will open automatically a little in order to help the drying process. This function can be deactivated if preferred (see “Settings menu - AutoOpen”).

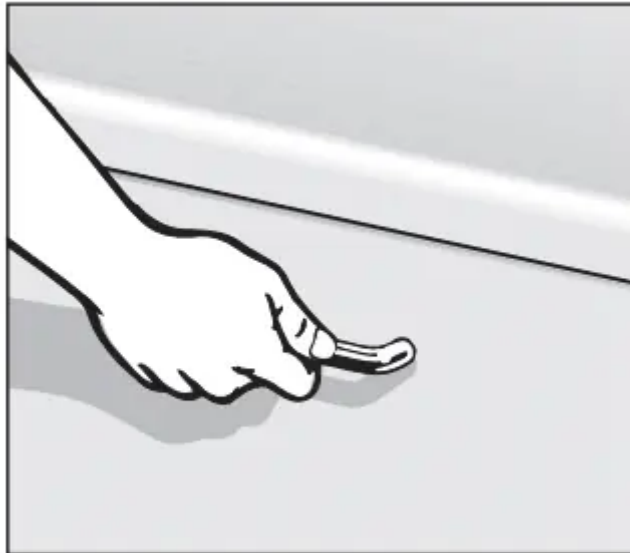

- Pull the handle to open the door.
- Open the door fully so that the door catch rail retracts again.

If the door is opened during operation, all functions are automatically interrupted.

 Water in the dishwasher may be hot. Danger of scalding! Only open the door during operation if absolutely necessary and exercise extreme caution when doing so.

 Keep the area around the door free of obstructions.

## Closing the door

- Push the baskets in.
- Then lift the door upwards and push until it clicks into position.

 Danger of crushing injuries! Do not put your hand inside the door as it is closing.



## Basic settings

- Open the door.
- Turn the dishwasher on with the  button.

The welcome screen will appear when the dishwasher is turned on for the first time.

## Language

The display will change automatically to the screen for setting the language.

- Use the   arrow buttons to select the language you want and also the country, if appropriate, and confirm your selection with OK.



For more information about the function of the display, see “Display”.



A check ✓ will appear next to the language that has been set.

### Time of day

The display will then change to the screen for setting the time.

The current time of day must be set before you can use the “FlexiTimer” programming option.

- Use the   arrow buttons to set the hour and confirm with OK.
- Then set the minutes and confirm with OK.

Keeping the   arrow buttons pressed will increase or decrease the time automatically.

### Water hardness

The display changes to the screen for setting the water hardness.



- The dishwasher must be programmed to the correct water hardness for your area.
- Your local water authority will be able to advise you of the water hardness level in your area.
- Where the water hardness fluctuates e.g. between 10 - 16 gr/gal (10 - 15 °d), always program the dishwasher to the higher value (16 gr/gal or 15 °d in this example).

It is useful to know your water hardness so that you can provide the service technician with this information in the event of any service calls.

Enter the water hardness below:

\_\_\_\_\_ gr/gal (°d)

The dishwasher is programmed at the factory for a water hardness level of 1 gr/gal (1 °d).

- Use the   arrow buttons to select the hardness of your water supply and confirm with OK.

See “Settings menu, Water hardness” for more information.

The message Set-up successfully completed will then appear in the display.

After confirming this with OK, the prompts  Refill salt and  Refill rinse aid may appear.

- Add salt and rinse aid if necessary (see “Before using for the first time, Dishwasher salt” and “Rinse aid”).
- Confirm the messages with OK.

The program selected will appear briefly in the display and the appropriate indicator light will come on.

Then, the display will show the estimated program duration for the program selected.

These basic settings will be saved after the dishwasher has been through one complete program.

### **Before using the appliance for the first time, you require:**

- Approx. 2 qt (2 l) of water
- Approx. 2 kg (4 lbs) of dishwasher salt
- Domestic dishwasher detergent
- Rinse aid formulated for domestic dishwashers

Every dishwasher is tested at the factory. There will be residual water in the appliance from this test. It is not an indication that it has been used previously.

### **Dishwasher salt**

In order to achieve good cleaning results, the dishwasher needs to operate with soft water. Hard water results in a build-up of calcium deposits on dishes and in the dishwasher.

Water supplies with a hardness level higher than 4 gr/gal (4 °d) needs to be softened. This takes place automatically in the integrated softener assembly. The softener assembly in the dishwasher is suitable for a water hardness level of up to 73 gr/gal (70 °d).

The softener assembly requires dishwasher salt.

Depending on the water hardness level (< 22 gr/gal or 21 °d), dishwasher salt is not required if combination tablets are being used (see “Operation - Detergent”).

If the water in your area is very soft and consistently lower than 5 gr/gal (5 °d - German scale) you do not have to add dishwasher salt. The prompt to add salt will be switched off automatically if the softener assembly has been programmed for this to happen.



Dishwasher detergent will damage the softener assembly. Do not fill the salt container with dishwasher detergent (even liquid detergent).



Use only special, coarse-grained dishwasher salt or other pure kitchen salt. Other types of salt may contain insoluble components which can damage the softener assembly.

### **Filling the salt reservoir**

Important! Before filling the salt reservoir with dishwasher salt for the first time, you must fill it with approx. 2 qt (2 l) of water to enable the salt to dissolve.

Once the dishwasher has been used for the first time, there is always sufficient water in the reservoir.

- Remove the lower basket from the wash cabinet and unscrew the salt reservoir cap.

Water will run out of the reservoir when the cap is removed. It should therefore only be removed in order to refill the salt reservoir.

- Fill the reservoir with approx. 2 qt (2 l) of water (first use only).

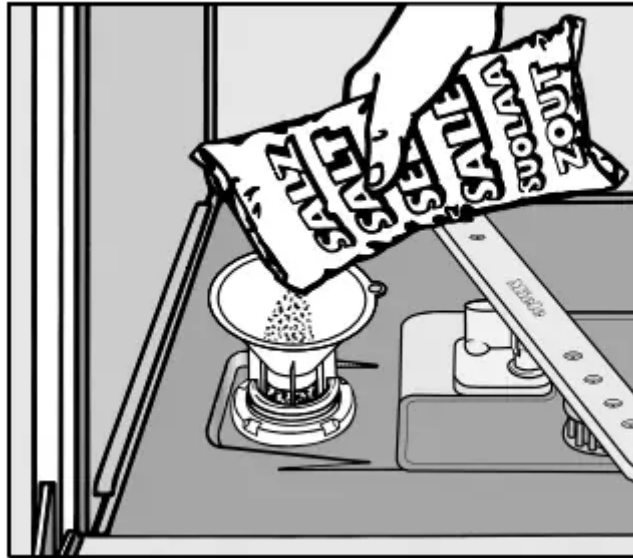

- Place the funnel provided over the salt reservoir and carefully fill with salt until the reservoir is full. The salt reservoir holds approx. 4 lbs (2 kg) of salt depending on the brand used.
- Clean any excess salt from around the reservoir opening and then screw the cap on again firmly.
- Immediately after filling the salt reservoir, run the QuickIntenseWash program with the Short programming option selected and without any dishes in the dishwasher to remove any traces of salt from the wash cabinet.

### Salt refill indicator

- Fill the salt reservoir with dishwasher salt for reactivation when  Refill salt appears in the display. If it appears during a program, wait until the end of the program.
- Confirm with OK.

The salt refill indicator will go out.



Risk of corrosion!

Immediately after filling the salt reservoir, run the QuickIntenseWash program with the Short programming option selected and without any dishware in the dishwasher to remove any traces of salt from the wash cabinet.

After the salt reservoir has been filled, the refill indicator may still appear in the display if the salt concentration has not yet reached the correct level. If this is the case, confirm again with OK.

The salt refill indicator will be turned off if you have programmed the dishwasher for a water hardness below 5 gr/gal (5 °d).

If you only ever use Tab products in your dishwasher, you can switch off both refill indicators for salt and rinse aid if you wish (see “Settings menu, Switching off the refill indicators”).

If you switch to using detergent that does not contain salt or rinse aid, it is important to remember to add dishwasher salt and rinse aid and to switch the indicators back on.

## Rinse aid

Rinse aid is needed to prevent spotting on dishes and glassware. The rinse aid is filled in the reservoir and the set amount will be automatically dosed.

 Filling the rinse aid reservoir with detergent will damage the reservoir. Only pour rinse aid formulated for residential dishwashers into the reservoir.

When using “Tab” detergents rinse aid is not needed.

## Adding rinse aid

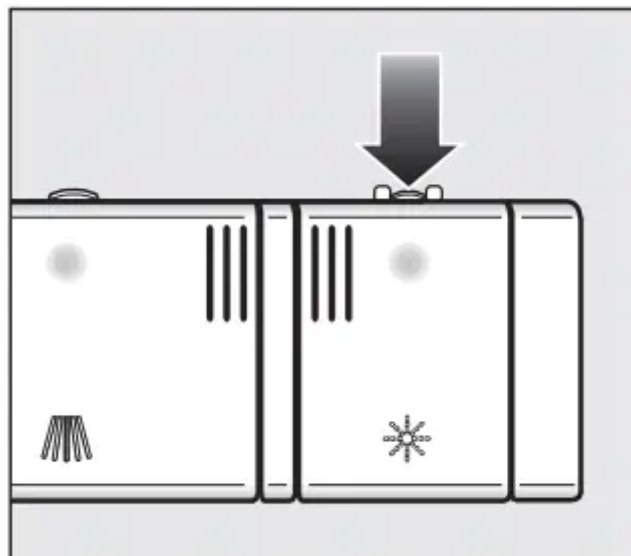

- Press the button on the lid of the rinse aid reservoir in the direction of the arrow until the flap springs open.

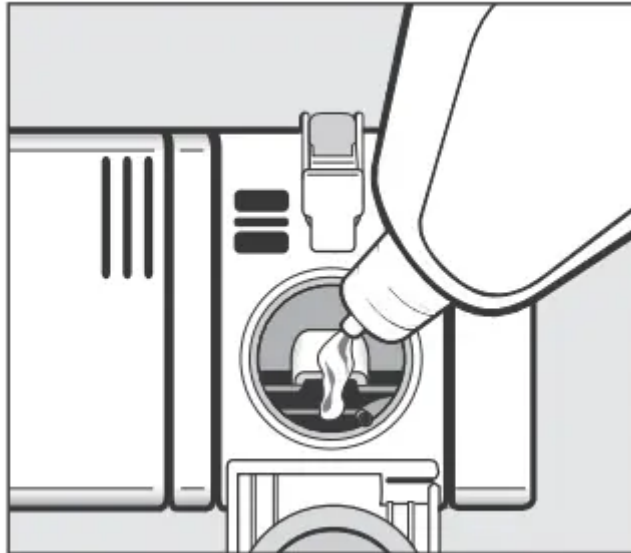

- Add rinse aid only until it is visible in the opening.

The rinse aid reservoir holds approx. 3.7 oz. (110 ml).

- Close the flap firmly so that it clicks into place. Otherwise water can enter the rinse aid reservoir during a program.
- Wipe up any spilled rinse aid. This prevents over-foaming occurring during the next program.

You can adjust the rinse aid dosage for best results (see “Settings menu Rinse aid”).

### **Rinse aid indicator**

When the  Refill rinse aid message appears in the display, the reservoir contains sufficient rinse aid for 2 - 3 programs only.

- Add rinse aid.
- Confirm with OK.

The rinse aid refill indicator will go out.

If you only ever use Tab products in your dishwasher, you can turn off both refill indicators for salt and rinse aid if you wish (see “Settings menu - Turning off the refill indicators”).

## **Loading the dishwasher**

### **Tips**

Remove coarse food residues from the dishes.

There is no need to rinse items under running water!



Do not wash items soiled with ash, sand, wax, grease, or paint in the dishwasher. These will damage the dishwasher.

Dishes can be loaded anywhere in the baskets, but the following notes should be observed:

- Do not place dishes or cutlery inside other pieces. They will cover each other.
- Load the dishes so that water can access all surfaces. This ensures that they get properly cleaned.
- Make sure that all items are securely positioned.
- Hollow items such as cups, glasses, pans, etc. must be inverted in the basket.
- Tall, narrow, hollow items, e.g., champagne glasses, should be placed in the center of the basket to ensure better water coverage.
- Concave items such as mugs or bowls should be placed at an angle so that the water can run off.
- The spray arms must not be blocked by items which are too tall or hang through the baskets. If in doubt, test for free movement by manually rotating the spray arms.
- Make sure that small items cannot fall through the holders in the baskets.

Small items, e.g., lids, should therefore be placed in the cutlery tray or cutlery basket (depending on model).

Some foods may contain natural dyes, e.g., carrots, tomatoes or tomato sauce. Plastic items in the dishwasher may discolor if large quantities of these foodstuffs find their way into the dishwasher on the dishes. The stability of plastic items is not affected by this discoloration. Cleaning silver cutlery in the dishwasher may also cause plastic items to discolor.

Items not recommended for dishwashing

- Wooden cutlery, cutting boards and dishes or items with wooden parts
- Craft items, antiques, valuable vases, and decorative glassware
- Plastic items which are not heat-resistant: the high temperatures in the dishwasher may cause them to melt or lose shape.
- Copper, brass, tin and aluminum items may discolor or become matt.
- Colors painted over a glaze may fade after a number of washes.
- Delicate glassware and glassware containing lead crystal: clouding may occur over time.

**Please note:**

Silverware previously cleaned with a silver polish may still be damp or spotted at the end of a program, where water has not run off smoothly. It may need to be rubbed dry with a soft cloth.

Silver which has been in contact with foods containing sulphur can discolor. These include egg yolk, onions, mayonnaise, mustard, fish, and marinades.



Aluminum components (e.g., range hood grease filters) must not be cleaned with a commercial or industrial cleaning agent.

These may damage the material.

**Tip:** When purchasing new dishes and cutlery, make sure they are dishwashersafe.

### **Glass care**

- Clouding may occur on glasses after frequent washing. If delicate glassware is washed in the dishwasher, ensure that only very low temperatures are used (see program chart), or a special glass-care program is used (depending on model). This will reduce the risk of clouding.
- Purchase glassware which is dishwasher-safe (e.g., Riedel glassware).
- Use detergents with glass protective additives.

### **Loading examples**

#### **Loading for 10 standard place settings with cutlery tray**

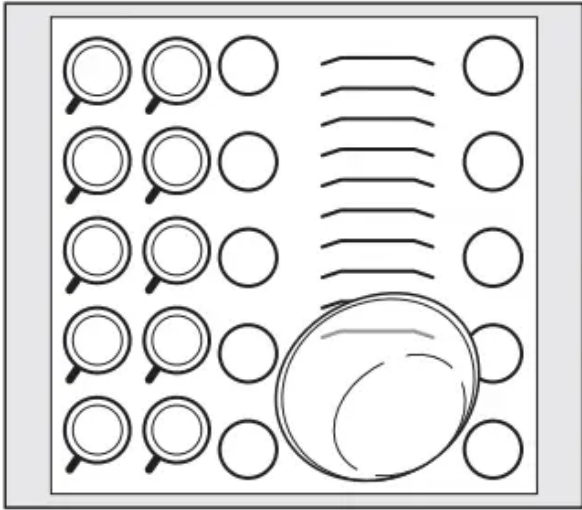

Upper basket

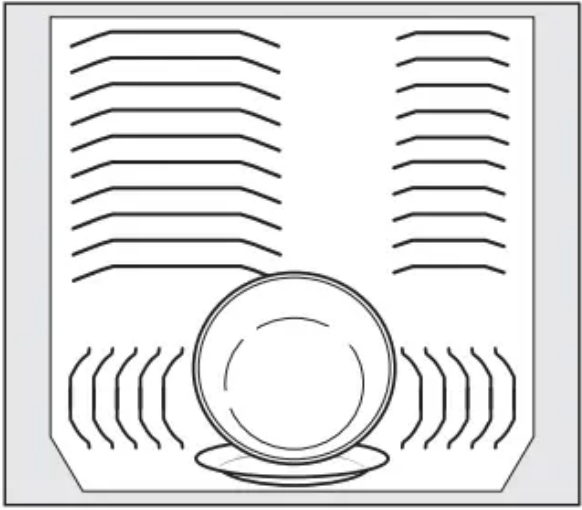

Lower basket

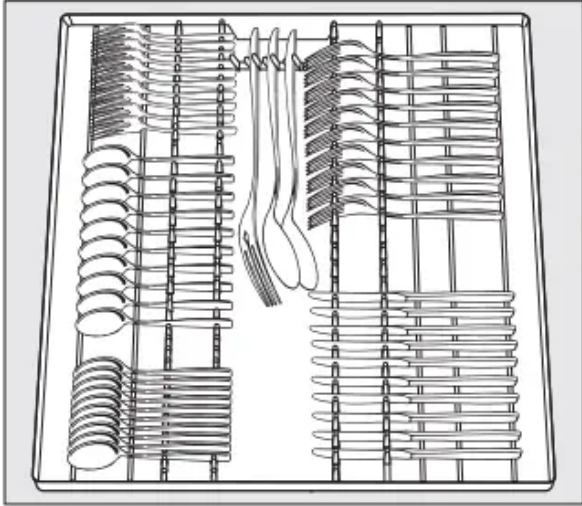

Cutlery tray (depending on model)

**Loading for 16 standard place settings with cutlery tray**



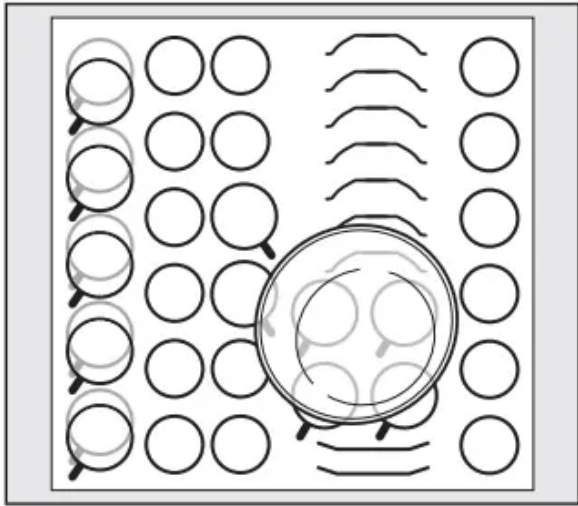

Upper basket

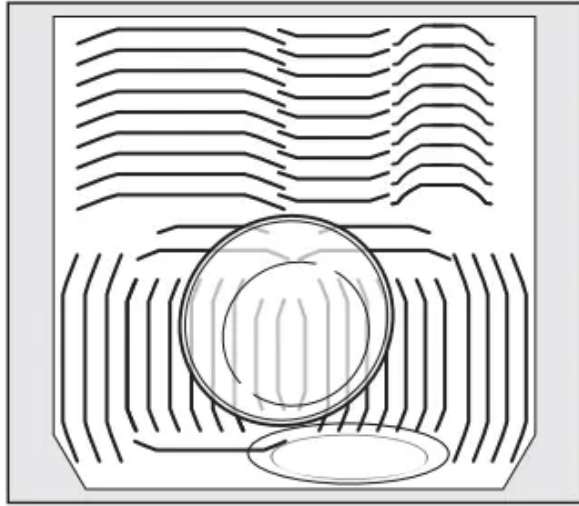

Lower basket

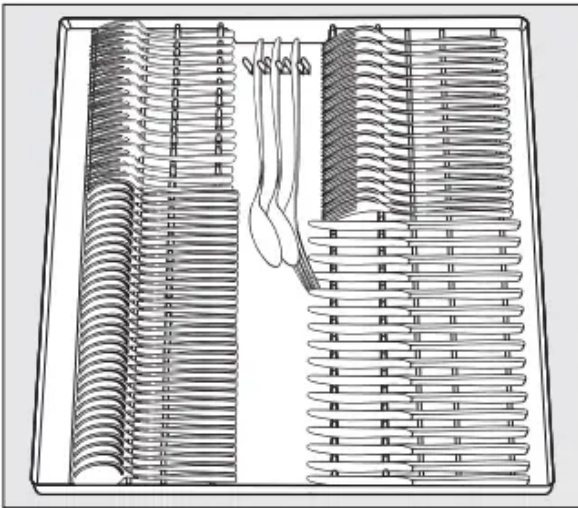

Cutlery tray (depending on model)

**Loading for 10 standard place settings with cutlery basket**

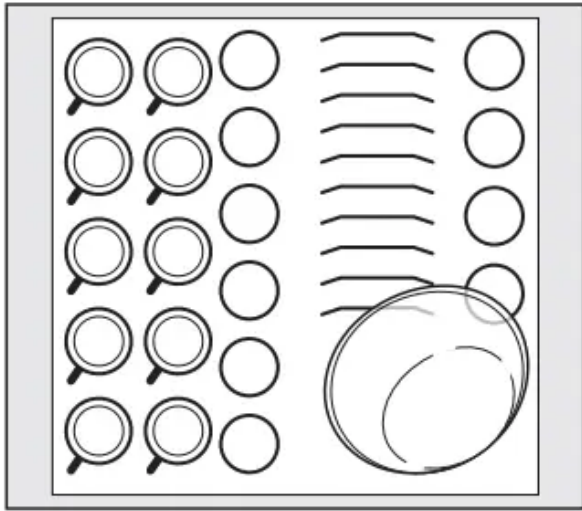

Upper basket

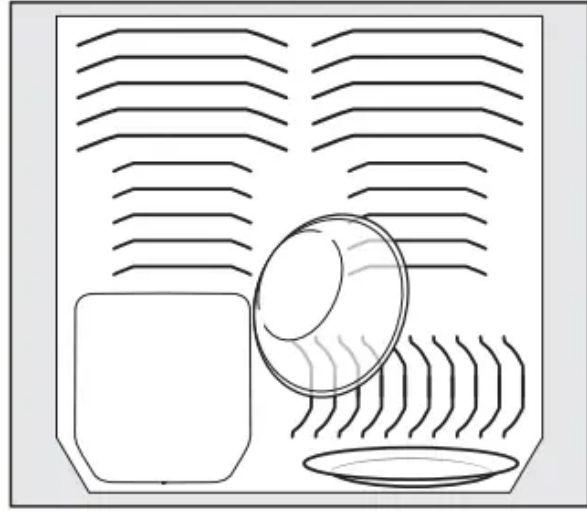

Lower basket

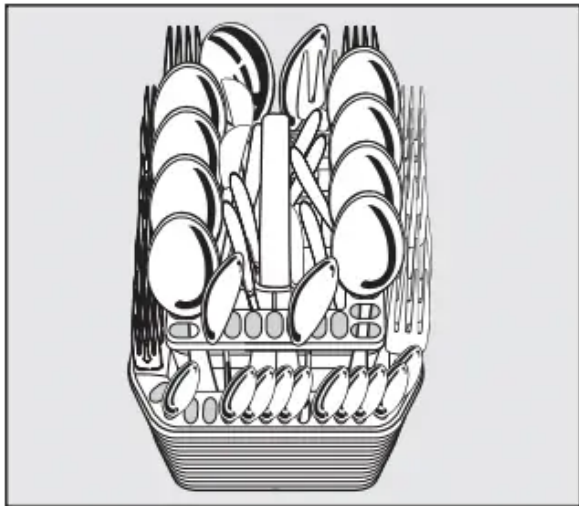

Cutlery basket

**Loading for 13 standard place settings with cutlery basket**

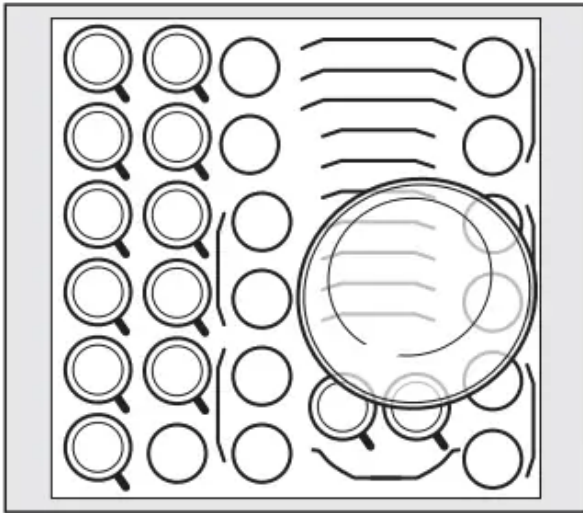

Upper basket



Lower basket

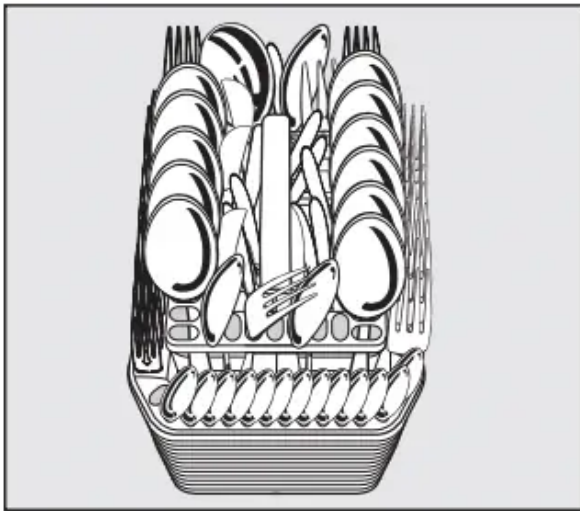

Cutlery basket

## FlexAssist

The yellow FlexAssist components indicate which elements of the baskets for dishes and cutlery tray are moveable. They also act as grips and have symbols embossed on them to show what the moveable parts are used for.

### Upper basket

 For safety reasons, do not operate the dishwasher without the upper and lower baskets in place (except when running the Tall items program, if available).

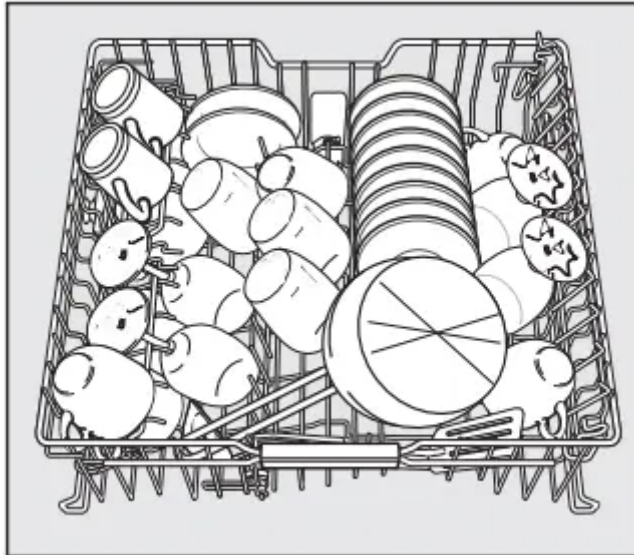

- Use the upper basket for small, lightweight and delicate items such as cups, saucers, glasses, dessert bowls, etc. Shallow pans or casserole dishes can also be placed in the upper basket.
- Long items such as soup ladles, mixing spoons, and long knives should be placed lying down across the front of the upper basket.

### Cup rack

- Using the yellow lever , lift the cup rack upwards to make room for tall items. Glasses can be arranged along the positioning rail of the cup rack to give them some support during the program.
- Lower the cup rack and lean the glasses against it or double stack smaller pieces.

### Hinged spikes

The rows of spikes can be lowered to make more room for larger items such as casserole dishes.

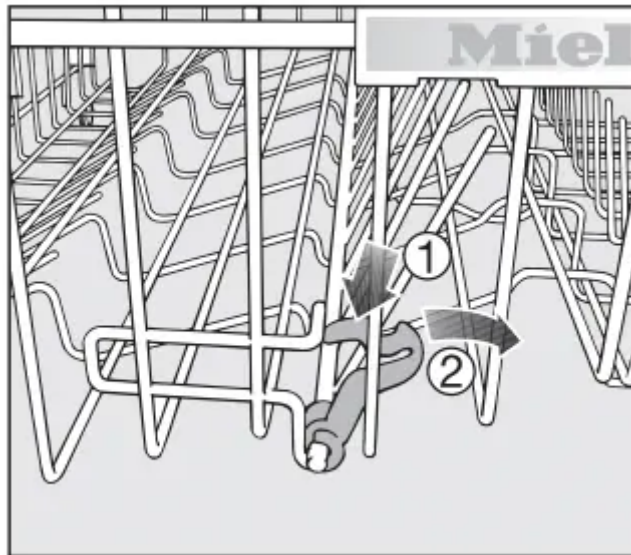

- Press the yellow lever downwards 1 and then lower the spikes 2.

### **XXL cup rack (depending on model)**

The cup rack can be set at two different widths so that it can also accommodate large cups.

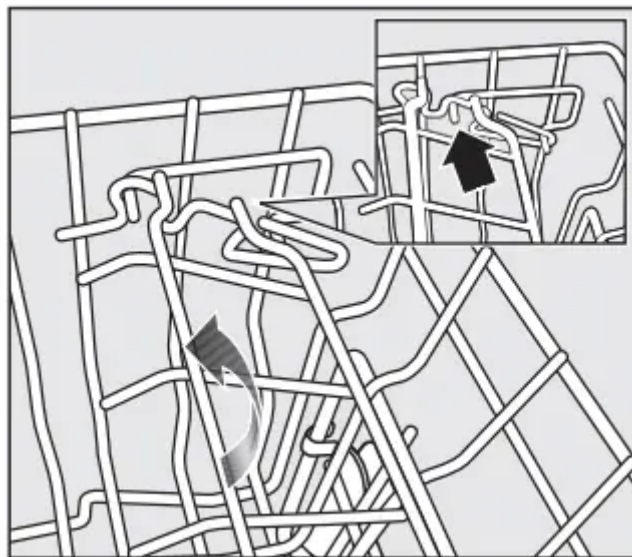

- Pull the cup rack upwards and click it back into position at the required width.

### **Glassware rail**

The glassware rail is designed to hold glasses with long stems securely.

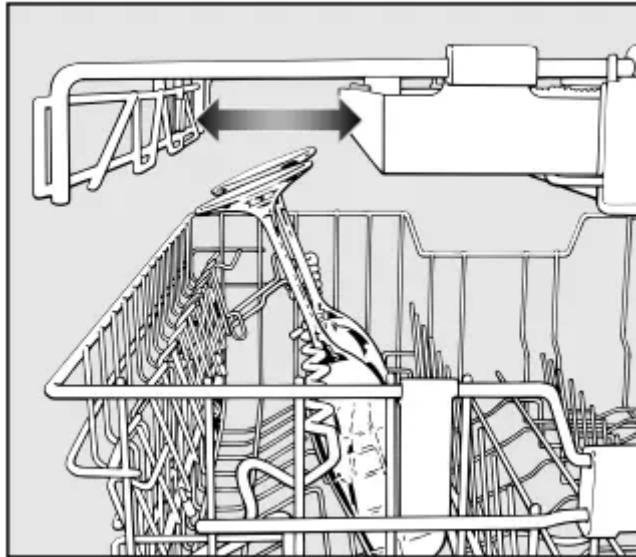

- Lower the glassware rail with the yellow lever  and lean tall glasses against it.
- You can also move one of the side inserts in the cutlery tray to make more room for tall glasses (see “Cutlery, 3D cutlery tray”).

### Adjusting the height

You can set the glassware rail at two different heights.

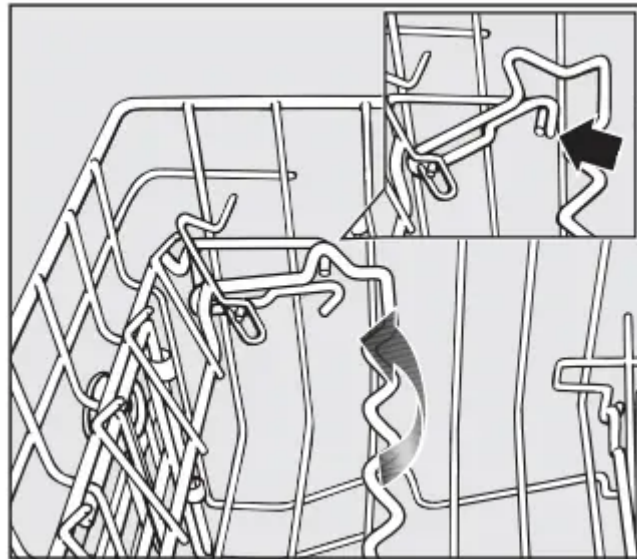

- Pull the rail upwards and click it back into position at the required height.

Use the lower position for small glasses and tumblers.

Use the higher position for tall glasses and glasses with stems.

### Adjusting the upper basket

In order to gain more space for taller

items the upper basket can be adjusted on three levels with 3/4" (2 cm) between each level.

The upper basket can also be set at an angle with one side high and the other side low. Make sure, however, that the basket can slide smoothly in and out of the cabinet.

- Pull the upper basket out.

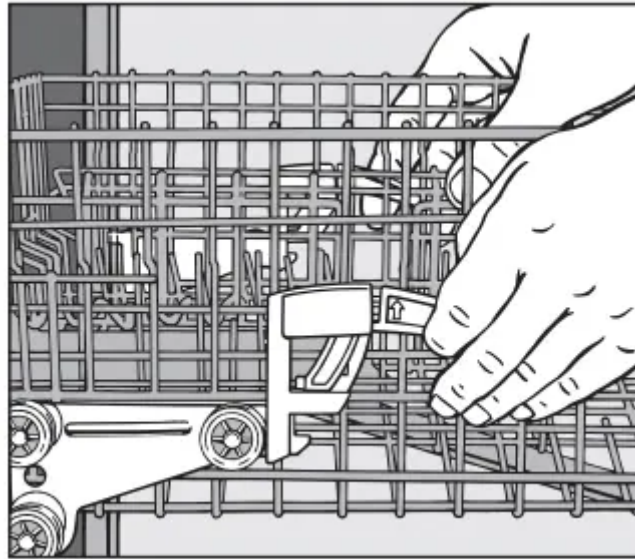

**To raise the upper basket:**

- Lift the basket until it clicks into place.

**To lower the upper basket:**

- Pull upwards on the levers at either side of the upper basket.
- Adjust the basket to the desired height and then push the levers securely back down into position.

Depending on the setting of the upper basket, the following plate dimensions can be accommodated.

**Dishwashers with cutlery basket** (see data plate for model number)

Upper basket adjustment	Plate Ø in inches (cm)		
	Upper basket		Lower basket
	ADA	Full-size	
Upper	7 7/8" (20)	9 7/16" (24)	12 3/16" (31) 13 3/4" (35*)
Middle	8 11/16" (22)	10 1/4" (26)	11 7/16" (29)
Lower	9 7/16" (24)	11" (28)	10 5/8" (27)

**Dishwashers with cutlery tray** (see data plate for model number)



Upper basket adjustment	Plate Ø in inches (cm)		
	Upper basket		Lower basket
	ADA	Full-size	
Upper	7 7/8" (15)	7 1/2" (19)	12 3/16" (31) 13 3/4" (35*)
Middle	6 11/16" (17)	8 1/4" (21)	11 7/16" (29)
Lower	7 1/2" (19)	9 1/16" (23)	10 5/8" (27)

\* When tilted, plates of up to 13 3/4" (35 cm) can be accommodated (see "Lower basket").

Depending on the setting of the upper basket, a variety of plate dimensions can be accommodated.

### Lower basket

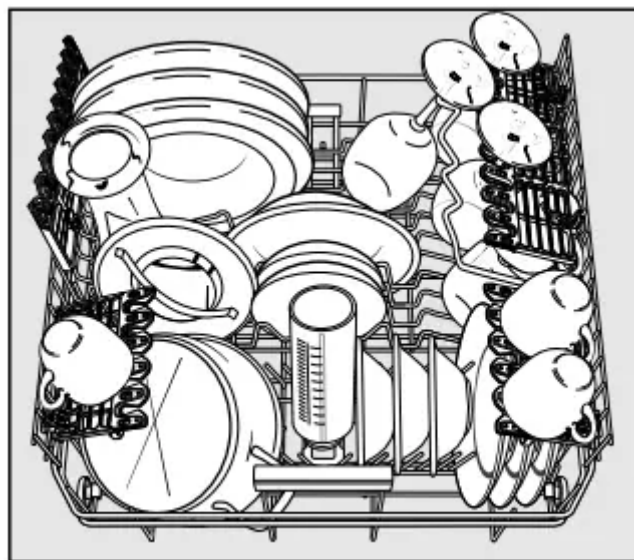

- For larger and heavier items such as plates, serving platters, saucepans, bowls, etc.

Glasses, cups and small items such as saucers can also be placed in the lower basket. Do not place thin, delicate glassware in the lower basket.

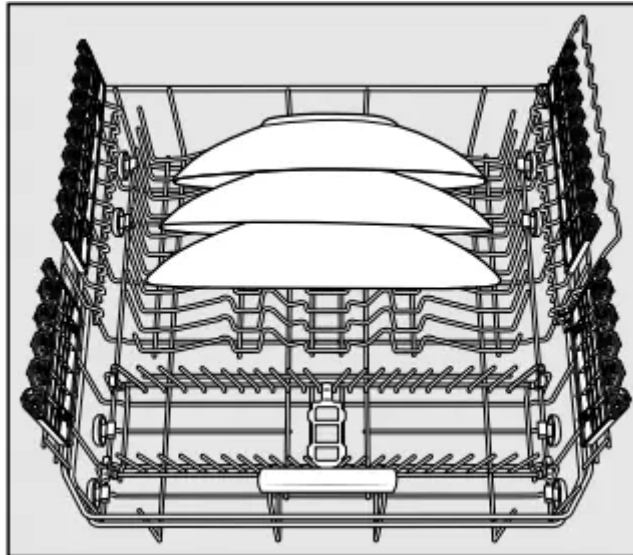

- Place large platters and dishes in the center of the lower basket.

When tilted, plates up to 13 3/4" (35 cm) in diameter can be accommodated.

### Removable MultiComfort insert

The rear section of the lower basket is used for washing cups, glasses, plates, pots and pans.

You can remove the MultiComfort insert to make more room for larger items such as casserole dishes.

### Removing the insert

- Pull the yellow handle forwards and remove the insert.

### Refitting

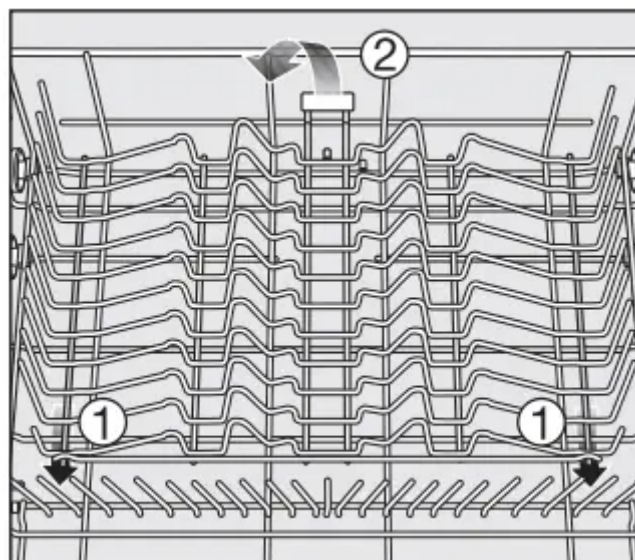

- Fit the insert into the lower basket with the hooks under the long crosspiece 1.
- Press down on the insert until it clicks into position 2.

### FlexCare glass holder

Silicone padding in the FlexCare glass holder provides a stable and secure hold for delicate stemware.

- Stem glassware, e.g. wine glasses or champagne flutes, can be leaned against the glass rack or suspended from it.
- The glass holder can be raised to make more room for tall items.

You can set the glass holder at two different heights.

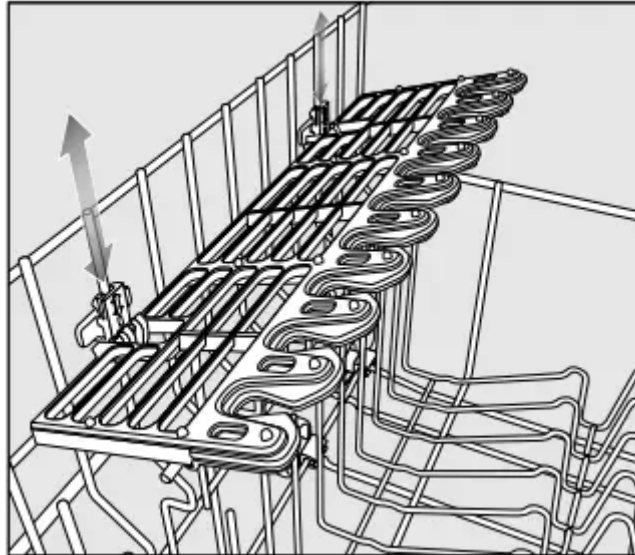

- Slide the glass holder to the desired height until the catches click into place at the top or bottom.

### Glassware rail

The glassware rail is designed to hold glasses with long stems securely.

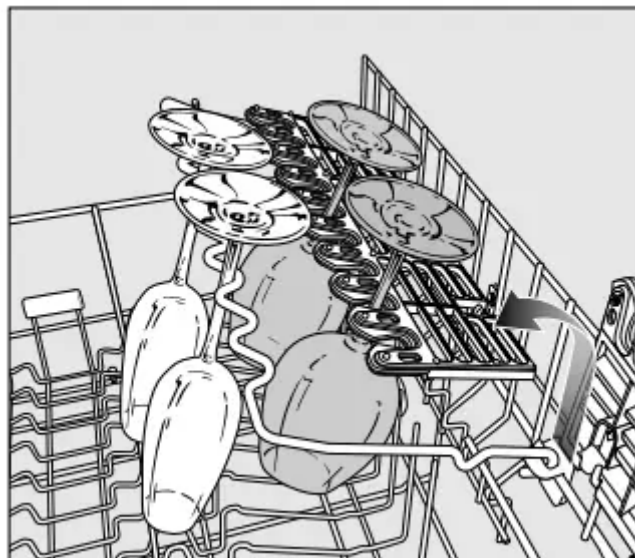

- Lower the rail and lean tall glasses against it.

### Hinged spikes

The spikes at the front are used for washing plates, soup bowls, platters, dessert bowls, and saucers.

The spikes can be lowered to make more room for large items, e.g. pots, pans and dishes.

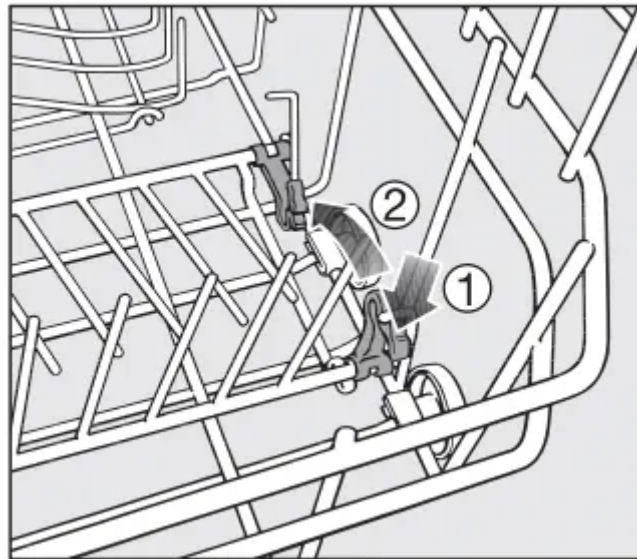

- Press the yellow lever downwards 1, and then lower the spikes 2.

### Bottle holder

The bottle holder can be used to wash narrow items, e.g., milk and baby bottles.

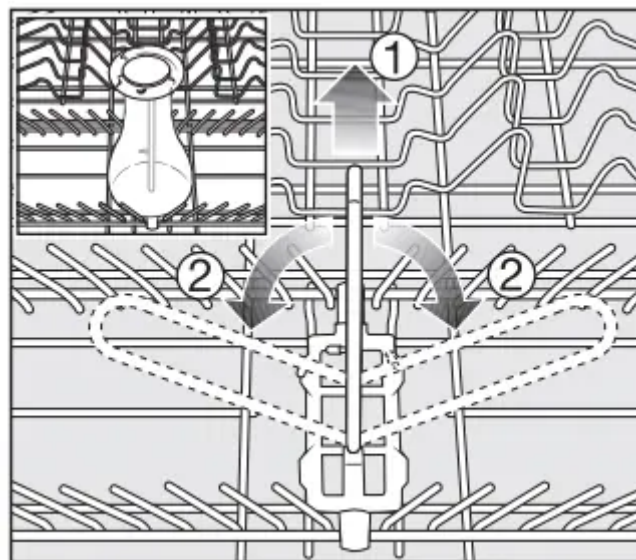

- If the bottle holder is not needed, lift it up 1 and fold the sides down 2, as illustrated.

### Pot rests and filters

You can also wash Miele pot rests and Miele hood filters.

- Select the Grates & Filters program for optimum dishwashing results.

---

 Protruding parts can damage the dishwasher. Load the dishwasher in such a way that no corners protrude over the side of the basket.

---

 Heavy and sharp wash loads can damage the coating of the basket struts. Load pot rests and filters carefully.

### Pot rests

---

 Rust damages the dishwasher. Wash only pot rests that are undamaged and not rusty.

- Place the upper basket in the top position.
- Load the pot rest in the lower basket. To do so, remove the MultiComfort insert and fold over the front row of spikes.
- Place the pot rest on the bottom of the basket and against the struts on one side. On the other side of the basket, flip up the glass holder and place this side of the pot rest on the silicone padding of the glass holder.

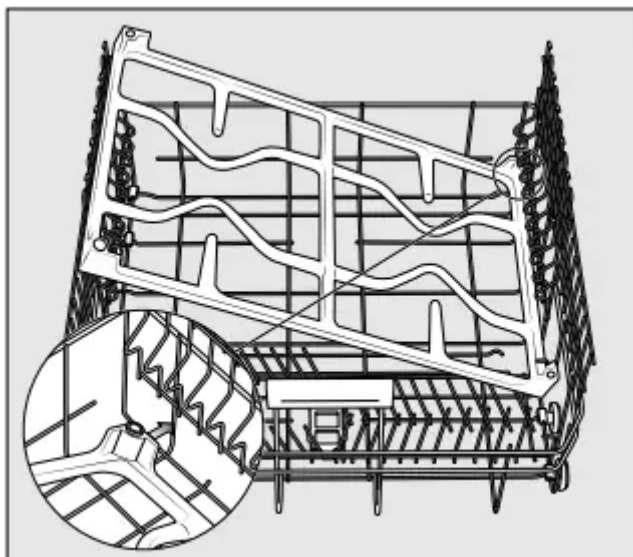

### Filters

You can wash two range hood filters in the upper basket and two in the lower basket at once.

If you only want to wash two filters, put them in the top basket.

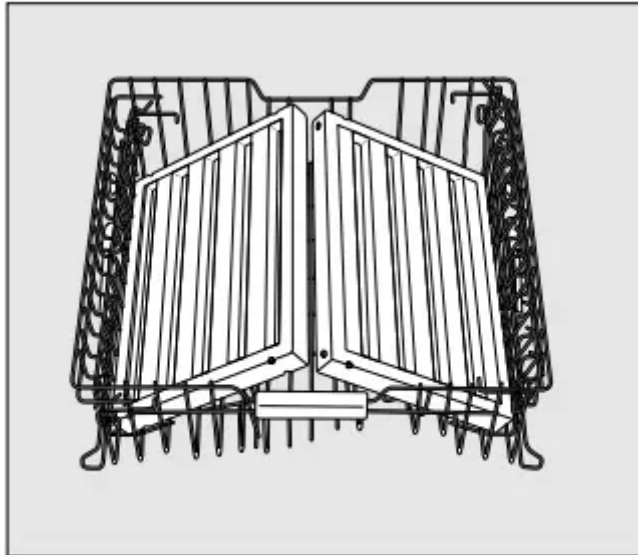

Upper basket

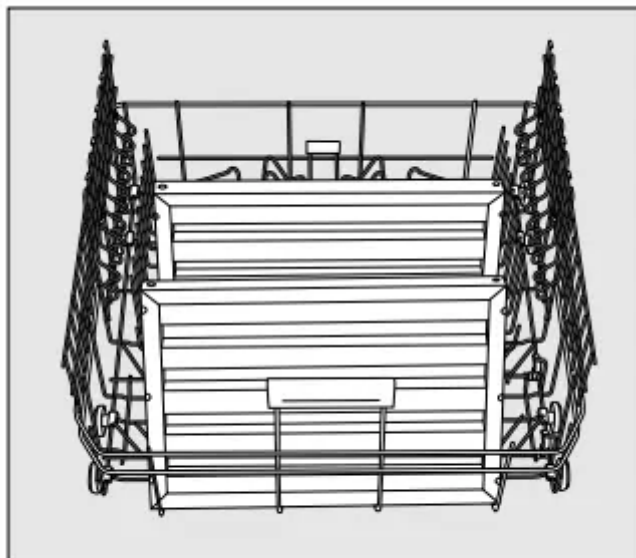

Lower basket



Be careful when unloading the filters. At the end of the program, the filters may still contain hot water.

## Operation

### Detergent



Only use detergents formulated for domestic dishwashers.

### Active ingredients

Modern detergents contain various active ingredients, the most important of which are:

- Complexing agents to prevent calcification.

- Alkalis to aid the removal of dried-on soiling.
- Enzymes to break down starch and loosen protein.
- Oxygen-based bleaching agents to remove colored stains (e.g., tea, coffee, tomato sauce).

Most dishwasher detergents are mildly alkaline and contain enzymes and oxygen-based bleaching agents.

There are different types of detergent:

- Powder and liquid gel detergents. These detergents allow you to adjust the amount dispensed according to the amount of load and level of soiling.
- Tab detergents. These are suitable for most levels of soiling.

You can also buy Tab products (see “Options, DetergentAgent”, if applicable).

In addition to detergent, these products contain rinse aid and salt substitutes. They are available as “3 in 1” or when they also contain other components such as glass and stainless steel protective additives and enhanced cleaning power, as “5 in 1”, “7 in 1”, “All in 1” etc.

Refer to the manufacturer’s packaging as to whether Tab products are suitable for the water hardness level in your area.

Please note that the cleaning and drying results of Tab detergents can vary greatly.

For optimum cleaning and drying results, use Miele dishwasher detergent and add Miele salt and Miele rinse aid separately.

## Detergent dosage

- Follow the dosage recommended by the manufacturer on the packaging.
- Unless directed otherwise, use one detergent tab or add 1 1/4 - 2 tablespoons (20 - 30 ml) detergent to compartment II, depending on the level of soiling. With very heavy soiling you can also add a small amount of detergent to compartment I.
- Tabs may not dissolve completely when the “QuickIntenseWash” program (if available) is used.

Use only the recommended amount of detergent. Continued use of too much detergent may cause machine damage.



Dishwasher detergents can cause burning in the nose, mouth, and throat if swallowed, or inhibit breathing.

Avoid inhaling or swallowing dishwasher detergent. Keep children away from detergent. Keep detergent out of the reach of children. Keep children away from the dishwasher when the door is open. There could still be detergent residues in the dishwasher. Only add detergent just before starting the program and lock the door with the child lock (depending on model).

## Adding detergent

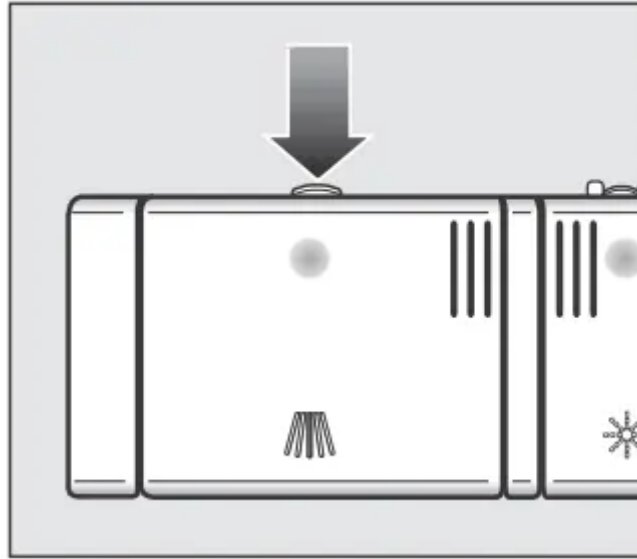

- Press the opening catch on the detergent dispenser. The flap will spring open.

The flap is always open at the end of a program.

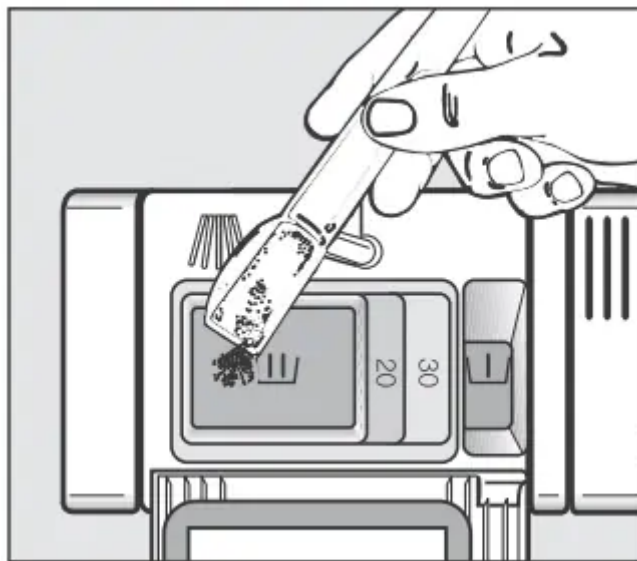

- Add the required amount of detergent and close the flap.
- Make sure that the detergent packaging is properly closed after use to avoid it getting damp and becoming lumpy.

## Dispensing aid

Compartment I holds a maximum of 2 teaspoons (10 ml), Compartment II holds a maximum of 3 ½ tablespoons (50 ml) of detergent.

The marks in compartment II indicate the levels of approximately 1 ¼ and 2 tablespoons (20 and 30 ml) respectively. The marks indicate the approximate fill level in ml when the door is open in a horizontal position.

## Turning on

- Turn on the water supply if it is turned off.
- Open the door.
- Make sure the spray arms are not obstructed.
- Press the  button for at least 2 seconds.

The program selected will appear briefly in the display and the appropriate indicator light will come on.

Then, the display will show the estimated program duration for the program selected.

## Selecting a program

Choose your program according to the type of load and the degree of soiling.

The different programs and their uses are described in the Program Overview chapter.

- Use the program selection button  to select the program required.

The indicator light of the selected program will come on.

Additional programs can be selected using the Additional  option.

- Use the program selection button  to select the Additional  option.

The first of the additional programs will appear in the display.

- Use the  arrow buttons to select the program required.

During the course of the program, you can use OK to display the name of the program which is currently running.

You can now select program options (see “Options”).

If any program options are selected, the appropriate indicator lights will also light up.

## Starting a program

- Start the program by closing the door within four seconds of the last press of a button.

The program will begin.

The Optical Interface comes on to show that a program has been started.

If you do not close the door within four seconds, the indicator light of the selected program will flash and the message Press OK to start will appear in the display.

The program cannot be started until you press the OK button and close the door within four seconds.

A program should only be canceled in the first few minutes, if at all. Otherwise important program stages could be omitted.

## Time display

The estimated duration of the program selected appears in hours and minutes in the display before the program begins. During the program, the time left until the end of the program can only be viewed with the door open.

Each program phase is indicated by a symbol:

-  Pre-wash / Soak
-  Wash
-  Interim rinse
-  Rinse cycle
-  Drying
-  Finish

The program duration displayed may vary with the same program. It is influenced by, among other things, the water temperature at each intake, the reactivation process, the softener assembly, the type of detergent, the amount of dishes, and the amount of soiling.

When a program is selected for the first time, the display will show the average program duration for a cold water intake.

The times shown in the program overview refer to standard test loads and temperatures.

Each time a program is run, the electronic module calculates the program duration required depending on the temperature of the water taken into the dishwasher and the amount of dishes.

## Energy management

To save energy, the dishwasher will switch off automatically 10 minutes after the last time a button has been pressed or after the end of the program (see “Settings menu - Optimize standby”).

- Press the  button to switch the dishwasher back on.

The dishwasher will not switch off while a program or the FlexiTimer is running or if there is a fault.

## At the end of the program

At the end of a program, the In-operation indicator light will be visible flashing slowly with the door shut. The buzzer might also be sounding.

The program has finished when  End appears in the display and the door has opened slightly (if applicable).

In the QuickIntenseWash program, the door will not open until a few minutes after the program has finished.

The drying fan may continue to run for a few minutes at the end of the program.

- Open the door fully so that the door locking pins retract again.

You can now empty the dishwasher.

The In-operation indicator light will go out 10 minutes after the end of the program if the door is closed.



If you have deactivated the automatic door opening function (see “Settings menu, AutoOpen”), but would still like to open the door at the end of the program, make sure that you open the door fully. Otherwise steam from the dishwasher could damage the edge of the counter because the fan is no longer running.

## Turning off the dishwasher

At the end of a program:

- Open the door.
- The dishwasher can be switched off at any time using the  button.

Switching the dishwasher off during a program stops the program.

Turning the dishwasher off during the run-up to a delay start time (FlexiTimer) will also stop the process.

If the dishwasher is not going to be used for a longer period of time, e.g., while on vacation, the water supply should be turned off.

## Unloading the dishwasher

Dishes tend to break and chip more easily when they are hot. Allow the dishes to cool until they are comfortable enough to handle before unloading them.

The dishes will cool much faster if you open the door when the program has ended.

First unload the lower basket, then the upper basket, and finally the cutlery tray (depending on model).

This will prevent water drops from the upper basket and cutlery tray from falling onto the dishes in the lower basket.

## Interrupting a program

The program will be interrupted as soon as you open the door.

After four seconds, the indicator light of the selected program will flash and the message Continue with OK will appear in the display.

- Press the OK and close the door within four seconds.

The program will continue from the point at which it was interrupted.





Water in the dishwasher may be hot. Danger of scalding! Only open the door if absolutely necessary and exercise extreme caution when doing so. Before closing the door again, leave it ajar for approx. 20 seconds. This will enable the temperature in the wash cabinet to settle. After that, press the OK and close the door within four seconds.

## Changing a program

If the detergent dispenser flap has already opened, do not change the program.

If a program has already started and you wish to change it, proceed as follows:

- Open the door.
- Turn the dishwasher off with the  button.
- Turn the dishwasher on again with the  button.
- Select the desired program.
- Start the program by closing the door within four seconds.

The Optical Interface comes on to show that a program has been started.

## Program overview

Program	When to use	Program sequence				
		Pre-wash	Main wash °F/°C	Interim rinse	Final rinse °F/°C	Drying
Normal <sup>1)</sup>	Program for regular use to completely wash a full load of normally soiled dishes with the ability to adjust energy and water consumption based on the soil load of the dishes.	As needed	117-140/ 47-60	X	140/ 60	X
Pots & Pans	For heavily soiled dishes and normally soiled pots, pans and utensils with dried on residue; use 20% more detergent than recommended.	2X	167/ 75	X	136/ 58	X
China & Crystal ☞	For temperature sensitive glassware and lightly soiled dishes, use 50% detergent recommended. GlassCare program for temperature-sensitive glasses and dishes with light soiling. Use 50% of the detergent amount.	X	113/ 45	X	136/ 58	X
Quick Intense-Wash	"Quick program" for standard dishes soiling that has not dried on.		149/ 65	X	140/ 60	X
SaniWash	To sanitize dishware, e.g. baby bottles, cutting boards and preparation dishes.		156/ 69	2X	158/ 70	X
Rinse & Hold	To rinse dishes when a complete program is not needed.	X				

1) This program is the most efficient in terms of its combined energy and water consumption for cleaning normally soiled crockery.

This program is used for energy labeling purposes.

Consumption <sup>2)</sup>			Duration <sup>2)</sup>	
Energy		Water		
Cold water 50°F/10°C kWh	Hot water 120°F/49°C kWh	Gallons/Liters	Cold water 50°F/10°C h:min	Hot water 120°F/49°C h:min
0.92	1.11	3.2/12.1	2:38	2:00
1.25	1.55	3.8/14.5	3:38	3:07
0.80	1.05	3.4/13.0	2:33	2:03
1.15	1.25	3.0/11.5	1:15	0:58
1.40	1.65	3.3/12.5	3:02	2:31
0.01	0.20	1.1/4.0	0:14	0:14

2) Values quoted are in accordance with 10 CFR 430 / C373-04. In practice there may be variations to these figures due to variable conditions and data recorded by the sensors. Durations shown will reflect your household conditions.

Selecting program options will also affect consumption levels and program durations (see “Programme options”).

The energy consumption with a hot water supply includes the energy used to heat the water (exception: EnergySaver, if available).



Program	When to use	Program sequence				
		Pre-wash	Main wash °F/°C	Interim rinse	Final rinse °F/°C	Drying
Extra Quiet	Extra quiet program for mixed loads with standard, slightly dried-on food residue with a longer program duration.		115/46	X	131/55	X
Economy	Water and energy saving program for standard dishes soiling that has not dried on, with a long soaking time and a low temperature.		129/54	X	111/44	X
Energy Saver	The water intake temperature must be 115°F (45°C) for light to normally soiled dishes.	2X	X	X	X	X
Grates & Filters	Wash program for cleaning Miele grates, the Miele griddle plate, and Miele ventilation hood filters.	X	167/75	X	136/58	X
Clean Machine	Special cleaning program to remove grease deposits from the dishwasher.		167/75	2X	158/70	X
Sensor Wash	Program for dried-on remains and non-sensitive loads. Temperature, waterintake, program duration and electricity consumption are automatically adjusted to suit the level of soiling of the dishes.	As needed	113-149/ 45-65	As needed	140-60	X

Consumption <sup>2)</sup>			Duration <sup>2)</sup>	
Energy		Water		
Cold water 50°F/10°C kWh	Hot water 120°F/49°C kWh	Gallons/Liters	Cold water 50°F/10°C h:min	Hot water 120°F/49°C h:min
0.80	1.00	2.5/9.5	4:35	4:28
0.65	0.85	2.5/9.5	3:58	3:25
	0.06	7.1/27.0		2:00
1.40	1.70	3.8/14.5	4:00	3:25
2.00	2.30	5.7/21.5	3:07	2:35
0.75 <sup>3)</sup> -1.15 <sup>4)</sup>	0.85 <sup>3)</sup> -1.50 <sup>4)</sup>	1.7/4.0 <sup>3)</sup> - 6.5/15.0 <sup>4)</sup>	1:57-3:59	1:46-3:33

2) Values quoted are in accordance with 10 CFR 430 / C373-04. In practice there may be variations to these figures due to variable conditions and data recorded by the sensors. Durations shown will reflect your household conditions.

Selecting program options will also affect consumption levels and program durations (see “Programme options”).

The energy consumption with a hot water supply includes the energy used to heat the water (exception: EnergySaver, if available).

3) Part load with light soiling

4) Full load with heavy soiling

## Cleaning and care

Check and clean your dishwasher regularly. This will help avoid problems and faults.



All surfaces are susceptible to scratching. Contact with unsuitable cleaning agents can alter or discolor all surfaces.

### Cleaning the wash cabinet

Generally, the wash cabinet is self cleaning if the correct amount of detergent is used.

If, however, there are limescale or grease deposits in the wash cabinet, these can be removed with a special cleaning agent (available from Miele). Follow the instructions on the packaging.

If you mainly use low temperature programs (< 120°F/50 °C), there is a risk of bacteria and unpleasant odors building up in the wash cabinet. To prevent this happening the dishwasher will automatically increase the temperature in the final rinse of the selected program after several programs using low temperatures have been run.

- Clean the filters in the wash cabinet regularly.

### Cleaning the door and the door seal

Bacteria could build up on the door seal and the sides of the dishwasher door as these surfaces are outside the wash cabinet and are not accessed and cleaned by the spray arm jets.

- Wipe the door seals regularly with a damp cloth to remove food deposits.
- Wipe off any food or drink residues which may have dripped onto the sides of the dishwasher door before closing it.

### Cleaning the control panel

- The control panel should only be wiped with a damp cloth.

### Cleaning the indicator reflector panel

The indicator reflector panel for the Optical Interface / TimeControl function (depending on model) is situated in the cover plate underneath the counter.

- The indicator reflector panel should only be wiped with a damp cloth or a suitable cleaning agent designed for use on plastic.

## Cleaning the door front



If soiling remains longer, it may happen that the surfaces can become discolored or changed. Remove any soiling immediately.

- Clean the front with a solution of warm water and a little dishwashing liquid applied with a soft sponge. Wipe the surfaces dry using a soft cloth.



Glass cleaners may be used to clean the exterior. However do not allow them to sit or “puddle”, this can cause damage to the surface. Remove the cleaner promptly.

### To better maintain your appliance avoid the following:

- Cleaning products containing soda, ammonia, acid, or chloride
- Descaling agents
- Abrasive cleaning products, such as scouring powder, scouring liquid, or pumice stones,
- Cleaners containing solvents
- Stainless steel cleaners
- Dishwasher cleaner
- Oven cleaners
- Glass cleaner
- Hard, abrasive brushes or sponges, e.g., pot scourers, brushes or sponges which have been previously used with abrasive cleaning agents
- Eraser sponges
- Sharp metal scrapers
- Steel wool
- Steam cleaning appliances

## Filter system

The filter system in the base of the wash cabinet prevents food from being redeposited on dishes. It also protects the circulation pump from damage caused by foreign objects.



This dishwasher must not be used without all the filters in place!

Collection of coarse soil may cause the filters to clog. The level of soiling and time it takes before the filters need cleaning will vary depending on use.

The message Check filters will appear in the display after every 50 program cycles (factory default setting).

You can set the interval for the “Check filters” message to appear to a value between 30 and 60 program cycles (see “Settings menu - Check filters”).

- Check the filter system.
- Clean it if necessary.
- Then confirm the message with OK. The message will go out.

## Filter system

- Turn the dishwasher off.

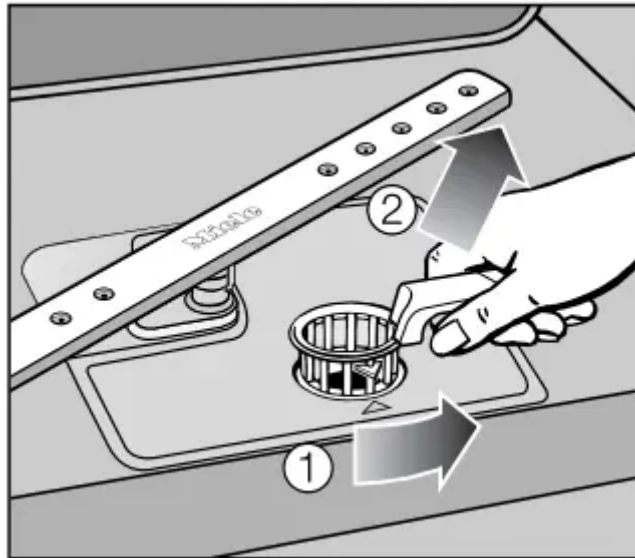

- Turn the handle counter-clockwise to release the filter system 1.
- Lift the filter system out of the dishwasher 2. Remove any coarse particles and rinse the filter well under running water. Use a nylon brush if necessary.



Ensure that coarse soil does not get into the circulation system and cause a blockage.

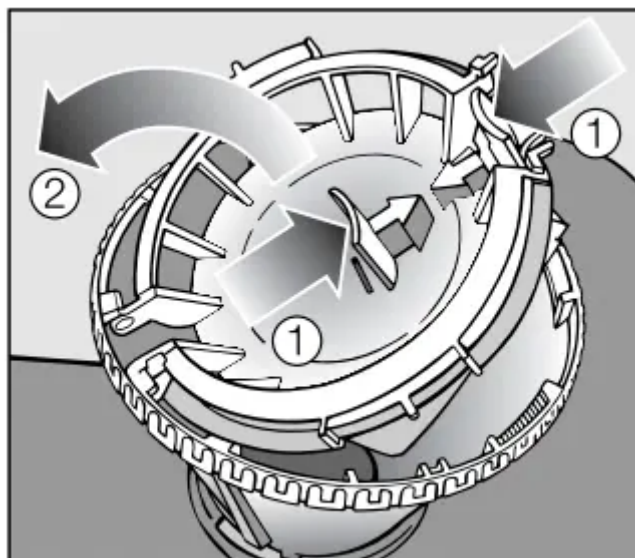

To clean the inside of the filter, the flap must be opened:

- Press catches 1 together in the direction of the arrows as shown, and open the filter 2.
- Rinse all the filters under running water.
- Then close the flap so that the catch engages.

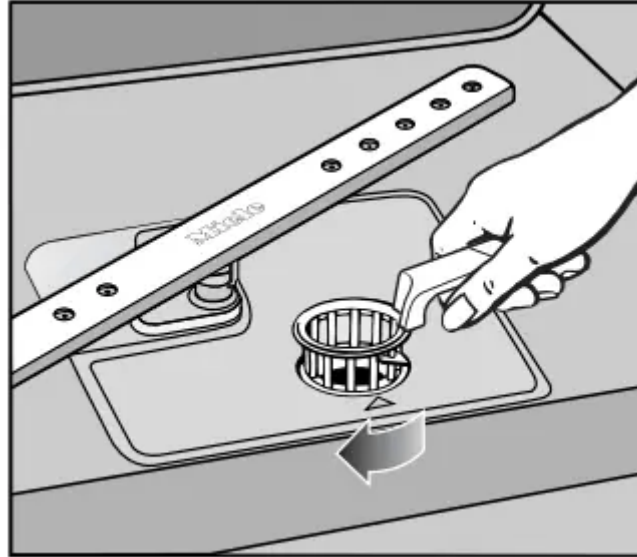

- Replace the filter system so that it lies flat in the base of the wash cabinet.
- Then turn the handle clockwise until both arrows point towards each other. This will lock the filter system in place.



Take care when you are fitting the filter system that it is secured in position correctly. Otherwise coarse soil could get into the circulation system and cause a blockage.

## Cleaning the spray arms

Particles of food can get stuck in the spray arm jets and bearings. The spray arms should therefore be inspected and cleaned regularly (approx. every 4 - 6 months).

- Turn the dishwasher off. Remove the spray arms as follows:
- Take out the cutlery tray (if your dishwasher is fitted with one).
- Push the top spray arm upwards to engage the inner ratchet. Then unscrew the spray arm.

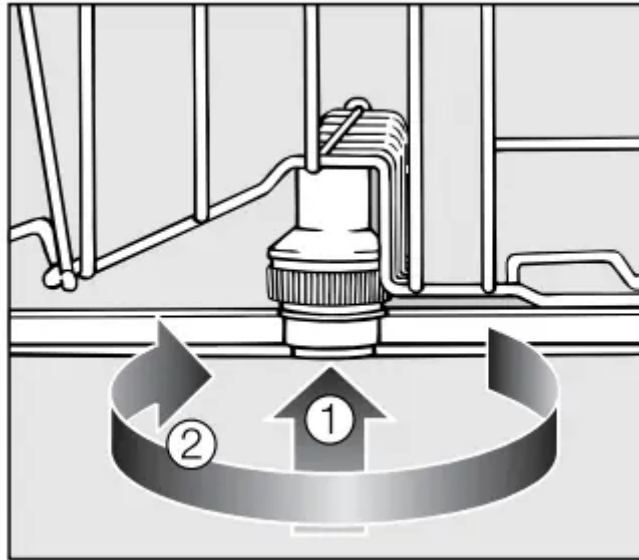

- Push the middle spray arm upwards 1 to engage the ratchet. Then unscrew the spray arm 2.
- Remove the lower basket.

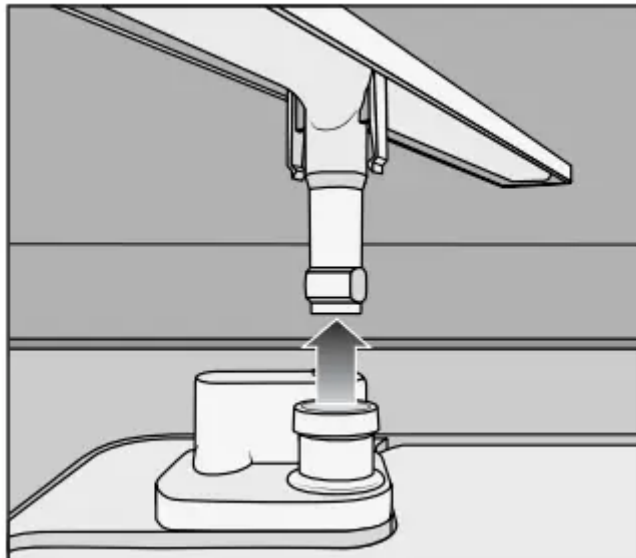

- Pull the lower spray arm firmly upwards to remove it.

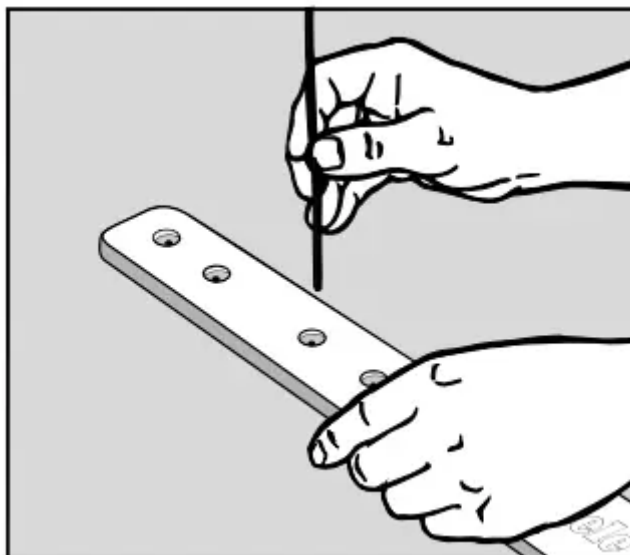

- Use a pointed object to push the food particles that are stuck in the spray arm jets into the spray arm.
- Rinse the spray arms thoroughly under running water.
- Replace the spray arms and check that they rotate freely.

## Frequently Asked Questions

With the help of the following guide, minor faults in the performance of the appliance, some of which may result from incorrect operation, can be put right without contacting Miele Service. This will save time and money.





The following guide may help you to find the reason for a fault, and to correct it. You should, however, note the following:







Unauthorized or incorrect repairs could cause personal injury or damage to the appliance. Repair work to electrical appliances must only be carried out by a suitably qualified and competent person in strict accordance with current local and national safety regulations. The manufacturer cannot be held liable for unauthorized work.

## Technical problems



Problem	Possible cause and solution
<p><b>The dishwasher does not start.</b></p>	<p>The door is not properly closed.</p> <ul style="list-style-type: none"> <li>• Push the door firmly shut.</li> </ul>
	<p>The dishwasher is not plugged in.</p> <ul style="list-style-type: none"> <li>• Insert the plug.</li> </ul>
	<p>The circuit breaker has tripped.</p> <ul style="list-style-type: none"> <li>• Reset the fuse (see data plate for the correct fuse rating).</li> </ul>
	<p>The dishwasher is not switched on.</p> <ul style="list-style-type: none"> <li>• Turn the dishwasher on with the  button.</li> </ul>
<p><b>The dishwasher stops during a program.</b></p>	<p>The circuit breaker has tripped.</p> <ul style="list-style-type: none"> <li>• Reset the fuse (see data plate for the correct fuse rating).</li> <li>• If the circuit breaker trips again, contact Miele Service.</li> </ul>
<p><b>After the program has started, the Optical Interface is not visible.</b></p>	<p>The indicator reflector panel was not correctly fitted.<sup>†</sup> Refit the indicator reflector panel correctly (see the installation plan).</p>
<p><b>The buzzer is sounding. The program will not start.</b></p> <p><b>The In-operation indicator light is not lit up.</b></p>	<p>The door has not closed properly, because it had not been fully opened after the door had been opened automatically.</p> <ul style="list-style-type: none"> <li>• Open the door fully so that the door locking pins retract again.</li> <li>• Then close the door.</li> </ul>

<p><b>The Optical Interface is flashing quickly.</b></p> <p><b>The buzzer is sounding. One of the following faults appears in the display:</b></p>	<p>Before fixing the fault:</p> <ul style="list-style-type: none"> <li>• Turn the dishwasher off with the  button.</li> </ul>
<p> <b>Fault FXX</b></p>	<p>There may be a technical fault.</p> <p>After a few seconds:</p> <ul style="list-style-type: none"> <li>• Turn the dishwasher back on.</li> <li>• Select the desired program.</li> <li>• Close the door.</li> </ul> <p>If the error message is displayed again, there is a technical fault.</p> <ul style="list-style-type: none"> <li>• Contact Miele Service.</li> </ul>
<p> <b>Waterproof</b></p>	<p>The WaterProof System has reacted.</p> <ul style="list-style-type: none"> <li>• Turn off the water supply.</li> <li>• Contact Miele Service.</li> </ul>
<p> <b>Fault F78</b></p>	<p>A fault has occurred in the circulation pump.</p> <ul style="list-style-type: none"> <li>• Turn the dishwasher off for at least 30 seconds with the  button.</li> <li>• Turn the dishwasher back on.</li> <li>• Select the desired program.</li> <li>• Close the door.</li> </ul> <p>If the error message is displayed again, there is a technical fault.</p> <ul style="list-style-type: none"> <li>• Contact Miele Service.</li> </ul>

## Water intake fault

Problem	Possible cause and solution
<p>The In-operation indicator light is flashing quickly.</p> <p>The buzzer is sounding. One of the following faults appears in the display:</p>	
<p> Open water supply</p>	<p>The water supply is turned off.</p> <ul style="list-style-type: none"> <li>• Turn on the water supply fully.</li> </ul>
<p> Intake</p>	<p>Before fixing the fault:</p> <ul style="list-style-type: none"> <li>• Turn the dishwasher off with the  button.</li> </ul>
	<p>There is a problem with the water intake.</p> <ul style="list-style-type: none"> <li>• Turn on the water supply fully and start the program again.</li> <li>• Clean the water intake filter (see “Frequently asked questions”).</li> <li>• The water pressure at the intake is lower than 4.35 psi.</li> </ul> <p>Contact a plumber.</p>
<p>The following message appears in the display during the Energy Saver program:</p> <p> Intake temp. low</p>	<p>The intake water has not reached the required temperature of 120°F (45°C) (see “Water connection, Water intake”).</p> <ul style="list-style-type: none"> <li>• Start the program again.</li> <li>• If the fault message appears again, select a different program.</li> </ul>

## Water drainage fault

Problem	Possible cause and solution
<p>The Optical Interface is flashing quickly.</p> <p>The buzzer is sounding. The following fault appears in the display:  Drain</p>	<p>Before fixing the fault:</p> <ul style="list-style-type: none"> <li>• Turn the dishwasher off with the  button.</li> </ul> <p>There is a problem with the water intake.</p> <p>There might be water in the wash cabinet.</p> <ul style="list-style-type: none"> <li>• Clean the filter system (see “Cleaning and care - Filter system”).</li> <li>• Clean the drain pump (see “Frequently asked questions”).</li> <li>• Clean the non-return valve (see “Frequently asked questions”).</li> <li>• Remove any kink or loop in the drain hose.</li> </ul>

## General problems

Problem	Possible cause and solution
<p><b>The Optical Interface is flashing quickly.</b></p> <p><b>The warning buzzer is sounding.</b></p> <p><b>The indicator light of the selected program and the message Continue with OK will appear in the display.</b></p> <p><b>The dishwasher does not start or the Flex- iTimer stops running.</b></p>	<p>The safe mode of the dishwasher was activated. The following takes place:</p> <ul style="list-style-type: none"> <li>– If you do not close the door within four seconds of the last press of a button at program start</li> <li>– If the door is open for longer than four seconds during a program or within the delay start time <ul style="list-style-type: none"> <li>• Press the OK and close the door within four seconds.</li> </ul> </li> </ul>
<p><b>The interior lighting does not switch on when the door is opened.</b></p>	<p>The interior lighting has been switched off.</p> <ul style="list-style-type: none"> <li>• Switch the lighting back on again (see “Settings menu - BrilliantLight”).</li> </ul>
<p><b>Detergent residue is left in the dispenser at the end of a program.</b></p>	<p>The dispenser was still damp when detergent was added.</p> <ul style="list-style-type: none"> <li>• Make sure the dispenser is dry before adding detergent.</li> </ul>
<p><b>The dispenser cover cannot be closed.</b></p>	<p>Detergent residue is blocking the latch.</p> <ul style="list-style-type: none"> <li>• Remove the detergent residue.</li> </ul>
<p><b>The inside of the door and/or the interior walls are wet after a program has finished.</b></p>	<p>This is caused by the drying system and does not indicate a fault. The moisture will dissipate after a while.</p>
<p><b>Water remains in the wash cabinet at the end of a program.</b></p>	<p>Before fixing the fault:</p> <ul style="list-style-type: none"> <li>• Turn the dishwasher off with the  button.</li> </ul> <p>The filter system in the wash cabinet is clogged.</p> <ul style="list-style-type: none"> <li>• Clean the filter system (see “Cleaning and care - Filter system”).</li> </ul>

	<p>The drain pump or non-return valve is blocked.</p> <ul style="list-style-type: none"> <li>• Clean the drain pump or the non-return valve (see “Frequently asked questions”).</li> </ul>
	<p>The drain hose is kinked.</p> <ul style="list-style-type: none"> <li>• Remove the kink.</li> </ul>

## Noises

<b>Problem</b>	<b>Possible cause and solution</b>
<b>There is a knocking noise in the wash cabinet.</b>	<p>A spray arm is hitting the dishes.</p> <ul style="list-style-type: none"> <li>• Interrupt the program, and rearrange the items which are obstructing the spray arm.</li> </ul>
<b>There is a rattling noise in the wash cabinet.</b>	<p>Dishes is moving around in the wash cabinet.</p> <ul style="list-style-type: none"> <li>• Interrupt the program and rearrange loose pieces.</li> </ul>
	<p>A foreign object (e.g., a cherry pit) has become lodged in the drain pump.</p> <ul style="list-style-type: none"> <li>• Remove the foreign object from the drain pump (see “Maintenance - Cleaning the drain pump and non-return valve”).</li> </ul>
<b>There is a knocking noise from the water pipe</b>	<p>This may be caused by the installation or the diameter of the water pipe.</p> <ul style="list-style-type: none"> <li>• This has no influence on dishwasher function. If in doubt, contact a suitably qualified plumber.</li> </ul>

## Poor cleaning results



Problem	Possible cause and solution
<p><b>The dishes are not clean.</b></p>	<p>The dishes were not loaded correctly.</p> <ul style="list-style-type: none"> <li>• See notes in “Loading the dishwasher”.</li> </ul>
	<p>The program was not powerful enough.</p> <ul style="list-style-type: none"> <li>• Select a more intensive program (see “Program overview”).</li> </ul>
	<p>Not enough detergent was dispensed.</p> <ul style="list-style-type: none"> <li>• Use more detergent, or change your detergent.</li> </ul>
	<p>Items are blocking the path of the spray arms.</p> <ul style="list-style-type: none"> <li>• Rearrange the items so that the spray arms can rotate freely.</li> </ul>
	<p>The filter system in the base of the wash cabinet is not clean or is not correctly fitted.</p> <p>This may cause the spray arm jets to get blocked.</p> <ul style="list-style-type: none"> <li>• Clean and/or fit the filter system correctly.</li> <li>• Clean the spray arm jets if necessary (see “Cleaning and care - Cleaning the spray arms”).</li> </ul>
	<p>The non-return valve is open and blocked. Dirty water has flowed back into the wash cabinet.</p> <ul style="list-style-type: none"> <li>• Clean the drain pump and the non-return valve (see “Frequently asked questions”).</li> </ul>



**Smearing appears on glassware and cutlery.  
There is a bluish sheen on the surface of  
glassware; film can be wiped off.**

The rinse aid dosage is set too high.

- Reduce the dosage (see “Settings menu - Rinse aid”).

<b>Dishes is not dry or cutlery and glasses are spotty.</b>	<p>The rinse aid dosage is set too low or the rinse aid reservoir is empty.</p> <ul style="list-style-type: none"> <li>• Replenish the reservoir, increase the dosage, or change the brand of rinse aid (see “Before using for the first time - Rinse aid”).</li> </ul>
	<p>Dishes was taken out of the cabinet too soon.</p> <ul style="list-style-type: none"> <li>• Leave it in for longer (see “Operation”).</li> </ul>
	<p>Combination tabs have been used which have im- paired drying performance.</p> <ul style="list-style-type: none"> <li>• Change your detergent, or replenish the rinse aid (see “Before using for the first time - Rinse aid”).</li> </ul>
<b>Glasses have a brownish-blue discoloration; the deposit cannot be wiped off.</b>	<p>Detergent deposits.</p> <ul style="list-style-type: none"> <li>• Switch to another detergent.</li> </ul>
<b>Glasses are dull and discolored; the deposit cannot be wiped off.</b>	<p>The glassware is not dishwasher-safe. The surfaces are affected.</p> <ul style="list-style-type: none"> <li>• There is no remedy.</li> </ul> <p>Purchase glassware which is dishwasher-safe.</p>
<b>Tea or lipstick stains have not been completely removed.</b>	<p>The wash temperature of the selected program was too low.</p> <ul style="list-style-type: none"> <li>• Select a program with a higher wash temperature.</li> </ul>
	<p>The bleaching effect of the detergent is too low.</p> <ul style="list-style-type: none"> <li>• Switch to another detergent.</li> </ul>
<b>Plastic parts are discolored.</b>	<p>Natural dyes, e.g., from carrots, tomatoes, or ketchup may be the cause. The amount of detergent used or its bleaching effect was not sufficient to deal with natural dyes.</p> <ul style="list-style-type: none"> <li>• Use more detergent (see “Operation - Detergent”).</li> </ul> <p>Discoloration is irreversible.</p>

<p><b>White residue is visible on dishes and cutlery, clouding occurs on glassware; this film can be wiped off.</b></p>	<p>The rinse aid dosage is too low.</p> <ul style="list-style-type: none"> <li>• Increase the dosage (see “Settings menu, Rinse aid”).</li> </ul>
	<p>The salt reservoir is empty.</p> <ul style="list-style-type: none"> <li>• Fill the salt reservoir (see “Before using for the first time, Dishwasher salt”).</li> </ul>
	<p>The salt reservoir cap has not been screwed on correctly.</p> <ul style="list-style-type: none"> <li>• Replace it, making sure that it screws back on correctly.</li> </ul>
	<p>An unsuitable Tab detergent has been used.</p> <ul style="list-style-type: none"> <li>• Change your detergent.</li> </ul>
	<p>The softener assembly is programmed too low for the water hardness level.</p> <ul style="list-style-type: none"> <li>• Program the softener assembly to a higher water hardness level (see “Settings menu, Water hardness”).</li> </ul>
<p><b>There are rust stains on the cutlery.</b></p>	<p>The affected items are not corrosion resistant.</p> <ul style="list-style-type: none"> <li>• There is no remedy.</li> </ul> <p>Purchase cutlery which is dishwasher-safe.</p>
	<p>A program was not run after dishwasher salt was added. Traces of salt have got into the wash cycle.</p> <ul style="list-style-type: none"> <li>• Always run the QuickIntenseWash program with the Short programming option selected and without any dishes in the dishwasher after adding dishwasher salt.</li> </ul>
	<p>The salt reservoir cap has not been screwed on correctly.</p> <ul style="list-style-type: none"> <li>• Replace it, making sure that it screws back on correctly.</li> </ul>

## Cleaning the drain pump and non-return valve

If the water has not been pumped away at the end of a program, the drain pump or the non-return valve might be blocked. They are, however, easy to clean.

- Disconnect the dishwasher from the electrical supply. Turn off the dishwasher and withdraw the plug.
- Take the filter system out of the wash cabinet (see “Cleaning and care, Cleaning the filters”).
- Scoop the water out of the wash cabinet using a suitable container or utensil.

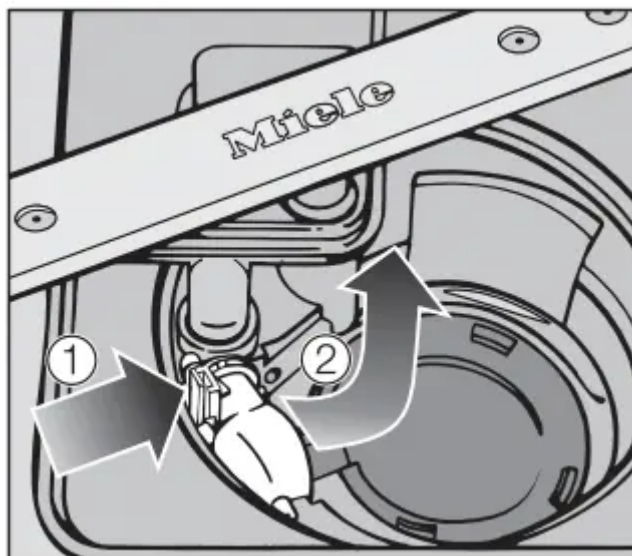

- Press the catch for the non-return valve inwards 1.
- Tilt the non-return valve inwards until it is released 2.
- Rinse it thoroughly under running water and remove any dirt from the nonreturn valve.

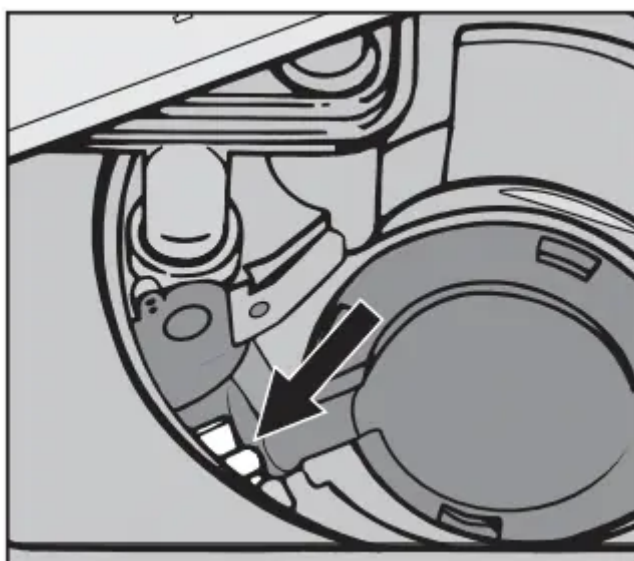

The drain pump is located underneath the non-return valve (see arrow).

- Remove all foreign objects from the drain pump (glass or bone splinters). Before returning the non-return valve, check that the drain pump is not blocked. Spin the impeller several times in both directions to check for obstructions.
- Carefully reinsert the non-return valve and secure it with the locking clamp.



Make sure the locking clamp clicks into place!



Be careful not to damage any delicate components when cleaning the drain pump and the non-return valve.

### **Warning**

This content is compiled from multiple sources and is provided for reference purposes only. It may not be complete or fully applicable to all situations. If you are unable to resolve your issue, please contact the product manufacturer or an authorized service provider for official support.