

PRODUCT DESCRIPTION

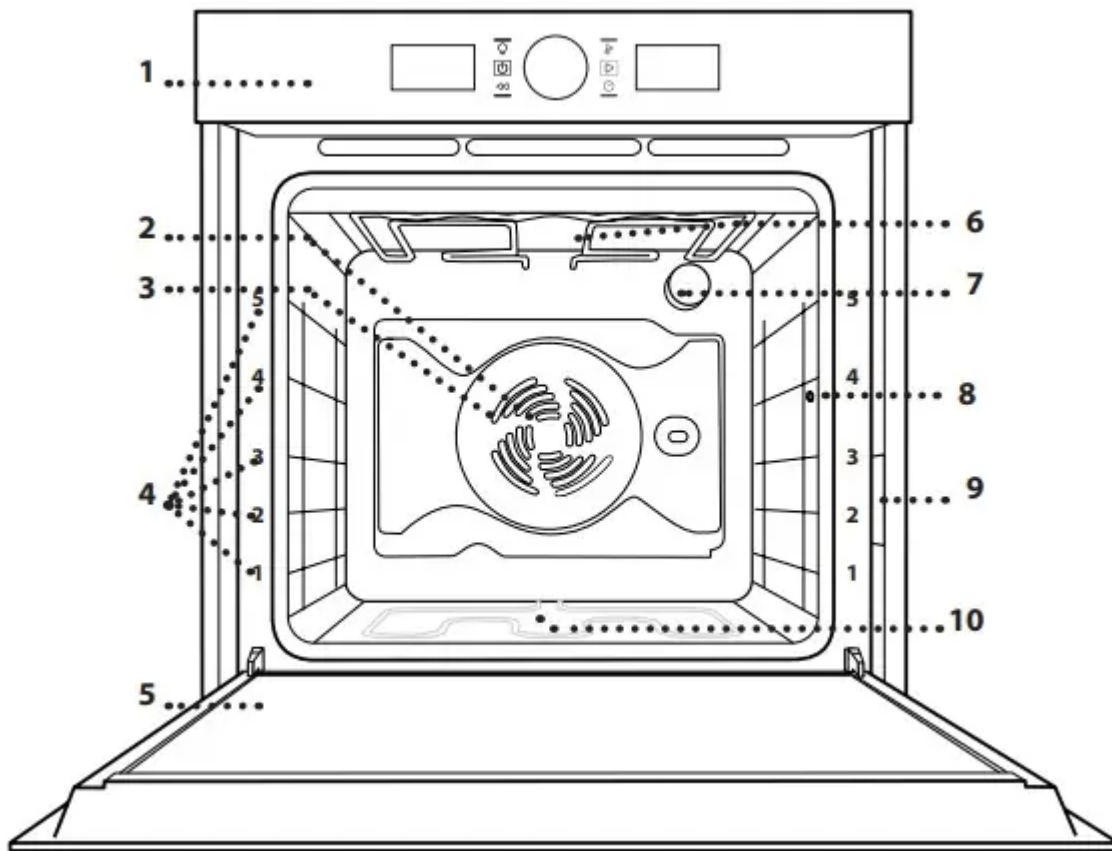

1. Control panel
2. Fan
3. Circular heating element (not visible)
4. Shelf guides (the level is indicated on the front of the oven)
5. Door
6. Upper heating element/grill
7. Lamp
8. Meat probe insert point (if present)
9. Identification plate (do not remove)
10. Lower heating element (not visible)

CONTROL PANEL

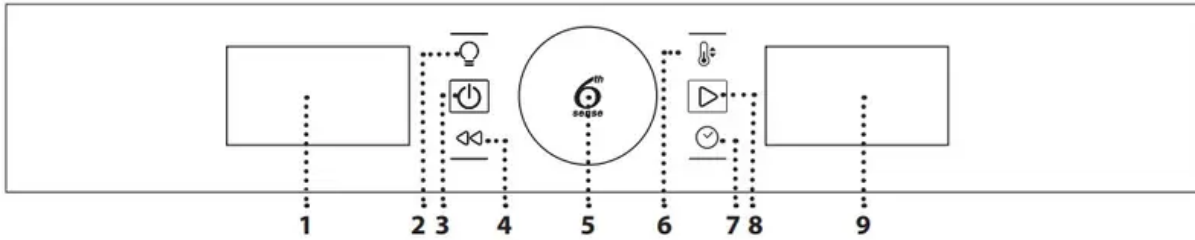

1. LEFT-HAND DISPLAY

2. LIGHT

For switching the lamp on/off.

3. ON/OFF

For switching the oven on and off and for stopping an active function at any time.

4. BACK

For returning to the previous menu when configuring settings.

5. ROTARY KNOB / 6TH SENSE BUTTON

Turn this to navigate through the functions and adjust all of the cooking parameters. Press



to select, set, access or confirm functions or parameters and eventually start the cooking program.

6. TEMPERATURE

For setting the temperature.

7. TIME





For setting or changing the time and adjusting the cooking time.

8. START

For starting functions and confirming settings.







9. RIGHT-HAND DISPLAY

FUNCTIONS

	<p>CONVENTIONAL</p> <p>For cooking any kind of dish on one shelf only.</p>
	<p>GRILL</p> <p>For grilling steaks, kebabs and sausages, cooking vegetables au gratin or toasting bread. When grilling meat, we recommend using a drip tray to collect the cooking juices: Position the tray on any of the levels below the wire shelf and add 500 ml of drinking water.</p>
	<p>FORCED AIR</p> <p>For cooking different foods that require the same cooking temperature on several shelves (maximum three) at the same time. This function can be used to cook different foods without odours being transferred from one food to another.</p>
	<p>CONVECTION BAKE</p> <p>For cooking meat, baking cakes with fillings or roasting stuffed vegetables on one shelf only. This function uses gentle, intermittent air circulation to prevent food from drying out excessively.</p>









6TH SENSE FUNCTIONS

	<p>CASSEROLE</p> <p>This function automatically selects the best temperature and cooking method for pasta dishes</p>
	<p>MEAT</p> <p>This function automatically selects the best temperature and cooking method for meat. This function intermittently activates the fan at low speed to prevent the food from drying out too much.</p>
	<p>MAXI COOKING</p> <p>The function automatically selects the best cooking mode and temperature to cook large joints of meat (above 2.5 kg). It is advisable to turn the meat over during cooking, to obtain even browning on both sides. It is best to baste the meat every now and again to prevent it from drying out.</p>
	<p>BREAD</p> <p>This function automatically selects the best temperature and cooking method for all types of bread.</p>
	<p>PIZZA</p> <p>This function automatically selects the best temperature and cooking method for all types of pizza.</p>
	<p>PASTRY CAKES</p> <p>This function automatically selects the best temperature and cooking method for all types of cake.</p>



SPECIAL FUNCTIONS

	<p>FAST PREHEATING</p> <p>For preheating the oven quickly. Once preheating has finished, the oven will select the “Conventional” function automatically. Wait for preheating to finish before placing food in the oven.</p>
	<p>TURBO GRILL</p> <p>For roasting large joints of meat (legs, roast beef, chicken). We recommend using a drip tray to collect the cooking juices: Position the pan on any of the levels below the wire shelf and add 500 ml of drinking water. The turnspit (if provided) can be used with this function.</p>
	<p>ECO FORCED AIR*</p> <p>For cooking stuffed roasting joints and fillets of meat on a single shelf. Food is prevented from drying out excessively by gentle, intermittent air circulation. When this ECO function is in use, the light will remain switched off during cooking. To use the ECO cycle and therefore optimise power consumption, the oven door should not be opened until the food is completely cooked.</p>
	<p>KEEP WARM</p> <p>For keeping just-cooked food hot and crisp.</p>
	<p>RISING</p> <p>For optimal proving of sweet or savoury dough. To maintain the quality of proving, do not activate the function if the oven is still hot following a cooking cycle.</p>
	<p>SMART CLEAN (ONLY IN SOME MODELS)</p> <p>The action of the steam released during this special low-temperature cleaning cycle allows dirt and food residues to be</p>

removed with ease. Pour 200 ml of drinking water on the bottom of the oven and only activate the function when the oven is cold.

DAILY USE

1. SELECT A FUNCTION

When the oven is off, only the time is shown on the display. Press and hold  to switch the oven on. Turn the knob to view the main functions available on the left-hand display.

Select one and press .



To select a sub-function (where available), select the main function and then press  to confirm and go to the function menu.

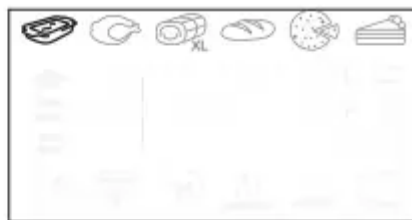
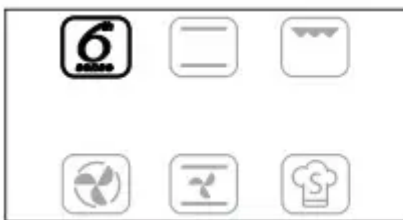

Turn the knob to view the sub-functions available on the right-hand display. Select one and press  to confirm.

2. SET THE FUNCTION

After having selected the function you require, you can change its settings.

The display will show the settings that can be changed in sequence.

TEMPERATURE/GRILL LEVEL



When the °C/°F icon flashes on the display, turn the knob to change the value, then press



to confirm and continue to alter the settings that follow (if possible).

You can also set the grill level (3 = high, 2 = medium, 1 = low) at the same time.





Please note: Once the function has started, you can change the temperature or the grill level

by pressing  or by turning the knob directly.

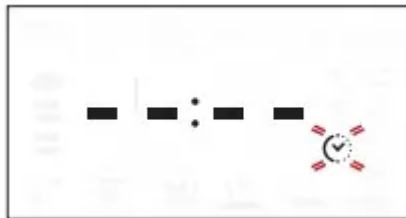
DURATION



When the  icon flashes on the display, use the adjustment knob to set the cooking time you require and then press  to confirm.

You do not have to set the cooking time if you want to manage cooking manually: Press



to confirm and start the function.

In this case, you cannot set the end cooking time by programming a delayed start.

Please note: You can adjust the cooking time that has been set during cooking by pressing :

Turn the knob to change the hour and press  to confirm.

SETTING THE END COOKING TIME/ DELAYED START

In many functions, once you have set a cooking time you can delay starting the function by programming its end time.

Where you can change the end time, the display will show the time the function is expected to finish while the  icon flashes.





If necessary, turn the knob to set the time you want cooking to end, then press  to confirm and start the function.

Place the food in the oven and close the door: The function will start automatically after the period of time that has been calculated in order for cooking to finish at the time you have set.





Please note: Programming a delayed cooking start time will disable the oven preheating phase. The oven will reach the temperature you require gradually, meaning that cooking times will be slightly longer than those listed in the cooking table.

During the waiting time, you can use the knob to change the programmed end time.

Press  or  to change the temperature and cooking time settings. Press  to confirm when finished.

3. ACTIVATE THE FUNCTION

Once you have applied the settings you require, press  to activate the function.

You can press  and hold at any time to pause the function that is currently active.

4. PREHEATING

Some functions have an oven preheating phase: Once the function has started, the display indicates that the preheating phase has been activated.



Once this phase has finished, an audible signal will sound and the display will indicate that the oven has reached the set temperature.



At this point, open the door, place the food in the oven, close the door and start cooking by pressing .

Please note: Placing the food in the oven before preheating has finished may have an adverse effect on the final cooking result.

Opening the door during the preheating phase will pause it..

The cooking time does not include a preheating phase.

You can always change the temperature you want to reach using the knob.

5. END OF COOKING

An audible signal will sound and the display will indicate that cooking is complete.



To extend the cooking time without changing the settings, turn the knob to set a new cooking time and press .

USEFUL TIPS

HOW TO READ THE COOKING TABLE

The table lists the best function, accessories and level to use to cook different types of food. Cooking times start from the moment food is placed in the oven, excluding preheating (where required). Cooking temperatures and times are approximate and depend on the amount of food and the type of accessory used. Use the lowest recommended settings to begin with and, if the food is not cooked enough, then switch to higher settings. Use the accessories supplied and preferably dark-coloured metal cake tins and baking trays. You can also use Pyrex or stoneware pans and accessories, but bear in mind that cooking times will be slightly longer.

COOKING DIFFERENT FOODS AT THE SAME TIME

Using the “Forced Air” function, you can cook different foods which require the same cooking temperature at the same time (for example: fish and vegetables), using different shelves. Remove the food which requires a shorter cooking time and leave the food which requires a longer cooking time in the oven.

MEAT

Use any kind of oven tray or pyrex dish suited to the size of the piece of meat being cooked. For roast joints, it is best to add some stock to the bottom of the dish, basting the meat during cooking for added flavour. Please note that steam will be generated during this operation. When the roast is ready, let it rest in the oven for another 10-15 minutes, or wrap it in aluminium foil.

When you want to grill meat, choose cuts with an even thickness all over in order to achieve uniform cooking results. Very thick pieces of meat require longer cooking times. To prevent the meat from burning on the outside, lower the position of the wire shelf, keeping the food farther away from the grill. Turn the meat two thirds of the way through cooking. Take care when opening the door as steam will escape.

To collect the cooking juices, we recommend placing a dripping pan filled with half a litre of drinking water directly underneath the wire shelf on which the food is placed. Top-up when necessary

DESSERTS

Cook delicate desserts with the conventional function on one shelf only.

Use dark-coloured metal baking pans and always place them on the wire shelf supplied. To cook on more than one shelf, select the forced air function and stagger the position of the cake tins on the shelves, aiding optimum circulation of the hot air.

To check whether a leavened cake is cooked, insert a wooden toothpick into the centre of the cake. If the toothpick comes out clean, the cake is ready.

If using non-stick baking pans, do not butter the edges as the cake may not rise evenly around the edges.

If the item “swells” during baking, use a lower temperature next time and consider reducing the amount of liquid you add or stirring the mixture more gently.

For desserts with moist fillings or toppings (such as cheesecake or fruit tarts), use the “Convection bake” function. If the base of the cake is soggy, lower the shelf and sprinkle the bottom of the cake with breadcrumbs or biscuit crumbs before adding the filling.

PIZZA

Lightly grease the trays to ensure the pizza has a crispy base. Scatter the mozzarella over the pizza two thirds of the way through cooking.

RISING

It is always best to cover the dough with a damp cloth before placing it in the oven. Dough proving time with this function is reduced by approximately one third compared to proving at room temperature (20-25°C). The rising time for pizza starts at around one hour for 1 kg of dough.

MAINTENANCE AND CLEANING

EXTERIOR SURFACES

- Clean the surfaces with a damp microfibre cloth. If they are very dirty, add a few drops of pH-neutral detergent. Finish off with a dry cloth.
- Do not use corrosive or abrasive detergents. If any of these products inadvertently comes into contact with the surfaces of the appliance, clean immediately with a damp microfibre cloth.

INTERIOR SURFACES

- After every use, leave the oven to cool and then clean it, preferably while it is still warm, to remove any deposits or stains caused by food residues. To dry any condensation that has formed as a result of cooking foods with a high water content, let the oven to cool completely and then wipe it with a cloth or sponge.
- Clean the glass in the door with a suitable liquid detergent.
- Activate the “Smart Clean” function for optimum cleaning of the internal surfaces (If present).
- The oven door can be removed to facilitate cleaning .
- The top heating element of the grill can be lowered to clean the upper panel of the oven.

ACCESSORIES

Soak the accessories in a washing-up liquid solution after use, handling them with oven gloves if they are still hot. Food residues can be removed using a washing-up brush or a sponge.

CLEANING THE CATALYTIC PANELS (ONLY IN SOME MODELS)

This oven is equipped with special catalytic panels that facilitate cleaning of the cooking compartment thanks to their special self-cleaning coating, which is highly porous and able to absorb grease and grime. These panels are fitted to the shelf guides: When repositioning and then refitting the shelf guides, make sure that the hooks at the top are slotted into the appropriate holes in the panels.

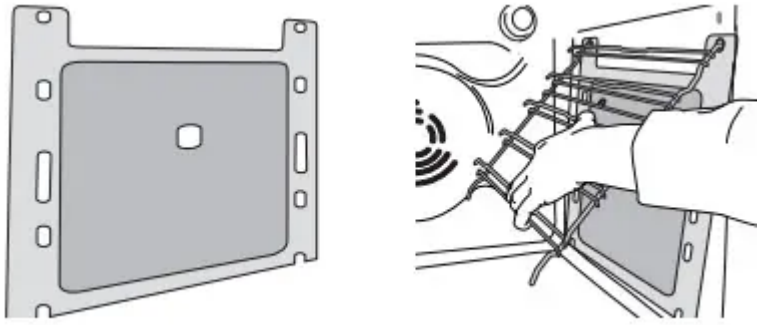

To make best use of the catalytic panels' self-cleaning properties, we recommend heating the oven to 200 °C for around one hour using the "Convection Bake" function. The oven must be empty during this time. Then leave the appliance to cool down before removing any remaining food residues using a nonabrasive sponge.

Please note: Using corrosive or abrasive cleaning agents, stiff brushes, pan scourers or oven sprays could damage the catalytic surface and compromise its self-cleaning properties.

Please contact our After-sales Service if you require replacement panels.

REPLACING THE LIGHT

1. Disconnect the oven from the power supply.
2. Unscrew the cover from the light, replace the bulb and screw the cover back on the light.
3. Reconnect the oven to the power supply.

Please note: Only use 20-40 W/230 ~ V type G9, T300°C halogen bulbs. The bulb used in the product is specifically designed for domestic appliances and is not suitable for general room lighting within the home (EC Regulation 244/2009). Light bulbs are available from our After-sales Service.

- If using halogen bulbs, do not handle them with your bare hands as your fingerprints could cause damage. Do not use the oven until the light cover has been refitted.

LOWER THE TOP HEATING ELEMENT (ONLY IN SOME MODELS)

1. Remove the lateral shelf guides.

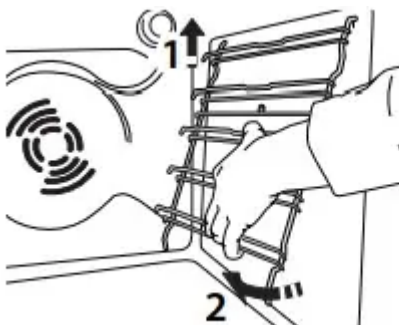

2. Pull the heating element out a little and lower it.

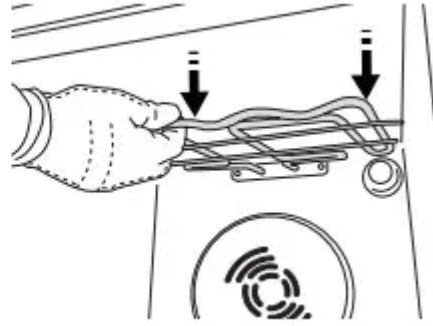
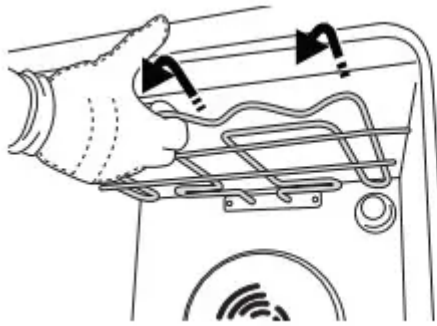

3. To reposition the heating element, lift it up, pulling it slightly towards you, making sure it comes to rest on the lateral supports.

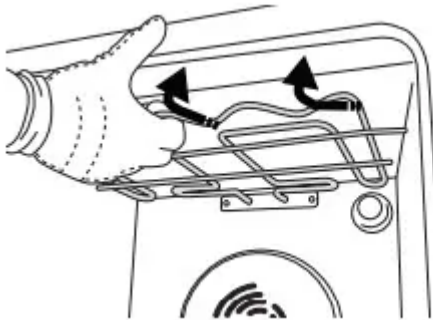

REMOVING AND REFITTING THE DOOR

1. To remove the door, open it fully and lower the catches until they are in the unlock position.
2. Close the door as much as you can. Take a firm hold of the door with both hands – do not hold it by the handle.

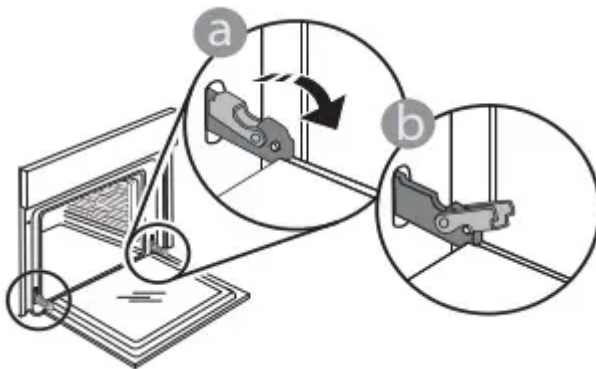

Simply remove the door by continuing to close it while pulling it upwards at the same time until it is released from its seating. Put the door to one side, resting it on a soft surface.

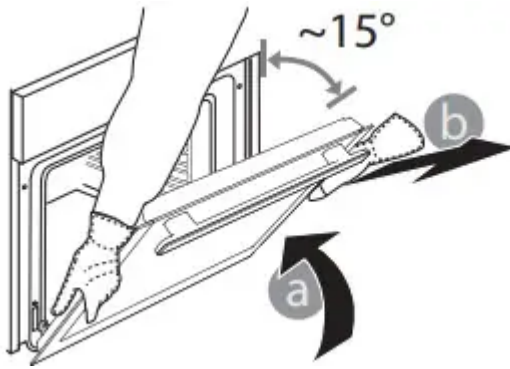

3. Refit the door by moving it towards the oven, aligning the hooks of the hinges with their seating and securing the upper part onto its seating.

4. Lower the door and then open it fully. Lower the catches into their original position: Make sure that you lower them down completely

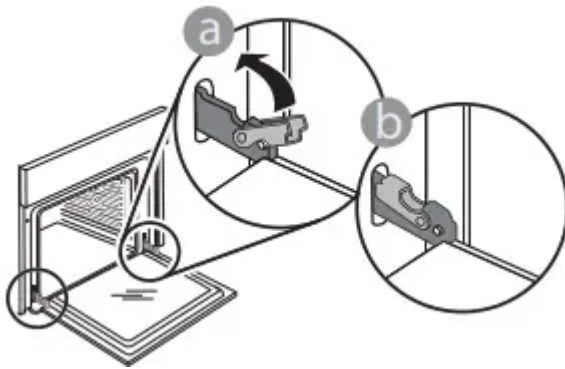

Apply gentle pressure to check that the catches are in the correct position.

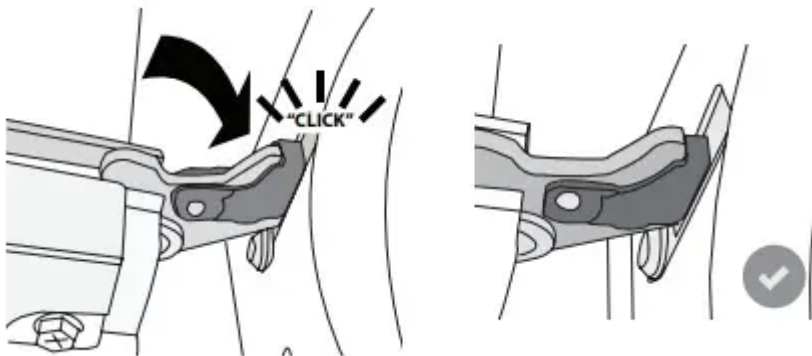

5. Try closing the door and check to make sure that it lines up with the control panel. If it does not, repeat the steps above: The door could become damaged if it does not work properly.

TROUBLESHOOTING

Problem	Possible cause	Solution
The oven is not working.	Power cut. Disconnection from the mains.	Check for the presence of mains electrical power and whether the oven is connected to the electricity supply. Turn off the oven and restart it to see if the fault persists.
The display shows the letter "F" followed by a number or letter.	Software problem.	Contact you nearest Client After-sales Service Centre and state the number following the letter "F".

Warning

This content is compiled from multiple sources and is provided for reference purposes only. It may not be complete or fully applicable to all situations. If you are unable to resolve your issue, please contact the product manufacturer or an authorized service provider for official support.