

BEFORE USING FOR THE FIRST TIME

DO NOT immerse this product in water. Wipe it with a moist cloth. Wash the lid, freezer bowl, mixing arm, condiment containers, condiment chute and drip tray in warm soapy water to remove any dust or residue from the manufacturing and shipping process. DO NOT clean any of the parts with abrasive cleaners or hard implements. DO NOT immerse unit in water or put unit under running water. Clean with a damp cloth only.

FREEZING TIME AND BOWL PREPARATION

The freezer bowl must be completely frozen before you begin your recipe. Before freezing, wash and dry the bowl. Wrap it in a plastic bag to prevent freezer burn. We recommend that you place the freezer bowl in the back of your freezer where it is coldest. **Be sure to place the freezer bowl on a flat surface in its upright position for even freezing.** The length of time needed to reach the frozen state depends on how cold your freezer is.

For the most convenient frozen desserts, leave your freezer bowl in the freezer at all times. You can take it out any time for immediate use. In general, freezing time should be a minimum of 12 hours. To determine whether the bowl is completely frozen, shake it. If you do not hear liquid moving, the cooling liquid is frozen.

Reminder: Your freezer should be set to 0°F to ensure proper freezing of all foods.

FEATURES AND BENEFITS

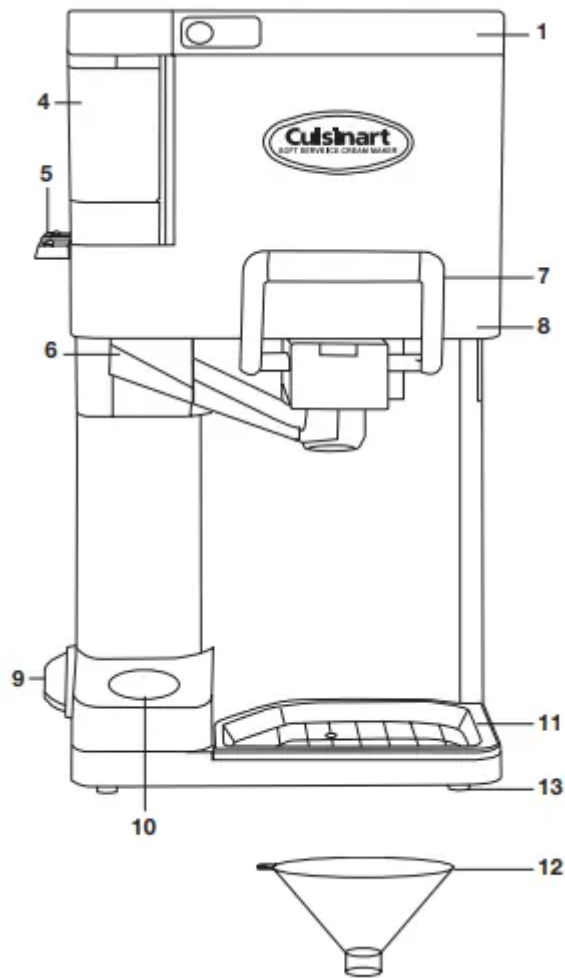

1. **Easy-lock Lid with Window** – Lid is designed to remove and lock easily. An ingredient window allows you to pour ingredients directly through the top and watch the freezing process.

2. **Mixing Arm (not shown)** – Mixes and aerates ingredients in freezer bowl to create smooth soft ice cream.

3. **1 1/2-Quart Freezer Bowl (not shown)** –

Contains cooling liquid within a

double-insulated wall to create fast and even freezing. Double wall keeps the bowl cool and at an even temperature.

4. **Three Condiment Containers** – Dispense the mix-ins of your choice. The front condiment container with a curved edge dispenses small mix-ins such as sprinkles. Two rectangular condiment containers dispense larger mix-ins such as mini M&M@s or mini chocolate morsels.

5. Condiment Dispensing Levers – Pull out one of three levers to add the mix-ins of your choice into your

soft ice cream.

6. Condiment Chute – Mix-ins are dispensed from the chute into your ice cream cone or bowl while you dispense ice cream. Removable for easy cleaning.

7. Dispensing Bracket with Handle – Dispenses the soft ice cream when handle is pulled down. Removable for easy cleaning.

8. Base – Contains heavy-duty motor strong enough to make and dispense ice cream.

9. ON/OFF Power Dial

10. Cone Holder – Conveniently holds a stack of extra ice cream cones. Can hold both flat and pointed-bottom cones.

11. Removable Drip Tray – Can be removed for easy cleaning. Dot in center of tray indicates where to place the ice cream cone.

12. Mix-in Gauge – Check the size of mix-ins by dropping them through. Mix-ins that do not fit through will clog the ice cream maker.

13. Rubber Feet – Nonslip feet keep base stationary during use.

ASSEMBLY

1. Insert the condiment containers into the indent on the top side of the ICE-45 so that they are firmly in place. The condiment container with the rounded edge should be inserted into the front space.

2. Place the small narrow cover over the condiment containers.

3. Attach the dispenser with handle by inserting the tab into the slot under the dispensing area, then push the dispenser upwards until it locks into place. (Make sure the handle is in the upright position.)

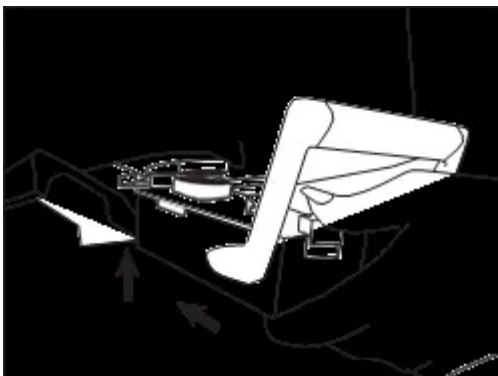

4. Slide the condiment chute into the space provided under the condiment containers. Be sure to slide it all the way in until it stops.

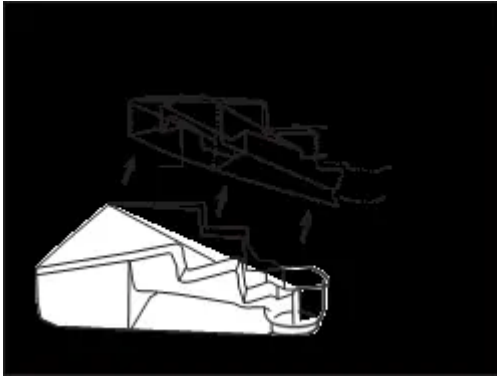

5. Place the drip tray on the base under the dispenser.

6. Push the mixing arm into the hole on the bottom of the lid.

7. Insert the freezer bowl. Make sure that it is securely in place.

8. Put the lid with mixing arm attached over the freezer bowl and push down until it clicks securely in place. To remove lid, push in and lift the two side tabs.



MAKING SOFT SERVE ICE CREAM AND FROZEN DESSERTS

1. Fill the condiment containers with the desired mix-ins. Place small mix-ins such as sprinkles in the front condiment container with the curved edge. Place large mix-ins such as mini M&M®s or mini chocolate morsels in the rectangular condiment containers.

NOTE: Do not place liquid condiments in the condiment containers.

2. Use Cuisinart's recipes from the pages that follow. Do not fill the freezer bowl higher than ½" from the top, as the ingredients will increase in volume during the freezing process. For best results, prepare ingredients in a container from which it is easy to pour.

3. Remove the freezer bowl from the freezer. (Remove plastic bag if you have wrapped freezer bowl.) Lift the lid and place freezer bowl inside the base.

NOTE: Bowl will begin to defrost quickly once it has been removed from freezer. Use it immediately after removing from freezer.

4. Push the mixing arm into the hole on the bottom of the lid.

5. Place lid with mixing arm on base and push down until it locks in place.

6. Turn the power dial to the ON position. Mixing arm will begin to turn.

7. Add ingredients to the freezer bowl by pouring them through the opening in the lid.

8. Soft ice cream will be finished in as little as 20 minutes. The time will depend on the recipe and volume of the dessert you are making. If ingredients are refrigerated, ice cream making time will be reduced.

NOTE: You must watch the ice cream to determine when to dispense. If you wait too long, ice cream may get too thick to dispense. If this happens, remove the bowl, scoop out and enjoy the ice cream.

9. Hold an ice cream cone or bowl one inch below the ice cream chute and pull down the handle to dispense the soft ice

cream. Turn cup or bowl as you dispense to swirl ice cream.

10. **Pull out** one, two or all three condiment dispensing levers to add the mix-ins of your choice into your soft ice cream or dessert. To stop the flow of mix-ins, push in the dispensing levers.

11. When finished filling the cone or bowl, push the handle back up to stop the flow of ice cream.

NOTES: Some liquid may initially come out of the dispensing bracket when the handle is first pulled down. Use a cup to collect this liquid, then proceed with filling the first bowl or cone.

Do not store frozen desserts in the freezer bowl. Desserts will stick to the side of the freezer bowl and may damage the bowl. Store only in an airtight container.

The ice cream will lose its soft consistency and harden after it is stored in the freezer.

RECOMMENDED MIX-INS

These items can be found in most well-stocked grocery stores and specialty grocery/gourmet food stores.

The location of the items will depend upon the individual store (for example, some items will be found near the ice cream and ice cream cones while others may be found in the baking section).

Mini M&M@s*

Mini chocolate morsels*

Confetti sprinkles

Chocolate sprinkles

Caramel sprinkles

Praline crunch

Critter crunch or other decorative crunch bits

Almond brickle bits/chips

***NOTE:** Do not use full sized M&M®s or chocolate morsels, they are too large to dispense. Use the mix-in gauge to make sure mix-ins are not too large. If they do not fit through the hole in the gauge, then they will clog the unit.

SAFETY FEATURE

The Cuisinart® Mix It In™ Soft Serve Ice Cream Maker is equipped with a safety feature that automatically stops the unit if the motor overheats. This may occur if the dessert is extremely thick or if the unit has been running for an excessively long period of time, or if added condiments are too large. If ice cream is too thick to dispense, remove the bowl and eat the ice cream.

DISASSEMBLING FOR CLEANING

- 1.Remove the lid and disconnect the mixing paddle.
- 2.Lift the freezer bowl up and out of the base.
- 3.Remove the condiment chute by pulling it toward you.
- 4.Remove the dispensing bracket with handle by pushing the button located on the center of the face of the dispenser down and pulling it down and out towards you.

TROUBLESHOOTING

Problem	Solution
Ice cream is not ready in recommended time.	Check recipe to make sure that the ingredients are correct. Keep the freezer bowl in the freezer for a longer amount of time before making ice cream. Do not let freezer bowl sit outside of the freezer for more than 5 minutes before making ice cream. Make sure your freezer is set to 0°F.
Ice cream is not dispensing.	The ice cream may be too thick. Check the processing time. Check recipe to make sure that the ingredients are correct. Remove the bowl, scoop out and eat the ice cream.
Motor stalls.	The ice cream may be too thick. Check the processing time. Turn off ice cream maker. Clean ice cream maker and put freezer bowl in the freezer. Make a new batch once the bowl is frozen for the recommended amount of time.
Mix-ins are not dispensing.	Check the condiment chute to make sure that mix-ins are not stuck. Clean and dry the chute. Check mix-ins to make sure that they are not melting. Clean and dry condiment dispensers. Check for jammed mix-ins. Mix-ins may be too large.
The mixing arm is not turning.	Check to make sure there is no ice in the freezer bowl. Check to see if unit is on. The ice cream may be too thick.

CLEANING

1. Unplug your Cuisinart® Mix It In™ Soft Serve Ice Cream Maker before cleaning.

2. Base: Wipe with a damp cloth and dry.

Never use abrasives or immerse in water.

3. Freezer Bowl and Lid: Wash by hand in warm soapy water and dry thoroughly. DO NOT PUT IN THE DISHWASHER. DO NOT CLEAN WITH ABRASIVE CLEANSERS OR IMPLEMENTS.

4. Handle with Dispensing Bracket: Wash thoroughly by hand in warm soapy water. Be sure to eliminate all ice cream residue by cleaning the dispensing while it is opened (with the handle pushed down) and closed (with handle up).

5. Mixing Arm, Condiment Containers, Condiment Chute and Drip Tray: Wash by hand in warm soapy water and dry thoroughly. These parts are also top rack dishwasher-safe. Be careful not to remove the small rubber pads that are located inside the condiment containers when cleaning. The rubber pads are a part of the condiment containers and are not removable.

STORAGE

DO NOT put freezer bowl in freezer if bowl is wet. DO NOT store lid, mixing arm, base, drip tray or condiment containers in the freezer.

You may store the freezer bowl in the freezer, in its upright position, for convenient, immediate use. Before freezing, wrap the bowl in a plastic bag to prevent freezer burn. Do not store frozen desserts in the freezer bowl. Transfer desserts to an airtight container for longer storage in the freezer.

When filled condiment containers are not in use, store in a cool, dark place. Empty containers if not used once a week. Start with fresh mix-ins so they don't spoil.

NOTE: The ice cream will lose its soft consistency and harden after it is stored in the freezer.

IMPORTANT SAFEGUARDS

When using an electrical appliance, basic safety precautions should always be followed to reduce the risk of fire, electric shock, and/ or injury, including the following:

1. READ ALL INSTRUCTIONS BEFORE USING.
2. To protect against risk of electric shock, do not place cord, plug, or base of appliance in water or any other liquid.
3. Close supervision is necessary when any appliance is used by or near children.
4. Always unplug appliance from outlet when not in use, before putting on or taking off parts, and before cleaning.
5. Avoid contact with moving parts. Keep hands, hair, clothing, as well as spatulas and other utensils away from appliance during operation to reduce the risk of injury and/or damage to the appliance.

6. Do not operate any appliance with a damaged cord or plug, or after the appliance malfunctions, or is dropped or damaged in any manner. Return the appliance to the nearest Cuisinart Repair Center for examination, repair, electrical or mechanical adjustment.
7. The use of attachments other than those made by Cuisinart may cause fire, electric shock or risk of injuries.
8. Do not use outdoors.
9. Do not let cord hang over edge of table or counter, or touch hot surfaces.
10. Keep hands and utensils out of freezer bowl while in use to reduce the risk of injury to persons or to the appliance itself. **DO NOT USE SHARP OBJECTS OR UTENSILS INSIDE THE FREEZER BOWL!** Sharp objects will scratch and damage the inside of the freezer bowl. A rubber spatula or wooden spoon may be used when the appliance is in the OFF position.
11. This appliance is for household use. Any servicing other than cleaning and user maintenance should be done only by authorized Cuisinart Repair Personnel.
12. Do not use the freezer bowl on flames, hot plates or stoves. Do not expose to heat source. Do not wash in dish washer; doing so may cause risk of fire, electric shock or injury

Warning

This content is compiled from multiple sources and is provided for reference purposes only. It may not be complete or fully applicable to all situations. If you are unable to resolve your issue, please contact the product manufacturer or an authorized service provider for official support.