







Instrument Panel

Indicators

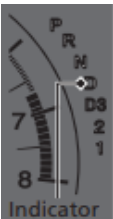

Indicator	Name	On/Blinking	Explanation	Message
	<p>Malfunction Indicator Lamp</p>	<p>Comes on when you turn the ignition switch to ON , and goes off either when the engine starts or after several seconds if the engine did not start. If "readiness codes" have not been set, it blinks five times before it goes off.</p> <p>Comes on if there is a problem with the emissions control system.</p> <p>Comes on if there is a problem with the fuel system.</p> <p>Blinks when a misfire in the engine's cylinders is detected.</p>	<p>Readiness codes are part of the on board diagnostics for the emissions control systems.</p> <p>Comes on while driving - Have your vehicle checked by an authorized Honda Civic Natural Gas dealer as soon as possible.</p> <p>Blinks while driving - Stop in a safe place where there are no flammable objects. Stop the engine for 10 minutes or more, and wait for it to cool down. Then, take the vehicle to a dealer</p>	
	<p>Shift Lever Position Indicator</p>	<p>Indicates the current shift lever position.</p>	<p>Shifting section</p>	
				

Indicator	Name	On/Blinking	Explanation	Message
	Low Fuel Indicator	<p>Comes on when you turn the ignition switch to ON , and goes off when the engine starts.</p> <p>Comes on when the fuel reserve is running low.</p> <p>Blinks if there is a problem with the fuel gauge.</p>	<p>Comes on - Refuel your vehicle as soon as possible.</p> <p>When the outside air gets very cold [below 25°F (- 4°C)], the pressure of the natural gas inside the tank goes down, and the fuel gauge may indicate that you have less fuel than what actually remains in the tank. Keep this in mind if the low fuel indicator comes on while you are driving in cold weather.</p> <p>Blinks - Have your vehicle checked by an authorized Civic Natural Gas dealer as soon as possible.</p>	

intelligent Multi-Information Display (i-MID) Warning and Information Messages

The following messages appear only on the i-MID. Press the  (display/information) button to see the message again with the system message indicator on.

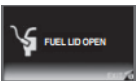
Message	Condition	Explanation
	Appears when the fuel receptacle lid is open.	Fuel Gauge section

Gauges and Displays

Gauges

Fuel Gauge

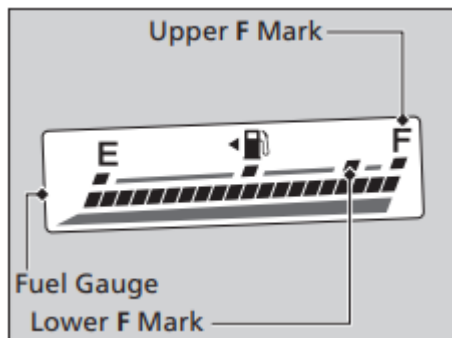

Displays the amount of fuel left in the fuel tank.

The lower F mark indicates a full tank at a fill pressure of 3,000 psi.

The upper F mark indicates a full tank at a fill pressure of 3,600 psi.



If the fuel receptacle lid is open, the fuel gauge blinks when you turn the ignition switch to ON 

It stops blinking when you close the lid.

NOTE:

- The quantity of fuel remaining in the tank is calculated based on the pressure and temperature of the natural gas in the fuel tank.
- The gauge, average fuel, range, and instant fuel economy show more or less than the actual amount. The tank temperature, fill method, and ambient conditions may affect the pressure and temperature of the natural gas.
- You can choose when to reset the average fuel economy.
- Refueling a small amount of gas may not trigger trip FUEL LID OPEN A and the average fuel economy to reset.

Driving

Before Driving

Storing Cargo in the Trunk

Do not put large, heavy or pointed objects in the trunk. When storing items, properly secure them so that they do not move around while driving. The fuel tank is located in the trunk, and although a partition separates the tank from the cargo space, large items or loose items can damage the fuel tank and fuel system components.

Towing a Trailer

Your vehicle is not designed to tow a trailer. Attempting to do so can void your warranties.

When Driving

Starting the Engine

1. Make sure the parking brake is applied.



2. Check that the shift lever is in **P**, then depress the brake pedal.

Although it is possible to start the vehicle in **N**, it is safer to start it in **P**.

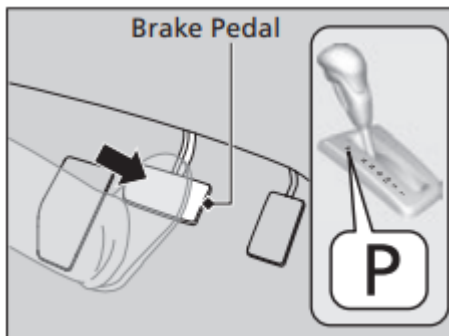

NOTE:

- Keep your foot firmly on the brake pedal when starting the engine.
- The engine is harder to start in cold weather and in thinner air found at altitudes above 8,000 feet (2,400 meters).

- When starting the engine in cold weather, turn off all electrical accessories (the lights, heating and cooling system, and rear defogger) in order to reduce battery drain.
- If you live in a region where winter is extremely cold, an engine block heater will improve starting and warming of the engine. If temperatures consistently below -22°F (-30°C) are expected, the coolant mixture should be changed to a higher concentration to prevent freezing. Consult a dealer for details.
- If the exhaust system sounds abnormal or you can smell exhaust gas inside the vehicle, have your vehicle checked by a dealer. There may be a problem with the engine or exhaust system.

3. Turn the ignition switch to ON  without depressing the accelerator pedal.

You may hear a click from the in-tank fuel shut-off valve.

4. Turn the ignition switch to START  without depressing the accelerator pedal.

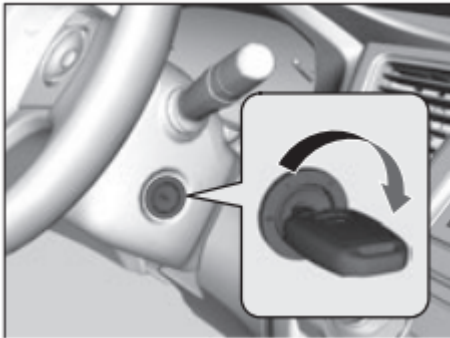

NOTE:

Do not hold the key in START III for more than 15 seconds.

- If the engine does not start right away, wait for at least 10 seconds before trying again.
- If the engine starts, but then immediately stops, wait at least 10 seconds before repeating step 4 while gently depressing the accelerator pedal. Release the accelerator pedal once the engine starts.

The immobilizer system protects your vehicle from theft. If an improperly coded key (or other device) is used, the engine's fuel system is disabled.

After extended storage: If you ever parked your vehicle for an extended period, open the trunk for several minutes before starting the engine to allow any natural gas vapors that may have accumulated to dissipate.

Automatic Transmission

Creeping

The engine runs at a higher idle speed and creeping increases. Keep the brake pedal firmly depressed when stopped.



Kickdown

Quickly depressing the accelerator pedal while driving uphill may cause the transmission to drop to a lower gear, unexpectedly increasing vehicle speed. Depress the accelerator pedal carefully, especially on slippery roads and curves.

Shifting

Change the shift position in accordance with your driving needs.

Shift lever positions

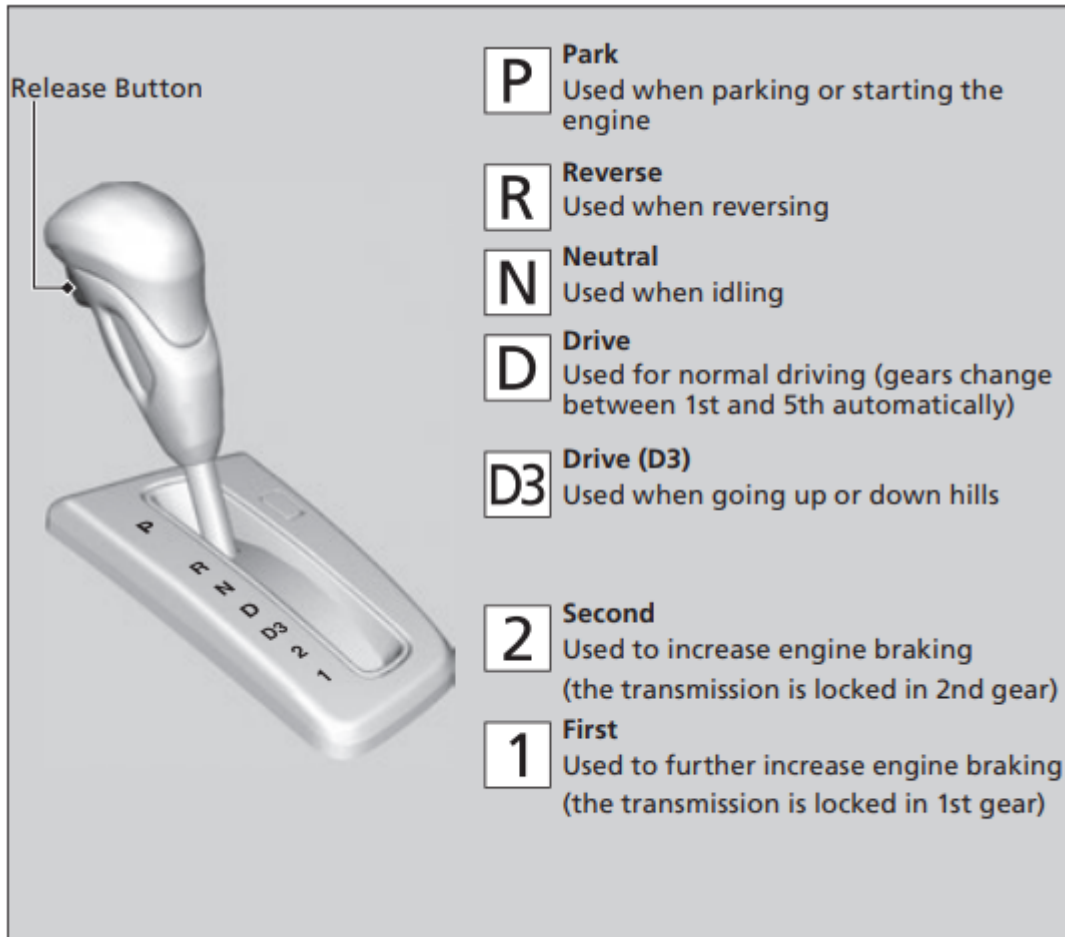

You cannot turn the ignition switch to LOCK **0** and remove the key unless the shift lever is in **P**.

The vehicle may move forward very slightly even in **N** while the engine is cold.

Depress the brake pedal firmly and, when necessary, apply the parking brake.

Shift Lever Operation

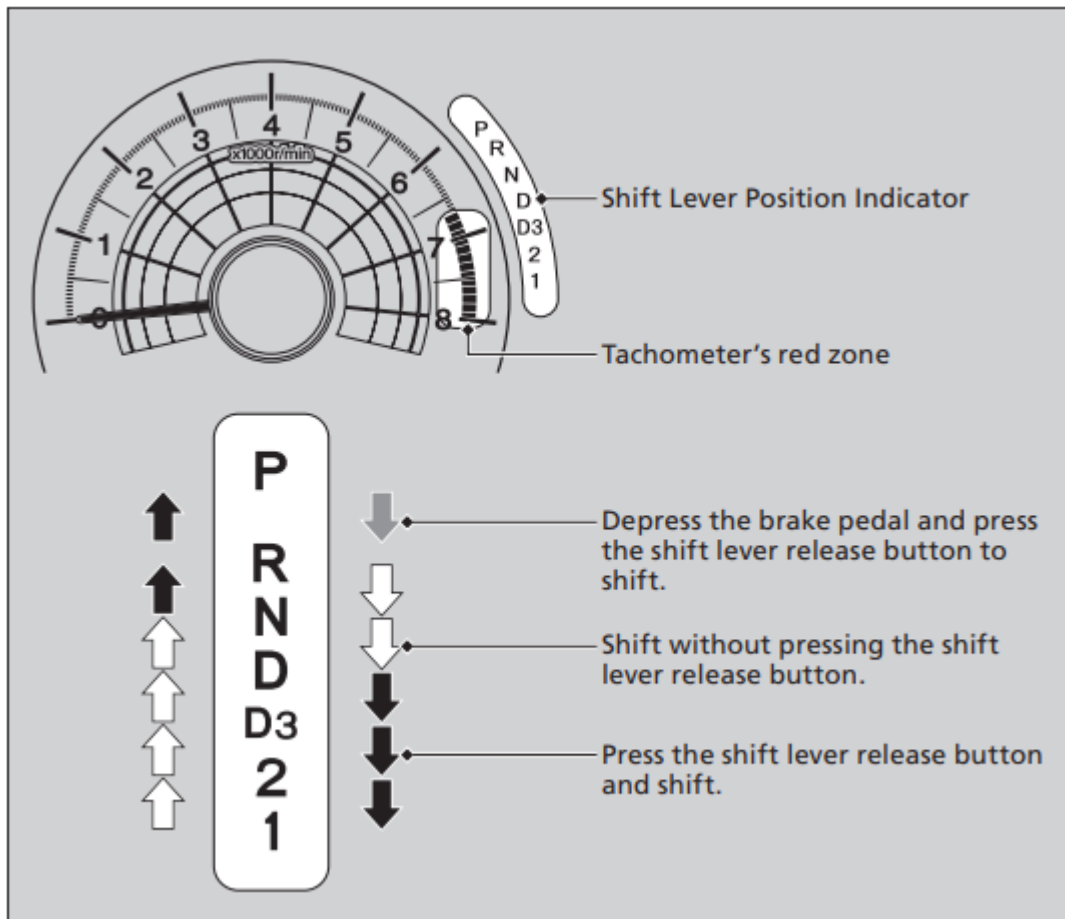

NOTICE:

- When you change the shift lever from **D** to **R** and vice versa, come to a complete stop and keep the brake pedal depressed.
- Operating the shift lever before the vehicle has come to a complete standstill can damage the transmission.
- Use the shift lever position indicator to check the lever position before pulling away.
- Whichever position the shift lever is in when driving, a blinking **D** indicator indicates a transmission problem.
- Avoid sudden acceleration and have the transmission checked by a dealer as soon as possible.
- The fuel supply may be cut off if you drive at engine speeds in or over the tachometer's red zone (engine speed limit). If this happens, you may experience a slight jolt.
- It may not be possible to operate the shift lever if the brake pedal is applied while the shift lever release button is held down.
- Depress the brake pedal first.

Refueling

Fuel Information



Only fuels that can be used

NFPA-52 and SAE J1616 standards

Use of a fuel that does not meet these standards can cause a decrease in engine power and damage the emission controls.

Fuel tank capacity:

Slow filling

6.96 gasoline gallon equivalent (3,000 psi)

7.77 gasoline gallon equivalent (3,600 psi)

Fast filling

5.84 gasoline gallon equivalent (3,000 psi)

6.51 gasoline gallon equivalent (3,600 psi)

NOTE: The location of the CNG pump can vary from station to station, may not be clearly marked, or be readily accessible during certain hours. It is recommended that you call the station (the number should be displayed with the address information) to verify the location and availability of the CNG pump before you arrive.

How to Refuel

WARNING:

- Compressed natural gas is flammable and highly explosive. You could be killed or seriously injured if leaking natural gas is ignited.
- If you suspect a leak, have your vehicle immediately inspected and repaired by an authorized Honda Civic Natural Gas dealer.

There are two methods of refueling:

Fast filling

It takes about three to five minutes to fill up the fuel tank. This method is usually available at stations designed to refuel natural gas vehicles.

During fast filling, the natural gas is warmed, causing the pressure in the tank to rise and reduces the amount of fuel you can put in.

Slow filling

It takes about an hour and a half per GGE (Gasoline Gallon Equivalent) to fill up the fuel tank. This method can be done using a vehicle refueling appliance.

Refueling Procedure Example

1. Stop your vehicle with the service station pump on the left side of the vehicle in the rear.

2. Turn off the engine.

3. Push on the fuel receptacle lid release handle at the foot of the driver's seat.

The fuel receptacle lid opens.

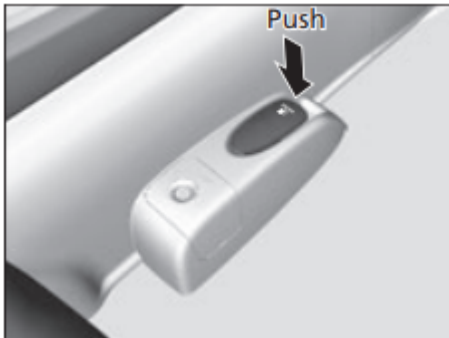

4. Remove the receptacle dust cap from the fuel receptacle.

Clean off any dirt or debris around the fuel receptacle.

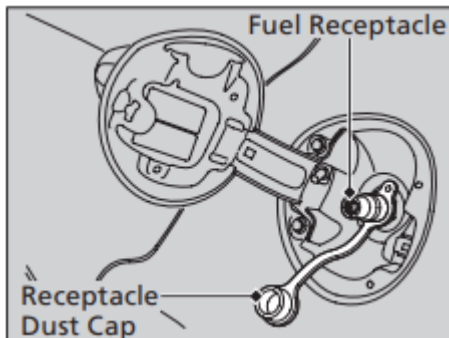

5. Securely connect the CNG fill nozzle to the fuel receptacle.

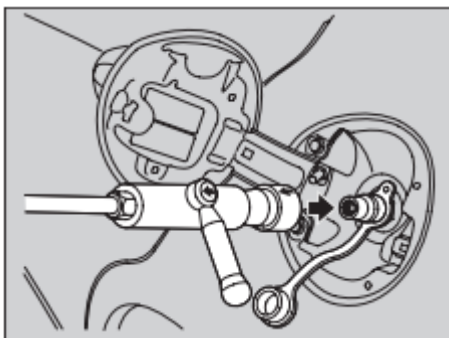

6. Turn the lever until the arrows on the nozzle point to each other, then follow the instructions on the refueling station to begin refueling.

While refueling, you may hear a chattering sound. This is normal.

7. Refueling will stop automatically when the tank is full. Follow the instructions on the refueling station to turn it off.

8. Disconnect the CNG fill nozzle from the fuel receptacle by slowly turning the lever on the nozzle 180 degrees.

You may hear a brief hissing sound as a small amount of gas escapes, and may detect a slight gas odor. This is normal.

9. After filling, replace the receptacle dust cap on the fuel receptacle securely.

Shut the fuel receptacle lid by hand.

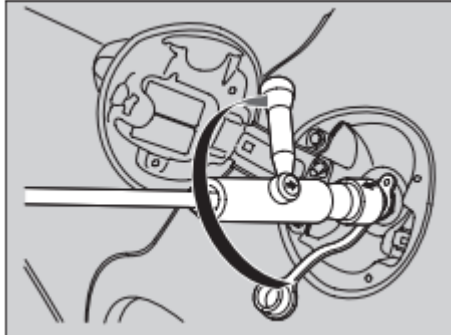

NOTICE:

- Using fast fill equipment at temperature below -4°F (-20°C) may damage the fuel system, potentially causing a leak.
- Always observe all safety recommendations and operating instructions on the refueling equipment.
- Use a fuel filler nozzle that complies with ANSI/AGA NGV-1-2008 standards.
- The CNG filler nozzle mechanism may vary by service station. Each nozzle standard has different maximum pressure:

P24 – 2,400 psi (16,500 kPa)

P30 – 3,000 psi (20,700 kPa)

P36 – 3,600 psi (24,800 kPa)

- The refueling steps shown in this manual are the typical fast fill refueling procedure. You may need to go through different steps at a station with slow fill equipment or other types of equipment. Always follow the instructions provided on site.
- If you hear or see fuel/vapor leaking from the nozzle-receptacle connection, stop refueling immediately. Turn off the refueling station, remove the nozzle, reconnect it to the receptacle, and begin refueling again. Dirt or debris adhered to the inside of the fuel receptacle can cause a gas leak. Remove dirt or debris from the CNG filler nozzle with a clean, dry rag.
- If it continues to leak, have an authorized CNG dealer inspect the sealing O-ring in the fuel receptacle. It may be missing, damaged, or worn.
- If you are not sure how to operate the refueling station, ask for assistance.

Maintenance

Maintaining the Fuel System

Your vehicle's fuel system must be maintained and repaired by an authorized Civic Natural Gas dealer or a certified NGV technician. The fuel system has no user serviceable parts, and its components must not be modified.

See instructions on fuel container for inspection and service life

Service Pressure: 3,600 psi (24,800 kPa)

Indoor Vehicle Storage

If you store your vehicle indoors, make sure there is adequate ventilation. We recommend that you also install a natural gas leak detector.

WARNING:

- Tampering with, or improperly maintaining the high-pressure fuel system can cause a dangerous condition in which you can be seriously hurt or killed.
- Never attempt to modify the fuel system, and always have fuel system maintenance performed by an authorized Honda Civic Natural Gas dealer, or a qualified NGV technician.

Maintenance Minder

Your vehicle displays engine oil life and maintenance service items on the intelligent multi-information display (i-MID) to show you when you should have a dealer do engine oil replacement and indicated maintenance service.

Maintenance Service Items

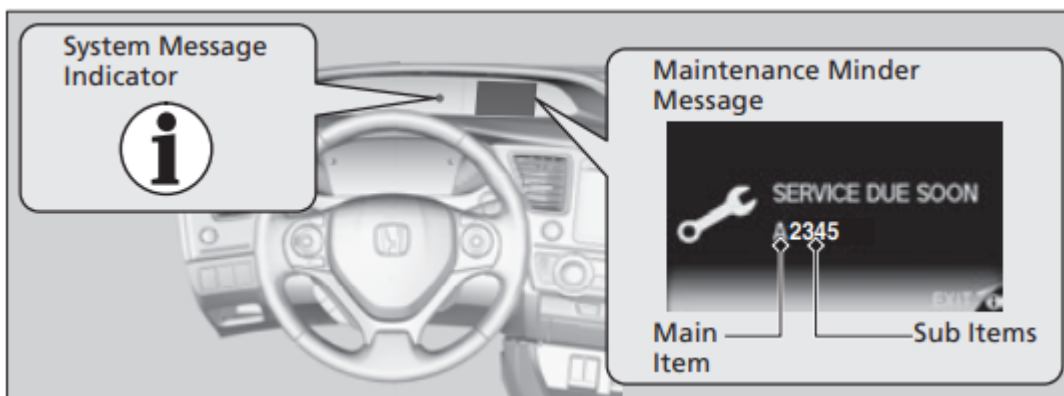

- Independent of the Maintenance Minder information, replace the brake fluid every 3 years.
- Inspect idle speed every 160,000 miles (256,000 km).
- Adjust the valves during services A, B, 1, 2, or 3 if they are noisy.

CODE	Maintenance Main Items
A	Replace engine oil *1
B	Replace engine oil *1 and oil filter Replace fuel filter element (low pressure) Drain fuel filter (high pressure) Inspect front and rear brakes/service as necessary Check parking brake adjustment Inspect tie rod ends, steering gearbox, and boots Inspect suspension components Inspect driveshaft boots Inspect brake hoses and lines (Including ABS/VSA) Inspect all fluid levels and condition of fluids Inspect exhaust system # Inspect fuel lines and connections # Check the expiration date for TRK bottle*2

*1: If a message SERVICE does not appear more than 12 months after the display is reset, change the engine oil every year.

*2: Models with tire repair kit

#: See information on maintenance and emissions warranty.



CODE	Maintenance Sub Items
1	Rotate tires
2	Replace air cleaner element *3 Replace dust and pollen filter *4 Replace fuel filter element (high pressure) Inspect drive belt Inspect valve clearance Inspect fuel tank *5
3	Replace transmission fluid
4	Replace spark plugs
5	Replace engine coolant

*3: If you drive in dusty conditions, replace the air cleaner element every 15,000 miles (24,000 km).

*4: If you drive primarily in urban areas that have high concentrations of soot in the air from industry and from diesel-powered vehicles, replace the dust and pollen filter every 15,000 miles (24,000 km).

*5: If sub item 2 does not appear more than 36 months after the display is reset, inspect the fuel tank every three years

Maintenance Under the Hood

Transmission Fluid

Automatic Transmission Fluid

Specified fluid: Honda ATF DW-1 (automatic transmission fluid)

Check the fluid level when the engine is at normal operating temperature.

1. Park on level ground, and start the engine.
2. Wait until the radiator fan starts and then turn off the engine.

Perform step 3 after waiting for about 60 seconds (less than 90 seconds).

3. Remove the dipstick (yellow loop) from the transmission and wipe it with a clean cloth.
4. Insert the dipstick all the way back into the transmission securely, as shown in the image.
5. Remove the dipstick and check the fluid level.

It should be between the upper and lower marks in the HOT range.

6. If the level is below the lower mark, add fluid into the dipstick hole to bring it to the level between the upper and lower marks, and have your vehicle checked by a dealer immediately

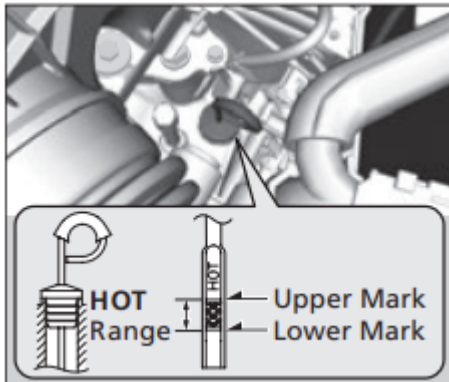

NOTICE:

- Do not mix Honda ATF DW-1 with other transmission fluids.
- Using a transmission fluid other than Honda ATF DW-1 may adversely affect the operation and durability of your vehicle's transmission, and damage the transmission.
- Any damage caused by using a transmission fluid that is not equivalent to Honda ATF DW-1 is not covered by Honda's new vehicle warranty.
- Pour the fluid slowly and carefully so you do not spill any. Clean up any spills immediately; they can damage components in the engine compartment.

Replacing Light Bulbs

High-Mount Brake Light Bulb

When replacing, use the following bulb.

High-Mount Brake Light: 21W

1. Open the trunk.
2. Remove the screw from the center of each trunk lining fastener, then remove the fasteners.

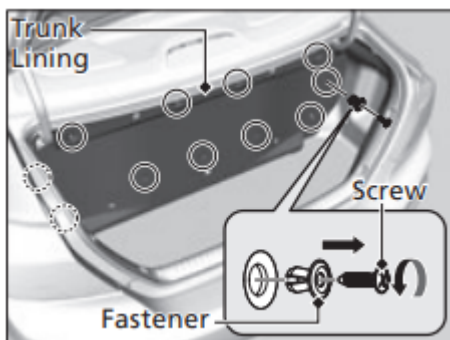

3. Pull the upper edge of the trunk lining down.



4. Turn the socket to the left and remove it.
5. Remove the old bulb and insert a new bulb.

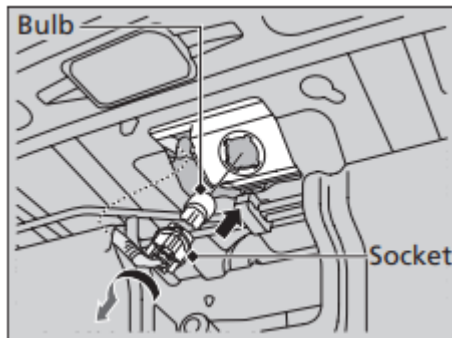

Handling the Unexpected

Tools

Type of Tools

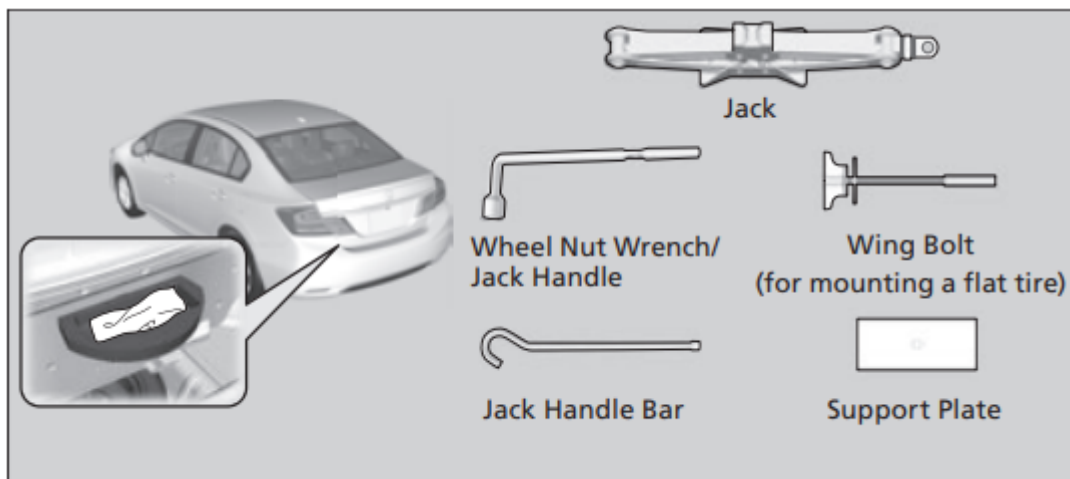

The tools are stored in the trunk.

If a Tire Goes Flat

Changing a Flat Tire

To change a flat tire, follow the instructions in the Owner's Manual. To remove the spare tire, tools and the jack from the trunk and to store the flat tire, follow the instructions in this section.

Removing the Spare Tire, Tools and the Jack

1. Open the trunk.
2. Remove the trunk floor lid

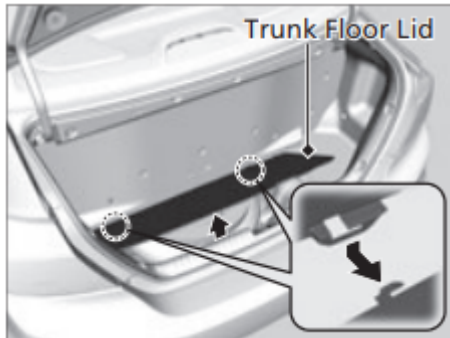

3. Take the tool case out of the spare tire.

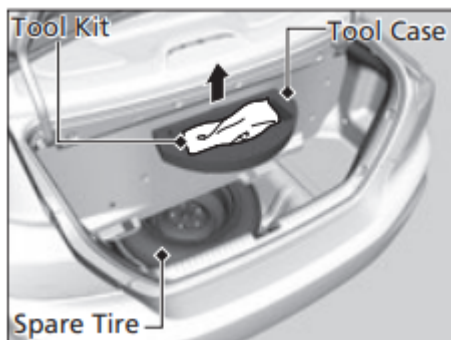

4. Unscrew the wing bolt and remove the spacer cone.

5. Take the spare tire out of its well.

Bend the lower part of the trunk lining upward to enlarge the opening.

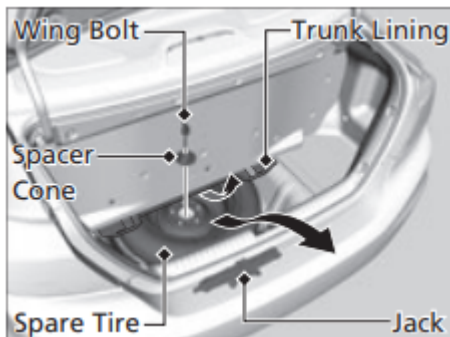

6. Turn the jack's end counterclockwise to loosen it, then remove the jack.

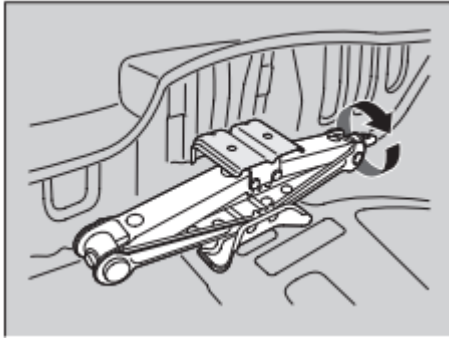

Storing a Flat Tire

1. Open the trunk.
2. Raise the trunk floor and the lower part of the trunk lining.
3. Remove the rubber caps from the holes in the trunk floor and the trunk lining, then align both holes.

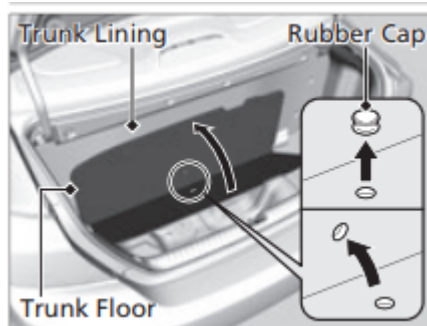

4. Place the flat tire straight up in the trunk, with the outside of the wheel facing forward.
5. Take the support plate and the wing bolt out of the tool kit. Put the plate on the wing bolt.
6. Insert the wing bolt through the hole in the center of the wheel and the trunk lining, then tighten the bolt.
7. Store the spacer cone and the spare tire wing bolt in the tool kit.

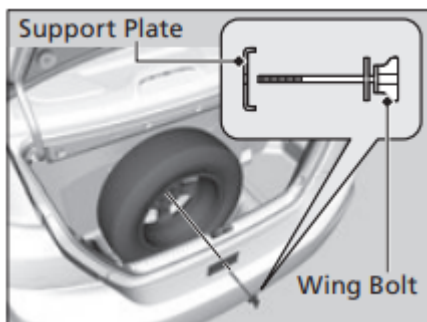

WARNING: Loose items can fly around the interior in a crash and can seriously injure the occupants. Store the wheel, jack, and tools securely before driving.

Temporarily Repairing a Flat Tire

This vehicle is not equipped with a spare tire. If the tire has a large cut or is otherwise severely damaged, you will need to have the vehicle towed. If the tire only has a small puncture, from a nail for instance, you can use the temporary tire repair kit so that you can drive to the nearest service station for a more permanent repair.

If a tire goes flat while driving, grasp the steering wheel firmly, and brake gradually to reduce speed. Then stop in a safe place.

1. Park the vehicle on firm, level, and non-slippery surface and apply the parking brake.
2. Put the shift lever in **P**.
3. Turn on the hazard warning lights and turn the ignition switch to LOCK **0**. When towing a trailer, unhitch the trailer

The kit should not be used in the following situations. Instead, contact a dealer or a roadside assistant to have the vehicle towed.

- The tire sealant has expired.
- More than two tires are punctured.
- The puncture or cut is larger than 3/16 inch (4 mm).
- The tire side wall is damaged or the puncture is outside the tire contact area.

	When the puncture is:	Kit Use
	Smaller than 3/16 inch (4 mm)	Yes
	Larger than 3/16 inch (4 mm)	No

- Damage has been caused by driving with the tire extremely under inflated.
- The tire bead is no longer seated.
- The rim is damaged.

Do not remove a nail or screw that punctured the tire. If you remove it from the tire, you may not be able to repair the puncture using the kit.

Getting Ready to Temporarily Repair the Flat Tire



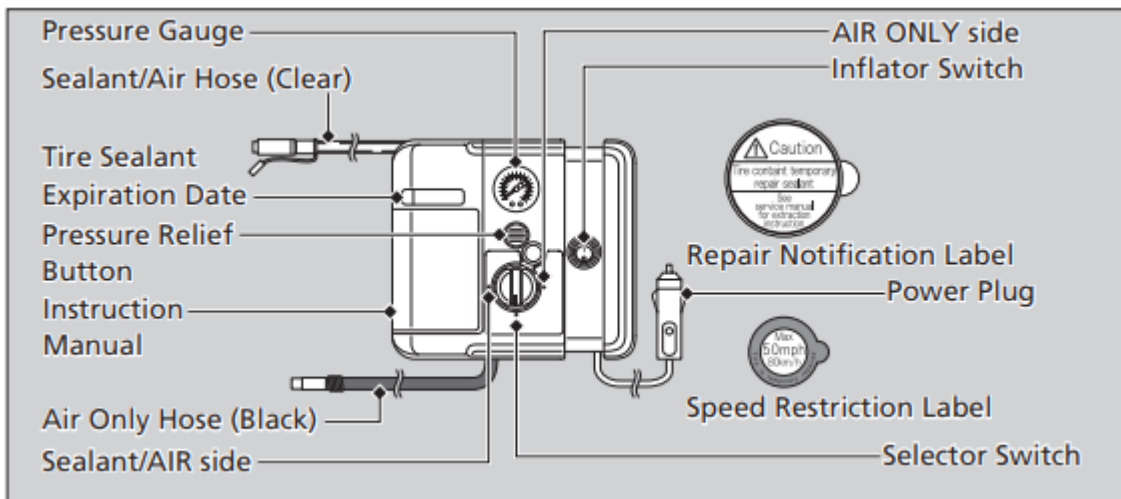

1. Remove the trunk floor lid.



2. Take the kit out of the case.

Place the kit face up, on flat ground near the flat tire, and away from traffic. Do not place the kit on its side.

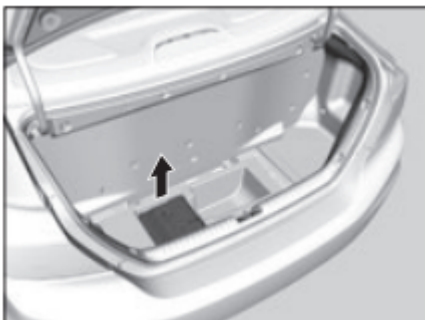

When making a temporary repair, carefully read the instruction manual provided with the kit.

In cold temperatures, the sealant may not flow easily. In this situation, warm it up for five minutes before using

Injecting Sealant and Air

1. Remove the valve cap from the tire valve stem.

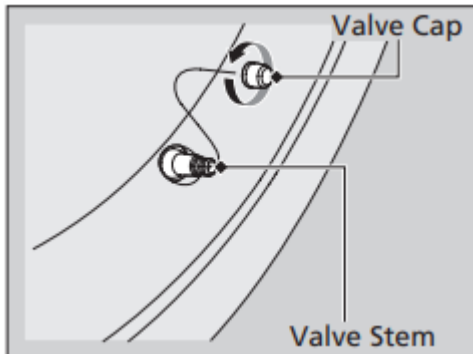

2. Remove the sealant/air hose from the packaging.

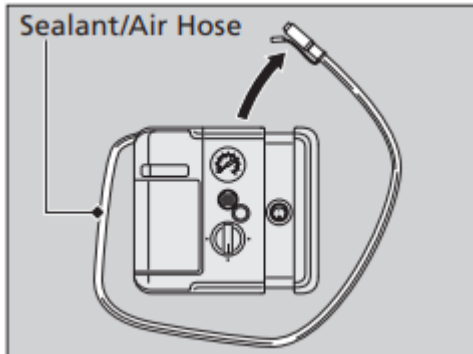

3. Attach the sealant/air hose onto the tire valve stem. Screw it until it is tight.

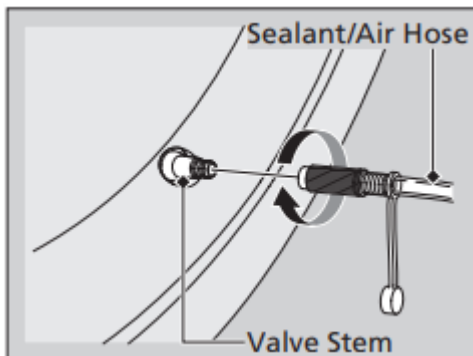

WARNING:

- Tire sealant contains substances that are harmful and can be fatal if swallowed.
- If accidentally swallowed, do not induce vomiting. Drink plenty of water and get medical attention immediately. For skin or eye contact, flush with cool water and get medical attention if necessary.

In cold temperatures, the sealant may not flow easily. In this situation, warm it up for five minutes before using.

The sealant can permanently stain clothing and other materials. Be careful during handling and wipe away any spills immediately

4. Plug in the compressor to the accessory power socket.

Be careful not to pinch the cord in a door or window.

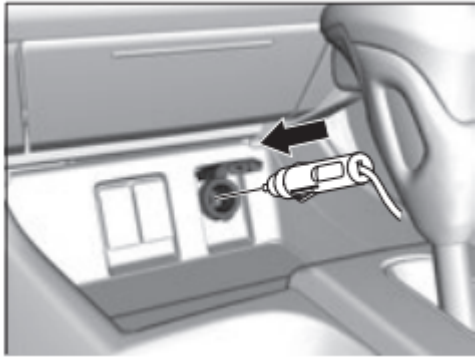

5. Start the engine.

Keep the engine running while injecting sealant and air.

6. Turn the selector switch to SEALANT/AIR.

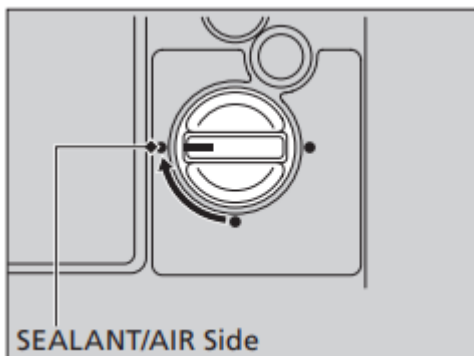

7. Press the inflator switch to turn on the compressor.

The compressor starts injecting sealant and air into the tire.

8. When the sealant injection is complete, continue to add air.

9. After the air pressure reaches 30 psi (210 kPa), turn off the kit.

To check the pressure, occasionally turn off the compressor and read the gauge.

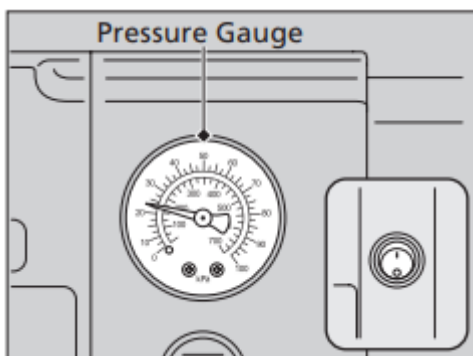

WARNING:

- Running the engine with the vehicle in an enclosed or even partly enclosed area can cause a rapid build-up of toxic carbon monoxide.

- Breathing this colorless, odorless gas can cause unconsciousness and even death. Only run the engine to power the air compressor with the vehicle outdoors.

NOTICE:

- Do not operate the tire repair kit compressor for more than 15 minutes. The accessory power socket and compressor can overheat and become permanently damaged.
- Until the sealant injection is complete, the pressure shown on the pressure gauge will appear higher than actual. After the sealant injection is complete the pressure will drop and then begin to rise again as the tire is inflated with air. This is normal. To accurately measure the air pressure using the gauge, turn the air compressor off only after the sealant injection is complete.
- If the required air pressure is not reached within 10 minutes, the tire may be too severely damaged for the kit to provide the necessary seal and your vehicle will need to be towed.

10. Unplug the power plug from the accessory power socket.

11. Unscrew the sealant/air hose from the tire valve stem. Reinstall the valve cap.

12. Press the pressure relief button until the gauge returns 0 psi (0 kPa).

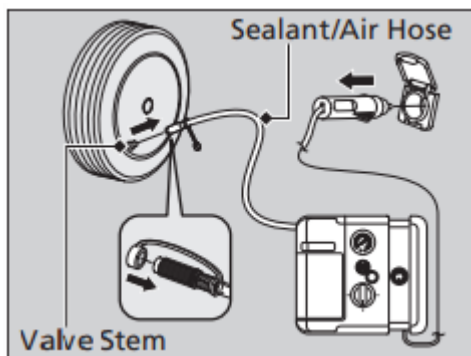

13. Apply the repair notification label to the flat surface of the wheel.

The wheel surface must be clean to ensure the label adheres properly

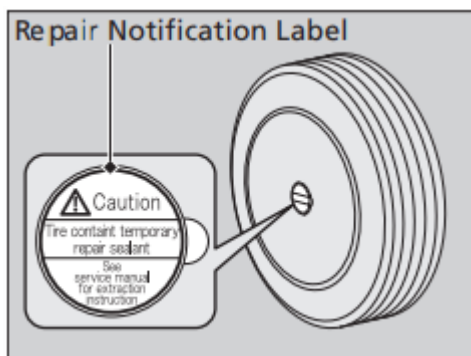

See a Honda dealer for a replacement sealant bottle and proper disposal of an empty bottle.

Distributing the Sealant in the Tire

1. Apply the speed restriction label to the location as shown.
2. Drive the vehicle for about 10 minutes.

Do not exceed 50 mph (80 km/h).

3. Stop the vehicle in a safe place.

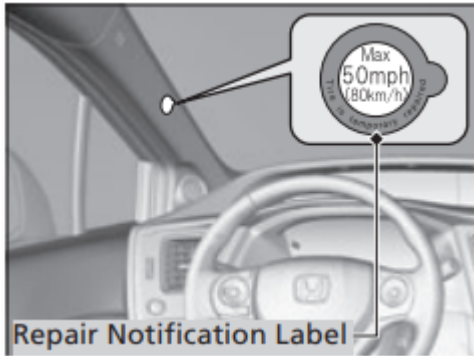

Stop and recheck the air pressure after every 10 minutes of driving as necessary until you reach the nearest service station where you are able to have the tire permanently repaired or replaced.

4. Attach the air only hose onto the tire valve stem. Screw it until it is tight.
5. Turn the selector switch to AIR ONLY. Do not turn the air compressor on to check the pressure.

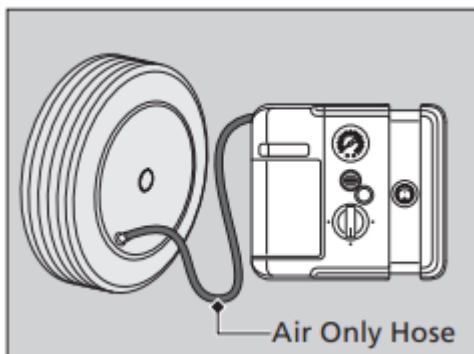

6. If the air pressure is:

- Less than 19 psi (130 kPa):

Do not add air or continue driving. The leak is too severe. Call for help and have your vehicle towed.

- 30 psi (210 kPa) or more:

Continue driving for another 10 minutes or until you reach the nearest service station. Do not exceed 50 mph (80 km/h).

If the air does not go down after the 10 minute drive, you do not need to check the pressure any more.

- Greater than 19 psi (130 kPa), but less than 30 psi (210 kPa):

Turn the air compressor on to inflate the tire until the tire pressure reaches 30 psi (210 kPa).

Then drive carefully for 10 more minutes or until you reach the nearest service station. Do not exceed 50 mph (80 km/h).

You should repeat this procedure as long as the air pressure is within this range.

7. Press the pressure relief button until the gauge returns to 0 psi (0 kPa).

8. Repackage and properly stow the kit.

WARNING:

- Running the engine with the vehicle in an enclosed or even partly enclosed area can cause a rapid build-up of toxic carbon monoxide.
- Breathing this colorless, odorless gas can cause unconsciousness and even death. Only run the engine to power the air compressor with the vehicle outdoors.

Inflating An Under-inflated Tire

You can use the kit to inflate a non-punctured under-inflated tire.

1. Remove the trunk floor lid.
2. Remove the kit from the case.

Place the kit on flat ground near the tire to be inflated, away from traffic.

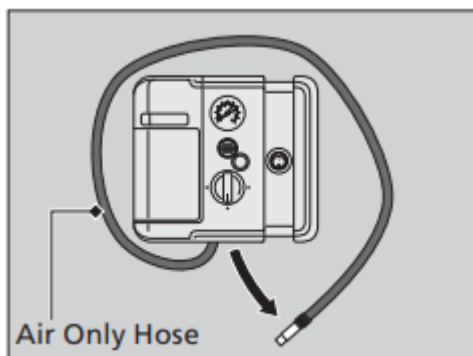

3. Place the kit, face up, on flat ground near the flat tire, away from traffic. Do not place the kit on its side.
4. Remove the air only hose from the kit.
5. Remove the valve cap.



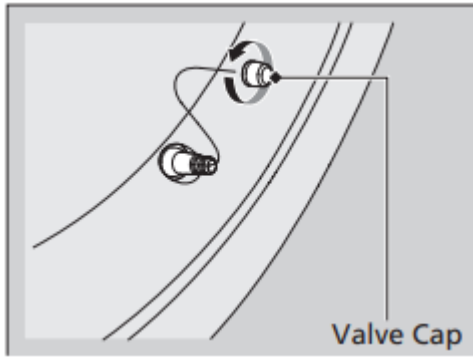

6. Attach the air only hose onto the tire valve stem. Screw it until it is tight.

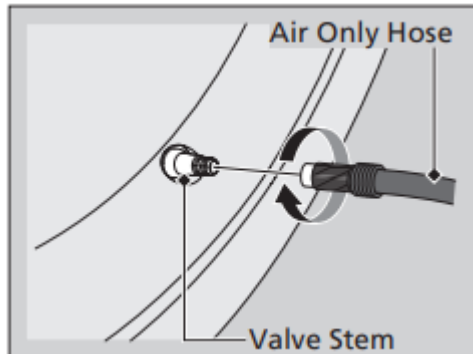

NOTICE: Do not operate the temporary tire repair kit compressor for more than 15 minutes. The accessory power socket and compressor can overheat and become permanently damaged.

7. Plug in the kit to the accessory power socket.

Be careful not to pinch the cord in a door or window.

8. Start the engine.

Keep the engine running while injecting air.

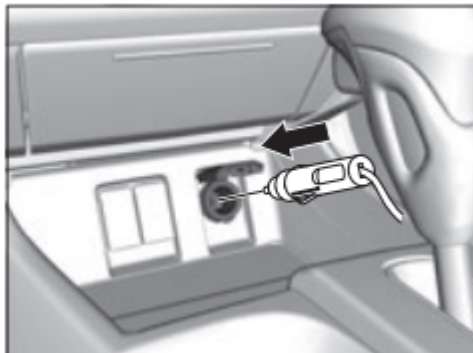

9. Turn the selector switch to AIR ONLY.

10. Press the inflator switch to turn on the kit.

The compressor starts to inject air into the tire.

11. Inflate the tire to the specified air pressure.

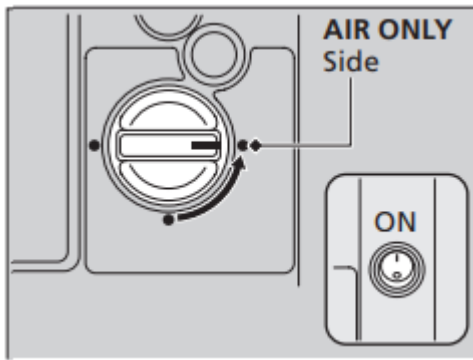

12. Turn off the kit.

Check the pressure gauge on the air compressor.

If overinflated, press the pressure relief button.

13. Unplug the kit from the accessory power socket.

14. Unscrew the air only hose from the tire valve stem. Reinstall the valve cap.

15. Press the pressure relief button until the gauge returns 0 psi (0 kPa).

16. Repackage and properly stow the kit

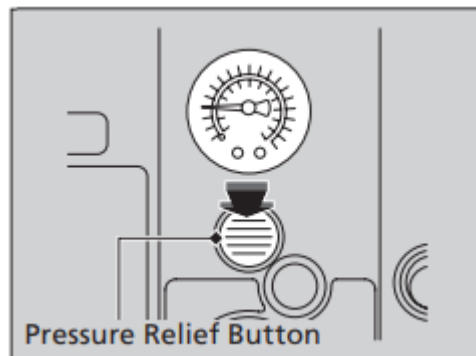

WARNING:

Running the engine with the vehicle in an enclosed or even partly enclosed area can cause a rapid build-up of toxic carbon monoxide.

Breathing this colorless, odorless gas can cause unconsciousness and even death. Only run the engine to power the air compressor with the vehicle outdoors.

Fuel Leaks

If a Fuel Leak is Detected

If you smell natural gas or hear a hissing sound, except when refueling, the fuel system may have a leak.

WARNING:

- Compressed natural gas is flammable and highly explosive. You could be killed or seriously injured if leaking natural gas is ignited.



- If you suspect a leak, have your vehicle immediately inspected and repaired by an authorized Honda Civic Natural Gas dealer.

Do not jump start your vehicle if you suspect a gas leak.

Turning Off the Manual Shut-Off Valve

1. Park your vehicle outside in a well-ventilated area. Set the parking brake. Keep away from heat, sparks, and flame.
2. Open all the windows and trunk for ventilation.
3. Turn the ignition switch to LOCK 0 .

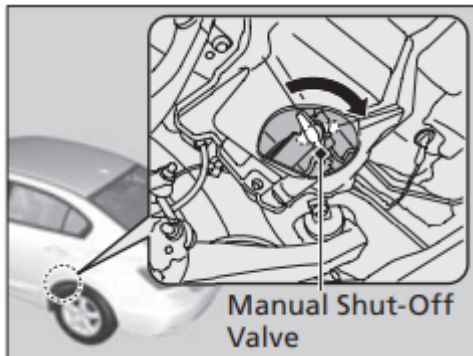

4. Turn the manual shut-off valve one-quarter turn clockwise (located as shown).

The valve is turned to OFF.

5. Call a professional towing service.

You cannot continue driving. Have the vehicle towed to an authorized Civic Natural Gas dealer.

We recommend that you locate the valve before driving so that you can turn it off quickly if necessary.

Turn off the valve if you ever suspect a fuel leak or are involved in an accident.

Turn the manual shut-off valve to OFF also when you are storing your vehicle for an extended period.

Indicator, Coming On/Blinking

If the Malfunction Indicator Lamp Comes On or Blinks

Reasons for the indicator lamp to come on or blink

- Comes on when there is a problem with the engine emissions control system, or the fuel system.
- Blinks when engine misfiring is detected.

What to do when the indicator lamp comes on

Avoid high speeds and immediately get your vehicle inspected at an authorized Civic Natural Gas dealer.

What to do when the indicator lamp blinks

Park the vehicle in a safe place with no flammable items and wait at least ten minutes or more with the engine stopped until it cools.

NOTICE:

- If you drive with the malfunction indicator lamp on, the emissions control system and the engine could be damaged.
- If the malfunction indicator lamp blinks again when restarting the engine, drive to the nearest dealer at 31 mph (50 km/h) or less for an inspection.

Warning

This content is compiled from multiple sources and is provided for reference purposes only. It may not be complete or fully applicable to all situations. If you are unable to resolve your issue, please contact the product manufacturer or an authorized service provider for official support.