

COOKING RECOMMENDATIONS

Bakeware

The material of bakeware affects how evenly and quickly it transfers heat from the pan to the food.

| Material | Attributes | Recommendation |
|----------------------|--|--|
| Shiny metal bakeware | Shiny, aluminum, and non-coated bakeware is the best for even heating. It is suitable for all baked goods. | Recommended cooking temperatures and times are based on shiny metal bakeware. |
| Dark metal bakeware | Dark bakeware cooks hotter than shiny bakeware. | Reduce the cooking temperature by 25° F (13-14° C) when using dark bakeware. |
| Glass bakeware | Glass bakeware cooks hotter than shiny bakeware. Glass is convenient, as the same piece of bakeware can be used for cooking, serving, and storing food. | Reduce the cooking temperature by 25° F (13-14° C) when using glass bakeware. |
| Insulated bakeware | Insulated bakeware cooks cooler than shiny bakeware. Insulated bakeware is designed for baking in gas ovens. | Insulated bakeware cooks cooler than shiny bakeware. Insulated bakeware is designed for baking in gas ovens. |

Cooking Conditions

Conditions in your kitchen can affect the performance of your appliance when cooking food.



| Condition | Attributes | Recommendation |
|-----------------------|---|--|
| Aging cookware | <ul style="list-style-type: none"> • As pans age and become discolored, cooking times may need to be reduced slightly | <ul style="list-style-type: none"> • If food is too dark or overcooked, use the minimum cook time in the recipe or packaging. • If food is too light or undercooked, use the middle to maximum cook time in the recipe or packaging. |
| High altitude | <ul style="list-style-type: none"> • Air is drier and air pressure is lower. • Water boils at a lower temperature, and liquids evaporate faster. • Foods may take longer to bake. • Doughs may rise faster. | <ul style="list-style-type: none"> • Adjust cooking temperature, cooking time, or recipes as needed. • Increase amount of liquid in baking recipes. • Increase cook time on cooktop. Cover dishes to reduce evaporation. Increase bake time or oven temperature. • Reduce amount of baking soda or baking powder in recipe. Reduce rising time or punch down dough and allow it to rise twice. |

Cooking Results

Small adjustments may fix a problem with food not being as done as you like or more done than you like.



| Result | Recommendation |
|-----------------------|---|
| Food too light | Use the middle to maximum cook time recommended on packaging or recipe. |
| Food too dark | Use the minimum cook time recommended on packaging or recipe. |

Cooking Tips

Use these additional tips to get the best results from your appliance.



| Cooking | Tips |
|--------------------------------|--|
| Baking | |
| Rack placement | <p>Follow the instructions in “Oven Control Features” on starting on page 17.</p> <p>When using only one rack, place the rack so the food is in the center of the oven.</p> |
| Preheat | <p>Fully preheat the oven before baking items like cookies, cakes, biscuits and breads immediately after the beep.</p> |
| Checking food | <p>Use the window and oven light when checking food. Opening the door may reduce performance.</p> |
| Bake or Convection Bake | <p>Convection bake is the best function to use for baking on multiple racks. For best performance see “Convection Bake” on page 22.</p> |
| Food placement | <p>Allow at least 2 inches (5 cm) of space between bakeware for proper air circulation.</p> |
| Broiling / Roasting | |
| Broiling pan | <p>For best results when broiling, use a broil pan with a broil pan insert designed to drain from the food, help avoid spatter, and reduce smoking. The broiler pan will catch grease and the insert helps prevent grease splatters.</p> <p>If a broiler pan and insert are not supplied with this appliance, they may be purchased at Frigid-aire.com.</p> |
| Convection Cooking | |
| Convection attributes | <p>Convection cooking uses a fan to circulate hot air around the oven and food. It browns evenly and reduces hot spots in the oven.</p> <p>Convection saves time when using multiple racks or cooking several food items at once.</p> |



| | |
|-------------------------|---|
| Convection bake | <p>Reduce cooking temperature by 25° F (13-14° C) from the recipe unless the recipe is specifically for convection baking.</p> <p>Preheat the oven for best results.</p> |
| Convection roast | <p>Convection roast is best for meats and does not require preheating for most meats and poultry.</p> <p>Reducing the cooking temperature for convection roast is not recommended. Carefully follow your recipe's temperature and time recommendations, adjusting the cooking time if the recipe does not specify convection roasting time.</p> <p>Since convection roast cooks faster, cook time may be reduced by 25% to 40% depending on the food type. You can reduce cook times by 25% from the recommended time of your recipe. Check the food at this time. If needed, continue cooking until the desired doneness is reached.</p> <p>Use a meat probe if available with your appliance. Meat probes are also available from grocery and home goods stores.</p> <p>Arrange oven racks so large cuts of meat and poultry are on the lowest rack of the oven.</p> <p>Do not cover foods when dry roasting - covering will prevent the meat from browning.</p> <p>When cooking meats, use the broiler pan and insert or a roasting rack. The broiler pan catches grease spills and the insert helps prevent grease splatters. If you do not have one of these accessories, they may be purchased from Frigidaire.com.</p> |

BEFORE SETTING SURFACE CONTROLS

Oven Vent Location

The oven is vented as shown below. When the oven is on, warm air is released through the vent. This venting is necessary for proper air circulation in the oven and good baking results. Do not block oven vent. Never close off the openings with aluminium foil or any other material. Steam or moisture may appear near the oven vent; this is normal.

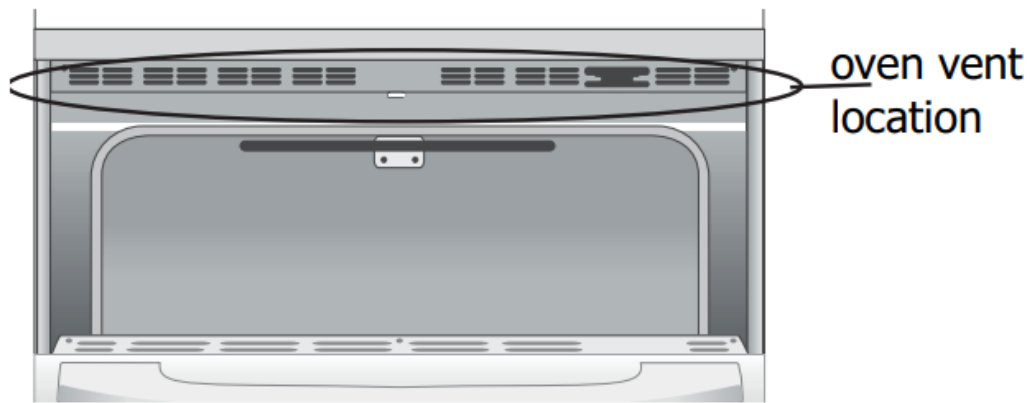
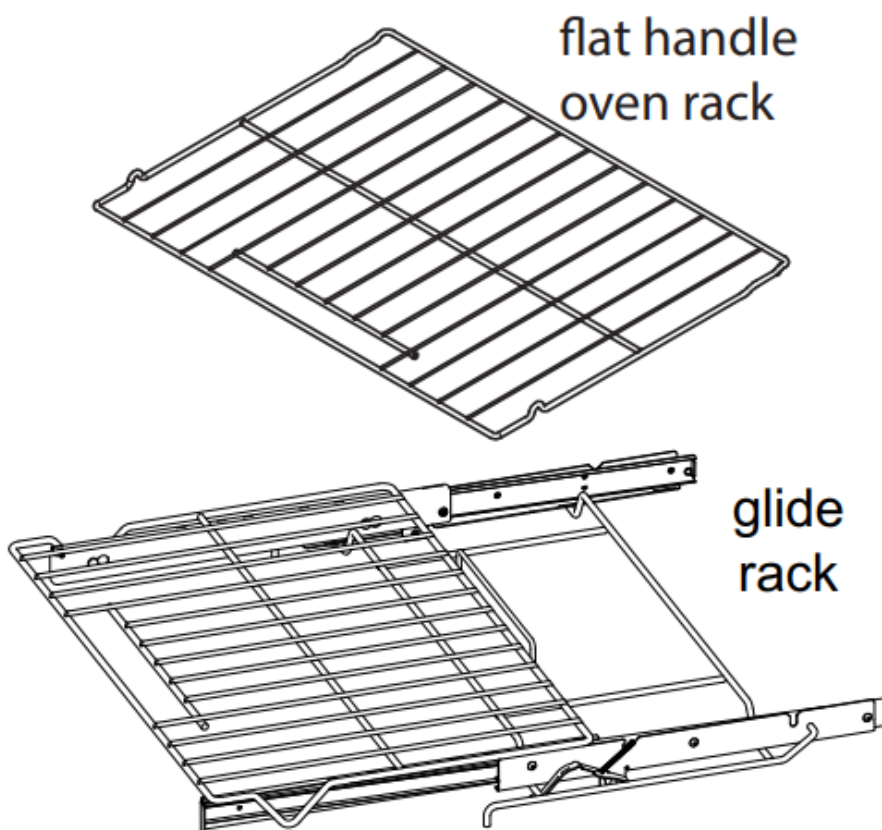

Figure 1: Do not block oven vent location

Type of oven racks



Oven Rack Descriptions

- Flat oven racks (or the flat handle oven rack) may be used for most cooking needs and may be placed in most oven rack positions.
- The fully extendable oven glide rack allows you to effortlessly extend your food away from the oven.

Removing, replacing, and arranging flat or offset oven racks

To arrange - Always arrange the oven racks when the oven is cool (prior to operating the oven).

To remove - Pull the oven rack straight forward until it reaches the stop position. Lift up front of oven rack slightly and slide out.

To replace - Place the oven rack on the rack guides on both sides of oven walls. Tilt the front of oven rack upward slightly and slide the oven rack back into place. Be sure oven racks are level before using.

Removing and Replacing the Glide Racks

The fully extendable Glide rack makes food preparation easier. This oven rack has glide tracks that allow the rack to be pulled away from the oven without rubbing the sides of the oven wall.

To remove - Make sure the baking rack is in the closed position. Using one hand, reach through handle opening and grasp both the upper and lower portions of the glide rack as shown in Figure 2.

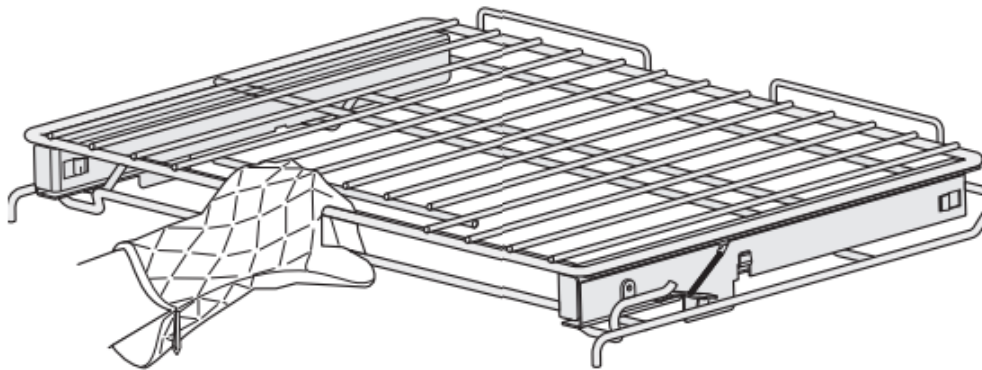

Figure 2: Grasp both rack sections

While holding both sections, pull the glide rack out of the oven until the stop position is reached (Figure 3).

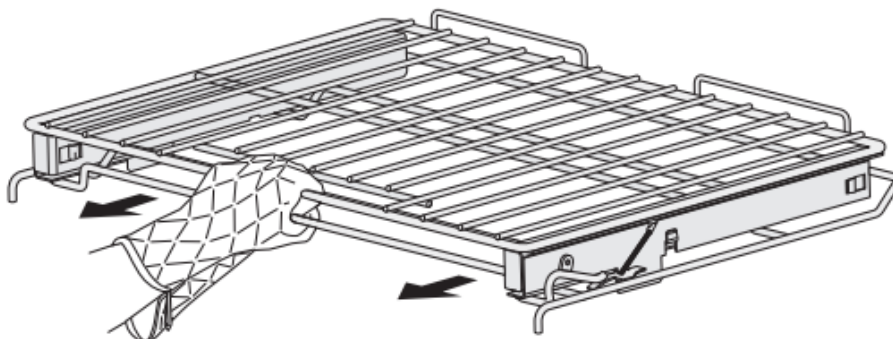

Figure 3: Pull rack to stop position

Using both hands, lift up the front of the rack slightly and continue to pull the rack away from the oven (Figure 4). Be sure to grasp both upper and lower rack portions together when removing or handling the glide rack.

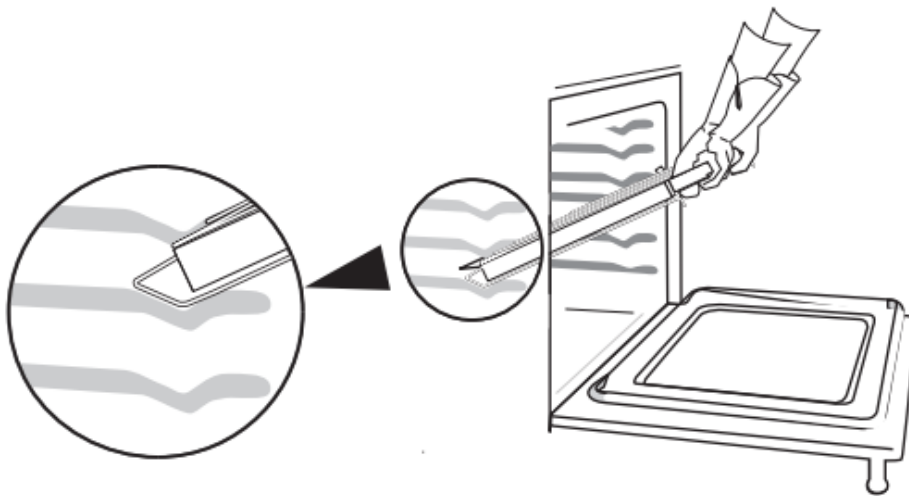

Figure 4: Remove and replace using both hands

The rack portions move independently and are difficult to handle unless held together.

To replace - Make sure the baking rack is in the closed position. Grasp both upper and lower portions of glide rack. Lift and hold the rack level between the oven cavity walls. Tilt the front of the rack upward slightly and slide the rack completely into position.

Important: To prevent possible damage to the oven, do not attempt to close the oven door until all the oven racks are fully positioned back inside the oven cavity.

SETTING OVEN CONTROLS

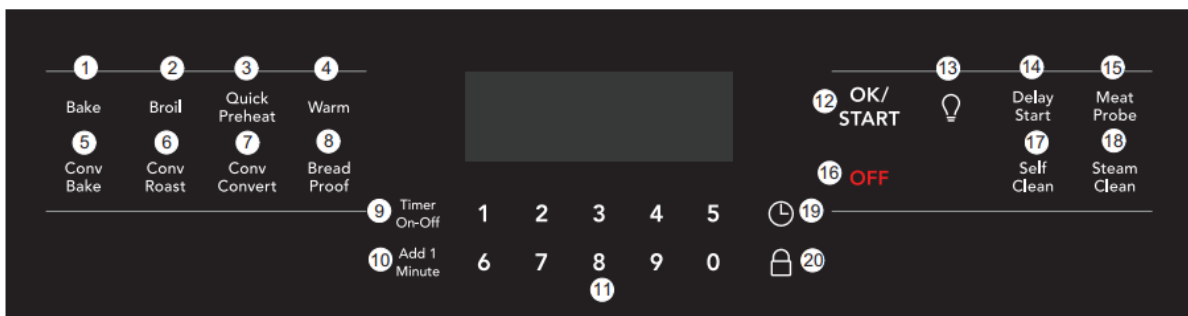

Oven Control Features

1. Bake - Use to enter normal baking temperatures for recipes that call for regular baking.
2. Broil - Selects normal broil function for direct heat cooking.
3. Quick Preheat - Best used for single rack baking with packaged, convenience, and made from scratch foods.

4. Warm - Use to keep cooked foods at serving temperature.
5. Conv Bake - Circulates the oven heat evenly and continuously for baking foods.
6. Conv Roast - Uses a convection fan to gently brown meats and poultry and seal in the juices.
7. Convection Convert - Converts standard bake temperatures to convection temperature in the convection bake feature.
8. Bread Proof - Maintains a warm environment useful for rising of yeast-leavened products.
9. Timer on-off - Use to set or cancel the minute timer. The minute timer does not start or stop any cooking function.
10. Add 1 Min - Use to add additional minutes to the timer.
11. 0 through 9 keys - Use to set temperature and set clock.
12. OK/START - Use to start cooking functions and when setting the clock.
13. Oven Light - Use to turn on internal light. Will turn on when the oven door is open.
14. Delay Start - Add to any cooking function and Self Clean to program a delayed starting time.
15. Meat Probe - Use when cooking meat like roasts, hams or poultry to cook to the desired internal temperature without any guesswork.
16. OFF - Use to turn off all cooking functions.
17. Self Clean - Use to set self-clean cycle between 2 and 4hrs.
18. Steam Clean - Use as a time saving method for cleaning light soils.
19. Set Clock - Use set the time of day
20. Oven Lock - Use to lock out oven controls.



| Feature | Mode | Min.Temp. / Time | Max Temp. /Time |
|---------------|---------------|------------------------|-------------------------------|
| Quick Preheat | | 170°F (77°C) | 550°F (288°C) |
| Bake | | 170°F (77°C) | 550°F (288°C) |
| Broil | | 400°F (205°C) | 550°F (288°C) |
| Conv Bake | | 170°F (77°C) | 550°F (288°C) |
| Conv Roast | | 170°F (77°C) | 550°F (288°C) |
| Meat Probe | | 140°F (60°C) | 210°F (99°C) |
| Warm | | 170°F (77°C) | until canceled |
| Bread Proof | | 100°F (38°C) | until canceled |
| Timer | | 0:01 Min. | 11:59 Hr./Min. |
| Clock Time | 12 Hr. 24 Hr. | 1:00 Hr./Min. 0:00 Min | 12:59 Hr./Min. 23:59 Hr./Min. |
| Delay Start | 12 Hr. 24 Hr. | 1:00 Hr./Min. 0:00 Min | 12:59 Hr./Min. 23:59 Hr./Min |
| Self Clean | | 2 hours | 4 hours |

Note: An entry acceptance tone (1beep) will sound each time a key is touched (the oven lock key is delayed 3 seconds). An entry error tone (3 short beeps) will sound if the entry of the temperature or time is below the minimum or above the maximum settings for the feature.

Setting the Clock

When the appliance is first powered up, **12:00** will flash in the display (Figure 5). The time of day must first be set before operating the oven.



A digital display showing the time 12:00 in a large, black, seven-segment font.

Figure 5: 12:00 in display before setting the clock

To set the clock:

To Set Clock to **1:30**:

1. Press .
2. Enter **1 3 0** using numeric keys.
3. Press **OK/START**.

Important note:

The clock cannot be changed when a Self Clean, Delay Start, or cooking feature is active.

Setting 12 Hour or 24 Hour display mode

The clock display mode allows you to select 12 hr or 24 hr modes. The factory pre-set clock display mode is 12 hours.

To set 12 hr or 24 hr display mode:

1. Press and hold  for 6 seconds.
2. Press Self Clean to toggle between 12 Hr day or 24 Hr day display modes (Figure 6).
3. Press OK/START to accept the choice.

A digital display showing two options: "12 Hr dAY" and "24 Hr dAY" in a large, black, seven-segment font.

Figure 6: 12 Hr dAy and 24 Hr dAy settings

Add 1 Min

Use the Add 1 Min feature to set additional minutes to the timer. Each press of the key will add 1 additional minute. If Add 1 Min is pressed when the timer is not active, the timer will activate and begin counting down from 1 minute.

To add 2 minutes to the timer:

Press Add 1 Min twice.

Setting Timer

The minute timer allows you to track your cooking times without interfering with the cooking process. The timer may be set from a minimum time of 1 minute to a maximum of 11 hours and 59 minutes.

To set timer for 5 minutes:

1. Press Timer On-Off.
2. Enter 5 using numeric keypad.
3. Press Timer On-Off to start the timer. When set time ends, END will show in the display and the control will sound a beep three times every 30 seconds until Timer On-Off key is pressed.

To cancel the timer when active, press Timer On-Off again.

Important note:

- The timer does not start or stop the cooking process. It serves as an extra minute timer that will beep when the set time has run out. The timer may be used alone or while using any of the other oven functions.
- When timer is set for more than 1 hour it will display hours and minutes until 1 hour remains. When less than 1 hour remains, the display counts down in minutes and seconds. With less than 1 minute remaining, only seconds will display.
- If the timer is active during a cooking process, the timer will show in the display. To view the status of any other active oven function, press the key of the cooking function once and it will appear in the display for a few seconds.

Changing between continuous bake setting or 12 hour energy saving

The oven control has a factory preset built-in 12 Hour Energy Saving feature that will turn off the oven if the oven is left on for more than 12 hours. The control may be programmed to override this feature to bake continuously.

To change between continuous bake or 12 hour energy saving feature:

1. Press and hold Timer On-Off for 6 seconds
2. Press Self Clean to toggle between 12 Hour OFF or Stay On feature (Figure 7).
3. Press OK/START to accept choice.

The image shows a digital display with two options: '12 Hr OFF' on the left and 'StAY On' on the right. The text is in a stylized, blocky font typical of an oven's digital display.

Figure 7: 12 hr energy saving (L) continuous setting (R)

Changing temperature display from Fahrenheit to Celsius

The electronic oven control is set to display °F when shipped from the factory. The display may be changed to show either °F or °C oven temperatures.

To change temperature display mode from °F to °C or from °C to °F:

1. Press and hold Broil for 6 seconds.
2. Once F (or C) appears in the display, press Self Clean to toggle between Fahrenheit and Celsius temperature display modes (Figure 8).
3. Press OK/START to accept the choice.

Important note:

The oven temperature display cannot be changed during the cooking process or if a delay start has been set or self clean is active.



Figure 8: Display showing Fahrenheit and Celsius

Setting Silent or Audible Control mode

Silent mode allows the oven control to operate without audible tones. The control may be programmed for silent operation and later reset to operate with all the normal audible tones.

To set for silent or audible mode:

1. Press and hold Delay Start for 6 seconds.
2. Press the Self Clean key to toggle between bEEP On or bEEP OFF (Figure 9).
3. Press OK/START to accept the choice.



Figure 9: Display showing audible and silent operation

Setting Oven Lockout

The control can be programmed to lock the oven door and lockout the oven control keys.

To activate the oven lockout features:

1. Be sure oven door is completely closed.
2. Press and hold the lock key for 3 seconds. The motor driven door latch mechanism will begin locking the oven door automatically. Do not open the oven door. Allow about 15

seconds for the oven door to completely lock. Once door is locked, the word DOOR with a lock icon will appear in the display.

To cancel the oven lockout feature:

1. Press and hold the lock key for 3 seconds. The motor door latch will begin unlocking the oven door automatically. Do not open the oven door. Allow about 15 seconds for the oven door to completely unlock.
2. When the word DOOR with a lock icon no longer displays, the oven door may be opened, and the oven control keypad will be available for use.

Important: If a control key is pressed when oven lockout is active, the control will triple beep indicating the key action is not available when the oven lockout feature is active.

Operating Oven Lights



The interior oven lights will automatically turn on when the oven door is opened. Oven lights will not operate during a self clean cycle. For best baking results, do not leave oven light on while cooking.

Press  to turn the interior oven lights on and off whenever the oven door is closed.

The interior oven lights are located on the side wall of the oven interior and are covered with a glass shield. The glass shield protects the bulb from high temperatures and should always be in place whenever the oven is in use.

To replace the interior oven light, see “Replacing the Oven Light” in the “Care and Cleaning” section

Quick Preheat

Quick Preheat is available for single rack baking with packaged, convenience foods and foods made from scratch can be programmed for temperatures between 170°F and 550°F. Follow the recipe or package directions for food preparation time and temperature. When quick preheat is complete, a reminder tone will sound and food should be placed in the oven.

CAUTION

Always use pot holders or oven mitts when using the oven. When cooking the oven interior, oven racks, and cooktop will become very hot which can cause burns.



During quick preheat function, the bake element will cycle on and off. The convection fan will turn on and stay on while oven is preheating and then cycle on and off as needed during cooking. Depending on your preference for doneness cooking times may vary. Watch food closely.

Important:

- Always place food in center of the oven on rack position 2 (Glide rack) or 3 (Flat rack) (Figure 10). Place the food as shown in Figure 10.
- For best results when baking batter and dough-based items such as cookies and pastries, use convection bake function and place food in oven when the reminder tone sounds signaling the oven is fully preheated.
- Food may need to be removed early and should be checked at minimum recommended bake time.

To set the preheat temperature for 350°F:

1. Arrange the interior oven racks.
2. Press Quick Preheat. 350 will appear in the display.
3. Press OK/START.
4. 350 and QUICK PREHEAT will be displayed while the oven is preheating.



5. Press OFF when baking is complete or to cancel the preheat feature.

To change preheat temperature while oven is preheating (ex: changing from 350°F to 425°F):

6. Enter the new preheat temperature. Press 4 2 5.
7. Press OK/START. 425 will show in the display.
8. When baking is complete, press OFF.

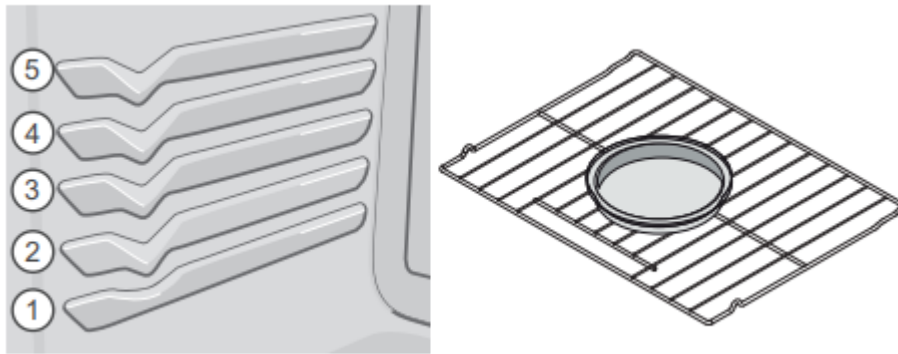

Figure 10: Oven rack positions; single rack baking

Note: The oven is equipped with cooling fans that turn on when the oven reaches a high enough temperature and will remain on until the oven cavity has cooled. In the double wall oven the cooling fan in the idle oven cavity will turn on if needed when the temperature in the active oven becomes hot enough. Cooling fans may remain on for a time after the oven function has been canceled. This is normal.

Setting Bake

Bake cooks with heat that rises from the oven bottom. The heat and air circulate naturally in the oven. A reminder tone will sound indicating when the set bake temperature is reached and to place the food in the oven. The convection fans will turn on in preheat and then cycle on and off as needed during baking. Bake may be set for any oven temperature between 170°F (77°C) to 550°F (288°C).

CAUTION

Always use pot holders or oven mitts when using the oven. When cooking the oven interior, oven racks, and cooktop will become very hot which can cause burns.

Baking tips

- Fully preheat the oven before baking items like cookies, cakes, biscuits and breads.
- Use the convection bake function for best results when baking cookies on multiple racks.
- Bake is the best function to use for baking cakes.
- For best results when baking layer cakes using two oven racks, place racks in positions 1 (flat) and 3 (glide) and place pans as shown in Figure 11.
- When using any single rack for baking cookies, cakes, biscuits, or muffins use rack position 3 (flat) or 2 (glide).
- Allow at least 2 inches (5 cm) of space between bakeware for proper air circulation.
- Dark or dull bakeware absorbs more heat than shiny bakeware, resulting in dark or over browned foods. It may be necessary to reduce oven temperature or cook time to prevent overbrowning of some foods.

- Shiny pans are recommended for cakes, cookies, and muffins.
- Do not open oven door often. Opening the door will reduce the temperature in the oven and may increase cook time.

To set Bake for (default) oven temperature of 350°F:

1. Press Bake.
2. 350° will appear in the display.
3. Press OK/START.

To cancel Bake at any time, press OFF.

To change the oven temperature to 425°F when the oven is baking:

1. Enter new temperature of 4 2 5 using numeric keys.
2. Press OK/START.
3. To cancel Bake at any time, press OFF.

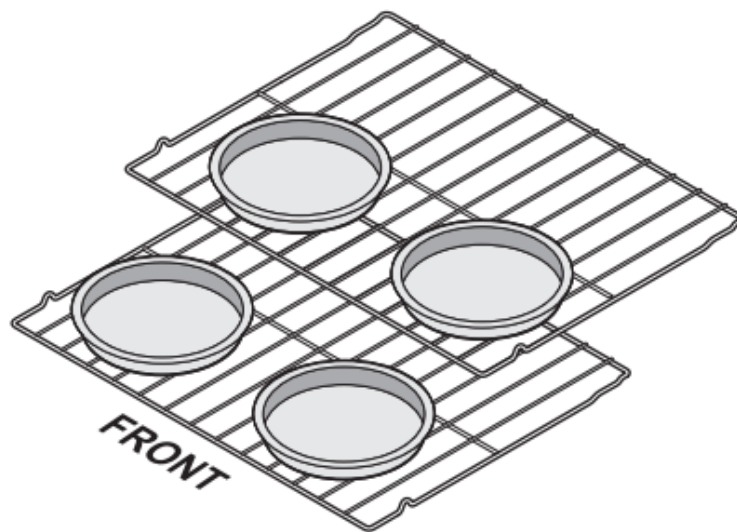
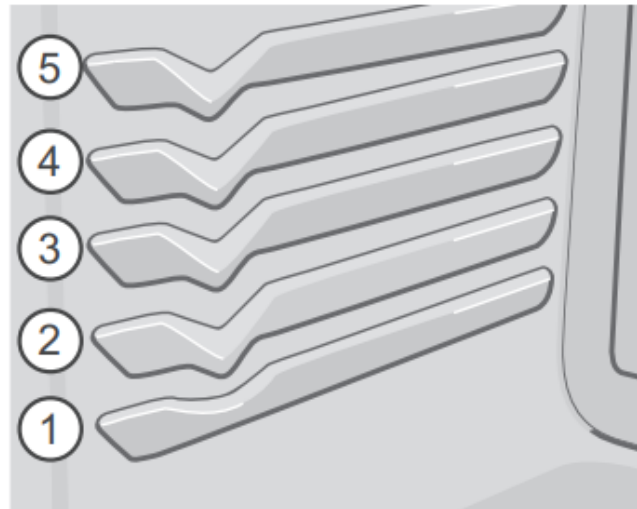

Figure 11: Pan placement for best results

Important: The oven will bake no longer than 12 hours. If you wish to bake for a longer period, see “Changing between continuous bake setting or 12 hour energy saving on page 18 for detailed information.

Convection Bake

Convection Bake uses a fan to circulate the oven's heat uniformly around the oven. This improved heat distribution allows for even cooking and browning. Heated air flows around the food from all sides.

Convection bake may be set for any oven temperature between 170°F (77°C) and 550°F (288°C).

Benefits of convection cooking include:

- Multiple rack baking.

Baking tips

- Fully preheat the oven before baking items like cookies, cakes, biscuits and breads.

- When baking cakes using two oven racks place bakeware in positions 1 (flat) and 3 (glide) and place bakeware as shown in Figure 12.
- When using any single rack for baking cookies, cakes, biscuits or muffins, use rack position 3 (flat) or 2 (glide).
- Unless the recipe is written for convection cooking, use Conv Convert to reduce oven temperature from the recipe's recommended oven temperature.

To set convection bake with a default oven set temperature of 350°F:

1. Press Conv Bake.
2. Conv Bake and 350° will appear in the display.
3. Press OK/START. The convection fan will turn on and stay on during the cooking process.
4. To cancel convection bake at any time, press OFF.

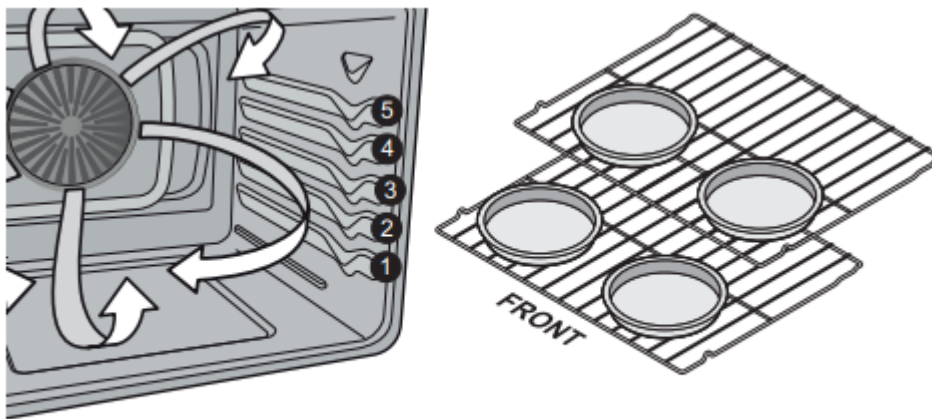

Figure 12: Rack positions and pan placement

Setting Convection Convert

Pressing the Convection Convert key automatically converts the cooking temperature entered for any standard baking recipe to the lower temperature required for convection baking.

To set the oven for convection bake with a standard baking recipe temperature of 400°F:

1. Arrange interior oven racks.
2. Press Conv Bake.
3. Press 4 0 0.
4. Press Conv Convert.
5. Press OK/START.
6. Place food in the oven.

NOTE

Pressing OFF will stop the feature at any time.

Important note:

- Convection convert may only be used with the Convection Bake function.
- When using convection convert, bake time reductions may vary depending on the oven set temperature.
- If the oven door is opened when any convection function is active, the convection fan will stop rotating until the oven door is closed.
- Do not open the oven door often. Opening the door will reduce the temperature in the oven and may increase the cooking time necessary for best results.

Setting Delay Start

Delay Start sets a delayed starting time to oven cooking or cleaning functions. Prior to setting a delay start, be sure the time of day is set correctly. Delay Start must be set when programming the cooking function.

WARNING

Food Poisoning Hazard. Do not let food sit for more than one hour before or after cooking. Doing so can result in food poisoning or sickness. Foods that can easily spoil such as milk, eggs, fish, meat or poultry, should be chilled in the refrigerator first. Even when chilled, they should not stand in the oven for more than 1 hour before cooking begins, and should be removed promptly when finished cooking.

To program oven for a delay start beginning at 5:30, and for baking at 375°F:

1. Press Bake.
7. Enter 3 7 5 using numeric keypad.
2. Press Delay Start.
3. Enter 5 3 0 using numeric keypad.
4. Press OK/START to accept.
5. The oven will turn on when the delay start time (5:30) is reached.

Important note:

Delay Start may be set using a 24 hr clock. To set clock for 24 Hr operation, See “Setting 12 Hour or 24 Hour display mode” on page 18 for more information. The Delay Start feature may be used with Convection Bake, Convection Roast, Convection Convert, Bake, Broil and Self Clean functions.

Bread Proof

The bread proof feature maintains a warm environment useful for rising yeast-leavened products.



The following temperature settings apply to the bread proof feature:

- Bread proof setting: 100°F/38°C.

To set oven to Bread Proof:

1. Press Bread Proof.
2. PrF will appear in the display.
3. Press OK/START to accept.
4. The oven will maintain the proofing temperature. Use oven light to check on progress. Turn light off after checking.
5. When finished proofing press OFF.

Setting Broil

Use the broil function to cook foods that require direct exposure to radiant heat for optimum browning results. Broiling may produce smoke. If smoke is excessive, place food further away from the element.

Broil is preset to 550°F and may be set to any temperature between 400°F (205°C) and 550°F (288°C).

Important: Broiler pans and inserts allow the grease to drain away from the high heat of the broiler. Do not use the pan without the insert. Do not cover the insert with foil - the exposed grease could ignite.

Note: OPEN DOOR BROIL SHUTOFF: If the oven door is left open during Broil for more than 3 minutes an alarm will sound to notify the user to close the oven door. If the door is not closed the oven will turn off within 30 seconds of the open door alarm.

To set broil with the default broil oven temperature of 550°F:

1. Arrange the oven racks when cool. For optimum browning results, preheat oven for 2 minutes before adding food. Broil can be set with Start Time.
2. Position bakeware in oven.
3. Press Broil. Broil with oven door closed.
4. Press OK/START.
5. Broil on one side until food is browned; turn and broil other side until done to your satisfaction.
6. When finished broiling, press OFF.

To cancel broil at any time, press OFF.

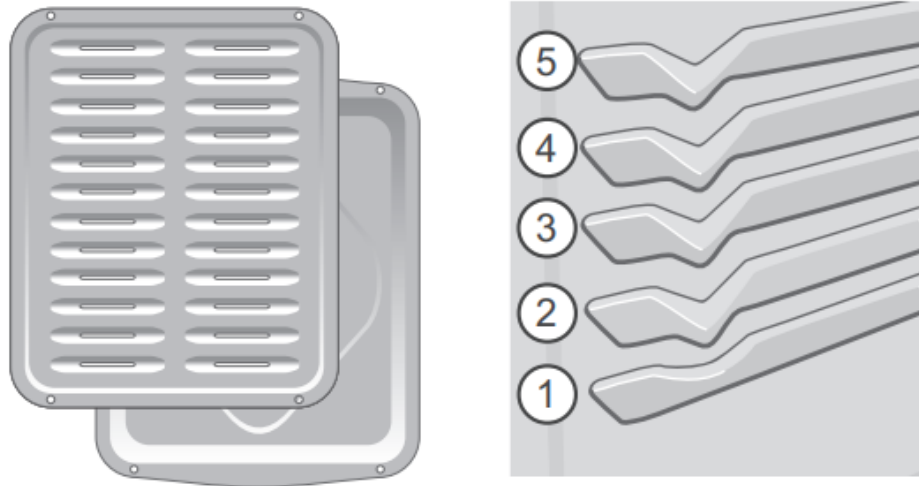

Figure 13: Broil pan with insert(L) Rack positions (R)

Important notes:

- Always arrange oven racks when the oven is cool.
- Broil with oven door closed. If broiling with door open, an alarm will sound alerting you to close the door. If left open, the Broil function will be canceled.
- For best results when broiling, use a broil pan with broil pan insert designed to drain the fat from the food and help avoid spatter and reduce smoking.
- When broiling, always pull the oven rack out to the stop position before turning or removing food.

Fig. 14 Broil Suggestions

| Food | Rack Position | Temperature | Cook time (minutes) | | Internal Temperature | Doneness |
|-----------------------|---------------|---------------|---------------------|----------|----------------------|----------|
| | | | 1st side | 2nd side | | |
| Steak 1" thick | 4 | 550°F (288°C) | 5 | 4 | 140°F (60°C) | Rare* |
| Steak 1" thick | 4 or 5 | 550°F (288°C) | 6 | 4 | 145°F (63°C) | Medium |
| Steak 1" thick | 4 or 5 | 550°F (288°C) | 8 | 7 | 170°F (77°C) | Well |
| Pork Chops 3/4" thick | 4 | 550°F (288°C) | 12 | 10 | 170°F (77°C) | Well |
| Chicken bone-in | 3 | 450°F (232°C) | 20 | 10 | 170°F (77°C) | Well |
| Chicken boneless | 4 | 450°F (232°C) | 8 | 6 | 170°F (77°C) | Well |
| Fish | 4 | 550°F (288°C) | as directed | | 170°F (77°C) | Well |
| Shrimp | 4 | 550°F (288°C) | as directed | | 170°F (77°C) | Well |
| Hamburger 1" thick | 4 | 550°F (288°C) | 9 | 7 | 145°F (63°C) | Medium |
| Hamburger 1" thick | 4 | 550°F (288°C) | 10 | 8 | 170°F (77°C) | Well |

* The U.S. Department of Agriculture states, "Rare fresh beef is popular, but you should know that cooking it to only 140°F (60°C) means some food poisoning organisms may survive." (Source: Safe Food Book, Your Kitchen Guide) The lowest temperature recommended by the USDA is 145°F (63°C) for medium rare fresh beef. For well done 170°F (77°C).

NOTE: Broiling is direct heat cooking and will produce some smoke. If smoke is excessive, place food further away from element. Always watch foods carefully to prevent burning.

Convection Roast

Convection roast combines a cook cycle with the convection fan and element to rapidly roast meats and poultry. Heated air circulates around the meat from all sides, sealing in juices and flavors. Meats cooked with this feature are crispy and brown on the outside while staying moist inside.

Benefits of Convection Roasting:

- Some foods cook up 25 to 30% faster, saving time and energy.
- No special pans or bakeware required.
- Preheating is not necessary for most meats and poultry.
- Be sure to carefully follow your recipe's temperature and time recommendations or refer to the convection roast chart for additional information.

To set Convection Roast:

1. Place the insert on broiler pan. Place meat (fat side up) on insert.
2. Make sure the insert is securely seated on top of the broiler pan. Do not use the broiler pan without the insert.
3. Place prepared food on oven rack and slide into oven.
4. Close the oven door.
5. Press Conv Roast.
6. Enter desired temperature using numeric keys.
7. Press OK/START.
8. When cooking is completed or to cancel convection roast press OFF.

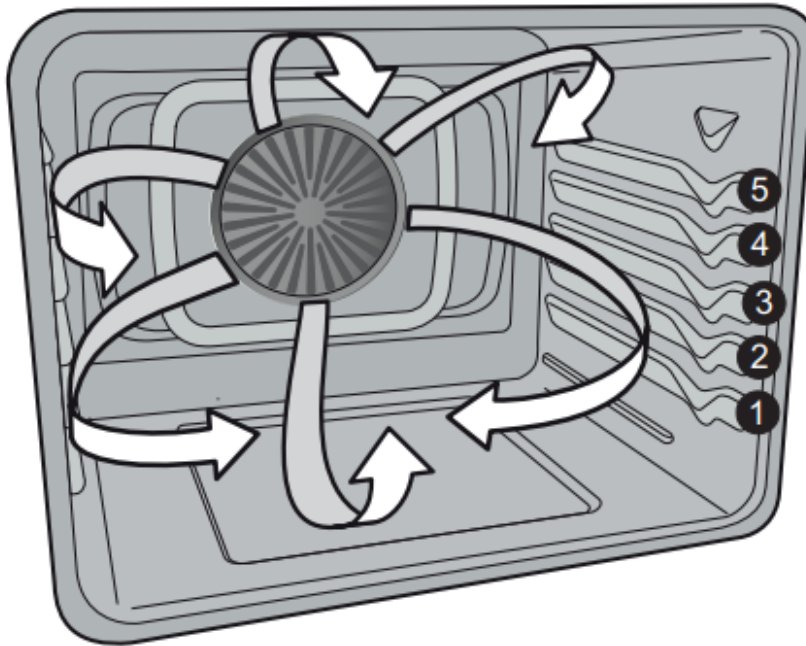

Figure 15: Convection roasting on lower oven racks

Convection Roasting tips:

- Preheating for convection roast is not necessary for most meats and poultry.
- Arrange oven racks so large cuts of meat and poultry are on the lowest rack of the oven.
- Smaller roasts and poultry should be cooked using rack position 2 glide or 3 flat.
- Since convection roast cooks faster, may be able to reduce cook times as much as 25% from the recommended time of your recipe (check the food at this time). Then if needed, increase cook time until the desired doneness is obtained.
- Carefully follow your recipe's temperature and time recommendations or refer to the convection roast recommendations for additional information.
- Do not cover foods when dry roasting - covering will prevent the meat from browning properly.
- When cooking meats use the broiler pan and insert. The broiler pan will catch grease spills and the insert helps prevent grease splatters.
- It is not recommended to roast chicken on a roasting rack. Use a deep pan instead.

Table 1: Convection roasting temperature and time recommendations

| Meat | | Weight | Oven Temp | Internal T |
|---------|----------------------|--------------|----------------------------|---------------|
| Beef | Standing rib roast* | 4 to 6 lb. | 350°F (177°C) | *160°F (71°C) |
| | Rib eye roast* | 4 to 6 lb. | 350°F (177°C) | *160°F (71°C) |
| | Tenderloin roast | 2 to 3 lb. | 400°F (204°C) | *160°F (71°C) |
| Poultry | Turkey whole** | 12 to 16 lb. | 325°F (163°C) | 180°F (82°C) |
| | Turkey whole** | 16 to 20 lb | 325°F (163°C) | 180°F (82°C) |
| | Turkey whole** | 20 to 24 lb. | 325°F (163°C) | 180°F (82°C) |
| | Chicken | 3 to 4 lb. | 350°F-375°F (177°C-191°C)* | 180°F (82°C) |
| Pork | Ham roast, fresh | 4 to 6 lb. | 325°F (163°C) | 160°F (71°C) |
| | Shoulder blade roast | 4 to 6 lb. | 325°F (163°C) | 160°F (71°C) |
| | Loin | 3 to 4 lb. | 325°F (163°C) | 160°F (71°C) |
| | Pre-cooked ham | 5 to 7 lb. | 325°F (163°C) | 160°F (71°C) |

* The U.S. Department of Agriculture states, “Rare fresh beef is popular, but you should know that cooking it to only 140°F (60°C) means some food poisoning organisms may survive.” (Source: Safe Food Book, Your Kitchen Guide) The lowest temperature recommended by the USDA is 145°F (63°C) for medium rare fresh beef. For well done 170°F (77°C)** Stuffed turkey requires additional roasting time. Shield legs and breast with foil to prevent over browning and drying of the skin.

Setting the Sabbath Feature (for use on the Jewish Sabbath and Holidays)





For further assistance, guidelines for proper usage, and a complete list of models with the Sabbath feature, please visit the web .

This appliance provides special settings for use when observing the Jewish Sabbath/Holidays. Sabbath mode disables all audible tones or visual display changes on the oven control. Bake is the only cooking feature available while in the Sabbath mode. Oven controls are locked during Sabbath mode.

You must first set the Bake feature and temperature(s) needed for the oven and Delay Start options (if needed). Any settings made prior to setting the Sabbath mode will be visible in the displays.

The Sabbath mode will override the factory preset 12 hour energy saving mode, and the appliance will stay on until the cooking features are canceled. If any of the cooking features are canceled when the appliance is in the Sabbath mode, no audible or visual indicators will be available to verify the cancellation.

If the oven interior lights are needed, be sure to activate them prior to setting the Sabbath mode. Once the oven light is turned on and the Sabbath mode is active, the oven light will remain on until the Sabbath mode is turned off and the oven lights are turned off. The oven door will not activate the interior oven lights when the oven door is opened or closed.

It is recommended that any oven temperature modification made within an active Sabbath mode be followed with two presses of the OK/START key. This will insure the oven remains on even if an attempt is made to set the oven temperature outside of its temperature range.

If the oven temperature is set outside of the temperature range, the oven will default to the nearest available temperature. Try to set the desired oven temperature again.

WARNING Food poisoning hazard. Do not let food sit for more than one hour before or after cooking. Doing so can result in food poisoning or sickness. Foods that can easily spoil such as milk, eggs, fish, meat or poultry, should be chilled in the refrigerator first. Even when chilled, they should not stand in the oven for more than 1 hour before cooking begins, and should be removed promptly when finished cooking.

Important:

- Do not attempt to activate any other oven function except Bake while the Sabbath feature is active. The following keys will function correctly when the Sabbath feature is active: 0-9 number keypad, Bake, OK/START, and OFF. All other keys should not be used once the Sabbath feature is active.

- You may change the oven temperature once baking has started. Press Bake, use the numeric keypad to enter the oven temperature change (170°F to 550°F), and press OK/START (for Jewish Holidays only).
- Remember that the oven control will no longer provide audible tones or display any further changes when the Sabbath feature is active.
- The oven will remain on until canceled and therefore may only be used once during the Sabbath/Jewish Holidays.
- If a delay start time longer than 11 hours and 59 minutes is desired, set the oven control for the 24 hour day display mode setting. See “Setting 12 Hour or 24 Hour display mode” on page 18 for more information.

To program oven to Bake with default oven temperature of 350°F and activate the Sabbath feature:

1. Be sure the clock is set with the correct time of day.
2. Arrange oven racks, place bakeware in oven, and close oven door. Press Bake.
3. Note: If Delay Start is desired enter the time at this point. See “Setting Delay Start” on page 23 for detailed instructions.
4. Press OK/START.
5. Press and hold Self Clean and Delay Start simultaneously for about 3 seconds to set the Sabbath feature. Once the feature is set, SAb will appear in the display indicating the oven is properly set for the Sabbath feature (Figure 20).



Figure 20: Oven set for Sabbath baking

To turn the oven off and keep the Sabbath feature active:

1. Press OFF.

To turn off the Sabbath feature:

Press and hold both Self Clean and Delay Start simultaneously for at least 3 seconds to turn the Sabbath feature off. The control will provide an acceptance tone, and SAb will disappear from the display. The oven is no longer programmed for the Sabbath feature.

What to do during a power failure or power interruption after the Sabbath feature was activated:

Should you experience a power failure or interruption, the oven will shut-off. When power is restored the oven will not turn back on automatically. The oven will remember that it is set for the Sabbath, and the oven display will show the message SF for Sabbath failure (Figure 21).

The image shows the letters 'SF' in a large, black, digital font, representing a Sabbath failure message on an oven's display.

Figure 21: Display showing Sabbath failure

The food may be safely removed from the oven while still in the Sabbath feature, however the oven cannot be turned back on until after the Sabbath/Holidays. After the Sabbath observance turn off the Sabbath feature.

Press and hold both Self Clean and Delay Start keys for at least 3 seconds simultaneously to turn the Sabbath feature off. SF will disappear from the display, and the oven may be used with all normal functions.

Self Clean

A self cleaning oven cleans itself with high temperatures (well above normal cooking temperatures), which eliminate soils completely or reduces them to a fine powdered ash you can wipe away afterwards with a damp cloth. This function can be programmed for clean times between 2 and 4 hours.

Important: Before starting self clean read all following caution and important statements before starting a self clean cycle

CAUTION

- Do not leave small children unattended near appliance. During self clean cycle, the outside of the oven can become very hot and cause burns if touched.
- Do not line the oven walls, racks, oven bottom, or any part of the range with aluminum foil. This will cause permanent damage to the oven interior and destroy heat distribution, and will melt to the oven interior.
- Do not force the oven door open. This will damage the automatic door locking system. Use caution when opening the oven door after the self clean cycle ends. The oven may still be very hot and cause burns. To avoid possible burns, stand to side of oven when opening door to allow steam or hot air to escape.
- The health of some birds is extremely sensitive to fumes given off during the self clean cycle of any range. Move birds to a well ventilated room.

Important notes:

- Completely remove all oven racks and any accessories from oven cavity to avoid damage to oven racks. If the oven racks are not removed they may discolor.
- Remove all items from the oven and cooktop including cookware, utensils, and any aluminum foil. Aluminum foil will not withstand high temperatures from a self clean cycle and will melt.
- Do not spray oven cleaners or oven protective coatings in or around any part of the oven interior. Clean any soil from the oven frame, the door liner outside the oven door gasket, and the small area at the front center of the oven bottom (Figure 22). These areas heat sufficiently to burn soil on. Clean using soap and water prior to starting Self Clean.
- Remove any excessive spills. Any spills on the oven bottom should be wiped up and removed before starting a self clean cycle. To clean use hot, soapy water and a cloth. Large spills can cause heavy smoke or fire when subjected to high temperatures.
- Do not allow food spills with high sugar or acid content (such as milk, tomatoes, sauerkraut, fruit juices, or pie fillings) to remain on the surface as they may leave a dull spot even after cleaning.
- Do not clean the oven door gasket. The woven material in the gasket is essential for a good seal. Care should be taken not to rub, damage, or remove the oven door gasket. Doing so could cause damage to the door gasket and compromise the performance of the oven.

Figure 22: Areas to clean and areas to avoid (gasket)

- The kitchen area should be well ventilated using an open window, ventilation fan, or exhaust hood during the first self clean cycle. This will help eliminate the normal odors.
- Do not attempt to open the oven door when the OVEN LOCK indicator light is flashing. Allow about 15 seconds for the motorized door latch mechanism to completely lock or unlock the oven door.
- When the clean time finishes, the oven door will remain locked until the range has cooled sufficiently. In addition to the clean time that was programmed, you must allow about 1 additional hour for the oven to cool before you will be able to open the oven door.

Setting Self Clean

To set self clean:

1. Be sure the oven is empty and all oven racks are removed. Remove all items from the oven. Be sure oven door is completely closed.
2. Press Self Clean.

3. A 3 hour clean time will appear in the display. You may accept the 3 hour clean time or choose a different clean duration by entering any time between 2 and 4 hours clean time by entering the time using the numeric keys.
4. Press OK/START twice to activate self clean.
5. The warning to REMOVE RACKS will flash in the display and beep for 30 seconds to remind you that oven racks should be removed before a self clean.
6. The warning will end and Self Clean will start. The motor door lock will begin locking the oven door.

Important: Do not open the oven door while the lock motor is running or when any locking indicators or displays are showing. The oven door is completely locked in about 15 seconds. Once the oven door has locked, CLEAN will appear in the display indicating self clean has started.

Do not force the oven door open when self-clean is active.

This can damage the automatic door-locking system. Use caution when opening the door after self-clean cycle is complete; the oven may still be very hot.

When self clean is finished:

1. CLEAN message will turn off, and Hot will appear in display window.
2. Once the oven has cooled down (about 1 hour) and Hot is no longer displayed, the oven door may be opened.
3. When the oven interior has completely cooled, wipe away any residue or powdered ash with a damp cloth or paper towel.

Setting Delay Start Self Clean

To start a delay self clean with default clean time of 3 hours and a start time of 9:00 o'clock:

1. Be sure the clock is set with the correct time of day, the oven is empty, and all oven racks are removed. Be sure oven door is completely closed.
2. Press Self Clean.
3. Press Delay Start..
4. Using numeric keypad, enter 9 0 0.
5. Press OK/START twice to accept.

If it becomes necessary to stop self clean when active:

1. Press OFF.

Important: If self clean has heated the oven to a high temperature, allow enough time for the oven to cool. Before restarting self clean, be sure to read important notes below.



Important note:

- If your clock is set with the (default) 12 hr display mode, the delay start for a self clean can only be programmed to start up to 11 hours and 59 minutes after the time showing in the display (be sure to set the clock to current time before programming a Delay Start). To set a delay start Self Clean to begin 12 or more hour (maximum is 23 hours and 59 minutes) after the time of setting, be sure to first set the control in the 24 Hr display mode.
- If self clean was active and then interrupted by a power failure or canceled before the oven was thoroughly cleaned, it may be necessary to run another self clean cycle.
- If the oven temperature was high enough when self clean was interrupted the oven control may not allow another self clean cycle to be set for up to 4 hours.

Steam Clean

The Steam Clean feature offers a chemical free and time saving method to assist in the routine cleaning of small and light soils. For heavier baked on soils use the Self Clean feature.

CAUTION

Do not add bleach, ammonia, oven cleaner, or any other abrasive household cleaners to the water used for Steam Clean. Before cleaning any part of the oven, be sure all controls are turned off and the oven is cool. The oven may be hot and can cause burns.

Be sure the oven is level and cool before starting Steam Clean. If the oven temperature is above room temperature a triple beep will be heard and the function will not start. Steam Clean produces best results when started with a cool oven

To set a Steam Clean cycle:

1. Remove all racks and oven accessories.
2. Scrape or wipe loose debris and grease from the oven bottom.
3. Pour 1 cup of tap water onto the oven bottom. (Figure 23) Close oven door.

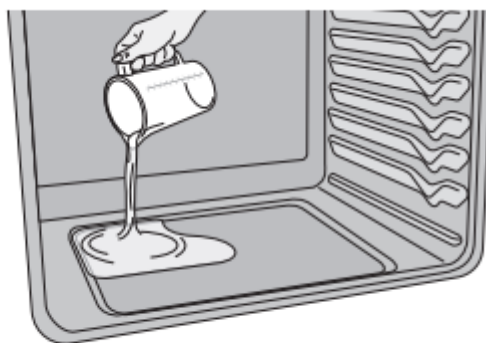

Figure 23: Add 1 cup of tap water

4. Press Steam Clean.
5. Press OK/START. St C will appear in the display.
6. To see time remaining in the Steam Clean cycle press Steam Clean key. The time left will show in the display for 6 seconds before returning to the time of day. Do not open the door during this time. If door is left open during Steam Clean for more than 4 minutes, d-O will appear in the display and the display will sound a triple beep until the door is closed.
7. When the steam clean cycle is complete an alert will sound and the END message will show in the display. Press OFF to return to the clock.
8. Take care opening the door when the steam clean is finished. Stand to the side of the oven out of the way of escaping vapor.
9. Wipe oven cavity and bottom. Do not clean oven door gasket (Figure 24). Avoid leaning or resting on the oven door glass while cleaning cavity.
10. To cancel Steam Clean at any time press OFF.



Figure 24: Clean around the oven door gasket

Important: Opening oven door during Steam Clean cycle prevents the water from reaching the temperature needed to clean. If the door is left open once Steam Clean starts, an alarm will sound alerting you to close the door.

- For best results, clean oven immediately after the cycle is complete. Steam clean works best for soils on the oven bottom.
- Place a paper towel or cloth in front of the oven to capture any water that may spill while wiping out.
- A non abrasive scouring pad, stainless steel sponge, plastic scraper, or eraser style cleaning pad (without cleaner) can be used for difficult soils. Moisten pads with water before use.
- Do not leave the residual water in the oven for any length of time.
- Some condensation or water vapor may appear close to the oven vent. This is normal. The oven gasket may become damp; do not wipe dry.

- Local water sources often contain minerals (hard water). If hard water deposits occur, wipe cavity with a 50/50 solution of water and vinegar or 50/50 solution of lemon juice and water.
- Steam clean cannot be programmed with a delay start.
- If Steam Clean results are not satisfactory, run a Self Clean. See “Self Clean” on page 33.

Restoring Factory Default Settings

Your appliance was set with predetermined (default) oven control settings. Over time, users may have made changes to these settings. The following options may have been modified since the appliance was new:

- 12 or 24 hr display mode
- All Meat Probe settings
- Continuous bake or 12 hour energy savings mode
- Silent or audible control
- Oven temperature display (Fahrenheit or Celsius)
- Oven temperature adjustments (UPO)

CAUTION All of the above user settings will be restored to the factory default settings.

To restore oven control to factory default settings:

1. Press and hold 7 on numeric keypad until acceptance tone sounds (about 6 seconds).
2. Press OK/START. The control has been reset with the default settings.

Adjusting Oven Temperatures

Your appliance has been factory calibrated and tested to ensure accurate baking temperatures. For the first few uses, follow your recipe times and temperature recommendations carefully. If you think the oven is cooking too hot or too cool for your recipe times, you may adjust the control so the oven cooks hotter or cooler than the oven temperature displayed.

Important: Do not use oven thermometers such as those found in grocery stores to check the temperature settings inside your oven. These oven thermometers may vary as much as 20 to 40°F degrees from actual temperatures.

The oven temperature may be increased as much as +35°F (+19°C) or decreased -35°F (-19°C) from the factory calibrated settings.

To increase or decrease the oven temperature by 20°F:

1. Press and hold Bake until the control produces an audible tone (about 6 seconds). The factory offset temperature of 0 (zero) should appear in the display.
2. Enter 2 0 using numeric keypad.

3. To offset the oven by -20°F, press self clean to toggle between + and -.
4. Press OK/START to accept change.

Important note:

- Oven temperature adjustments will not change the Broil, Self Clean, or Keep Warm temperatures.
- The oven temperature adjustment may be made if your oven control is set to display temperatures in °C (Celsius). Minimum and maximum settings for Celsius range from plus (+)19°C to minus (-) 19°C.

BEFORE USING MICROWAVE OVEN

About Your Microwave Oven

This Use and Care Manual is valuable: read it carefully and always save it for reference.

A good microwave cookbook is a valuable asset. Check it for microwave cooking principles, techniques, hints, and recipes.

NEVER use the microwave oven without the turntable and support or turn the turntable over so that a large dish could be placed in the microwave oven. The turntable will turn both clockwise and counterclockwise.

ALWAYS have food in the microwave oven when it is on to absorb the microwave energy.

When using the microwave oven at power levels below 100%, you may hear the magnetron cycling on and off. It is normal for the exterior of the microwave oven to be warm to the touch when cooking or reheating.

Condensation is a normal part of microwave cooking. Room humidity and the moisture in food will influence the amount of moisture that condenses in the microwave oven. Generally, covered foods will not cause as much condensation as uncovered ones. Ventilation openings must not be blocked.

The microwave oven is for food preparation only. It should not be used to dry clothes or newspapers.

All microwave ovens are rated by using the IEC Test Procedure at 1200 watts. If using recipes or package directions, check food a minute or two before the minimum time setting elapses and add time accordingly.

Radio or TV Interference

Should there be any interference caused by the microwave oven to your radio or TV, check that the microwave oven is on a different electrical circuit, relocate the radio or TV as far away from the microwave oven as feasible or check position and signal of receiving antenna.

About Microwave Cooking

- Arrange food carefully. Place thickest areas towards outside of dish.
- Watch cooking time. Cook for the shortest amount of time indicated and add more as needed. Food severely overcooked can smoke or ignite.
- Cover foods while cooking. Check recipe or cookbook for suggestions: paper towels, wax paper, microwave plastic wrap or a lid. Covers prevent spattering and help foods to cook evenly.
- Stir foods from outside to center of dish once or twice during cooking, if possible.
- Turn foods over once during microwaving to speed cooking of such foods as chicken and hamburgers.
- Large items like roasts must be turned over at least once.
- Rearrange foods such as meatballs halfway through cooking both from top to bottom and from the center of the dish to the outside.
- Use standing time. Always allow food to stand in or out of the oven after cooking power stops. Standing time after defrosting or cooking allows the temperature to evenly spread throughout the food, improving the cooking results. For inside oven standing time, you can program a "0" power stage of the cooking cycle. See Multiple Stage Cooking.
- Check for doneness. Look for signs indicating that cooking temperatures have been reached.

Doneness signs include:

- Food steams throughout, not just at edge.
- Center bottom of dish is very hot to the touch.
- Poultry thigh joints move easily.
- Meat and poultry show no pinkness.
- Fish is opaque and flakes easily with a fork.

About Foods

- Do not pop popcorn in your microwave oven unless in a special microwave popcorn accessory or unless you use popcorn labeled for use in microwave ovens.
- Foods with unbroken outer "skin" -- such as potatoes, hot dogs, sausages, tomatoes, apples, chicken livers and other giblets, and egg yolks -- should be pierced to allow steam to escape during cooking.
- Avoid heating baby food in glass jars, even with the lid off. Make sure all infant food is thoroughly cooked. Stir food to distribute the heat evenly. Be careful to prevent scalding when warming formula or breast milk. The container may feel cooler than the milk really is. Always test the milk before feeding the baby.

- Cook meat and poultry thoroughly—meat to at least an INTERNAL temperature of 160°F and poultry to at least an INTERNAL temperature of 170°F Cooking to these temperatures usually protects against food-borne illness.

About Utensils and Coverings

It is not necessary to buy all new cookware. Many pieces already in your kitchen can be used successfully in your new microwave oven. Make sure the utensil does not touch the interior walls during cooking.

Use these utensils for safe microwave cooking and reheating:

- glass ceramic (Pyroceram®), such as Corningware®
- heat-resistant glass (Pyrex®)
- microwave-safe plastics
- paper plates
- microwave-safe pottery, stoneware and porcelain
- browning dish (Do not exceed recommended preheating time. Follow manufacturer's directions.)

These items can be used for short-time reheating of foods that have little fat or sugar in them:

- wood, straw, wicker

DO NOT USE

- metal pans and bakeware
- dishes with metallic trim
- non-heat-resistant glass
- non-microwave-safe plastics (margarine tubs)
- recycled paper products
- brown paper bags
- food storage bags
- metal twist-ties
- styrofoam

Should you wish to check if a dish is safe for microwaving, place the empty dish in the microwave oven and microwave on HIGH for 30 seconds. A dish which becomes very hot should not be used.

The following coverings are suitable for microwave use:

- Paper towels are good for covering foods for reheating and absorbing fat while cooking bacon.
- Wax paper can be used for cooking and reheating.

- Plastic wrap that is specially marked for microwave use can be used for cooking and reheating. DO NOT allow plastic wrap to touch food. Vent so steam can escape.
- Lids that are microwave-safe are a good choice because heat is kept near the food to hasten cooking.
- Oven cooking bags are good for large meats or foods that need tenderizing. DO NOT use metal twist ties. Remember to slit bag so steam can escape.

Accessories

There are many microwave accessories available for purchase. Evaluate carefully before you purchase so that they meet your needs. A microwave-safe thermometer will assist you in determining correct doneness and assure you that foods have been cooked to safe temperatures.

The manufacturer is not responsible for any damage to the microwave oven when accessories are used.

About Children and the Microwave

Children below the age of 7 should use the microwave oven with a supervising person very near to them. Between the ages of 7 and 12, the supervising person should be in the same room.

At no time should anyone be allowed to lean or swing on the microwave oven door.

Children should be taught all safety precautions: use pot holders, remove coverings carefully, pay special attention to packages that crisp food because they may be extra hot.

Don't assume that because a child has mastered one cooking skill he/she can cook everything.

Children need to learn that the microwave oven is not a toy.

About Food Safety

Check foods to see that they are cooked to the United States Department of Agriculture's recommended temperatures.

- Fresh pork, ground meat, boneless white poultry, fish, seafood, egg dishes and frozen prepared food.: 160°F
- Leftover, ready-to-reheat refrigerated, and deli and carry-out "fresh" food.: 165°F
- White meat of poultry :170°F
- Dark meat of poultry: 175°F

To test for doneness, insert a meat thermometer in a thick or dense area away from fat or bone. Never leave the thermometer in the food during cooking, unless it is approved for microwave oven use.

Note

- Stay near the microwave oven while it's in use and check cooking progress frequently so that there is no chance of overcooking food.
- NEVER use the cavity for storing cookbooks or other items.
- Select, store, and handle food carefully to preserve its high quality and minimize the spread of food-borne bacteria.
- Keep the waveguide cover clean. Food residue can cause arcing and/or fires.
- Use care when removing items from the microwave oven so the utensil, your clothes, or accessories do not touch the safety door latches.

SETTING THE MICROWAVE

Microwave Features

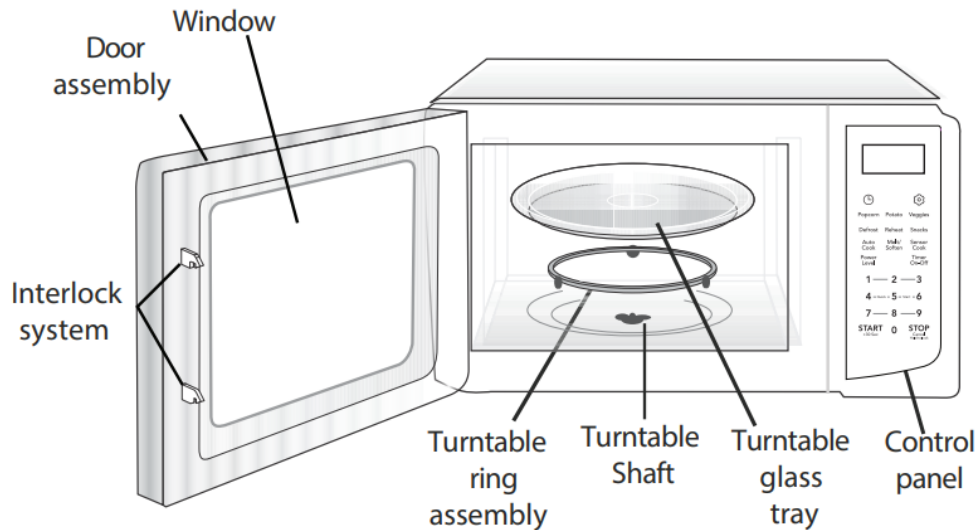

Figure 1: Microwave features

Display

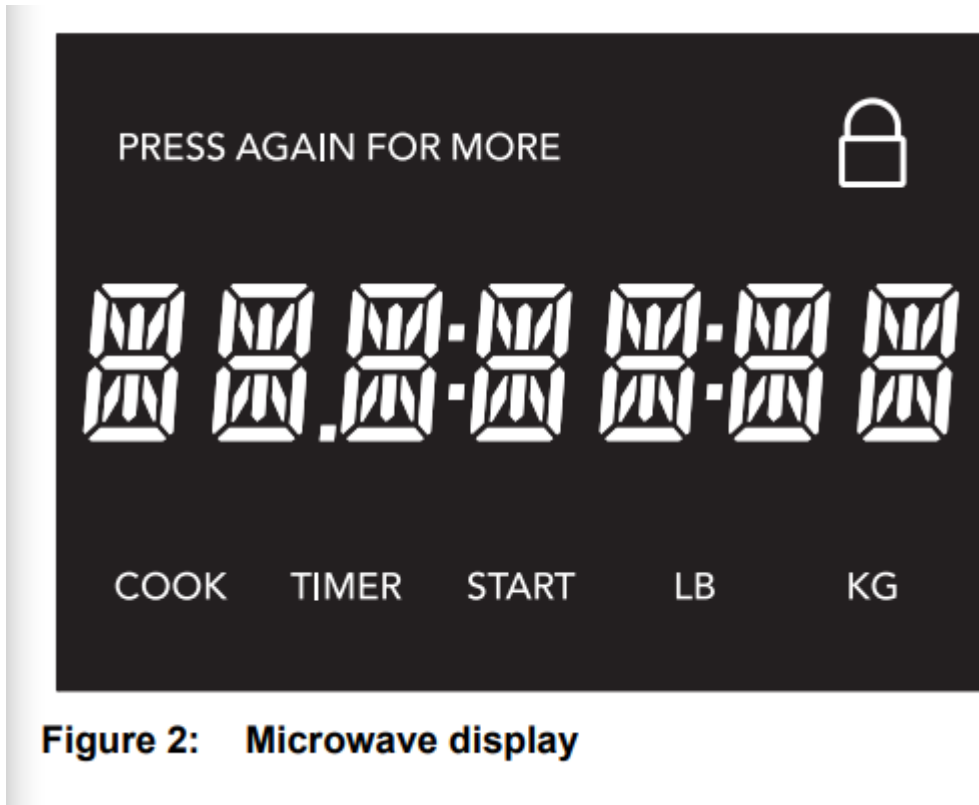

Figure 2: Microwave display

Before Operating the Microwave

Before operating your new microwave oven, make sure you read and understand this Use and Care manual completely.

CAUTION

To avoid risk of personal injury or property damage, do not operate the microwave oven empty.

To avoid risk of personal injury or property damage, do not use stoneware, aluminum foil, metal utensils, or metal trimmed utensils in the microwave oven.

Control Panel

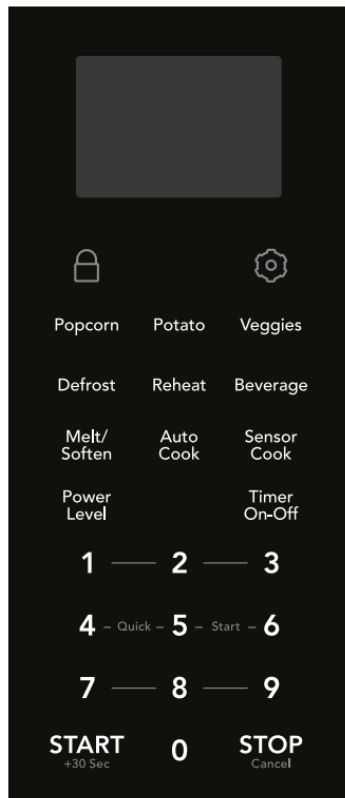

Figure 3: Microwave Control Pad

1. Lock: Use to lock the controls to prevent accidental use.
2. Settings / User Preferences
3. Presets
 - Popcorn
 - Potato
 - Veggies
 - Defrost
 - Reheat
 - Beverage
4. Melt/Soften
5. Auto Cook
6. Sensor Cook
7. Power level (10 power levels available)
8. Timer On-Off
9. Number Keys
10. START/+30Sec.
11. STOP/Cancel: Clears all previous settings if pressed before cooking starts. During cooking, press once to pause (and STAR

Quick Start

Microwave heating or cooking may be quickly set at 100% power level for 1 -9 minutes. Use the number keys 1-9 to choose the desired minutes of cook time (this option will only work using the 1-9 numeric pads.)

Press the number pad key for the desired number of minutes. The microwave will start a couple of seconds later.

When the time runs out, three long tones sound, and "FOOD READY" shows in the display.

Timed Heating

1. Use the number pad to enter the time in minutes and seconds. For example, to heat for 5 minutes and 30 seconds, enter 5 3 0.

Note: For time sets that start with numbers 1 - 9, the remaining numbers must be entered within 2 second from the first key press, otherwise the Quick Start time will be used.

2. Press START.

When the time runs out, three long tones sound, and "FOOD READY" shows in the display.

Timer

1. Press Timer On-Off.
2. Use the number pad to enter the time in minutes and seconds. For example, to heat for 5 minutes and 30 seconds, enter 5 3 0.
3. Press Timer On-Off.

The timer will start counting down. The microwave does not cook when just the timer is running. When the time runs out, three long tones sound.

Setting Power Level

Using the highest power level to heat foods does not always give the best results when some types of food need slower cooking, such as roasts, baked goods, or custards. Your oven has ten other power levels you may choose.

To set to cook at a lower power level:

1. Use the number pad to enter the time in minutes and seconds. For example, to heat for 5 minutes and 30 seconds, enter 5 3 0.

Note: For time sets that start with numbers 1 - 9, the remaining numbers must be entered within 2 second from the first key press, otherwise the Quick Start time will be used.

2. Press the Power Level pad until the desired level displays. For example, press once for high power (PL-HI). Press Power Level four times to change to 70% power (PL-70). The selected power level appears in the display.
3. Press START.

When the time runs out, three long tones sound, and "FOOD READY" shows in the display.

Multi-Stage Cooking

For best results, some microwave recipes call for different power levels or different lengths of time for cooking. Your microwave may be set to change from one stage to another automatically (2 stages maximum).

1. Use the number pads to enter the time for the first stage.

2. Press Power Level until the desired power for the first stage is shown.
 1. Use the number pads to enter the time for the second stage.
 2. Press Power Level until the desired power for the second stage is shown.
 3. Press START.

The display will show the time remaining in the first cooking stage. Three series of beeps will sound when the second cooking stage starts, and the display will show the time remaining for the second stage.

When the second stage time runs out, three long tones sound, and “FOOD READY” shows in the display.

Add Cook Time (+30 Sec)

Pressing the START pad once starts cooking at 100% power with 30 seconds of cooking time.

Pressing the START pad during cooking adds 30 seconds (for each press) to the cook time at the current power level.

NOTE: The “+30sec” function is not available when using the Defrost or any of the Preset features.

Defrost

The auto defrost feature provides you with the best defrosting method for frozen foods. The cooking guide will show you which defrost sequence is recommended for the food you are defrosting.

For added convenience, the Auto Defrost includes a built-in beep mechanism that reminds you to check, turn over, separate, or rearrange the food in order to get the best defrost results. Three different defrosting levels are provided: MEAT, POULTRY, and FISH.

To set automatic defrost:

1. Press Defrost until the correct food type displays. Table 1:Defrost Settings

| Key Press | Food |
|------------|---------|
| Defrost x1 | Meat |
| Defrost x2 | Poultry |
| Defrost x3 | Fish |

2. Press START.



3. Use the numeric keys to enter the weight of the food in pounds. The setting can be from 0.1 to 6.0 lbs.

4. Press START.

When the food is ready, three long tones sound, and "FOOD READY" shows in the display.

Sensor Cook

The Sensor Cook categories are designed to detect the increasing humidity released by the food during the cooking process. The microwave oven sensor will automatically adjust the cooking time to the type and amount of food. The food categories that are controlled with the humidity sensor are shown in Table 7.

Table 7: Popcorn Settings

| Key Press | Food |
|----------------|-----------------------------|
| Sensor Cook x1 | Frozen breakfast (8-12 oz.) |
| Sensor Cook x2 | Ground meat |
| Sensor Cook x3 | Fish or seafood |
| Sensor Cook x4 | Chicken breast |

For best results, do not use one of the Sensor Cook categories twice in succession on the same food portion. This may result in severely overcooked or burnt food. If the food appears to be undercooked, use one of the Easy Set pads or cook time pads to add more time.

Additional sensor cook suggestions are:

- Never start with less than 4 oz. of food.
- For best sensor cooking results, use proper containers and covers or wrap food with plastic.
- Always use microwave-safe containers. Never use tight-sealing plastic containers. They will prevent steam from escaping, and this will mislead the sensor, usually causing the food to overcook.

Be sure the outside of the cooking containers and the cavity of the microwave oven are dry before placing food inside. Excessive moisture turning into steam that does not result from the food cooking can mislead the sensor.

To set Sensor Cook:

1. Press Sensor Cook until the correct food type displays.
2. Press START.

When the food is ready, three long tones sound, and "FOOD READY" shows in the display.

The reheat feature is designed to detect the increasing humidity released by the food during the cooking process. The microwave oven sensor will automatically adjust the cooking time to the type and amount of food.

Table 8: Defrost Settings

| Key Press | Food | Amount | Key |
|-----------|--------------|--------------|---------|
| Reheat x1 | Dinner plate | 1-2 plates | Default |
| Reheat x2 | Soup/sauce | 1-2 cups | Default |
| Reheat x3 | Casserole | 1-4 servings | Default |

Notes concerning sensor reheat:

- For casseroles, add 2-3 tablespoons of liquid, cover with lid or vented plastic wrap. Stir when instructed from display.
- For canned foods, empty contents of can into a casserole dish or serving bowl. Cover dish with lid or vented plastic wrap. Let stand a few minutes before serving.
- For plates of food, arrange food on plate and add any butter or gravies, etc. Cover with loose-fitting lid or vented plastic wrap. After reheating, let stand a few minutes before serving.

To set Reheat:

1. Press Reheat until the correct food type displays.
2. Press START.
3. For soup/sauce, use the number keys to enter the quantity (skip for Default) and press START again.

When the food is ready, three long tones sound, and "FOOD READY" shows in the display.

Keypad Lock

The Keypad Lock prevents unwanted microwave oven operation, such as by small children. The microwave oven can be set so that the control panel is deactivated or locked.



Touch and hold the lock pad for 3 seconds. The lock icon lights up. "LOCKED" will show in the display if you attempt to set the controls.

To unlock the keypad, touch and hold the lock pad for 3 seconds. The lock icon will go out.

Set Clock

1. Press the Settings pad once. "ENTER TIME" flashes in the display
2. Enter the time using the numeric keys.
3. Press START.

This is a 12 hour clock. If you attempt to enter an incorrect clock time, the appliance will beep three times. Touch the STOP pad to clear the display and start again.

Audible Signal Elimination

You can change the volume of the microwave's audible signals.

1. Press the Settings pad twice.
2. "VOLUME" shows in the display. "LOW", "MED", and "HIGH" will show in a cycle.
3. Press START when the desired volume is shown in the display.

Pounds / Kilograms

The microwave can be set to use pounds or kilograms for measuring the weight of food.

1. Press the Settings pad 3 times. "Lb / KG" shows in the display.
2. Press START to change the setting. "KG" or "LB" will briefly display to show the new setting.

CARE AND CLEANING

Remove spills and any heavy soiling as soon as possible. Regular cleaning will reduce the difficulty of major cleaning later.

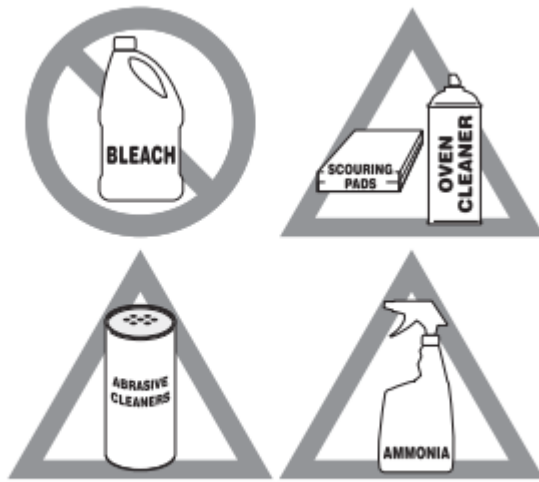

Figure 4: Use cleaners with caution

| Surface or Area | Cleaning Recommendation |
|--|--|
| Aluminum and vinyl | Using a soft cloth, clean with mild dish detergent and water. Rinse with clean water, dry and polish with a soft, clean cloth. |
| Painted and plastic controls Painted body parts Painted decorative trims | Using a soft cloth, clean with mild dish detergent and water or a 50/50 solution of white vinegar and water. Rinse with clean water, dry and polish with a soft, clean cloth. Glass cleaners may be used, but do not apply directly to surface; spray on a cloth and wipe. |
| Control panel | Using a soft cloth, clean with mild dish detergent and water or a 50/50 solution of white vinegar and water. Do not spray liquids directly on the oven control panel. Do not use large amounts of water on the control panel - excess water on the control panel area may cause damage to the appliance. Do not use other liquid cleaners, scouring pads, or paper towels - they will damage the finish. |
| Stainless Steel | Using a soft cloth, clean with mild dish detergent and water or a 50/50 solution of white vinegar and water. Rinse with clean water, dry with a soft clean cloth. Do not use cleaners containing abrasives, chlorides, chlorine, or ammonia. |
| Smudge Proof™ Stainless Steel Black Stainless Steel | Using a soft cloth, clean with mild dish detergent and water or a 50/50 solution of white vinegar and water. Rinse with clean water, dry with a soft clean cloth. Do not use appliance cleaner, stainless steel cleaner, or cleaner containing abrasives, chlorides, chlorine, or ammonia. These cleaners may damage the finish. |
| Porcelain-enameled broiler pan and insert Porcelain door liner Porcelain body parts | Rinse with clean water and a damp cloth. Scrub gently with a soapy, non-abrasive scouring pad to remove most spots. Rinse with a 50/50 solution of clean water and ammonia. If necessary, cover difficult spots with an ammonia-soaked pad for 30 to 40 minutes. Rinse and wipe dry with a clean cloth. Remove all cleaners before heating could damage the porcelain. Do not allow food spills with a high sugar or acid content (milk, tomatoes, sauerkraut, fruit juices or pie filling) to remain on these surfaces. These spills may cause a dull spot even after cleaning. |
| Self-cleaning oven interior | Before setting a self-clean cycle, clean soils from the oven frame, area around the oven door gasket, and the small area at the front center of the oven body. See "Self-Clean" on page 30. |

| | |
|-------------------------|--|
| <p>Oven door</p> | <p>Use mild dish detergent and water or a 50/50 solution of vinegar and water on the top, sides, and front of the oven door. Rinse well. Glass cleaner may be used on the outside glass of the door. Ceramic smoothtop cleaner or polish may be used on the interior door glass. Do not immerse the door in water. Do not spray oven cleaners or cleaners to enter the door vents. Do not use oven cleaners, cleaning solutions, or any harsh abrasive cleaning materials on the outside of the oven door.</p> <p>Do not clean the oven door gasket. The oven door gasket is made of a special material which is essential for a good seal. Do not rub, damage, or remove this material.</p> |
|-------------------------|--|

General Cleaning

Refer to the table at the beginning of this chapter for more information about cleaning specific parts of the oven.

CAUTION

Before manually cleaning any part of the oven, be sure all controls are turned off and the oven is cool. The oven may be hot and can cause burns.

Remove all racks and accessories from the oven before cleaning.

Ammonia must be rinsed before operating the oven. Provide adequate ventilation.

Follow these cleaning precautions:

- Allow the oven to cool before cleaning.
- Wear rubber gloves when cleaning the appliance manually.
- Remove soils using hot, soapy water. Do not allow food spills with a high sugar or acid content (such as milk, tomatoes, sauerkraut, fruit juices or pie filling) to remain on the surface as they may cause a dull spot even after cleaning. Remove spillovers and heavy soiling as soon as possible. Regular cleaning will reduce the effort required for major cleaning later.
- To maintain optimal rack performance, re-apply a thin layer of vegetable oil to the sides of the rack after every self-clean cycle or when the rack becomes difficult to slide.

Broiler Pan Cleaning Tips

To prevent grease from baking on, remove the broiler pan from the oven as soon as cooking is completed. Use oven mitts because the broiler pan is extremely hot. Pour off grease. Soak the pan in hot, soapy water.

Clean the broiler pan as soon as possible after each use. If necessary, use soap-filled steel wool pads. Heavy scouring may scratch the grid.

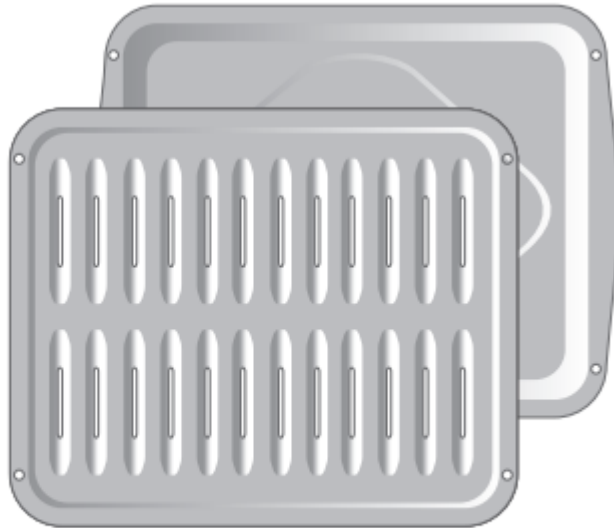

Figure 5: Broiler pan with insert

Aluminum Foil, Aluminum Utensils, and Oven Liners

WARNING

Never cover any slots, holes, or passages in the oven bottom or cover an entire oven rack with materials such as aluminum foil. Doing so blocks air flow through the oven and may cause carbon monoxide poisoning. Aluminum foil linings may trap heat, causing a fire hazard.

- Protective liners—Do not use aluminum foil to line the oven bottom. The high heat of the oven can melt these materials to the oven cavity and ruin the oven. These types of materials can also reduce the effectiveness of the air circulation in the oven and produce poor baking results. Only use aluminum foil as recommended in this manual. Improper installation of these liners may result in risk of electric shock or fire
- Aluminum utensils - The melting point of aluminum is much lower than that of other metals. Care must be taken when aluminum pots or pans are used.
- Oven racks - Do not use aluminum foil to cover the oven racks. Using a liner in the oven restricts the heat and air flow needed to obtain the best possible cooking results for any oven.

Replacing the Oven Light

CAUTION Be sure the oven is unplugged and all parts are cool before replacing the oven light

The interior oven light is located at the rear of the oven cavity and is covered by a glass shield. The glass shield must be in place whenever the oven is in use (Figure 6).

To replace the oven interior light bulb:

1. Turn electrical power off at the main source or unplug the appliance.

2. Remove interior oven light shield by turning a quarter turn counter-clockwise.
3. Replace bulb with a new T-4 type Halogen 25 watt appliance bulb.

NOTE

Wear a cotton glove or use a paper towel when installing a new bulb. Do not touch the new bulb with your fingers when replacing. This will shorten the life of the bulb.

4. Replace glass oven light shield by rotating clockwise.
5. Turn power back on again at the main source (or plug the appliance back in).
6. Be sure to reset the time of day on the clock

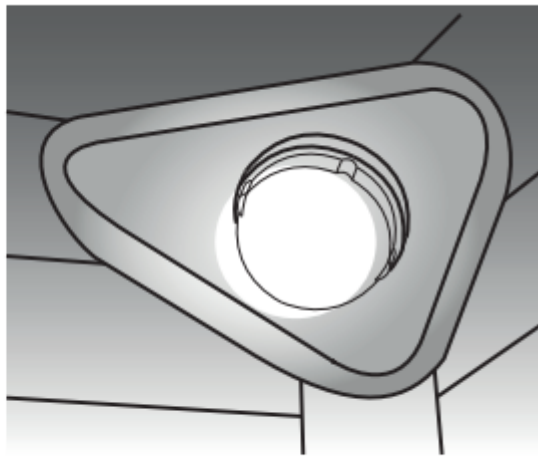

Figure 6: Wall oven Halogen light

Caring for Your Glide Racks

Caution: Handle oven racks only when they are cool. After cooking or after the fresh-clean cycle, racks will be very hot and can cause burns.

Important Notes:

- Remove all oven racks, including ladder racks, before starting a clean cycle.
- Do not use cooking oil, cooking spray, or other oil-based lubrication products on the glide rack extension tracks. Use only the graphite lubrication in this area. To order graphite lubrication, contact your installer, servicer or dealer.
- It is important that the parts of the rack that contact the oven sides always have a light coating of vegetable oil. Apply a thin layer of vegetable oil to the sides of the rack after every fresh-clean cycle and when the rack becomes difficult to reposition in the oven.

To lubricate the glide rack:

1. Remove the rack from the oven and place the rack on a large flat surface covered with newspaper or scrap cloth. Fully extend the rack.

2. Wipe away debris and crumbs from the glide track using a cloth or sponge.

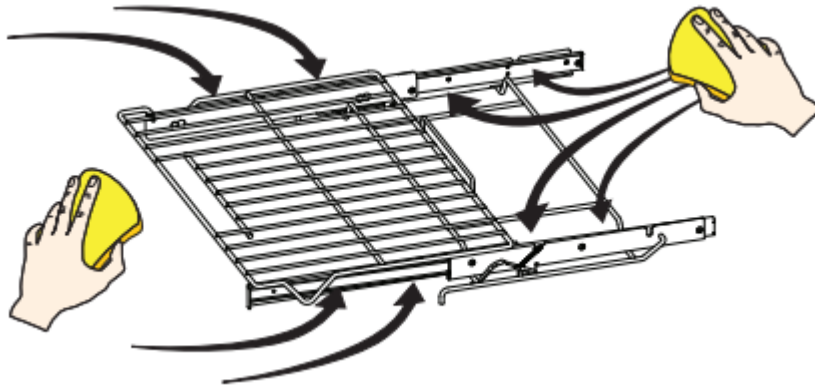

3. Shake graphite lubrication very well before applying. Apply to loading guides, and rotation pin. Repeat on both sides of the glide rack.

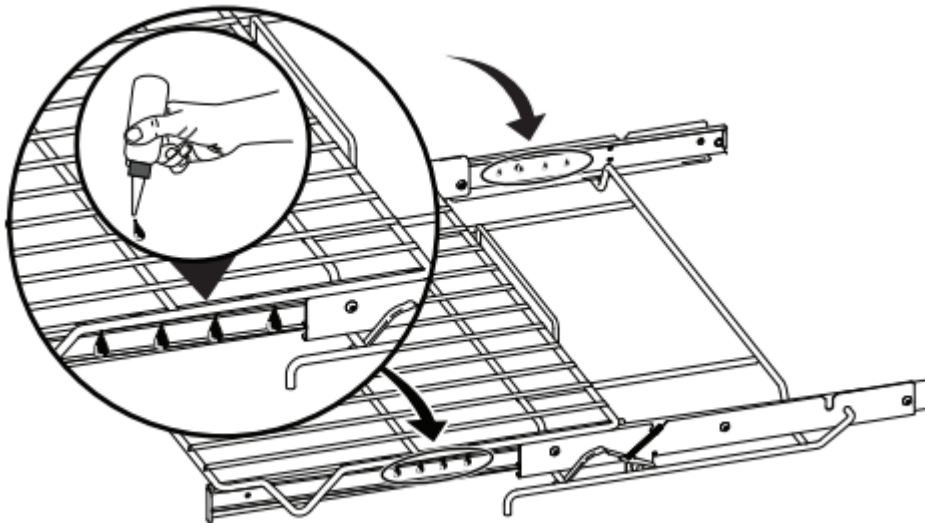

4. Extend and return the glide rack several times along the tracks to distribute the lubrication.

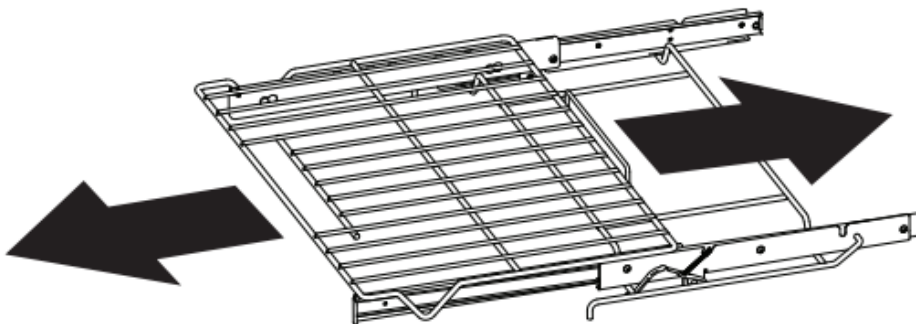

5. Turn the rack upside down and apply graphite lubrication to the insides of the loading guides.

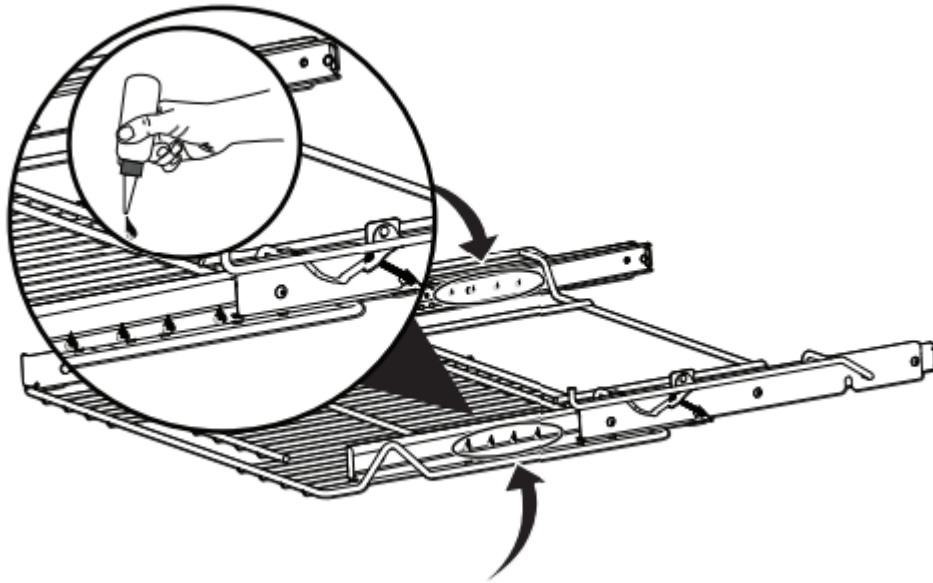

6. Extend and return the glide rack several times along the tracks to distribute the lubrication.

7. Apply a thin layer of cooking oil to the bottom of the “V” and the glide channels. Keeping the frame sides lightly lubricated allows the entire rack to slide easily when changing rack positions.

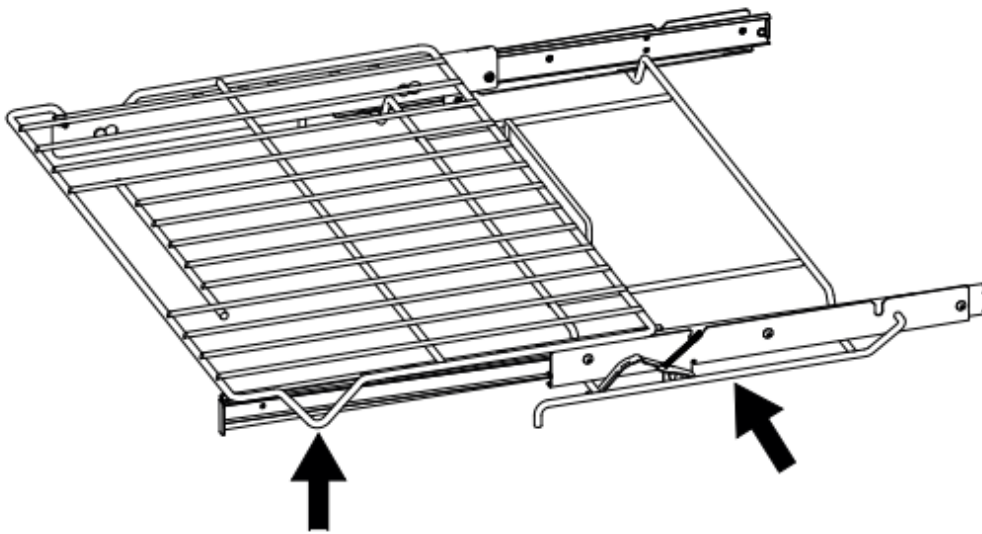

8. Replace rack in oven right-side up.

Removing and Replacing the Oven Door

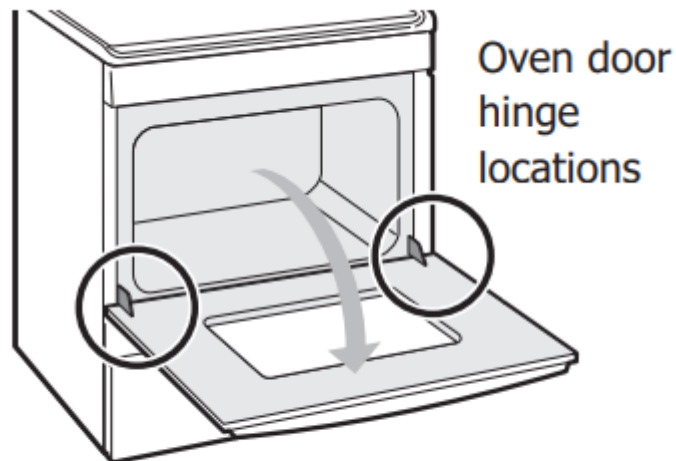

Figure 7: Door hinge location

To remove the oven door:

1. Open oven door completely, horizontal with floor.
2. Pull up the lock located on each hinge support toward front of the oven until the lock stops. You may have to apply a little upward pressure on the lock to pull it up (Figure 8 and Figure 9).

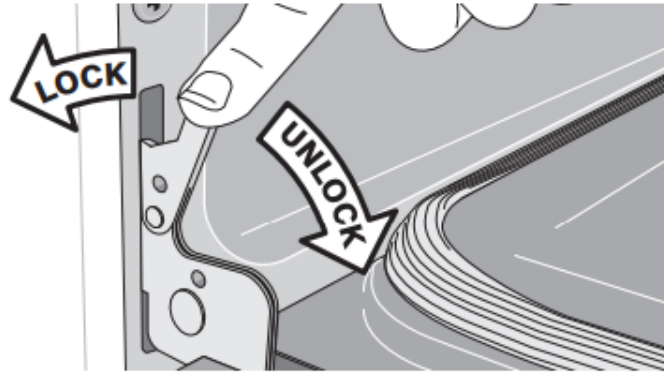

Figure 8: Door hinge locked

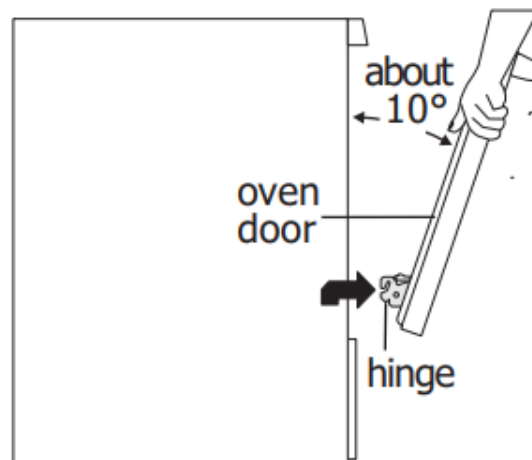

Figure 9: Unlocking door hinge

3. Grasp the door by the sides, and close the door until the door frame makes contact with the unlocked hinges.
4. Pull the bottom of the door toward you while rotating the top of the door toward the appliance to completely disengage the hinge levers (Figure 10).

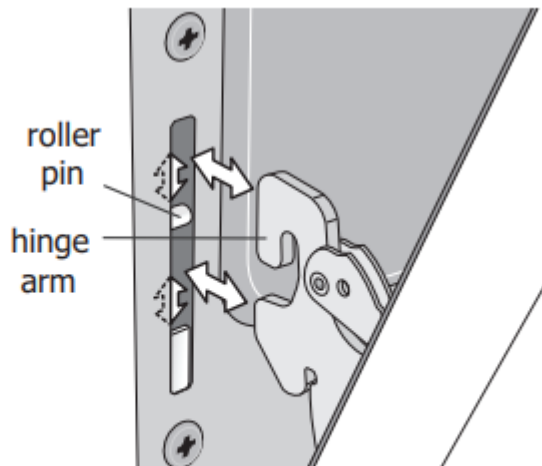

Figure 10: Remove door position

To Replace Oven Door:

1. Firmly grasp both sides of oven door along the door sides. Do not use the oven door handle (Figure 10).

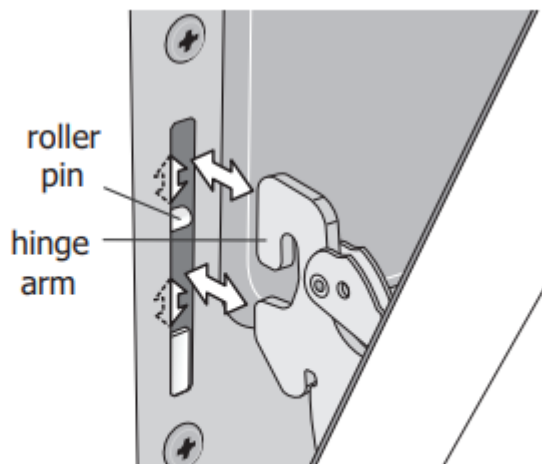

Figure 10: Remove door position

2. Hold the oven door at the same angle as the removal position. Carefully insert the hinge levers into the oven frame until you feel the hinge levers are seated into the hinge notches. The hinge arms must be fully seated into the hinge notches before the oven door can be fully opened. (Figure 10).
3. Fully open the oven door, horizontal with floor (Figure 7).

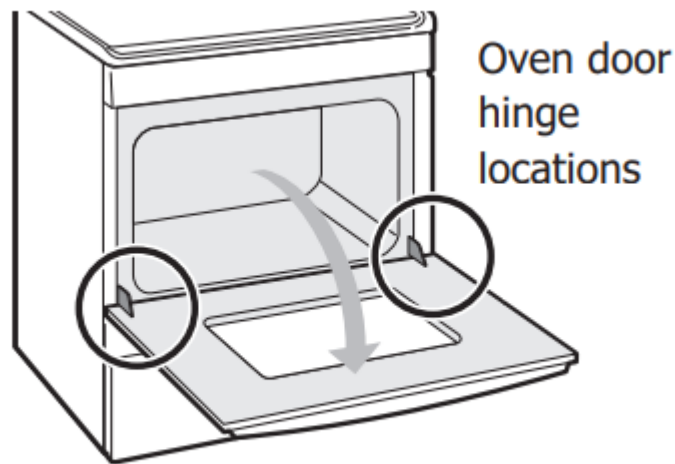

Figure 7: Door hinge location

4. Push the door hinge locks up toward and into the oven frame on both left and right oven door hinges to the locked position (Figure 8)

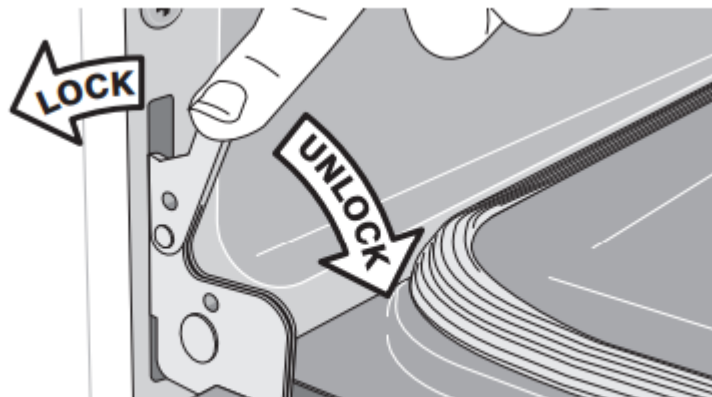

Figure 8: Door hinge locked

5. Close the oven door.

Cleaning the Microwave

For best performance and for safety reasons, keep the oven clean inside and outside. Take special care to keep the inner door panel and oven frame free of food and grease build-up.

Never use rough scouring powder or pads on the microwave. Wipe the microwave oven inside and out with a soft cloth and warm (not hot) mild detergent solution. Then rinse and wipe completely dry.

Wipe spatters immediately with a wet paper towel, especially after cooking greasy foods like chicken or bacon.





Follow these instructions to clean and care for your microwave oven:

- Keep the inside (cavity) of the oven clean. Food particles and spilled liquids can stick to the oven walls, causing the oven to work less efficiently.
- Wipe up spills immediately. Use a damp, clean cloth and mild detergent. DO NOT use harsh detergents or abrasive cleaners.
- To help loosen baked-on food particles or liquids, heat 2 cups of water (add the juice of 1 lemon if you desire to keep the oven fresh smelling) in a 4 cup measuring glass at High power for 5 minutes or until boiling. Let stand in oven cavity for 1 or 2 minutes.
- Remove the glass turntable tray from the oven when cleaning the oven cavity or tray. To prevent the glass turntable from breaking, handle with care and do not put it in water immediately after cooking. Wash the turntable tray with mild detergent.
- Clean the outside surface of the microwave with mild detergent and a clean damp cloth. Dry with a clean soft cloth. To prevent damage to the operating parts of the oven, do not let water seep into any vents or openings.
- Wash the oven door window with very mild soap and water. Be sure to use a soft clean cloth to avoid scratching.
- If steam accumulates inside or outside the oven door, wipe with a soft cloth. Steam can accumulate when operating the oven in high humidity and in no way indicates microwave leakage.
- Never operate the oven without food in the oven cavity; this can damage the magnetron tube or glass tray.

BEFORE YOU CALL

Solutions to Common Baking Problems

For best cooking results, preheat the oven before baking cookies, breads, cakes, pies, pastries, etc. There is no need to preheat the oven for roasting meat or baking casseroles. The cooking times and temperatures needed to bake a product may vary slightly from your previously owned appliance.

| Baking Problems and Solutions | | |
|--|---|--|
| Baking Problems | Causes | Corrections |
| <p>Cookies and biscuits burn on the bottom.</p>  | <p>Cookies and biscuits put into oven before the preheating time is completed.</p> <p>Oven rack is overcrowded.</p> <p>Dark pans absorbs heat too fast.</p> | <p>Allow oven to preheat to desired temperature before placing food in oven.</p> <p>Choose pan sizes that will permit 2" to 4" of air space (5.1 cm o 10.2 cm) on all sides when placed in the oven.</p> <p>Use a medium weight baking sheet.</p> |
| <p>Cakes too dark on top or bottom</p>  | <p>Cakes put in oven before preheating time is completed.</p> <p>Rack position too high or too low.</p> <p>Oven too hot.</p> | <p>Allow oven to preheat to the selected temperature before placing food in the oven.</p> <p>Use proper rack position for baking needs.</p> <p>Set oven temperature 25°F (13°C) lower than recommended.</p> |
| <p>Cakes not done in center</p>  | <p>Oven too hot.</p> <p>Incorrect pan size.</p> <p>Pan not centered in oven.</p> <p>Glass cookware slow heat conductor.</p> | <p>Set oven temperature 25°F (13°C) lower than recommended. Use pan size suggested in recipe.</p> <p>Use proper rack position and place pan so there is 5.1 cm to 10.2 cm (2" to 4") of space on all sides of pan.</p> <p>Reduce temperature and increase cook time or use shiny bakeware.</p> |
| <p>Cakes not level.</p>  | <p>Oven not level.</p> <p>Pan too close to oven wall or rack overcrowded.</p> | <p>Place a marked glass measuring cup filled with water on the center of the oven rack. If the water level is</p> |

| | | |
|---|--|--|
| | Pan warped. | <p>uneven, refer to the installation instructions for leveling the oven.</p> <p>Be sure to allow 5.1 cm to 10.2 cm (2" to 4") of clearance on all sides of each pan in the oven.</p> <p>Do not use pans that are dented or warped.</p> |
| <p>Foods not done when cooking time is over.</p>  | <p>Oven too cool.</p> <p>Oven overcrowded.</p> <p>Oven door opened too frequently.</p> | <p>Set oven temperature 25 F (13 C) higher than suggested and bake for the recommended time.</p> <p>Be sure to remove all pans from the oven except the ones to be used for baking.</p> <p>Open oven door only after shortest recommended baking time.</p> <p>Make sure to allow 2" to 4" of clearance between all pans and racks, allowing for even air flow.</p> |

Solutions to Common Problems:

Before you call for service, review the following list. It may save you time and expense. Possible solutions are provided with the problem listed.

| Problem | Cause / Solution |
|--|---|
| <p>Oven control panel beeps and displays error codes</p> | <ul style="list-style-type: none"> • Oven control has detected a fault or error condition. When the error code E or F will show in the display. • Turn both oven selectors to the OFF position; Activate a Bake or Broil function using both the oven mode and temperature selectors. • If the F or E code error repeats, turn off power to appliance for 5-10 minutes and then repower appliance. Set clock with correct time. • Try Bake or Broil function again. If a fault code appear again, turn both oven selectors to the OFF position to clear the error code and contact your servicer. |
| <p>Poor baking results.</p> | <ul style="list-style-type: none"> • Many factors effect baking results. • Use proper oven rack position. • Center food in the oven and space pans to allow air to circulate. • Preheat oven to the set temperature before placing food in oven. • Try adjusting the recipe's recommended temperature or bake time. See "Adjusting Oven Temperatures" on page 36 if you feel the oven is too hot or cold |
| <p>Quick Preheat performs poorly</p> | <ul style="list-style-type: none"> • Quick Preheat not used correctly. This cooking function is intended for convenience, precooked, and other specific foods. See "Quick Preheat" on page 20 and follow tips for best using this feature. |
| <p>Appliance is not level</p> | <ul style="list-style-type: none"> • Poor installation. Place oven rack in center of oven. Place a level on top of oven rack to check if oven has been properly installed. • Kitchen cabinet alignment may make oven appear not level. Make sure cabinets are square and have sufficient room for appliance. • If cabinets are not square or are built in too tightly, contact kitchen installer to make appliance accessible |
| <p>Cannot move appliance easily Appliance must be accessible for service</p> | <ul style="list-style-type: none"> • Cabinets not square or are built in too tightly. • Contact builder or installer to make appliance accessible. |



| | |
|--|---|
| <p>Appliance does not operate</p> | <ul style="list-style-type: none"> • Electrical power outage. Check house lights to be sure. • Call your local electric company for service outage information. • Service wiring is incomplete. Call 1-800-944-9044 for assistance. |
| <p>Flames inside oven or smoking from oven vent</p> | <ul style="list-style-type: none"> • Excessive spills in oven. Grease or food spilled onto oven broiler cavity. Wipe up excessive spills before starting oven. • If flames or excessive smoke are present when broiling, See “Broil” on page 24 |
| <p>Oven does not operate.</p> | <ul style="list-style-type: none"> • The time of day is not set. The oven clock must first be set to operate the oven. See “Setting the Clock” on page 18. • Be sure oven controls are set properly. See “Oven Control Panel” beginning on page 17 and review instructions for the desired function in this manual. |
| <p>Oven smokes excessively when broiling.</p> | <ul style="list-style-type: none"> • Incorrect setting. See “Setting Broil” on page 24. • Meat too close to the broil element. Reposition rack to provide clearance between the meat and broil element. Remove excess meat. Cut remaining fatty edges to prevent curling, but do not over-lean. • Grease build up on oven surfaces. Regular cleaning is necessary when broiling frequently. Grease or food splatters will cause excessive smoke. |
| <p>Oven racks discolored or do not slide easily.</p> | <ul style="list-style-type: none"> • Clean by using a mild abrasive cleaner following manufacturer’s instructions. Rinse with clean water, dry, and replace in oven. |
| <p>Oven light does not work.</p> | <ul style="list-style-type: none"> • Be sure the oven light is secure in the socket. See “Replace Light” on page 52. |
| <p>Fan noise occurring after the oven is turned off</p> | <ul style="list-style-type: none"> • Some models are equipped with a cooling fan that runs during the cooking process to cool internal electronic components. In some models, this fan to continue to run for an extended period of time, even after the oven has been turned off. |



Microwave Oven

Before you call a repair person for your microwave, check the list below for possible easy solutions to some common problems.

| Problem | Cause / Solution |
|--|---|
| Neither the microwave's display or microwave oven operates | <p>Check the household circuit breaker.</p> <p>Shut off power to the circuit, wait 10 seconds, then restore power to the microwave again.</p> |
| The microwave's display works, but the microwave oven will not operate | <p>Make sure the microwave door is closed securely and completely.</p> <p>Check to see if packing material or other materials are stuck to the door.</p> <p>Check for damage to the microwave door. Contact service if damaged.</p> <p>Press the STOP pad twice and attempt to re-enter cooking instructions.</p> |
| The microwave oven stops before the cook time has elapsed | <p>Check the household circuit breaker.</p> <p>If there has been a power interruption, shut off power to the circuit, wait 10 seconds, then restore power to the microwave. If there was a power interruption, the time indicator in the display will show 00:00.</p> <p>Reset the clock and any cooking instructions.</p> <p>Press the STOP pad twice and attempt to re-enter cooking instructions.</p> |
| You see sparks or arcing | <p>Remove any metallic utensils, cookware or metal ties from the microwave.</p> |
| The turntable makes noises or sticks | <p>Clean the turntable, roller ring, and oven cavity bottom.</p> <p>Make sure the turntable and roller ring are positioned correctly.</p> |
| Using your microwave causes TV or radio interference | <p>This is similar to the interference caused by other small appliances, such as hair dryers. Move your microwave further away from other appliances.</p> |

Warning

This content is compiled from multiple sources and is provided for reference purposes only. It may not be complete or fully applicable to all situations. If you are unable to resolve your issue, please contact the product manufacturer or an authorized service provider for official support.

